



**High
Luminosity
LHC**

Discussion on Q4 aperture

G. Arduini, R. De Maria, M. Fitterer, M. Giovannozzi
Thanks to, C. Garion, S. Fartoukh, P. Fessia,
C. Magnier, H. Prin, E. Todesco, B. Vasquez De Prada

Aperture margins

1. Layout and optics define nominal orbit and beam sizes.
2. Geometry of the vacuum system (e.g. beam screens inner dimensions with tolerances).
3. Operational tolerances on beam size are added to the actual beam size.
4. Alignment and fiducialization tolerances are subtracted from available aperture.
5. The difference in units of beam sigma is calculated and compared with the aperture protected by the collimation systems

Aperture triplet region

Octagonal beam screens for triplets/D1 with tungsten shielding have been designed.

Expected straightness: 0.5 mm

Shape tolerance: ± 1 mm (C. Garion 12/06/2015), to be confirmed by the prototype.

The possibility of reducing the tungsten layer thanks to alternating crossing planes (**F. Cerutti, S. Fartoukh**) should be checked.

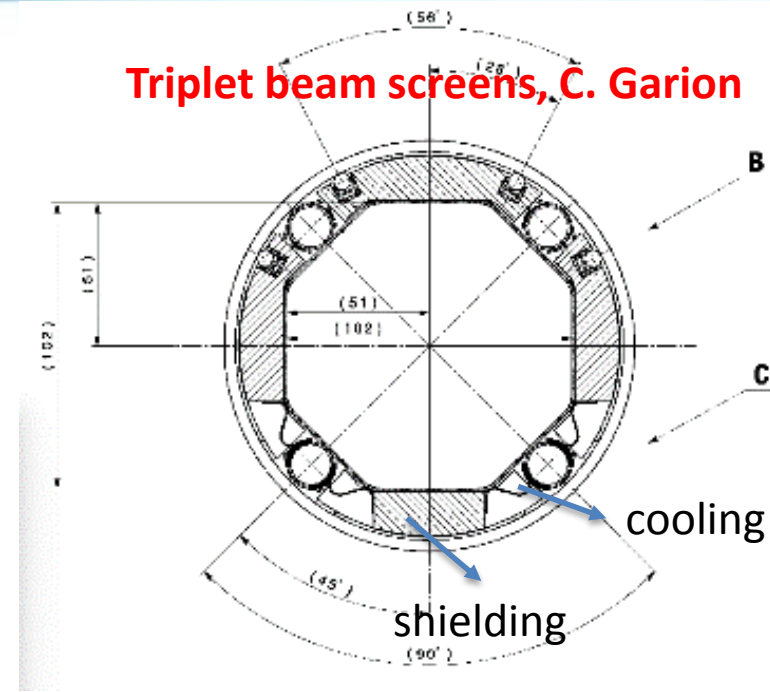

Element	H or V gap [mm]	45° gap [mm]
Q1	102-1.5	102-1.5
Q2-Q3-CP	122-1.5	114-1.5
D1	122-1.5	114-1.5

Aperture D2-Q4-Q5

New D2-Q4 octagonal beam screens have been designed, **no tolerances given, yet.**

Q5 beam screens (RectEllipse) oriented for collision optics aperture optimizations.

Same triplet tolerances removed from the mechanical dimensions.

Element	H or V gap [mm]	45° gap [mm]
MBRD	87.0-1.5	78.0-1.5
MQYY	78.5-1.5	63.8-1.5
Q5	57.8, 48.0	

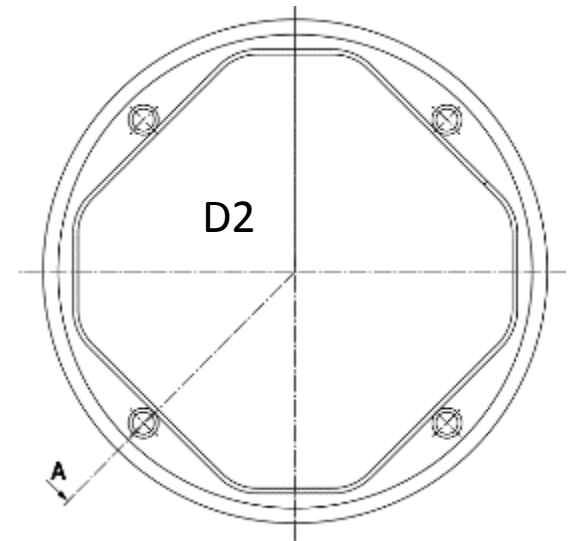

C. Garion, no tolerances included

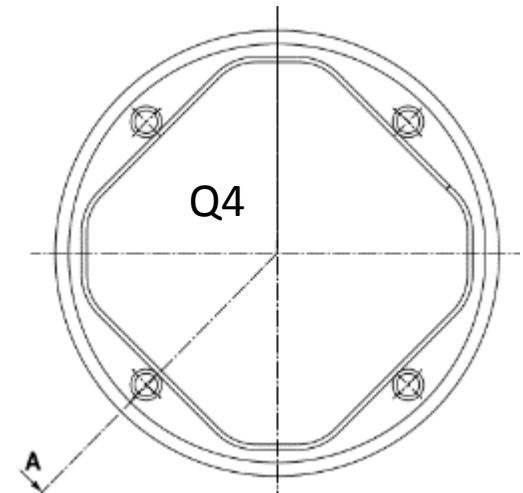

Beam tolerances and collimation protection

Beam tolerances have been re-defined by:

- Taking into account LHC Run I successful experience
- Adding safety margins based on possible unknowns.

For collimation:

- magnet protected by TCT: $\geq 12 \sigma$
- magnet not protect by TCT: $18 \sigma^{(2)}$ or possibly less, pending dedicated studies (R. Bruce) .

Beam Tolerance	LHC DR Inj./Coll.	HL-LHC Inj./Coll.
Emittance [μm] (normalization only)	3.75/3.75	3.5/3.5
β -beating [%]	20/20	10/20
Orbit error [mm]	4/3	4/2
Spurious Disp. [%]	27.3/27.3	14/10
$\Delta p/p$ [10^{-4}]	15/8.6	6/2
Target aperture [σ]	8.4/8.4	9⁽¹⁾/12 (18⁽²⁾)

R. Bruce et al., CERN-ACC-2014-0044

Minimum aperture not protected by TCT in collision and aperture targets at injection should be confirmed by WP5⁽²⁾ and WP14⁽¹⁾.

Aperture vs optics for baseline

	Round 15 cm	Round 20 cm	Flat 7.5 cm	Flat 10 cm
	[σ]	[σ]	[σ]	[σ]
TAXS	9.9	12.1	9.6	11.3
MQXFA.[AB]1	13.2	16	12.3	14.2
MQXFB.[AB]2	9.4	11.7	9.7	11.2
MQXFA.[AB]3	9.5	11.8	10	11.6
MBXF	10.7	13.1	10.6	12.3
TAXN	11.6	13.8	9.5	11.0
MBRD	13.1	15.3	11.1	12.8
MCBRD	16	18.7	13.7	15.4
MCBYY	15.4	17.9	13.4	15.5
MQYY	16.3	18.9	13.9	16.1
TCLMB.5	20.3	23.5	14.5	16.8
MCBY[HV].5	20.6	23.9	15	17.3
MQY.5	21.4	24.7	15.3	17.7
TCLMC.6	21.2	24.6	15	17.4
MCBC[HV].6	24.7	28.5	17.4	20.1
MQML.6	21.8	25.2	15.7	18.1

Aperture includes worst case scenarios for all knobs (IP crossing, separation, offset, crab cavity offset) assuming linear addition

Aperture in the triplets can be recovered by:

- reducing beam screen/cold bore tolerances, shielding thickness (see US-LARP presentation)
- reducing crossing angle (round optics) and separation (flat optics) if one assumes that β^* levelling is feasible

This allows:

- more aperture in the triplet at constant β^* or
- more performance if matching section keeps present margins.

Q4 options

Aperture includes worst case scenarios for all knobs:
IP crossing, separation, offset, crab cavity offset
(assuming linear addition).

	Coil aperture	Beam ¹ aperture	H,V ² full gaps	Round 15 cm	Round 20 cm	Flat 7.5 cm	Flat 10 cm
	[mm]		[mm]	[σ]	[σ]	[σ]	[σ]
MCBYY	90	Octagon	73.8,73.8	15.4	17.9	13.4	15.5
MQYY	90	Octagon	73.8,73.8	16.3	18.9	13.9	16.1
MCBYY	80	Octagon	63.8,63.8	11.6	13.5	10.1	11.7
MQYY	80	Octagon	63.8,63.8	12.3	14.2	10.5	12.1
MCBY	70	RectEllipse	57.8,48	11.8	13.7	8.4	9.8
MQY	70	RectEllipse	57.8,48	13	15.1	9.2	10.6

- **We exclude the option MQY for robust flat optics operations.**
- **MQYY at 80 mm is not sufficient to provide enough flexibility:**
 - Any improvement in triplet aperture would be useless if Q4 aperture is degraded.
 - If Q4 needs to be pushed towards D2 more aperture is needed (about 0.7 σ).
 - In case of operation at 6.5 TeV.
 - The use of a Rectellipse beam screen can help recovering aperture, but only in specific cases: freezing optics constraints or crossing plane.

Impact of energy deposition needs to be re-evaluated in case of reduction of coil aperture

Q4: MQY with 70 mm coils

Round

Flat

Left

Right

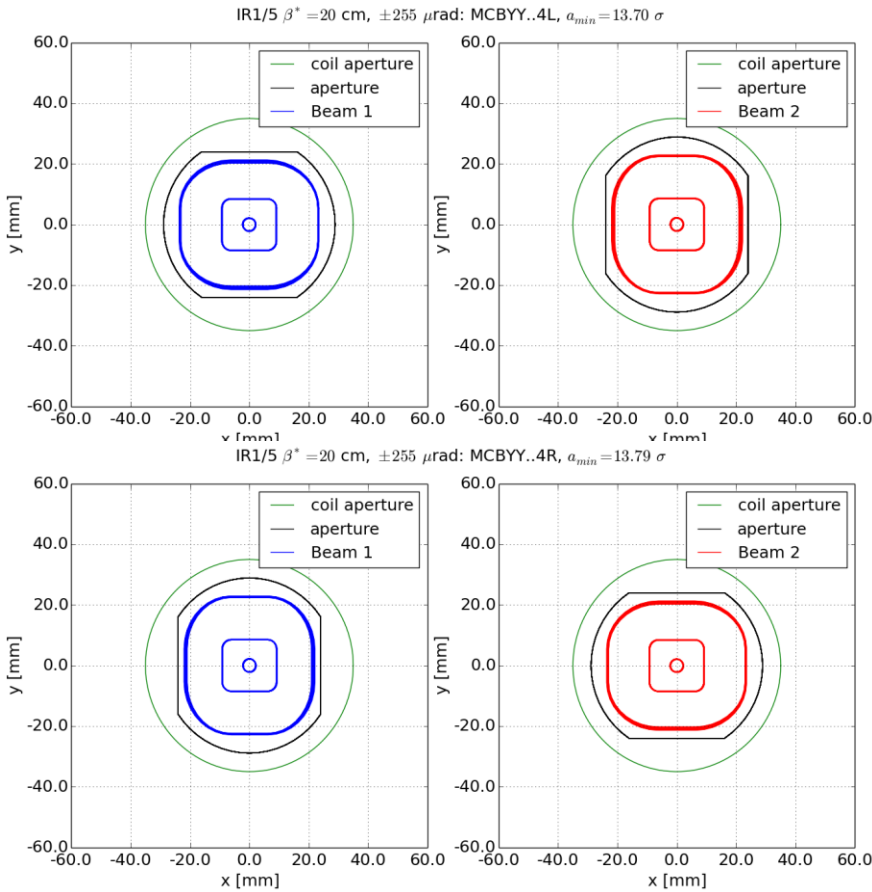

Q4 with MQY not ok.

Q4: MQYY with 80 mm coils

Round

Flat

Left

Right

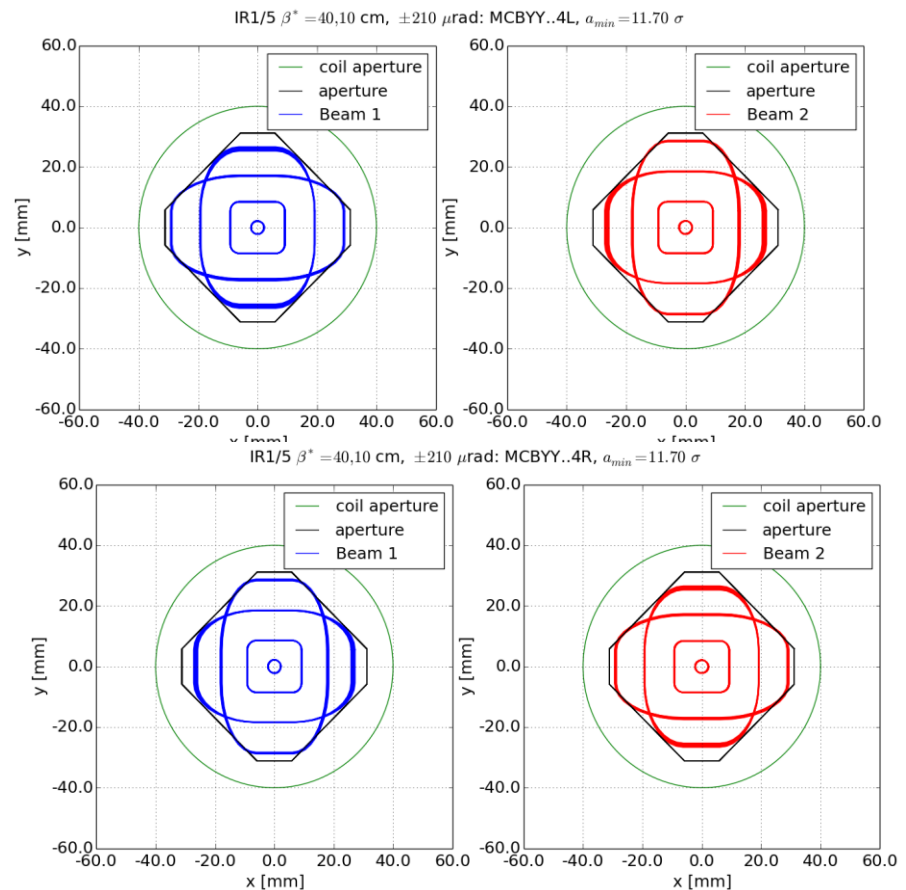
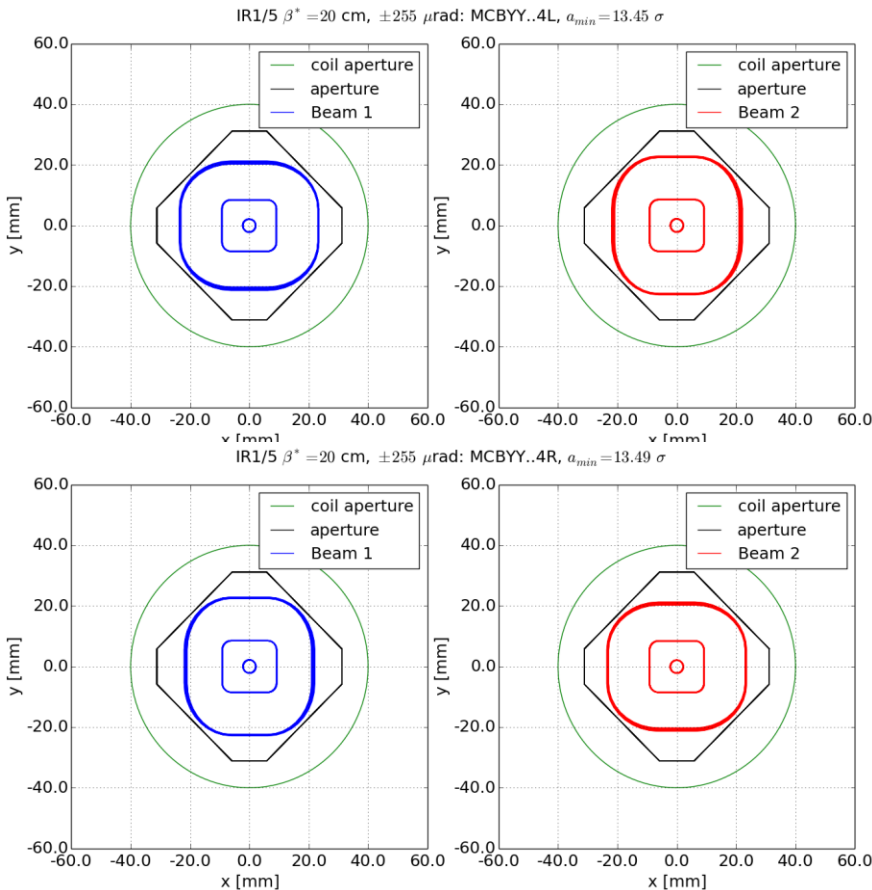

MQYY with 80mm coil not OK. RectEllipse option can help only for special cases.

Q4: MQYY with 90 mm coils

Round

Flat

Left

Right

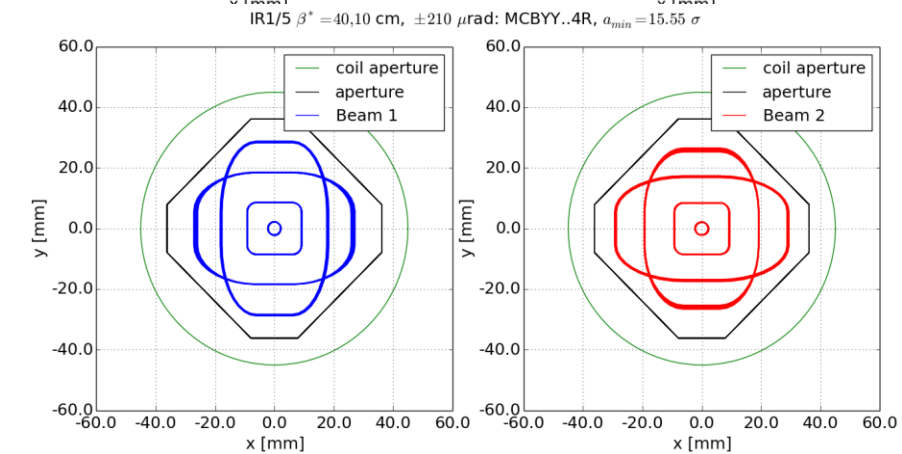
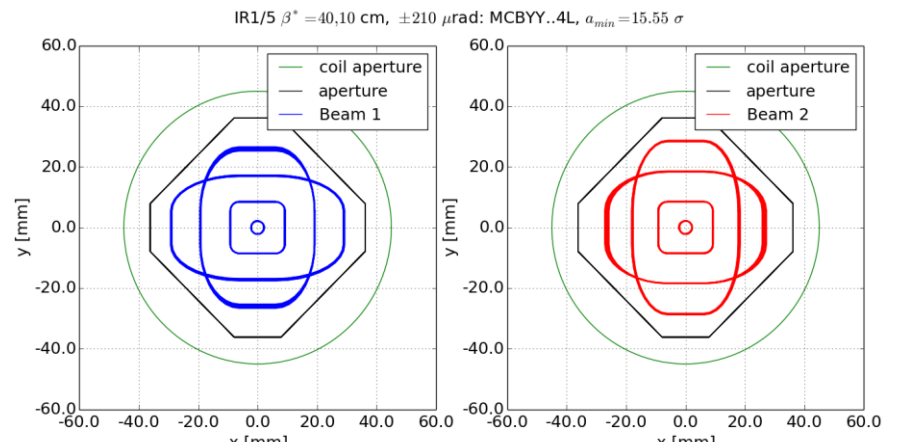
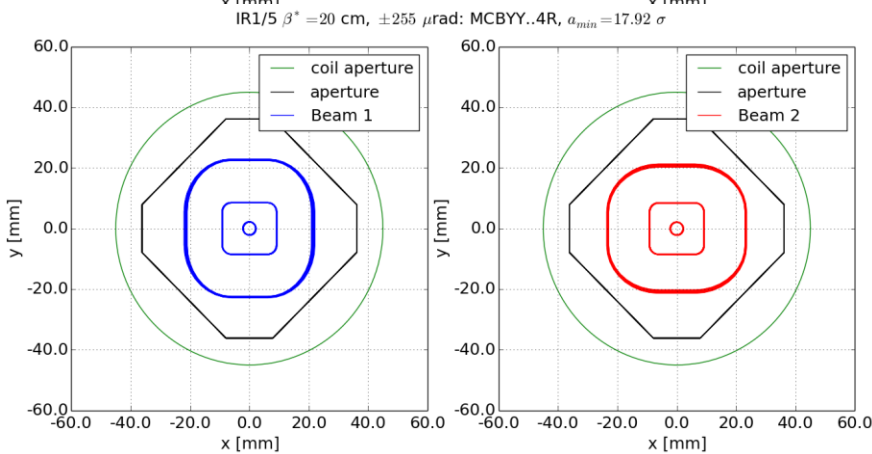
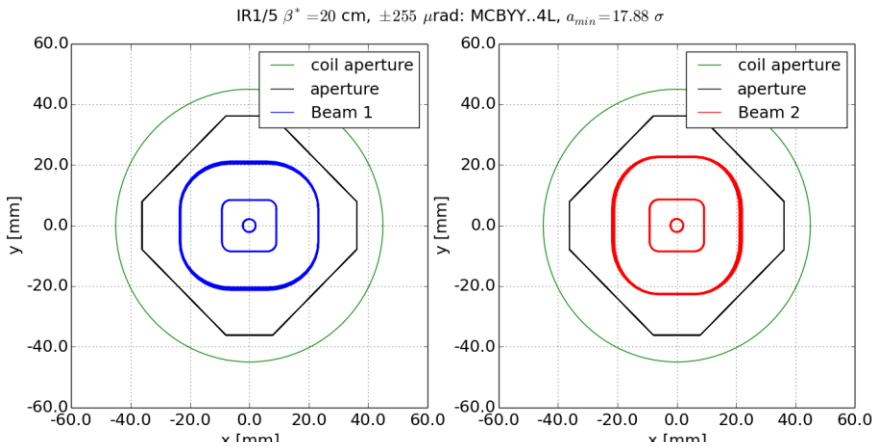

Q4 with MQYY: OK.

Conclusions

- Aperture margins have been reviewed from LHC DR based on Run I experience and applied to HL-LHC design.
- The most complete set of tolerances on beam parameters has been worked out.
- Some mechanical tolerances are still missing for a final aperture evaluation.
- Concerning Q4 aperture:
 - MQY is not compatible with target aperture for flat optics.
 - MQYY with lower-than-baseline aperture downgrades the overall performance and the energy deposition should be re-evaluated.

Spare slides

Survey tolerances

	Ground motion			Fiducialization		
	r [mm]	h [mm]	v [mm]	r [mm]	h [mm]	v [mm]
TAXS (*)	2.0	0	0	0	0.5	0.5
Triplets	0.6	0	0	0	1.0	1.0
BPMs	0	0	0	2.5	0	0
TAXN (*)	0.84	0.36	0	0	1.0	1.0
D1	0.6	0.36	0	0	1.0	1.0
D2/Q4/Q5	0.84	0.36	0	0	0.9	0.6

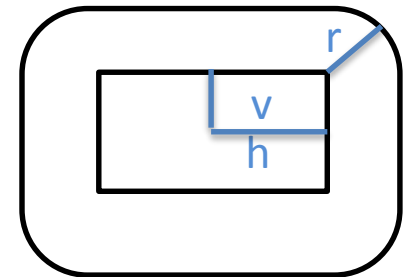

Values **by J. Jeanneret, LHC report 1007** as from nominal LHC
 To be validated by survey, WP3, WP8 (*) teams

Orbit correction knobs

- IP crossing, separation, offset (**x**: $\pm 295 \mu\text{rad}$, **s**: $\pm 0.75 \text{ mm}$, **o**: $\pm 2.0 \text{ mm}$)
- Beam based alignment of crab cavities:
 - **ccp**, **ccm** (shift): $\pm 0.5 \text{ mm}$
 - **ccs** (slope): $\pm 0.25 \text{ mm}$
- IT alignment and transfer function errors (**err**):
 - $\pm 0.5 \text{ mm}$ transverse,
 - $\pm 10 \text{ mm}$ longitudinal,
 - $\pm 2 \times 10^{-3}$ relative gradient error,
- D2 relative field error: $\pm 2 \times 10^{-3}$
- Orbit correction from the arc (to confirmed): **arc** 0.7 Tm ;
- **Lumi** scan knobs (single beam IP shift for $100 \mu\text{m}$)

Effect of the knobs

	Coil aperture	Beam ¹ aperture	H,V ² full gaps	Sep. knob	Crossing Knob	Crab shift knob	Crab slope knob	Offset knob
	[mm]		[mm]	[mm]	[mm]	[mm]	[mm]	[mm]
TAXS	54	Circle	54, 54	0.8	6.1	0.0	0.0	2.0
MQXFA.[AB]1	150	Octagon	102, 102	0.8	11.2	0.0	0.0	2.4
MQXFB.[AB]2	150	Octagon	122, 122	1.2	16.7	0.2	0.0	3.6
MQXFA.[AB]3	150	Octagon	122, 122	0.8	16.6	0.4	0.0	2.8
MBXF	150	Octagon	122, 122	0.5	15.5	0.5	0.0	2.4
TAXN	n/a	Circle	80, 80	0.2	5.5	0.9	0.0	3.0
MBRD	105	Octagon	87, 87	0.1	3.3	1.0	0.0	3.3
MCBRD	105	Octagon	87, 87	0.1	1.7	1.0	0.1	3.4
MCBYY	90	Octagon	73.8,73.8	0.0	0.1	1.0	0.5	4.0
MQYY	90	Octagon	73.8,73.8	0.0	0.0	1.0	0.5	3.9
TCLMB.5		RectEllipse	57.8, 48	0.0	0.0	0.4	0.2	3.7
MCBY[HV].5	70	RectEllipse	57.8, 48	0.0	0.0	0.0	0.0	3.6
MQY.5	70	RectEllipse	57.8, 48	0.0	0.0	0.2	0.1	3.5
TCLMC.6	56	RectEllipse	45.1,35.3	0.0	0.0	0.0	0.0	2.3
MCBC[HV].6	56	RectEllipse	45.1,35.3	0.0	0.0	0.0	0.0	2.1
MQML.6	56	RectEllipse	45.1,35.3	0.0	0.0	0.0	0.0	2.1

¹Either Beam screen or beam pipe;

² Rectellipse types are exchanges the H,V orientation depending on the polarity

Q1

Round

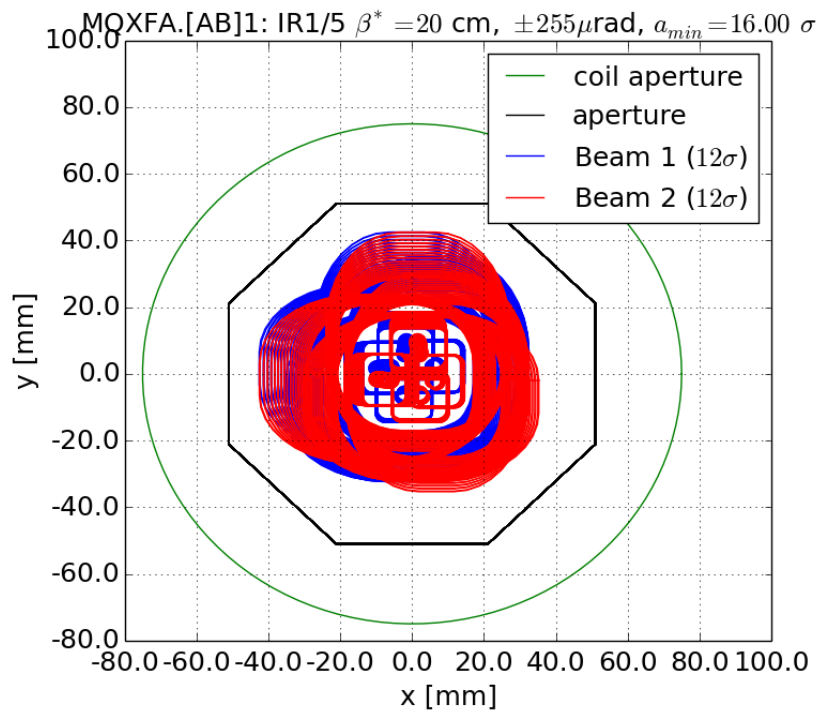

Flat

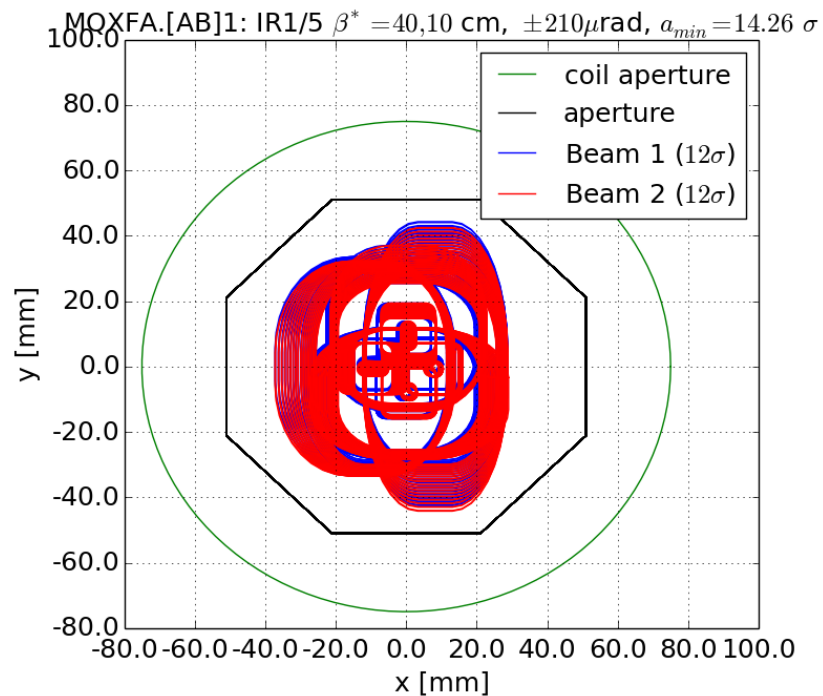

Q1 OK

Q2

Round

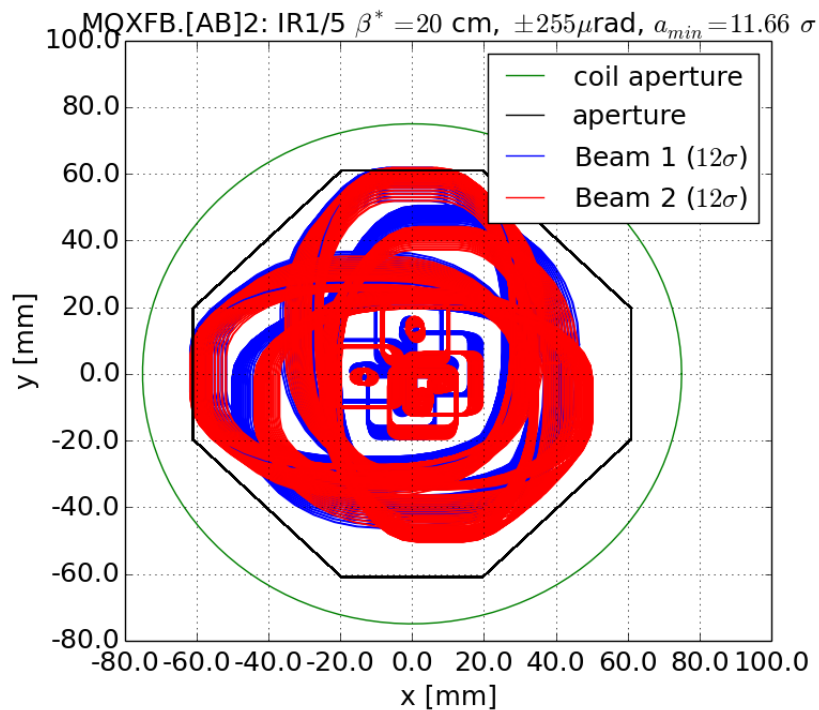

Flat

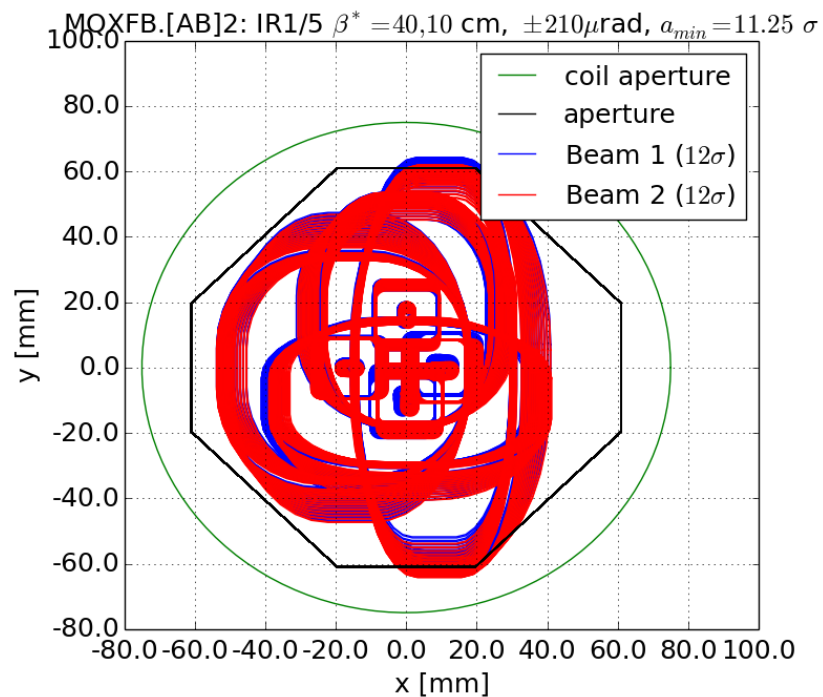

Q2 OK