





FCC-ee injector complex including Booster

Yannis Papaphilippou, CERN

Thanks to:

M.Aiba (PSI), Ö.Etiskan (Ankara Un.), K.Oide (KEK),
L.Rinolfi (ESI-JUAS), D.Shwartz (BINP), F.Zimmermann
(CERN)



Outline



- FCC injector complex
- Injector parameters for past and future projects
- Tentative parameters for FCCee injector
- Design of Booster Ring
- Summary

FCCee injector complex



- Injector complex is comprised by:
 - e^+ / e^- LINAC (up to ~ 10 GeV)
 - Pre-Booster Damping Ring - PBDR (from ~ 10 to ~ 20 GeV)
 - Booster ring (from ~ 20 to full FCCee energy)
 - Proposal for extra ring with wigglers for rapid radiative polarization (@ $\sim 1-2$ GeV)

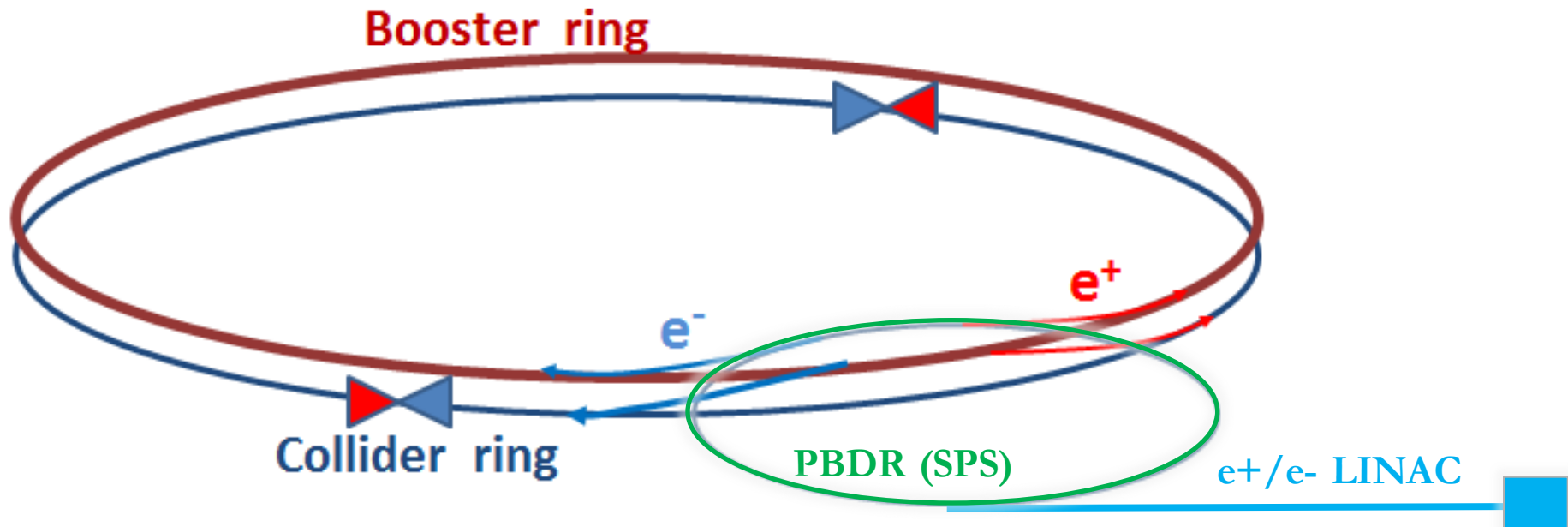

Target injector parameters



Parameters (2016)	Z		WW	ZH	tt	LEP2
E [GeV]	45.6		80	120	175	104
I [mA]	1450		5260	780	81	1
No. bunches	30180	91500	5260	780	81	4
Bunch population [10^{11}]	1.0	0.33	0.6	0.8	1.7	4.2
Lifetime [min]	94	185	90	67	57	434
Time between injections [sec]	114	224	109	81	69	263

- Short lifetimes from radiative Bhabha scattering and from BS, require continuous top-up injection.
- For defining injector cycle and flux, assumed **2%** of **current decay** between top-ups
- The top energy FCC-ee defines the minimum time between injections/species (**69 sec** for this parameter set)
- Considering **50% duty factor** (Interleaved e^+/e^- injection), and minimum lifetime of **~ 10 min**, injections should be made every **12 sec** at a rate of **~ 0.1 Hz**

Target injector parameters



Parameters (2016)	Z		WW	ZH	tt	LEP2
E [GeV]	45.6		80	120	175	104
I [mA]	1450		5260	780	81	1
No. bunches	30180	91500	5260	780	81	4
Bunch population [10^{11}]	1.0	0.33	0.6	0.8	1.7	4.2
Lifetime [min]	94	185	90	67	57	434
Time between injections [sec]	114	224	109	81	69	263
Injected top-up bunch population [10^{11}]	604.2		63.2	12.5	2.8	0.34
Required particle flux for top-up [10^{11} p/sec]	6.6	3.4	0.7	0.19	0.05	0.001
Required particle flux for full filling [10^{11} p/sec]	31.3		3.3	0.7	0.1	0.02
Booster injector ramp rate [GeV/sec]	5.2		12.2	20.4	31.6	

- For full collider filling, assumed **20 min** of filling time and **80 %** transfer efficiency along the injector chain
- Main flux challenge of **3.1×10^{12} p/sec** coming from the full filling of the FCCee-Z
- Maximum ramp rate of ~ 32 GeV/sec (10 sec cycle with linear ramp and short flat bottom and top of ~ 100 ms), lower than SPS ramp rate (~ 62 GeV/sec)

SuperKEKB injector



- Lifetime of 6 min necessitates top-up
- Injector should serve 4 rings
 - Repetition rate 50Hz
- Positron flux rate at 2.5×10^{12} p/s is **almost compatible** with FCC-ee
- **Collaboration** with KEK colleagues essential

K.Furukawa, FCCee week 2016

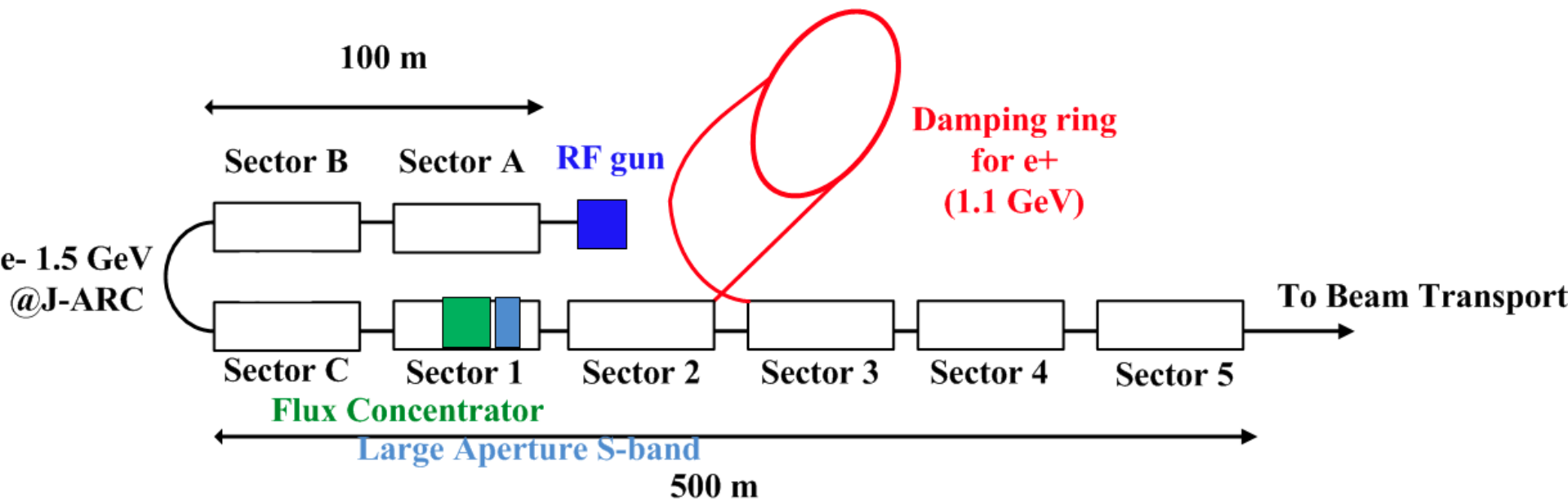
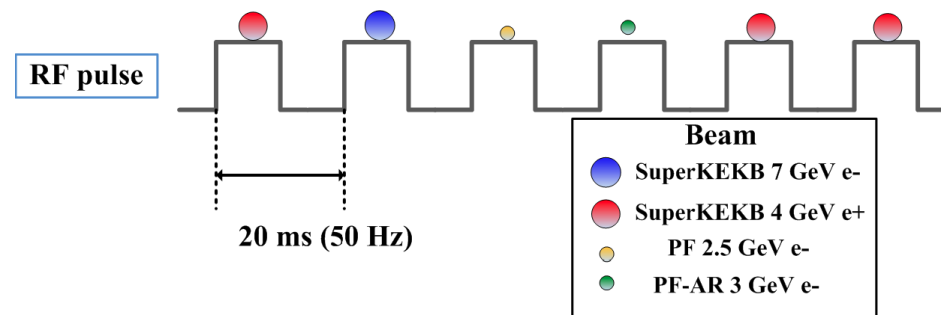

CLIC Main Beam Injector Complex



L. Rinolfi

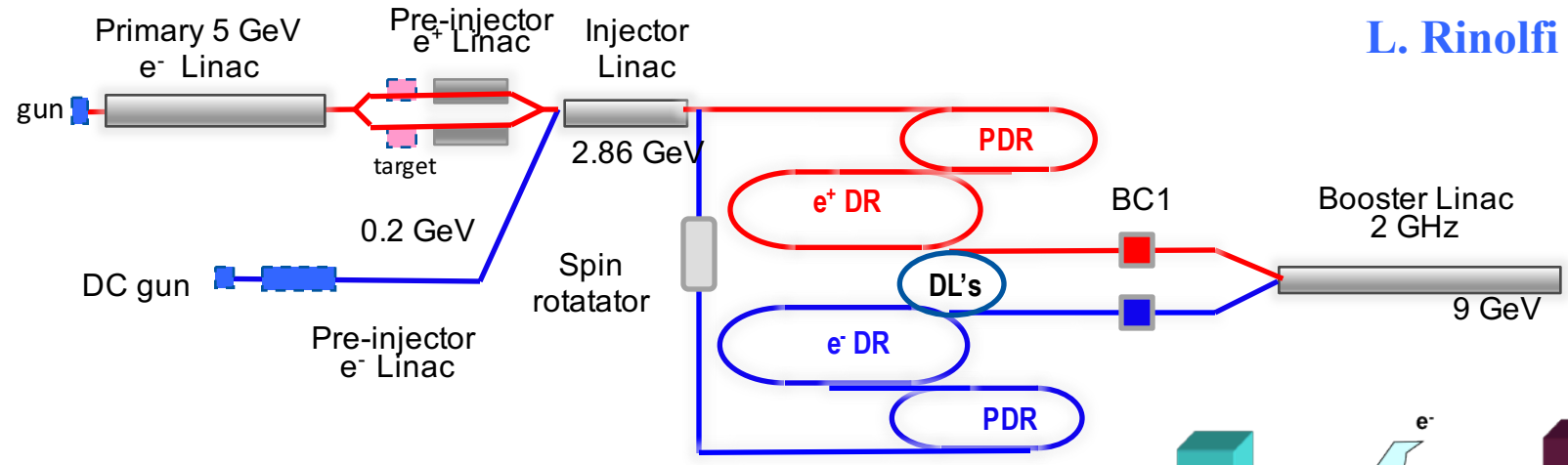

- Two hybrid positron sources (only one needed for 3 TeV collider)
- Common injector linac
- All linac's at 2 GHz, bunch spacing

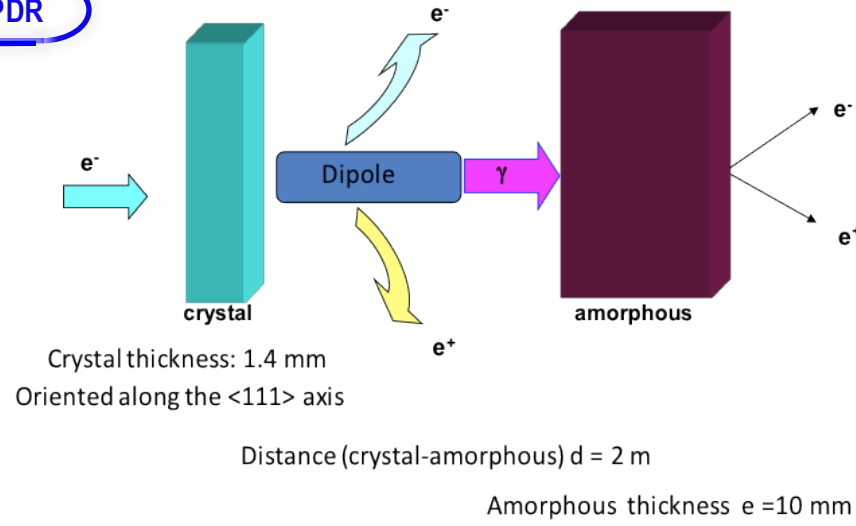

Positron flux for linear colliders



	SLC	CLIC (3 TeV)	CLIC (0.5 TeV)	ILC (RDR)	FCChe (pulsed)	FCChe ERL
Energy [GeV]	1.19	2.86	2.86	5	140	60
e ⁺ / bunch (at IP) [10 ⁹]	40	3.7	7.4	20	1.6	2
e ⁺ / bunch (aft. capture) [10 ⁹]	50	7	14	30	1.8	2.2
Bunches / macropulse	1	312	354	2625	100 000	NA
Rep. Rate (Hz)	120	50	50	5	10	CW
Bunches / s	120	15600	17700	13125	10 ⁶	20x10 ⁶
e ⁺ flux [10 ¹⁴ p/s]	0.06	1.1	2.5	3.9	18	440

- **SLS injector positron flux** flux already compatible with FCCee needs
- FCChe is orders of magnitude above FCCee requirements (challenging design)

L. Rinolfi

Possible FCC-ee injector scheme



- LINACs and positron production following a **CLIC version** (or upgraded LIL/CTF3)
- **2 GHz, 50 Hz** repetition rate, around **3.3×10^9 p/b**
 - **Other** LINAC frequency (e.g. **3 GHz**) is envisaged (see presentation of **S.Polozov** and appendix)
- Trains from **80 to 6100 bunches** (depending on the FCCee flavours) **injected 5 times in SPS @ 10GeV** in required **400 MHz bunch structure** and **accelerated to 20 GeV**
 - Need **new RF system** in the SPS (**400 MHz**) and required power (voltage)
- **SPS duty factor** of **0.5** or less leaving time for fixed target proton physics
- **5 cycles** (or less) of **1.2 s** in a supercycle of maximum **12 s** (1 cycle for the top)
- Injected into the booster ring on a **flat bottom** of **6 s** (or less) to be **accelerated in 3 s** to required extraction energy of FCC-ee
- **Interleaved injection** of positrons and electrons
- Filling time for full filling **20 min** for **FCCee-Z** (less for other flavours)
- **Top-up compatible** with all **required lifetimes** (down to **14.4 s** for both species)
- Alternative scenario with **new PBDR** is been worked out (see presentation of **Ö.Etischen**)

FCC-ee injector parameters



Accelerator	FCCee-Z		FCCee-W		FCCee-H		FCCee-tt	
Energy [GeV]	45.6		80		120		175	
Type of filling	Full	Top-up	Full	Top-up	Full	Top-up	Full	Top-up
LINAC # bunches	1830	6100	1315		780		80	
LINAC repetition rate [Hz]	50							
LINAC RF freq [MHz]	2000							
LINAC bunch population [10^9]	1.65	0.06	1.50	0.30	1.54	0.40	1.62	0.87
# of LINAC injections	5							
SPS/BR bunch spacing [MHz]	400							
SPS bunches/injection	366	1220	263		156		16	
SPS bunch population [10^{10}]	0.83	0.03	0.75	0.15	0.77	0.20	0.81	0.44
SPS duty factor	0.5		0.44		0.17		0.17	
SPS / BR # of bunches	1830/9150	6100/30500	1315/5260		780/780		80/80	
SPS / BR cycle time [s]	1.2 / 12		1.2 / 10.8		1.2 / 7.2		1.2 / 7.2	
Number of BR cycles	50	9	10	1	13	1	27	1
Transfer efficiency	0.8							
Total number of bunches	91500		5260		780		80	
Filling time (both species) [sec]	1200	216	216	21.6	187.2	14.4	388.8	14.4
Injected bunch population [10^{10}]	3.3	0.07	6.0	0.12	8.0	0.16	17.4	0.35

Booster design - Geometry

- Booster vs collider: same circumference, same tunnel, same emittance
- Cloned version collider “inner” quarter-ring, except the IR.
- Two-fold & mirror-symmetry.

D.Shwartz

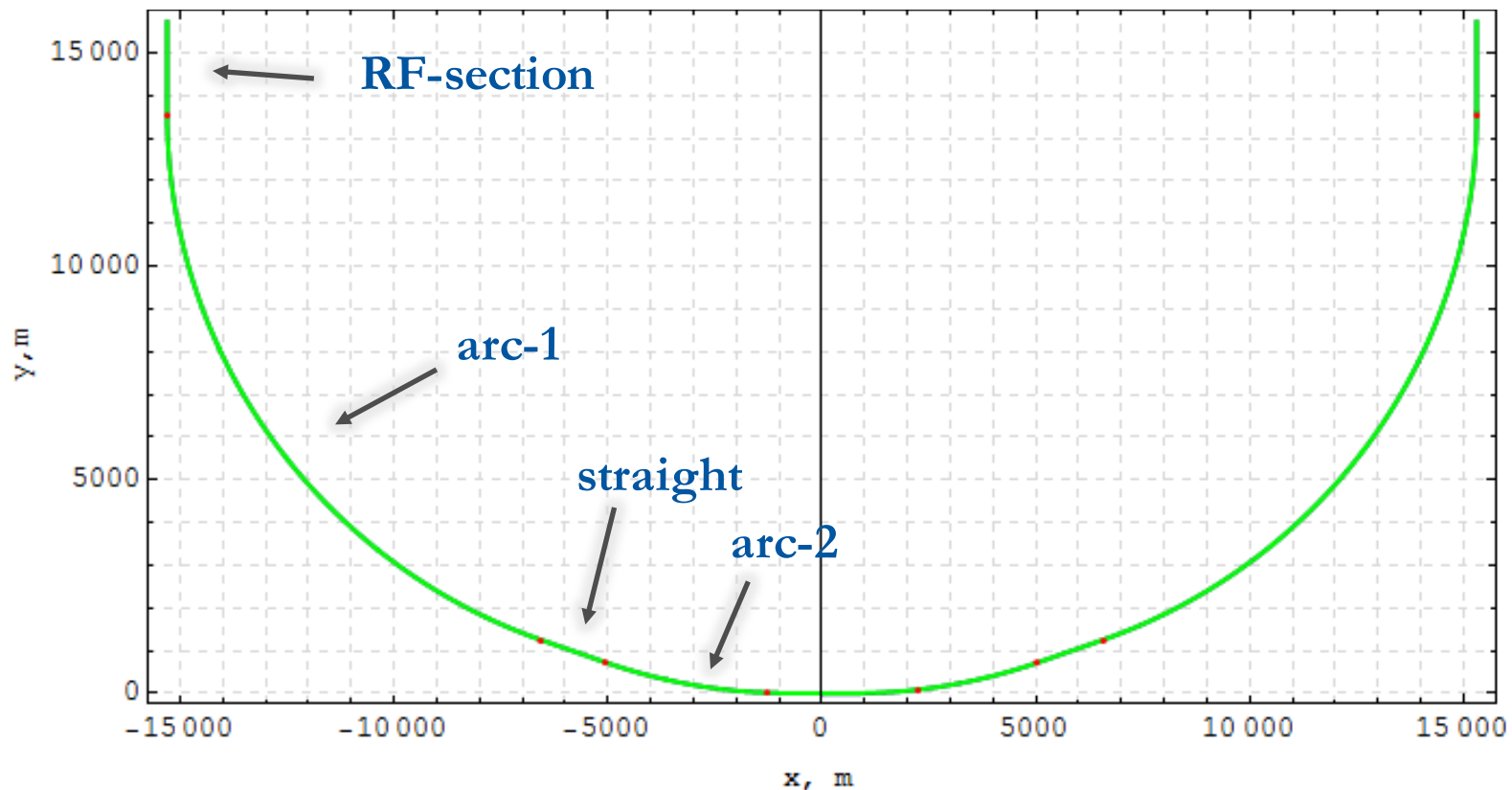

Booster design - Geometry



- Inner arc & bypass chosen to be compatible with FCC-hh

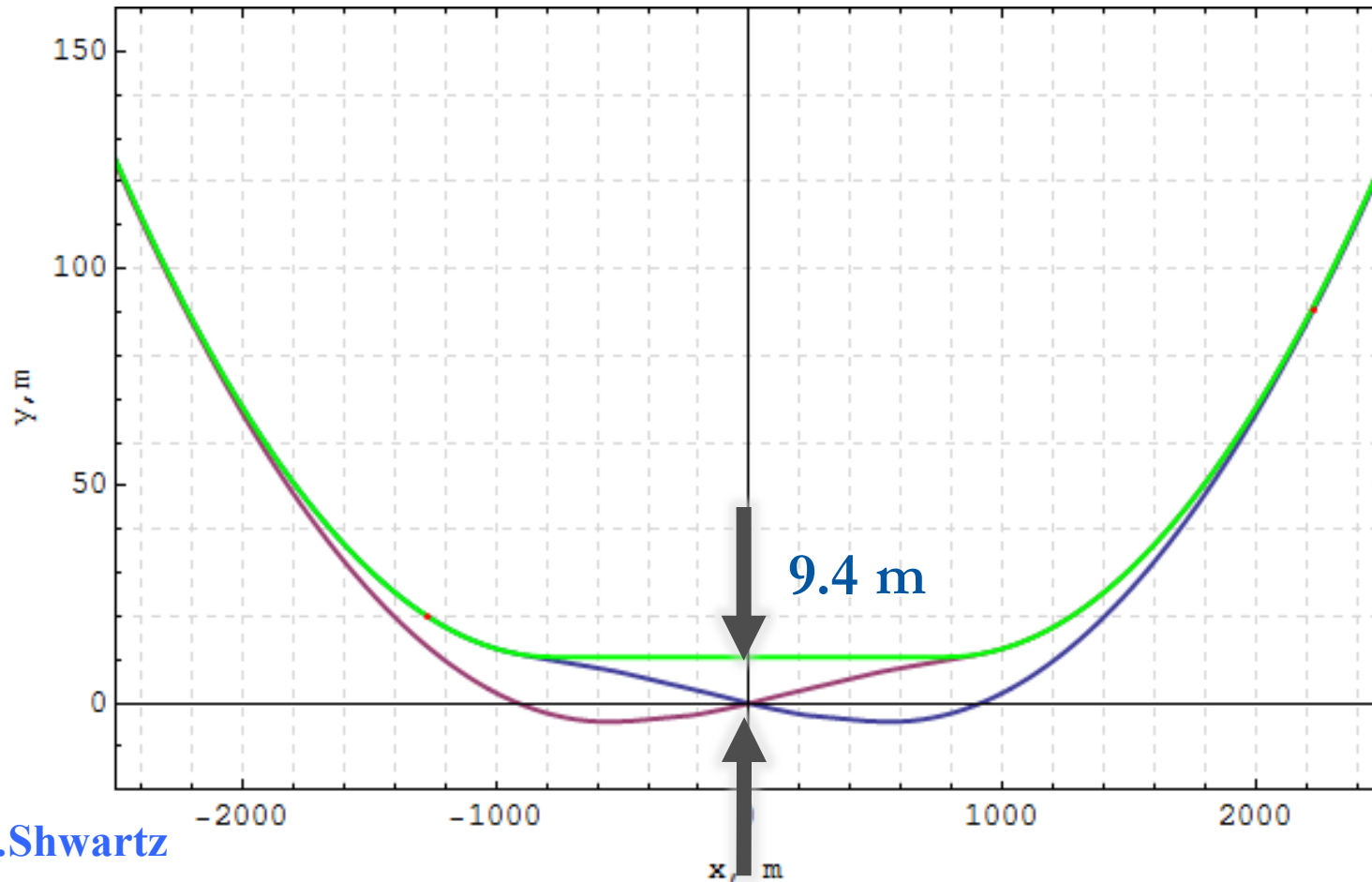

D.Schwartz

Optics



D.Shwartz

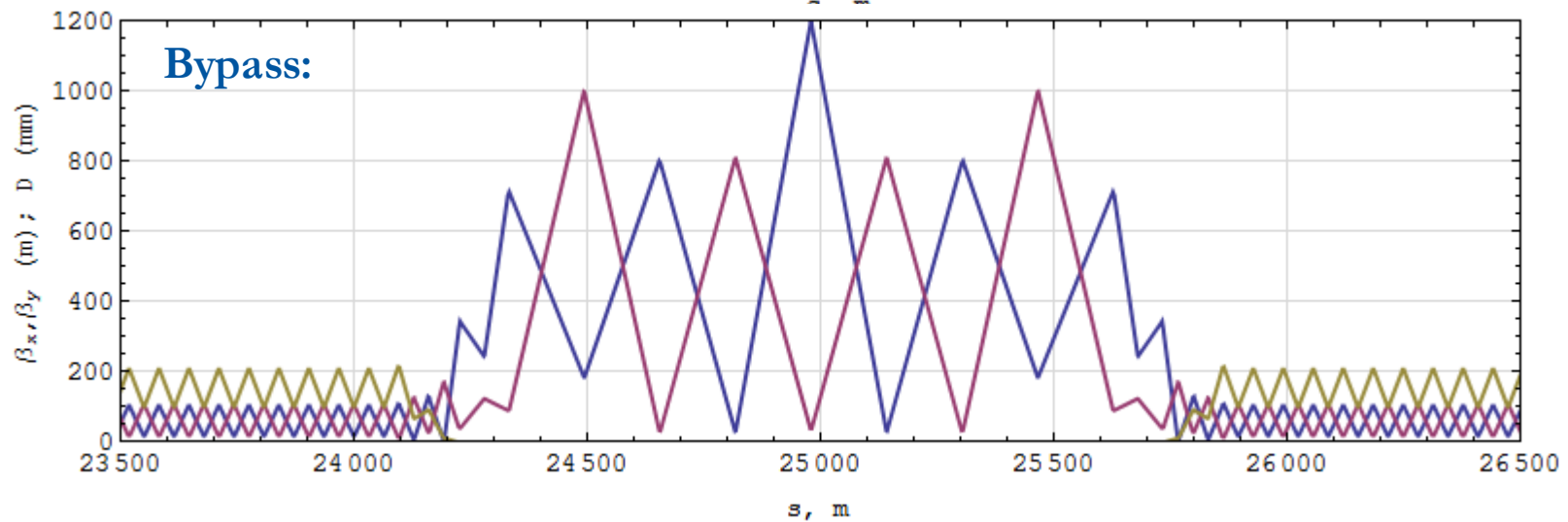
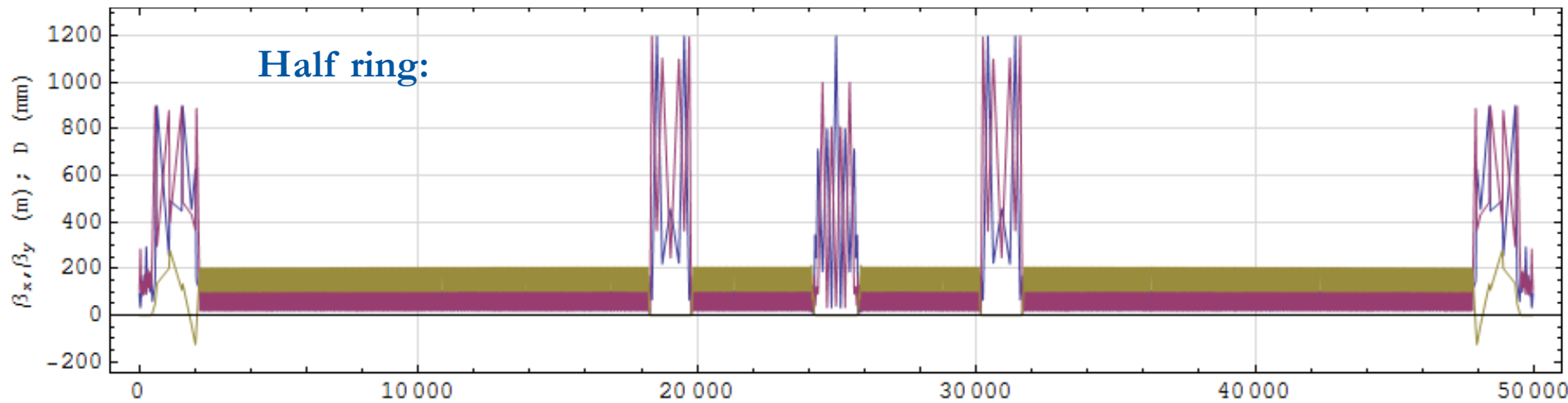

Booster Ring parameters



Top Energy [GeV]	45.6	80	120	175
Cycle time [s]	12			
Circumference [m]	99918.2			
Bending radius [m]	11653.8			
Injection energy [GeV]	20			
Dipole length	10.5			
Emittance @ injection [nm]	0.024			
Emittance @ extraction [nm]	0.12	0.38	0.85	1.8
Bending field @ injection [G]	57			
Bending field @ extraction [G]	129	229	343	509
Energy Loss / turn @ injection [MeV]	1.21			
Energy Loss / turn @ extraction [MeV]	31.1	310	1572	7109
Trans. Damping time @ injection [turns]	32974			
Trans. Damping time @ extraction [turns]	2895	516	153	50
Average current [mA]	36.3	19.0	2.9	0.31
Average power @ injection [kW]	44.1	23.1	3.5	0.4
Average power @ extraction [MW]	1.19	5.9	4.5	2.2
Average power over 1 cycle [kW]	96	544	630	306
Power from dipoles @ extraction [W]	171	847	651	317
Power density on bends @ extraction [W/m]	16	81	62	30
Critical energy [MeV]	0.02	0.10	0.33	1.02
Radiation angle [μ rad]	11.2	6.4	4.3	2.9

- **Low emittance @ extraction** obtained quite naturally due to the small bending angle
 - Good for injection efficiency and top-up
- **Ultra-low emittances @ injection** if keeping the same optics as for collider
 - Collective effect studies

Booster Ring parameters



Top Energy [GeV]	45.6	80	120	175
Cycle time [s]	12			
Circumference [m]	99918.2			
Bending radius [m]	11653.8			
Injection energy [GeV]	20			
Dipole length	10.5			
Emittance @ injection [nm]	0.024			
Emittance @ extraction [nm]	0.12	0.38	0.85	1.8
Bending field @ injection [G]	57			
Bending field @ extraction [G]	129	229	343	509
Energy Loss / turn @ injection [MeV]	1.21			
Energy Loss / turn @ extraction [MeV]	31.1	310	1572	7109
Trans. Damping time @ injection [turns]	32974			
Trans. Damping time @ extraction [turns]	2895	516	153	50
Average current [mA]	36.3	19.0	2.9	0.31
Average power @ injection [kW]	44.1	23.1	3.5	0.4
Average power @ extraction [MW]	1.19	5.9	4.5	2.2
Average power over 1 cycle [kW]	96	544	630	306
Power from dipoles @ extraction [W]	171	847	651	317
Power density on bends @ extraction [W/m]	16	81	62	30
Critical energy [MeV]	0.02	0.10	0.33	1.02
Radiation angle [μ rad]	11.2	6.4	4.3	2.9

- Energy loss/turn determined by energy and ring geometry
 - Same as for collider at extraction (**~ 1.2 MeV** at injection)
- Bending field at injection of **57 Gauss**
 - Should remain low as energy loss/turn at flat top already high
 - Compensation of eddy currents, hysteresis effects and appropriate shielding from FCC-ee main magnets is needed

Booster Ring parameters



Top Energy [GeV]	45.6	80	120	175
Cycle time [s]	12			
Circumference [m]	99918.2			
Bending radius [m]	11653.8			
Injection energy [GeV]	20			
Dipole length	10.5			
Emittance @ injection [nm]	0.024			
Emittance @ extraction [nm]	0.12	0.38	0.85	1.8
Bending field @ injection [G]	57			
Bending field @ extraction [G]	129	229	343	509
Energy Loss / turn @ injection [MeV]	1.21			
Energy Loss / turn @ extraction [MeV]	31.1	310	1572	7109
Trans. Damping time @ injection [turns]	32974			
Trans. Damping time @ extraction [turns]	2895	516	153	50
Average current [mA]	36.3	19.0	2.9	0.31
Average power @ injection [kW]	44.1	23.1	3.5	0.4
Average power @ extraction [MW]	1.19	5.9	4.5	2.2
Average power over 1 cycle [kW]	96	544	630	306
Power from dipoles @ extraction [W]	171	847	651	317
Power density on bends @ extraction [W/m]	16	81	62	30
Critical energy [MeV]	0.02	0.10	0.33	1.02
Radiation angle [μ rad]	11.2	6.4	4.3	2.9

- Average current considered for full filling, from a few to **~ 36 mA**
- Average power at injection up to **44 kW**
- Up to **~ 2.2 MW** at extraction
- Power density **exceeds 1W/m** in all extraction energies
 - Needs **shielding**

Booster Ring parameters



Top Energy [GeV]	45.6	80	120	175
Cycle time [s]	12			
Circumference [m]	99918.2			
Bending radius [m]	11653.8			
Injection energy [GeV]	20			
Dipole length	10.5			
Emittance @ injection [nm]	0.024			
Emittance @ extraction [nm]	0.12	0.38	0.85	1.8
Bending field @ injection [G]	57			
Bending field @ extraction [G]	129	229	343	509
Energy Loss / turn @ injection [MeV]	1.21			
Energy Loss / turn @ extraction [MeV]	31.1	310	1572	7109
Trans. Damping time @ injection [turns]	32974			
Trans. Damping time @ extraction [turns]	2895	516	153	50
Average current [mA]	36.3	19.0	2.9	0.31
Average power @ injection [kW]	44.1	23.1	3.5	0.4
Average power @ extraction [MW]	1.19	5.9	4.5	2.2
Average power over 1 cycle [kW]	96	544	630	306
Power from dipoles @ extraction [W]	171	847	651	317
Power density on bends @ extraction [W/m]	16	81	62	30
Critical energy [MeV]	0.02	0.10	0.33	1.02
Radiation angle [μ rad]	11.2	6.4	4.3	2.9

- **Critical energies @ extraction** as for the collider (up to **1.MeV** for highest energy)
- **Vertical radiation angle** of a few μ rad
- Needs demanding **shielding, absorption scheme** and **vacuum chamber design**

Summary



- Plenty of work to be done
- LINAC design (see **S.Polozov** presentation)
- Positron production
- Booster design
 - Booster integration in the tunnel
 - 50 Gs dipoles – practical possibility (cycling, shielding, stability, quality)
 - Polarization aspects & insertions
 - Linear optics (depending on energy?) and non-linear dynamics
 - IBS and collective effects
 - Injection to the collider (see **M.Aiba** presentation)

Thank you for your
attention

