

# Longevity Studies of the CDF-II Silicon Detectors

Roberto Martinez-Ballarín

CIEMAT, Spain

on behalf of the CDF silicon group



CMS workshop, Fermilab Nov-19-2008

# Outline

Location of Tevatron, CDF and the silicon detectors:

Challenge: extended lifetime of the CDF silicon detectors

CDF silicon subsystems L00 and SVX-L0

Radiation damage

Lifetime predictions

Monitoring techniques:

- Signal-to-bias scans

- Noise-to-bias scans

- Ratio of Signal to Noise

Other problems

Summary

# The Tevatron, the CDF experiment and the Silicon Detectors

Location of CDF at the Tevatron

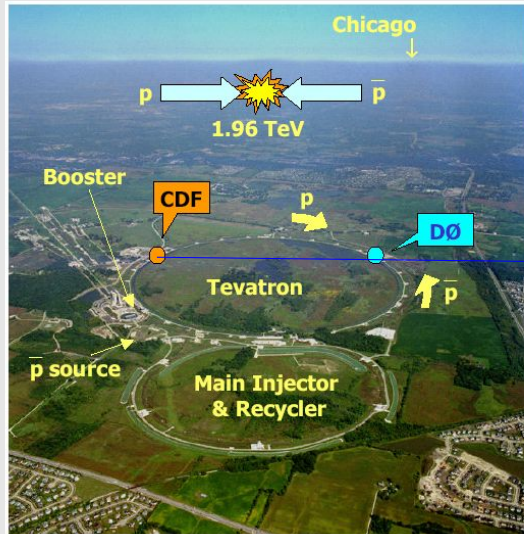

Location of the Silicon Detectors inside CDF

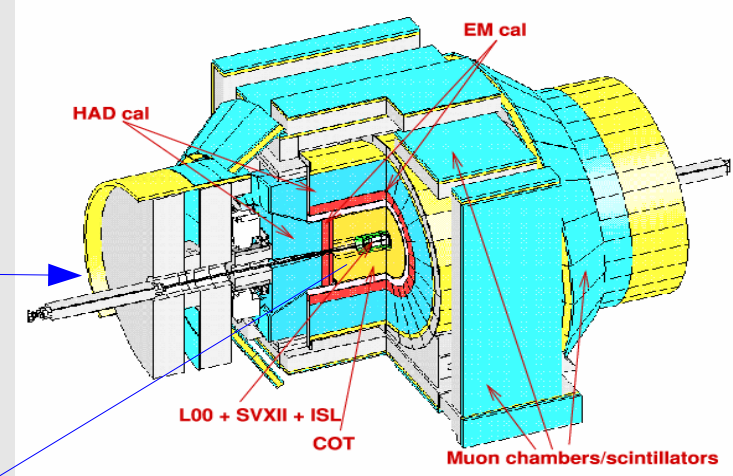

## L00

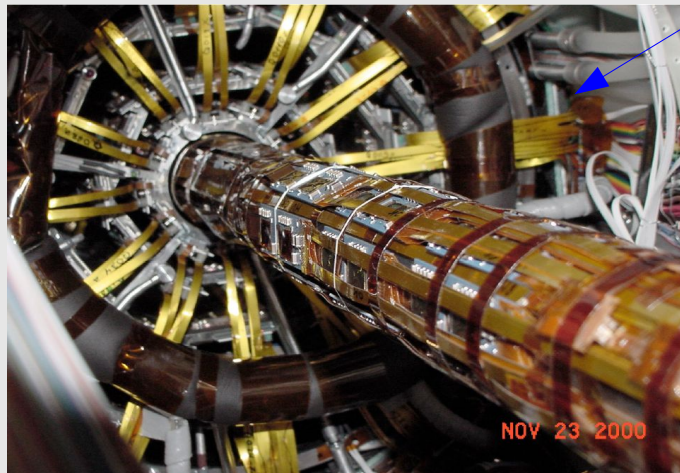

- Located in a very **high radiation environment**.
- Radiation causes changes in the detector: **type inversion, aging...**
- Radiation dose scales with luminosity and beam incidents
- Monitor the behavior of the detectors with time in order to **extrapolate** its future performance

# Challenge: extended lifespan of the CDF Run II silicon detectors

- The silicon detectors were originally designed to tolerate 2-3 /fb. but must now operate to the end of Run II with an expected luminosity of 7-9 /fb.
- The extended lifespan of the silicon creates aging effects: the depletion voltage of the sensor increases with time and the task of the Operations Group is to monitor it and adjust the bias voltage.
- Studies performed in 2004 showed operation was possible beyond design, assuming behavior after inversion were as predicted

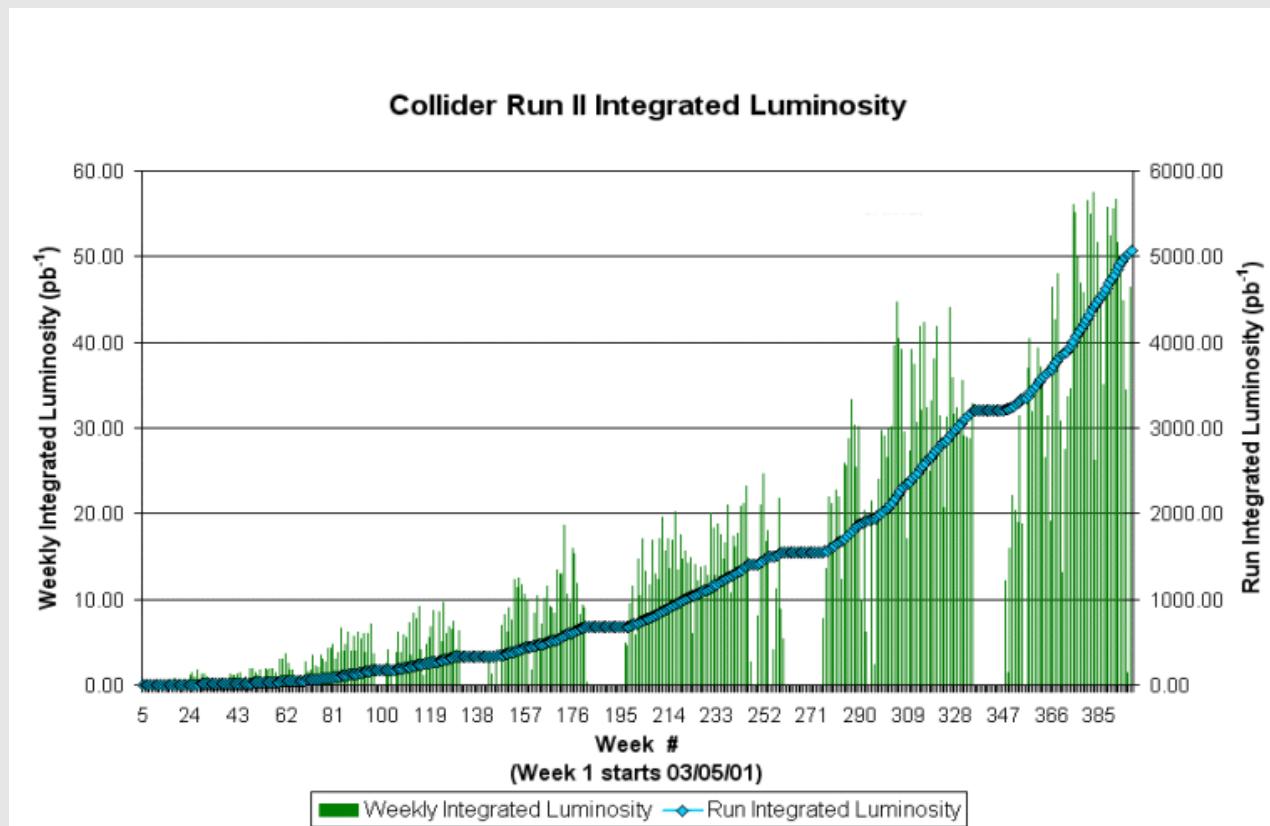

# Location and Description of the L00

- is the **closest** device to the beam-pipe: beam-pipe radius=1.2cm, sensor radii=1.35, 1.62cm
- 48 sensors (diodes), three kinds: Hamamatsu (36), SGS Thomson (10) and Oxygenated Micron (2). Strip pitch  $25\mu\text{m}$ .
- crystallographic  $\langle 100 \rangle$  silicon, **class of LHC sensors**
- operation limit of the bias voltage: 500 Volts (compared to 170 V for the SVX-L0 sensors)

SVX

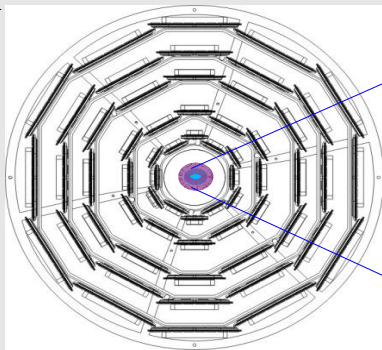

L00

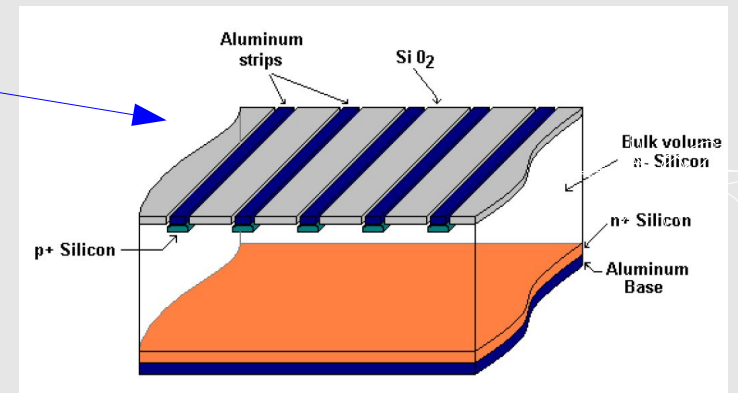
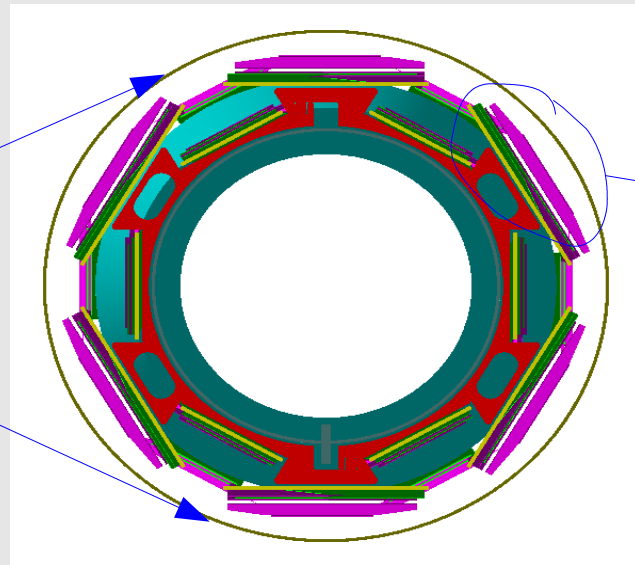

# Location and Description of SVX-L0

- 72 sensors (diodes), **double-sided: phi and z** (compared to single-sided L00), z side facing the beam.
- all of them made of crystallographic  $\langle 111 \rangle$  silicon (L00 and sensors for LHC made of  $\langle 100 \rangle$ ).
- operation limit of the bias voltage: 170 volts (compared to 500v for the L00 sensors)

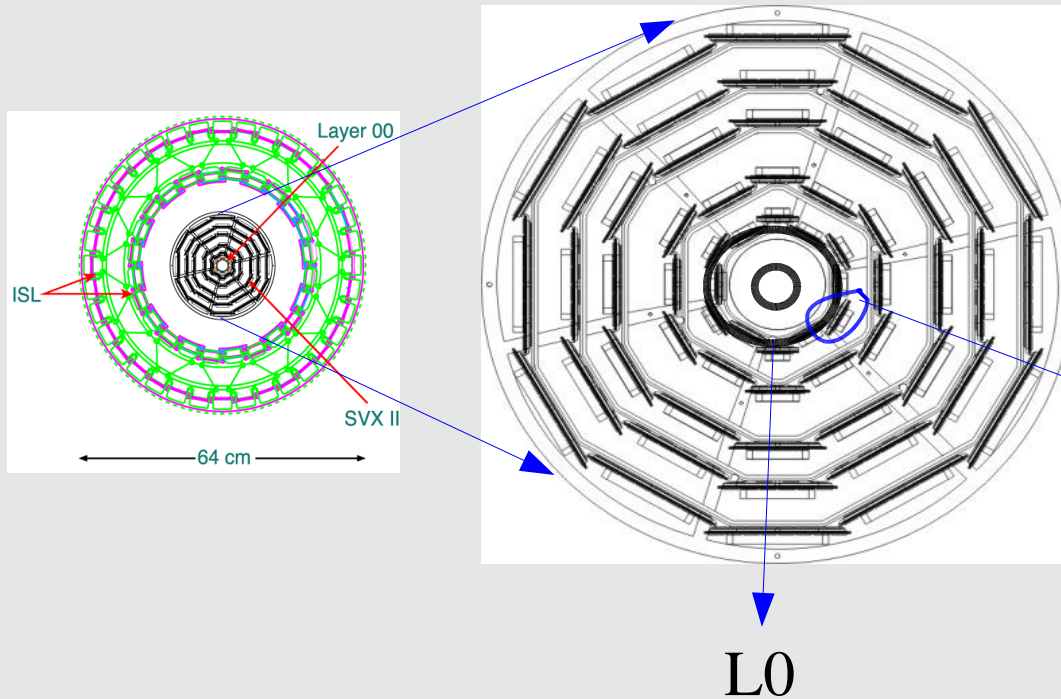

Double-sided sensors:  
Phi and Z sides.

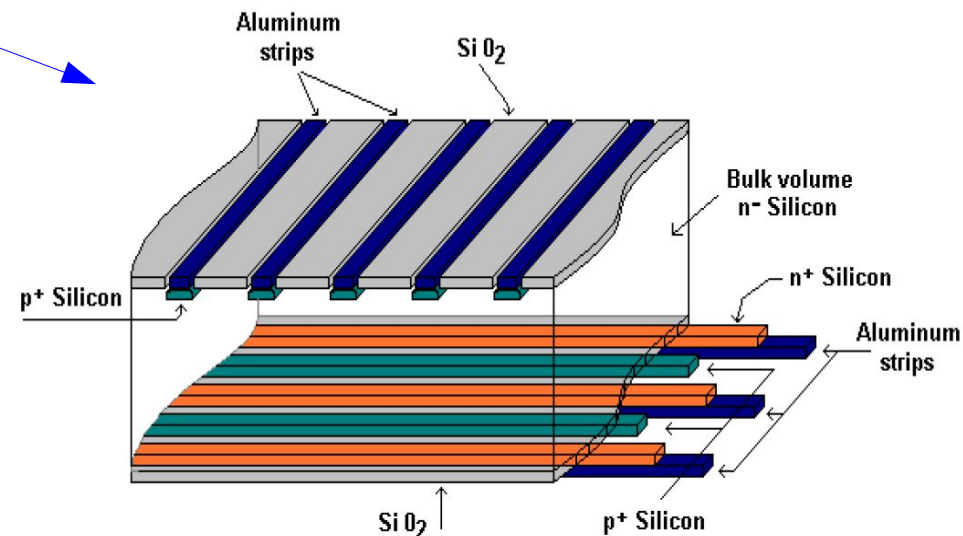

# Radiation-Induced Crystal Defects

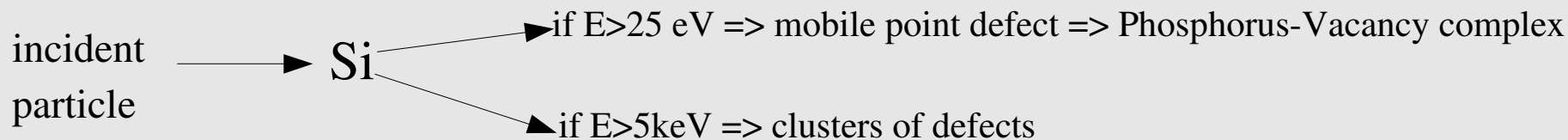
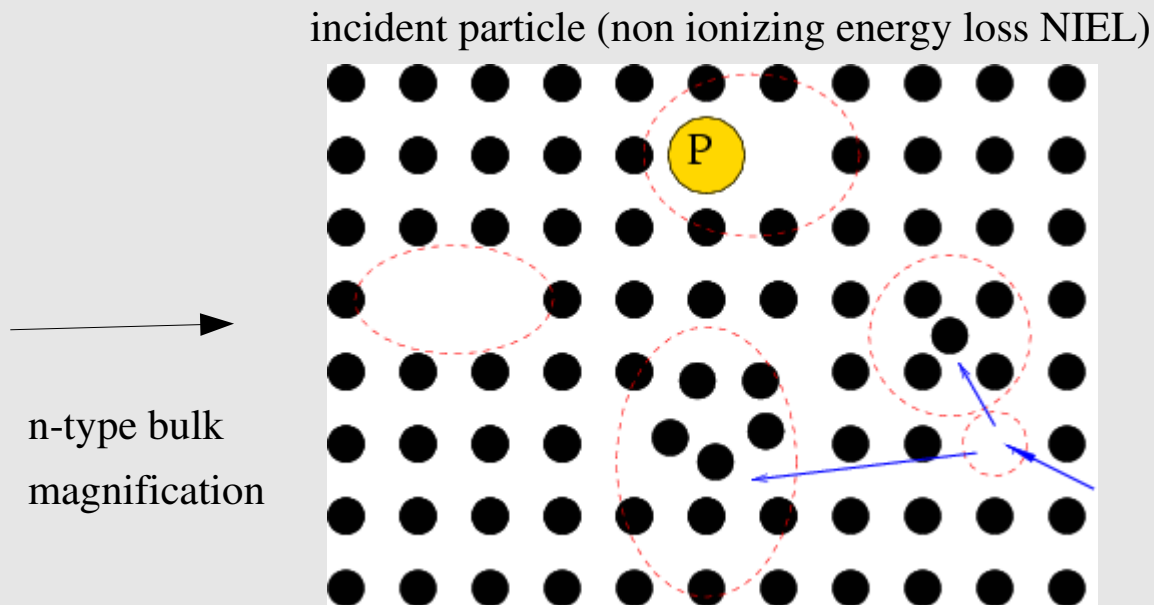
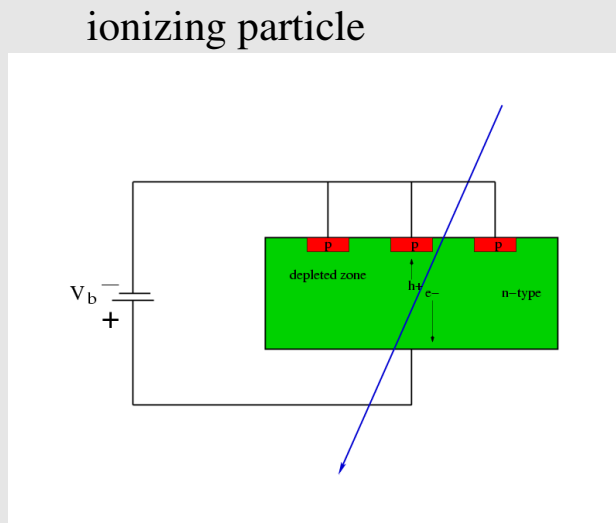

radiation => donor P removal (from + to 0) }  
 radiation => 'acceptor' creation (from 0 to -) } → **n-type inversion:** the effective dopant has changed the space charge from + to - in the depleted zone.

**absorbed radiation => change in time of the depletion voltage => monitoring of the detector needed**

# Lifetime prediction for the depletion voltage under irradiation: the Hamburg Model

$$\Delta V_{\text{dep}} \propto \Delta N_{\text{eff}} = N_A + N_C + N_Y$$

To monitor the depletion voltage we have two methods:

- signal-to-bias scan
- noise-to-bias scan

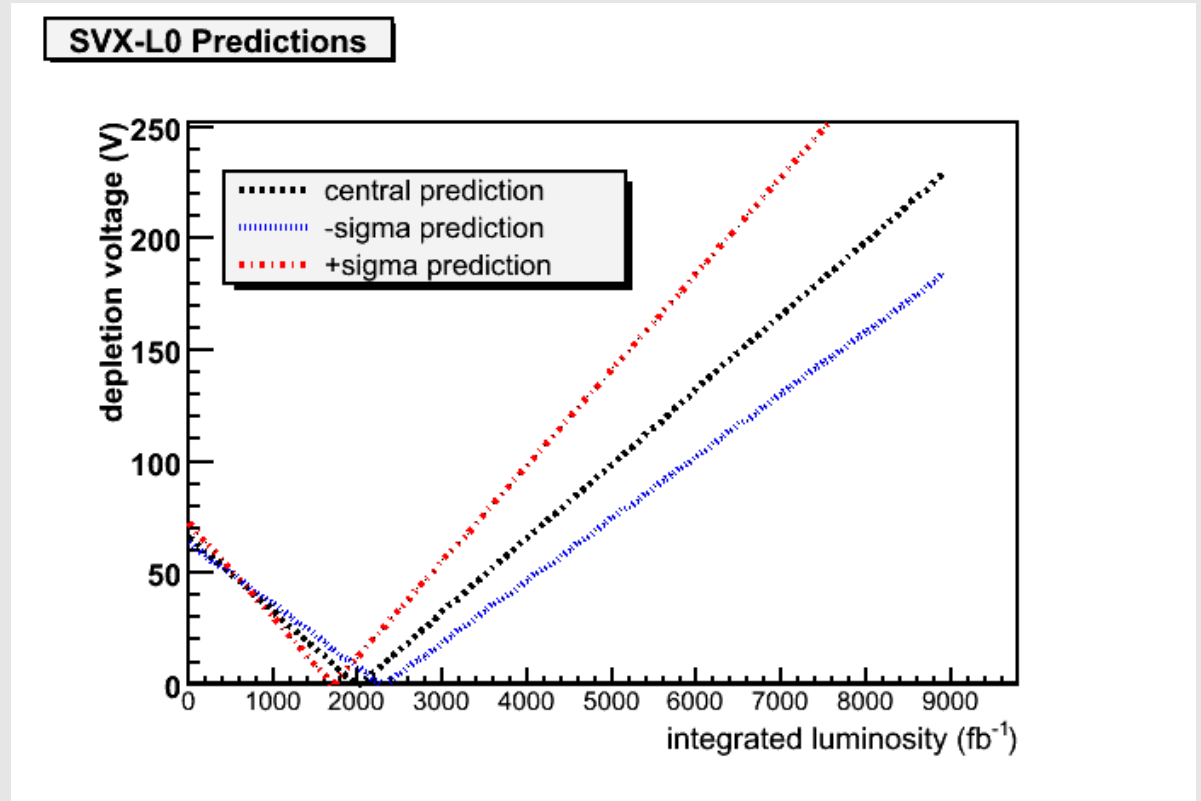

$$N_A = \Phi \sum_i g_{0,i} \exp[-c_{A,i}(T)t]$$

$$N_C = N_{C,0} (1 - \exp[-c\Phi]) + g_c \Phi$$

$$N_Y = g_Y \Phi \left( 1 - \frac{1}{1 + g_Y \Phi c_Y(T)t} \right)$$

beneficial annealing

cooling T=-10°C

stable component

reverse annealing



# Monitoring (I): Signal-to-Bias Scan Method

Record data (real events) **at a given bias-voltage**.

The charge collection distribution:

- fit the curve to a Landau convoluted by Gaussian
- extract the Most Probable Value (MPV)...

And **repeat** the process at other bias voltages.

- The set of MPVs corresponding to each one of **all the scanning bias-voltages** is fitted to a four parameters sigmoid.

- The voltage at 95% of the plateau is defined as the **depletion voltage** (for that sensor, at that luminosity).

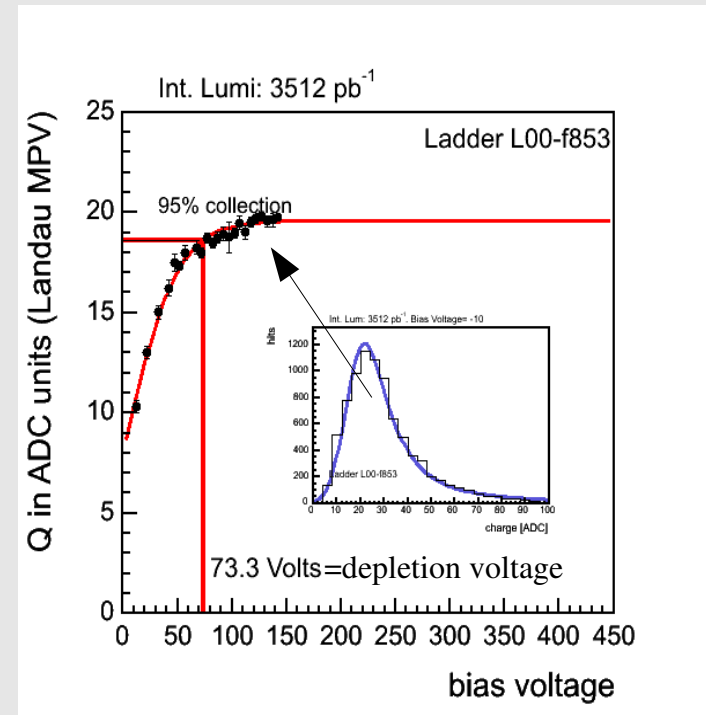
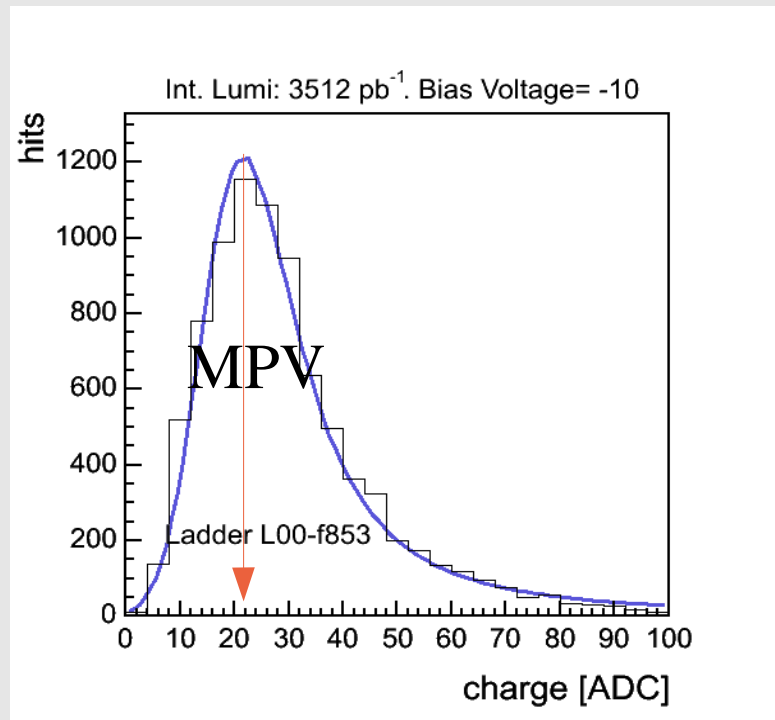

# Luminosity dependence of the L00 depletion voltages

- each bias-scan outputs a single point (depletion voltage) in the plots below.
- plotting the depletion voltages (for a given sensor) obtained at the different scans
- type inversion as a concavity in the red curve, its minimum being the **inversion point**.
- Oxygenated Micron sensors invert after the SGS Thomson or Hamamatsu, as expected.
- linear fit performed for points after the inversion point to extrapolate

Hamamatsu sensor

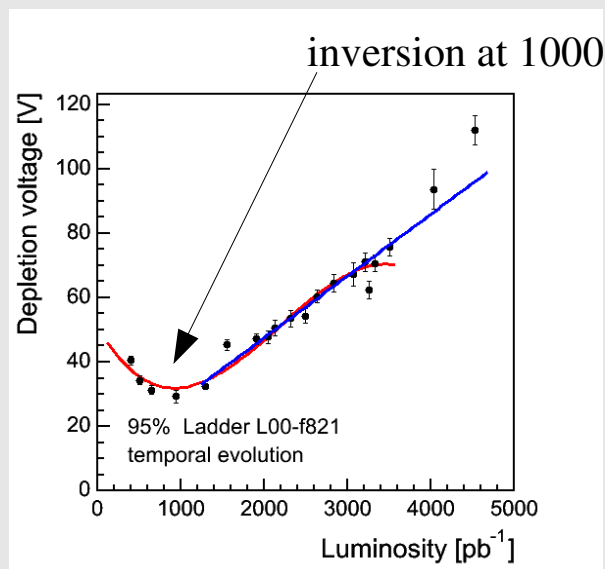

SGS Thomson sensor

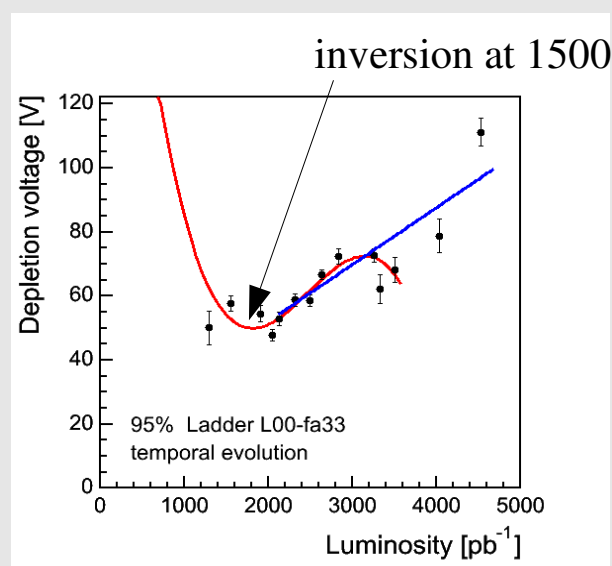

Oxygenated Micron sensor

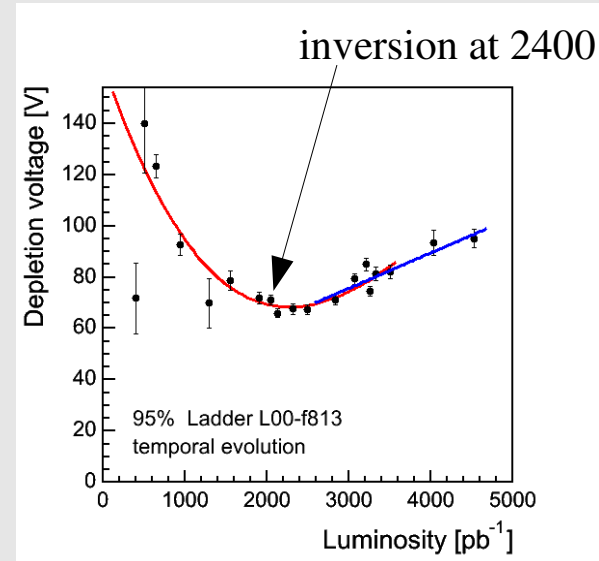

# Results of the Longevity Studies for L00

- display all the 48 linear fits of all the L00 sensors to have a general view of this layer
- at the current luminosity, all the L00 sensors are beyond inversion (increasing slope)
- all the L00 sensors are **inside the operation limits** even extrapolating to far luminosities

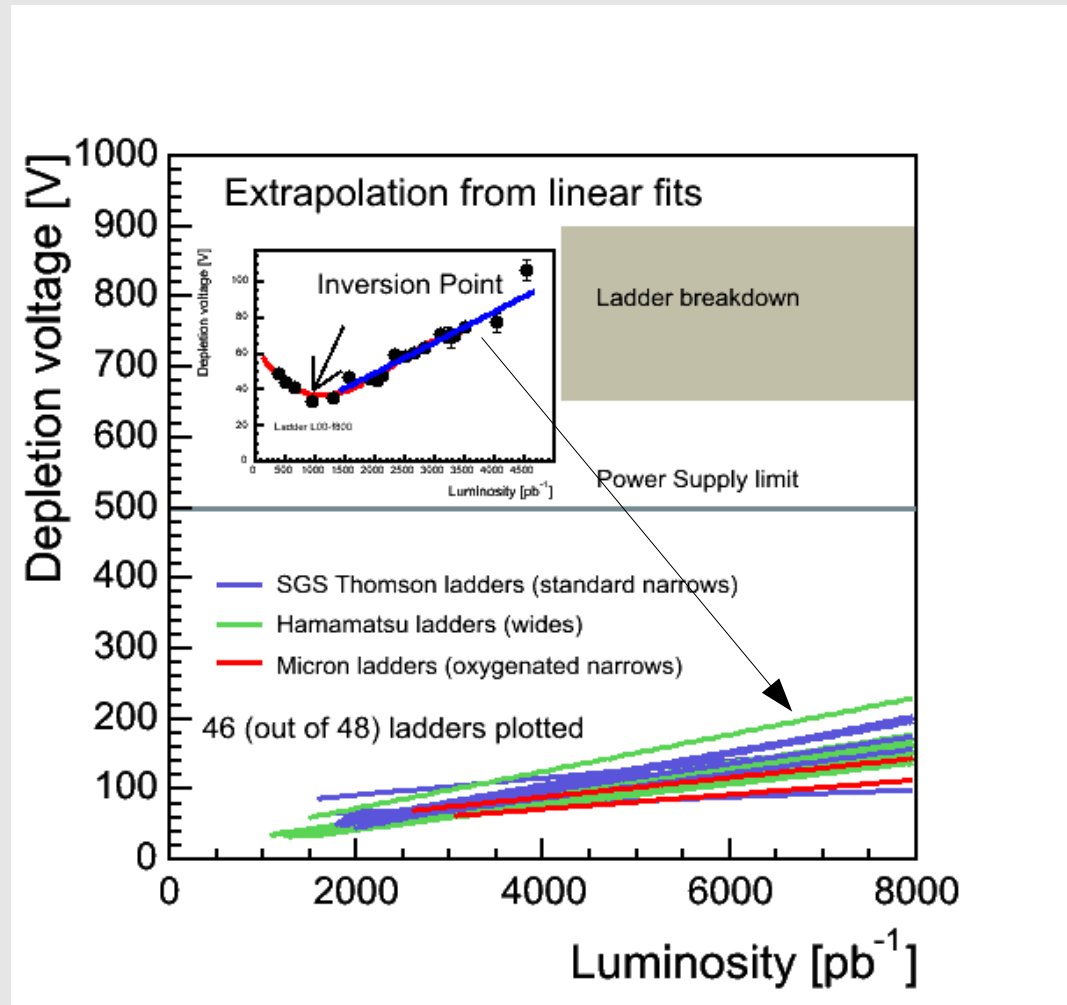

## Signal-to-bias scan results for SVX-L0

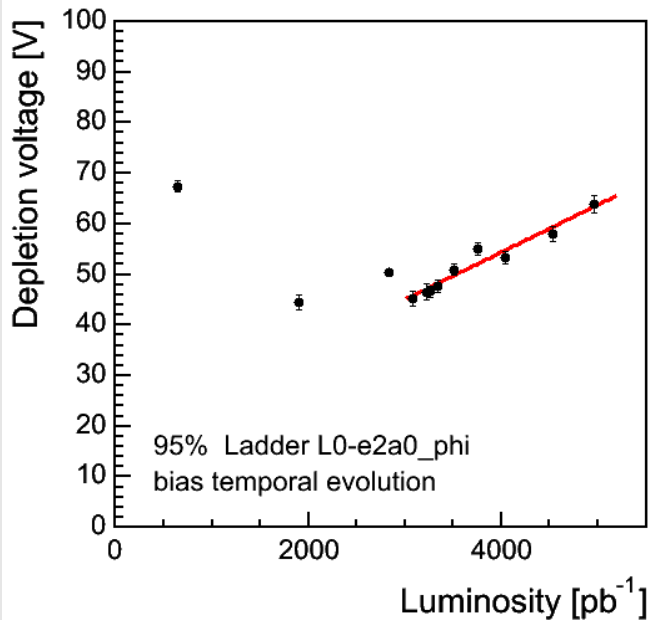

- same procedure as with L00: for every sensor linear fit the point beyond the inversion point

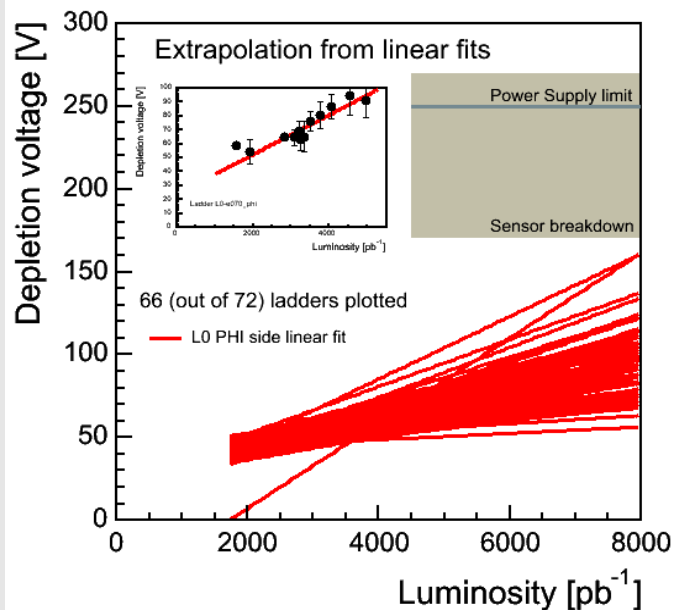

- behavior of all the SVX-L0 sensors
- all sensors have increasing slopes
- breakdown limit for the sensor will not be reached

# SVX-L0 data and predictions

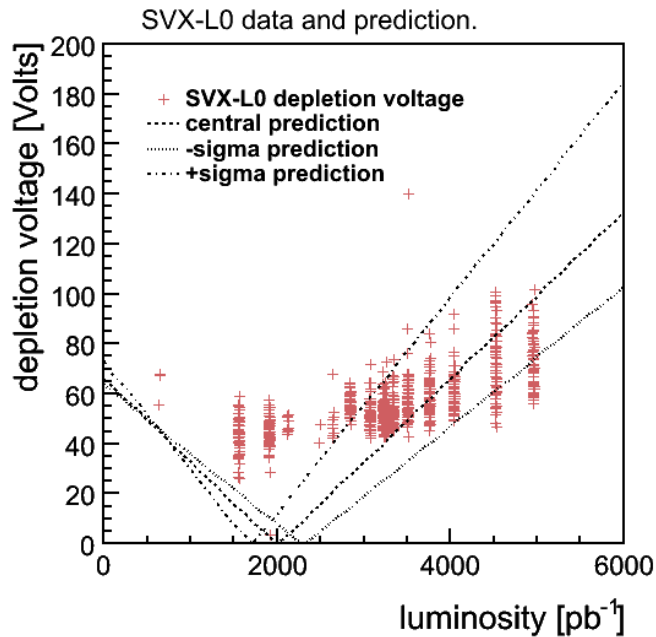

- values of all data of SVX-L0 sensors compared to the Hamburg Model prediction

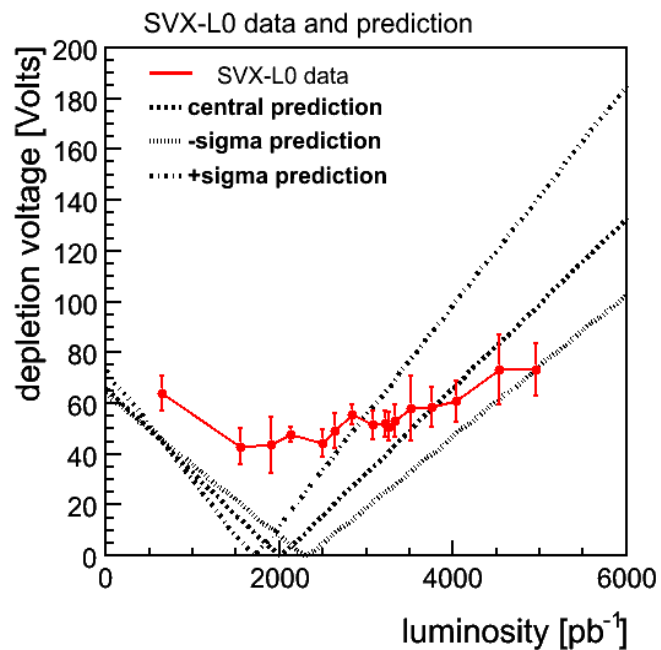

- average and spread of the points

## L00 and SVX-L0 sensors luminosity at inversion

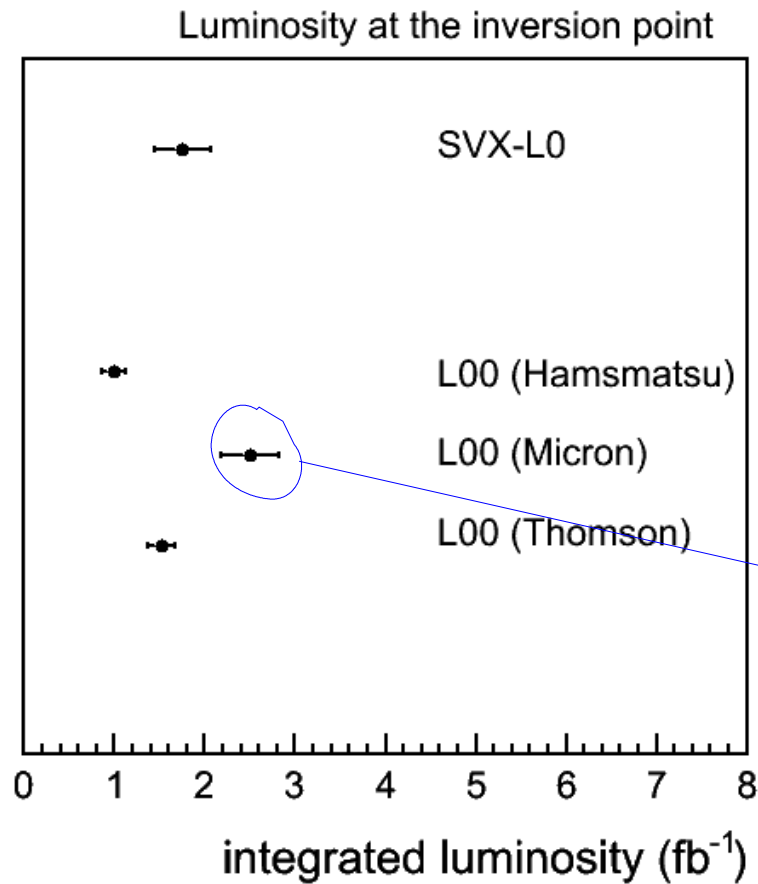

- separate the four different sensor type
- for each type plot an average of the luminosity at the inversion point
- L00 Micron Oxygenated was the best type delaying inversion

## Monitoring (II): Noise-to-Bias scans

- Taking advantage of the fact that **a depleted sensor has less noise**
- Bias the sensor with different depletion voltages and record noise
- When the noise curve saturates (95% reduction in noise between the two plateaus) the sensor is fully depleted
- No beam required, no interference with data-taking
- Unreliable after type inversion
- Method valid for double-sided sensors

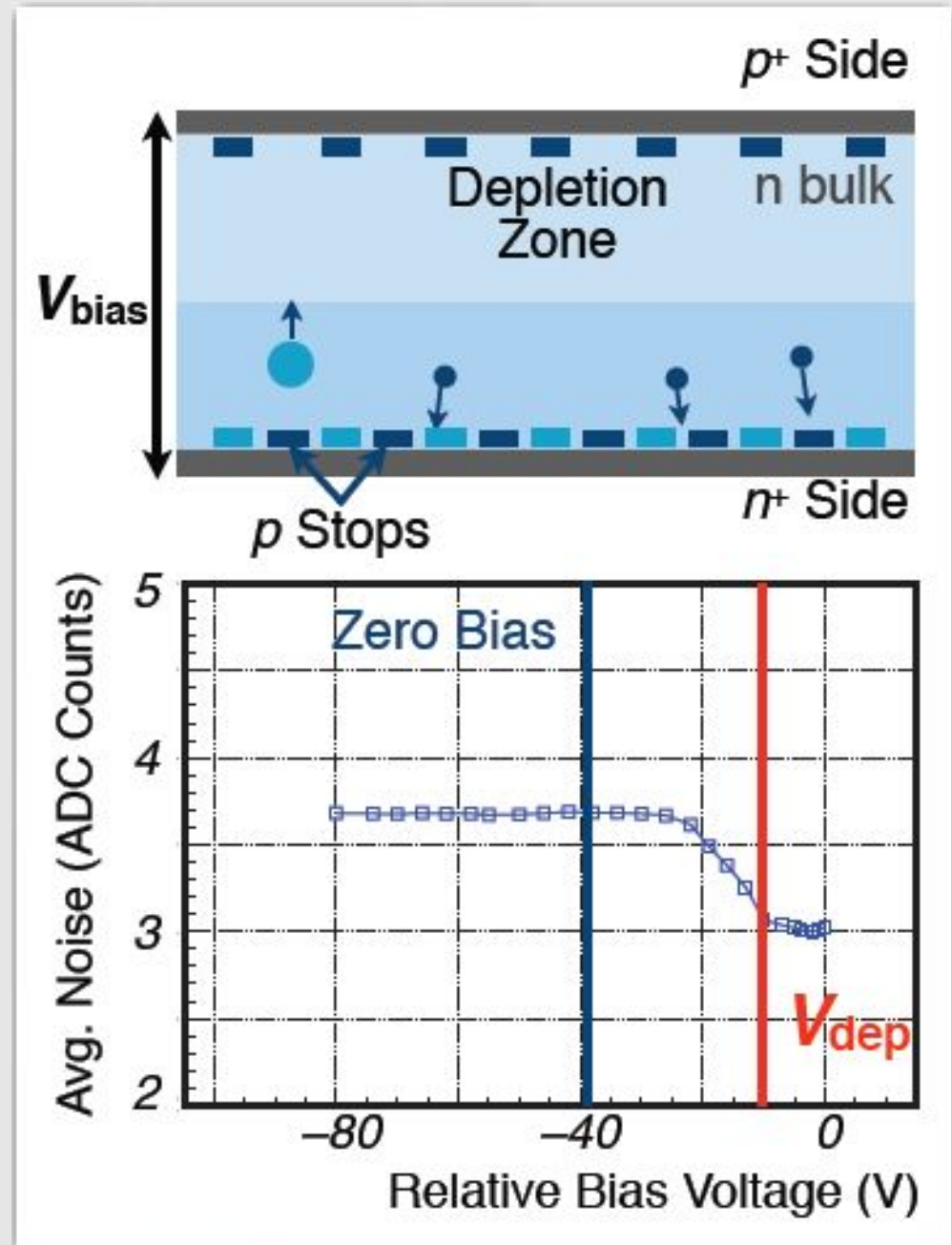

## Monitoring (III): Signal to Noise Ratio (S/N)

Ability to deplete sensors is important, but S/N ratio is really what matters: performance degrades even if well depleted so this rate has to be checked out.

Signal: charge collected when a charged particle crossed the sensor  
(data from  $J/\psi \rightarrow \mu \mu$  decays are used to measure the signal)

Noise: intrinsic noise of the detector

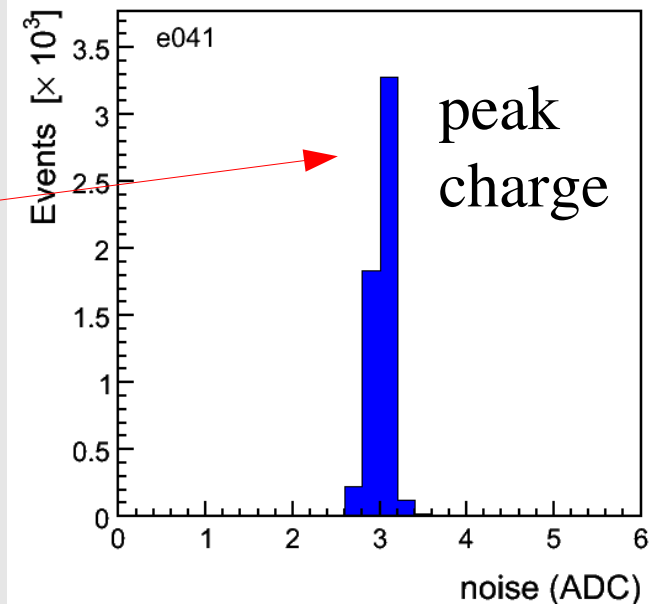
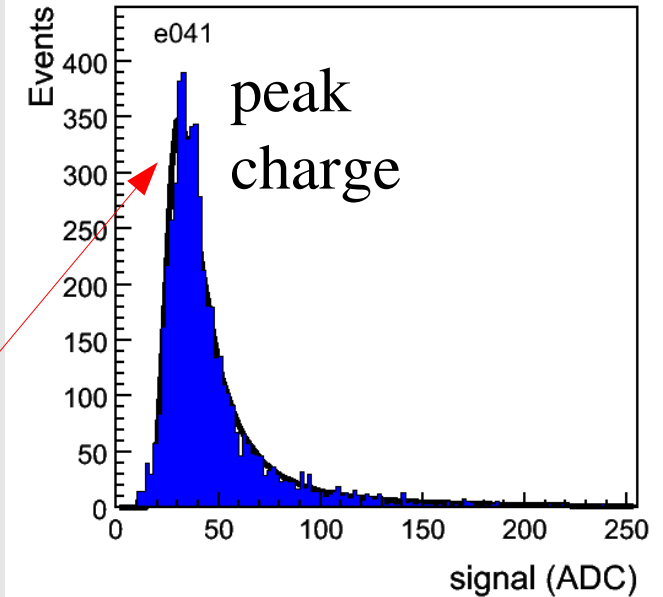



# SVX layers Signal to Noise results

- Limit:  $S/N < 8$  threshold for SVT trigger efficiency
- $S/N$  above 5-6 is very likely good physics
- If  $S/N \sim 3$  high pt B tag possible in Run I
- L0 careful monitoring to make it last to the end of Run II

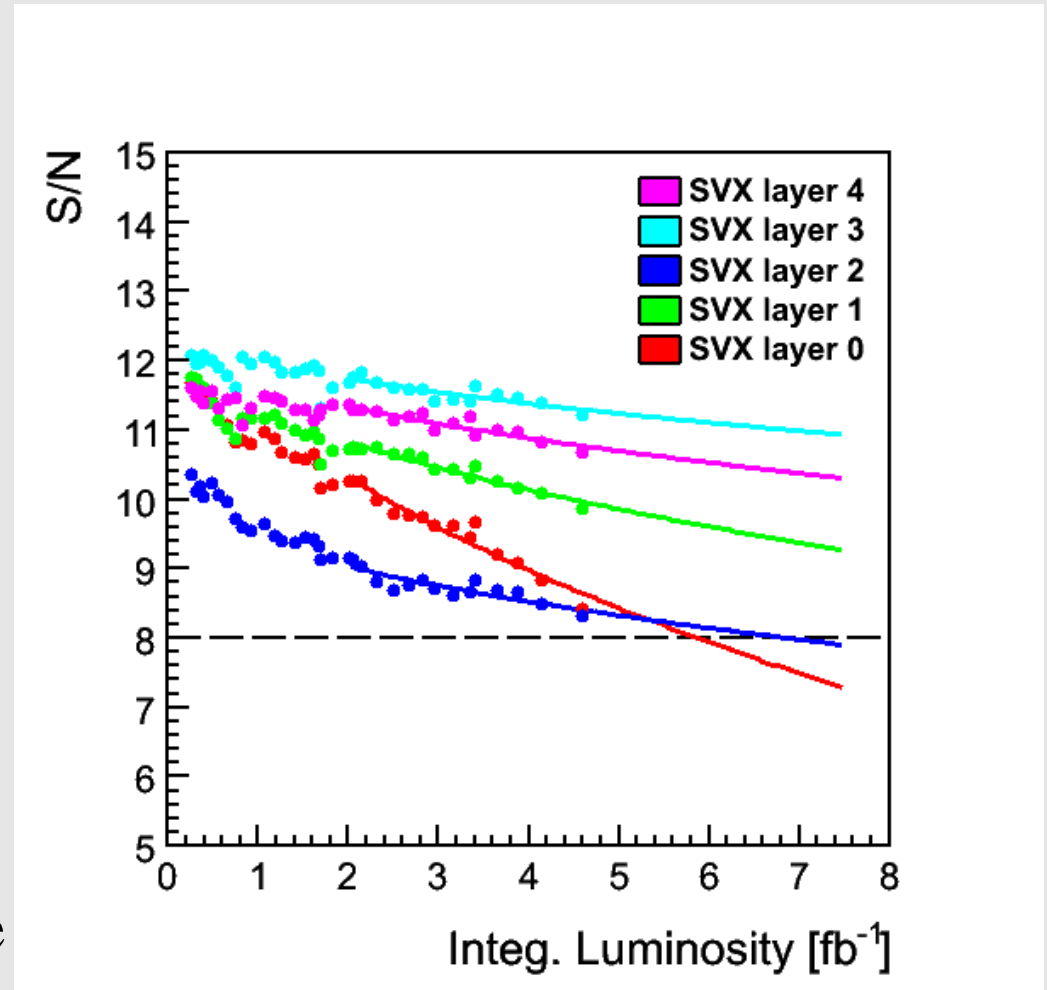

# Other Operational Issues

- Blocked Cooling lines
  - Blocked by glue, well inside the detector
  - **Solution:** open them up with a laser
- Acidification of coolant liquid
  - Half of L00 and SVX off for three months
  - **Solution:** de-ionizing resin
- Resonances
  - Wire bonds  $\perp$  to the magnetic field
  - Synch. Readout  $\rightarrow$  wire oscillate and break
  - **Solution:** Stop high frequency synchronous readouts.
- Beam Incidents
  - High dose accidentally delivered to the detector
  - **Solution:**
    - Collimators in key parts of the Tevatron
    - New Diamond based BLM system.

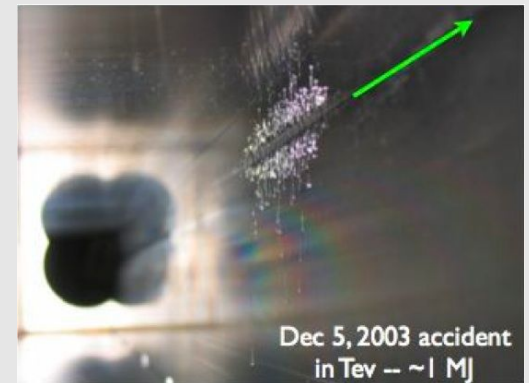
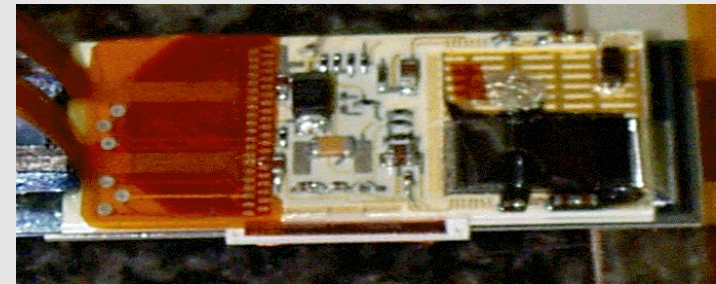
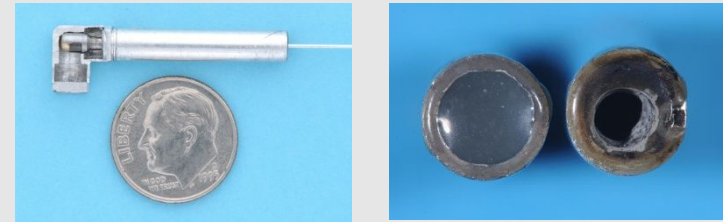

# Summary

- The CDF Run II silicon detector is fundamental for all branches of the CDF physics program: Bs mixing, top physics, Higgs searches...
- Radiation damage affects the detector's performance and **two variables** have to be monitored: **Depletion Voltage and Signal-to-Noise ratio.**
- Depletion Voltage can be measured by **two independent ways**: Signal-to-Bias scan and Noise-to-Bias scan
  - Signal scan needs beam time
  - Noise scan does not need beam but is only reliable before type inversion
- Signal-to-Noise ratio is a useful computation to monitor the quality of the detector and performance from the physics point of view.
- Even the innermost layers will be in **good operating conditions** until the end of Run II

# **Backup Slides**

# Type inversion under irradiation

Observed in Si detectors: n-type bulk  $\rightarrow$  i-type  $\rightarrow$  “p”-type

Many and competing effects, simply parametrized in:

- 1- removal of donor and acceptors
- 2- creation of donors and acceptors

The predominant charge states formed in Si are acceptor-like.

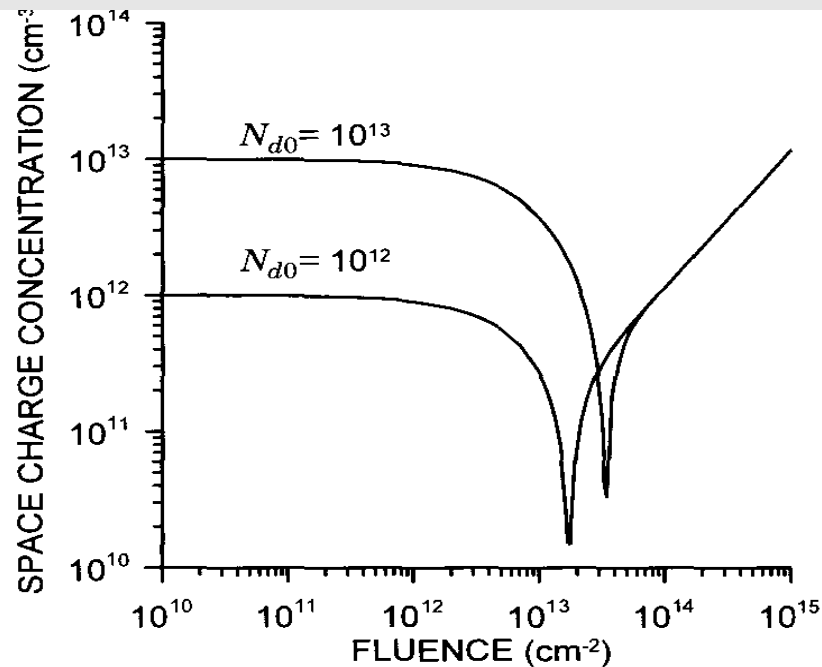

# Generation/Recombination in the Depletion Region via Intermediate States (I).

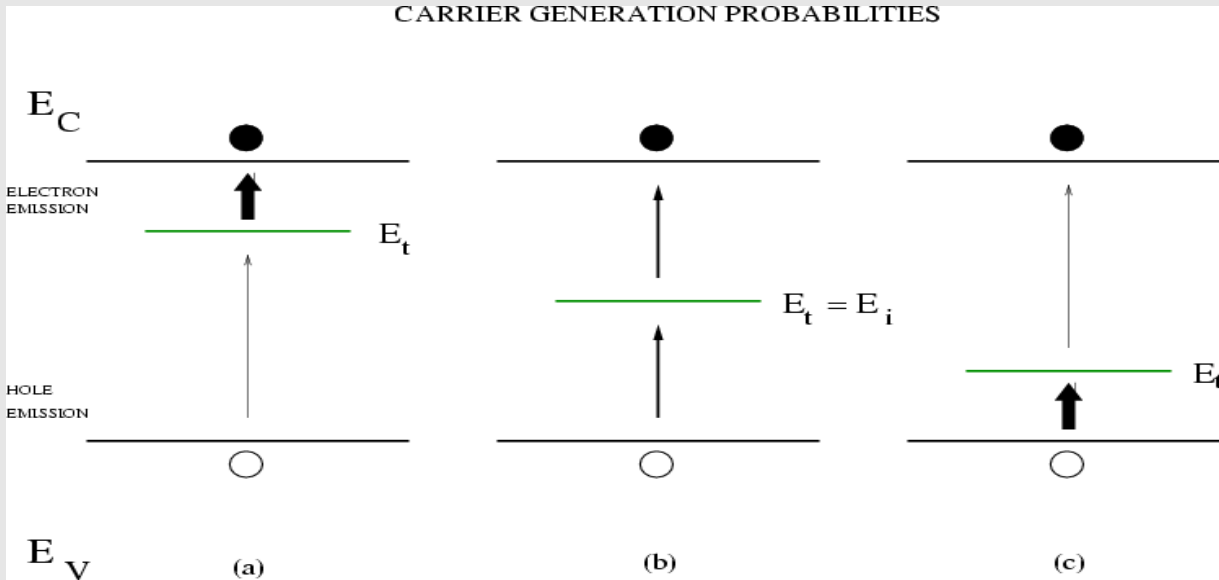

**HOLE EMISSION:** the process of hole emission from a defect can also be viewed as promoting an electron from the valence band to the defect level.

**ELECTRON EMISSION:** in a second step this electron can proceed to the conduction band and contribute to current flow, generation current.

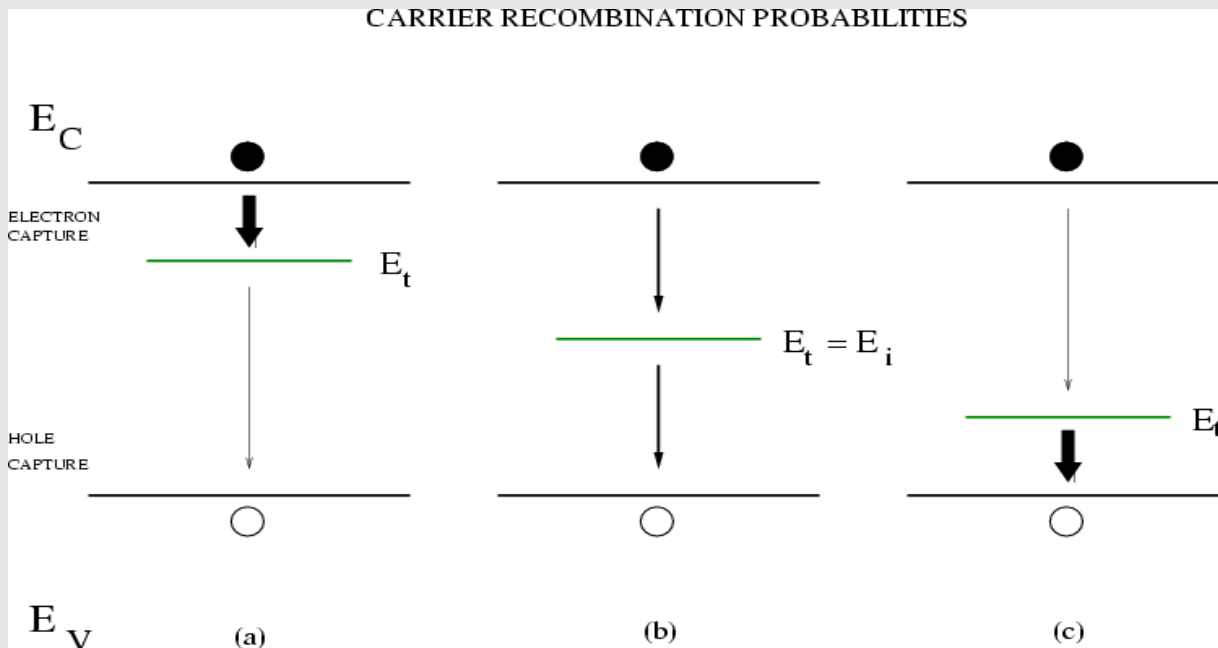

(does not affect in reverse-biased sensor)

**ELECTRON AND HOLE CAPTURE:** conversely, a defect state can capture an electron from the conduction band, which in turn can capture a hole. This recombination reduces current flowing in the conduction band.

# Generation/Recombination in the Depletion Region via Intermediate States (II).

GENERATION: In a diode operated with reverse bias (ie SVX), all of the carriers are swept from the depletion region, so there are no free carriers available for capture and recombination: only emission processes are important. Emission, in the absence of capture, can only proceed by alternating hole and electron emission (electron-hole pairs). From the previous probabilities, since the emission probabilities for electrons and holes increase exponentially with the separation from their respective band edges, the probability for sequential hole and electron emission is maximum at mid-gap. The emission rate of carriers leads to an electrical current: **the generation current**, which increases with the density of centers.

RECOMBINATION: Responsible of loss of signal charge in detectors (reverse bias). A center close to the conduction band will have a higher occupancy of electrons than holes, so the recombination rate is limited by the hole population. Conversely, a center close to the valence band will have a higher population of holes, so the population of electrons limits the recombination rate. This rate is maximum when the energy of the recombination center is at mid-gap.

Recombination is important whenever the carrier concentration deviates from thermal equilibrium. This occurs

-with incident radiation and bias=0 and

-in forward biased diode

The origin of recombination and generation centers are:

1-impurity atoms

2-structural imperfections

3- radiation damage

# Single and Double Sided Sensors

Subdividing an electrode into strips provides:

1-D position sensing (single sided L00)

2-D position sensing (double sided SVX, ISL)

Arranging (cylindrical 7 layers, 700 sensors) provides:

3-D position sensing

In both cases: charge collection efficiency => fully depleted sensor

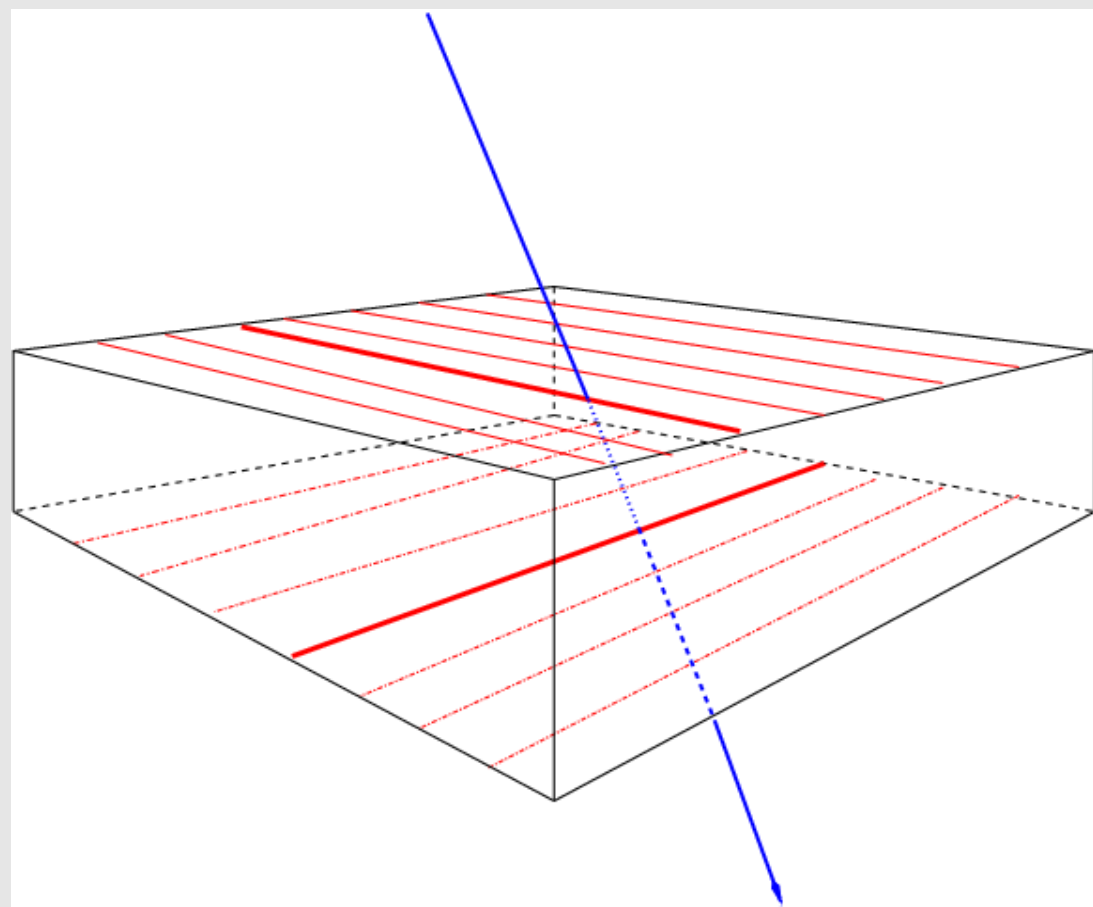
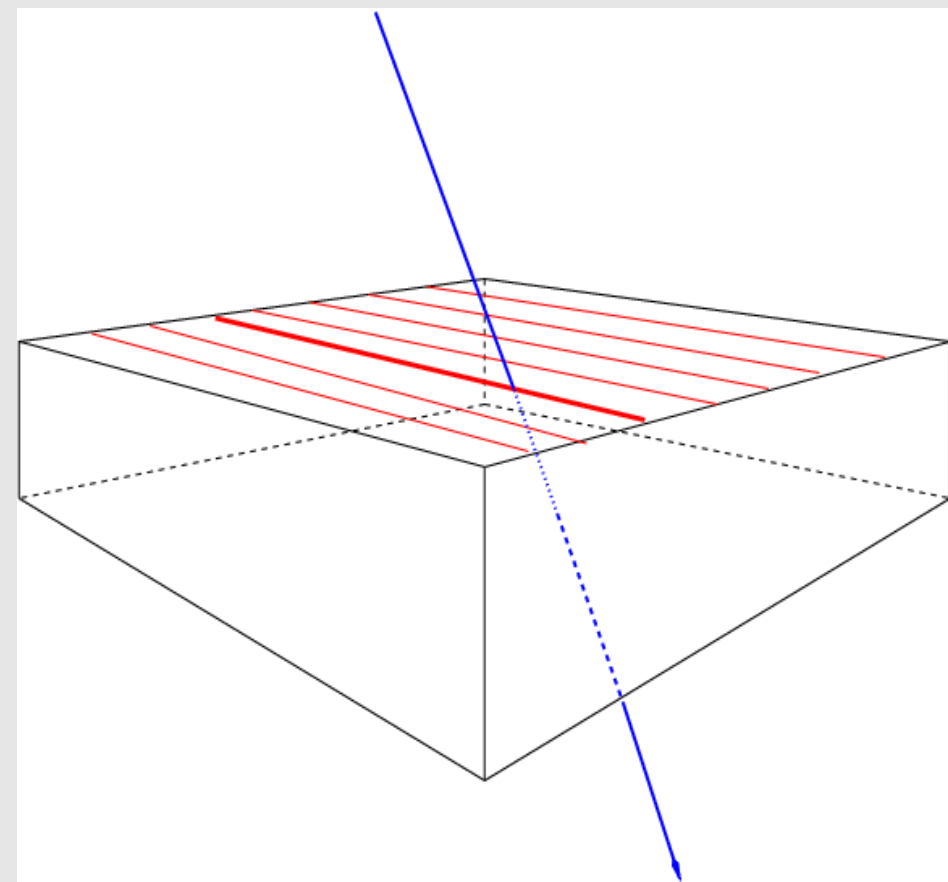



# Fits to Landau peak vs. bias V

- Function is modified Fermi-Dirac distribution function:

$$f(V) = \frac{B}{1 + e^{-(V-D)C}}$$

B = Depletion charge(ADC)

C ~ slope

D = Voltage at half depleted

- Modified so that V(95%) is fit instead of D.

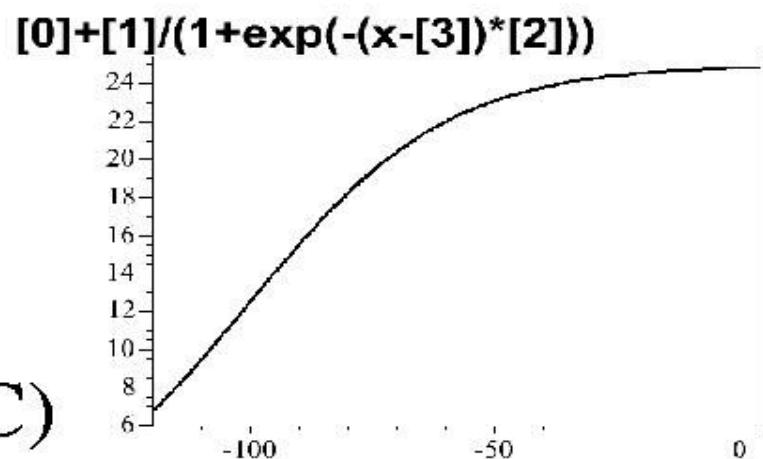

## 1-pn junction

unbiased

(natural depletion zone)

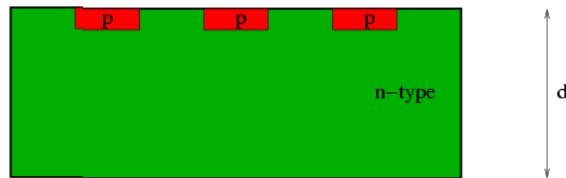

## Sensors and Depletion Voltage

- free charge carriers overwhelm ionization carriers => free charge carriers must be removed.
- Applying a reverse-bias to a pn junction creates an artificial depleted zone, without free charge carriers.
- The **depletion voltage** is defined as the voltage that fully depletes the semiconductor.
- In this condition, the device is useful as radiation sensor, able to collect the charge released by an ionizing particle.

## 2-polarization

reverse-biased

(artificial depletion zone)

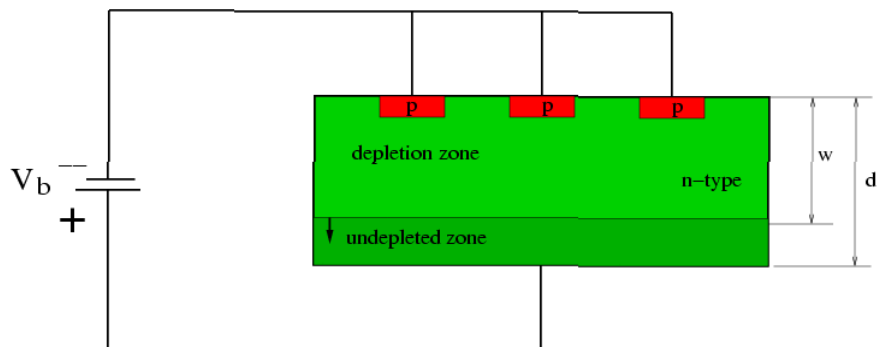

## 3-ionization

spatial information

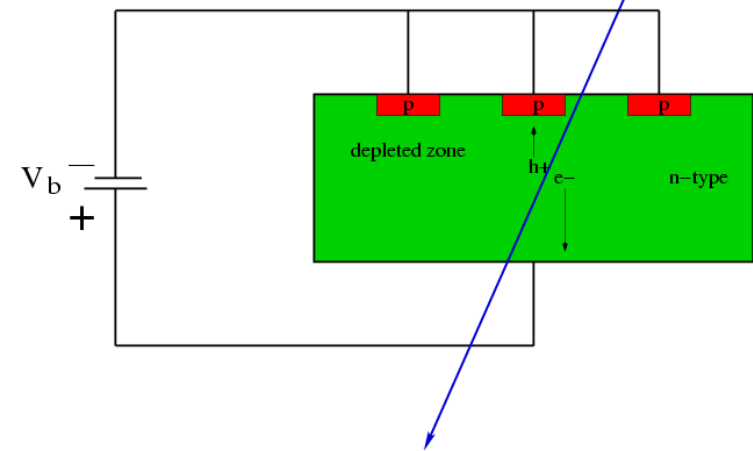

# Radiation-Induced Crystal Defects

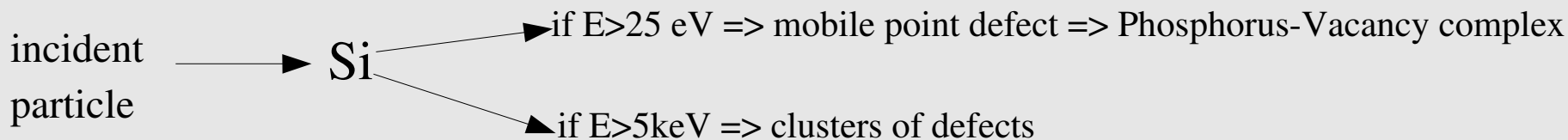
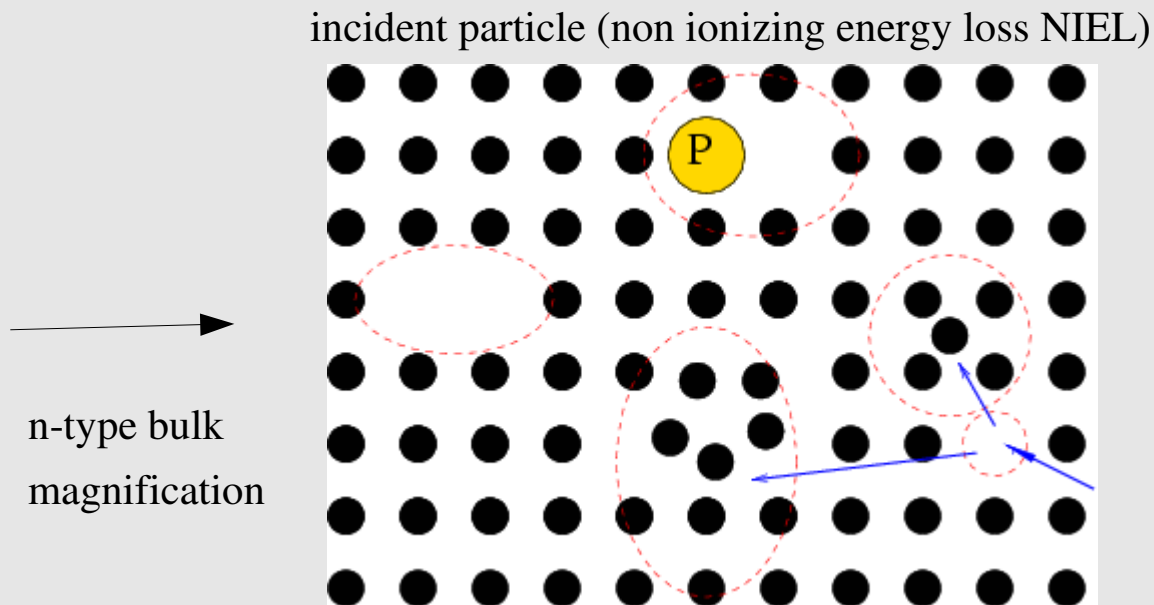
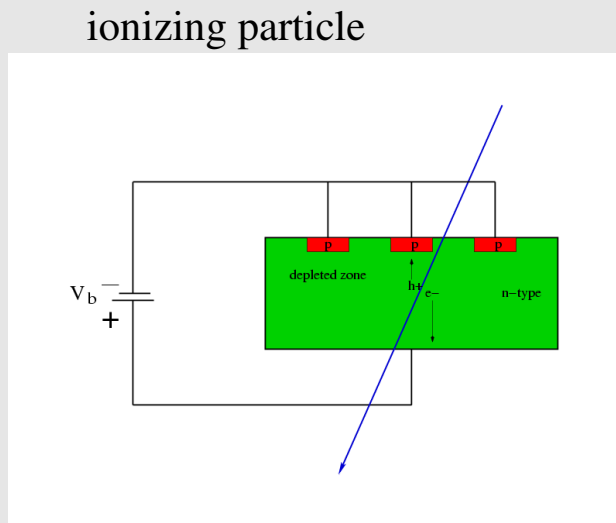

radiation => donor P removal (from + to 0) }  
 radiation => 'acceptor' creation (from 0 to -) } → **n-type inversion:** the effective dopant has changed the space charge from + to - in the depleted zone.

**absorbed radiation => change in time of the depletion voltage => monitoring of the detector needed**

