



Testing temperature measuring system for security and gas self-extinguishing for MPD detector

Author: Patryk Marcola
Supervised by: mgr inż. Marek Peryt



Front of fire protection module



Back of fire protection module

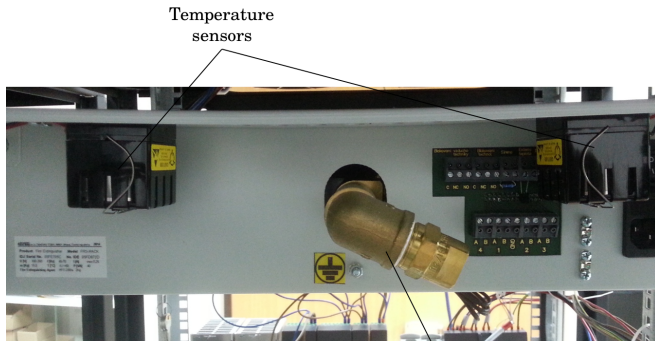

Gas cylinder with
HFC-236fa
refrigerant

HFC-236fa refrigerant

- 1,1,1,3,3,3-Hexafluoropropane
- non-flammable, has low toxicity, and is non-ozone depleting
- works while equipment is still power supplied
- ideally suited for protecting high-value equipment such as in computer rooms, telecommunication facilities, and aircraft

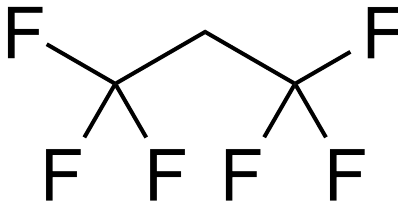

Simplified scheme of measurement stand

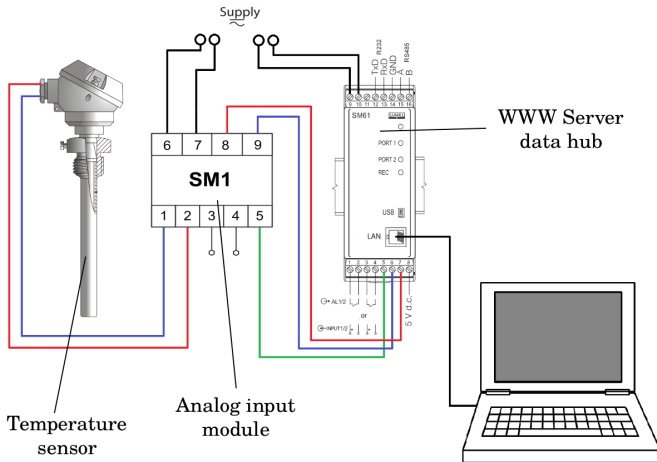

Real photo of measurement stand

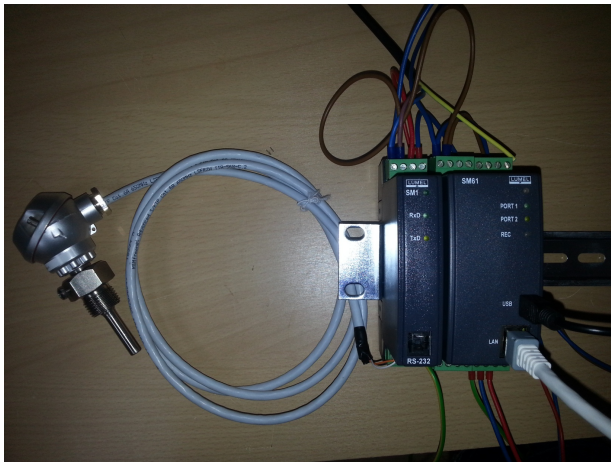

Author: Patryk Marcola Supervised by: mgr inż. Marek Peryt

Testing temperature measuring system for security and gas self-extinguishing for MPD detector

Heating

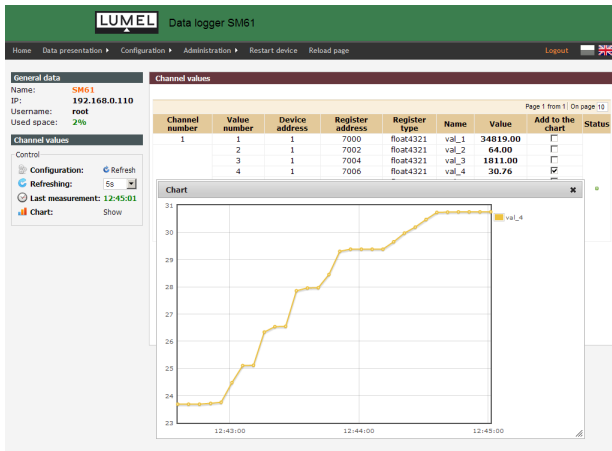

Cooling

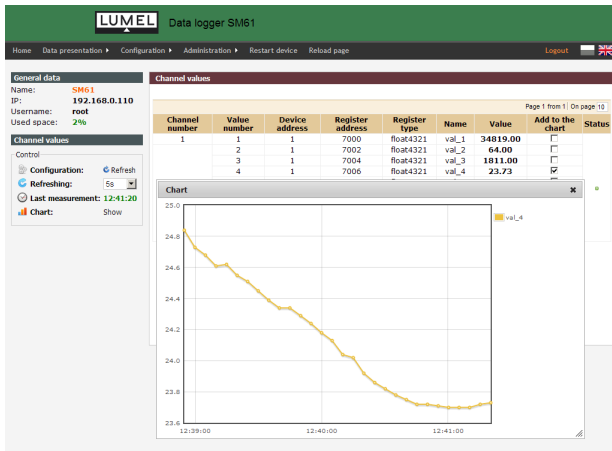

Thank You For Your Attention!

