

Introduction to Linear Colliders

D. Schulte

Collider Choices

- Hadron collisions: compound particles
 - Mix of quarks, anti-quarks and gluons: variety of processes
 - Parton energy spread
 - QCD processes large background sources
 - Hadron collisions \Rightarrow large discovery range
- Lepton collisions: elementary particles
 - Collision process known
 - Well defined energy
 - Other physics background limited
 - Lepton collisions \Rightarrow precision measurements
- Lepton-hadron is also possible

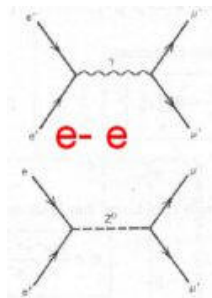
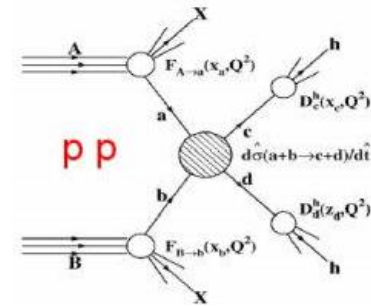

Past/Existing High Energy Frontier Colliders

Only referring to the highest energy

Lepton colliders:

- **LEP** (Large Electron Positron Colliders)
 - Z_0 factory at 90GeV electron-positron cms energy
 - W^+W^- factory at 160GeV
 - Above 200GeV for higgs search
 - Closed in
- **SLC** (Stanford Linear Collider)
 - Z_0 factory at 90GeV electron-positron cms energy

Hadron colliders

- **LHC** (Large Hadron Collider):
 - Proton-proton with 13TeV
 - Ion-ion operation
 - Still operating

Considered Future High Energy Frontier Colliders

Circular colliders:

- **FCC** (Future Circular Collider)
 - FCC-hh: 100TeV proton-proton cms energy, ion operation possible
 - FCC-ee: Potential intermediate step 90-350 GeV lepton collider
 - FCC-he: Lepton-hadron option
- **CEPC / SppC** (Circular Electron-positron Collider/Super Proton-proton Collider)
 - CepC : e^+e^- 240GeV cms
 - SppC : pp 70TeV cms

Linear colliders

- **ILC** (International Linear Collider): e^+e^- , 500 GeV cms energy, Japan considers hosting project
- **CLIC** (Compact Linear Collider): e^+e^- , 380GeV-3TeV cms energy, CERN hosts collaboration

Mentioned

- Muon collider, has been supported in the US but effort strongly reduced
- Plasma acceleration in linear collider
- Photon-photon collider
- LHeC

LEP (at CERN)

27km circumference

Electron-positron collider

4 experiments: ALEPH, DELPHI, L3, OPAL

CMS energy: 90GeV (LEP I) - 209GeV (LEP II)

Peak Luminosity: $10^{32} \text{cm}^{-2} \text{s}^{-1}$

Operation: 1989-2000

Highest particle speed in any accelerator

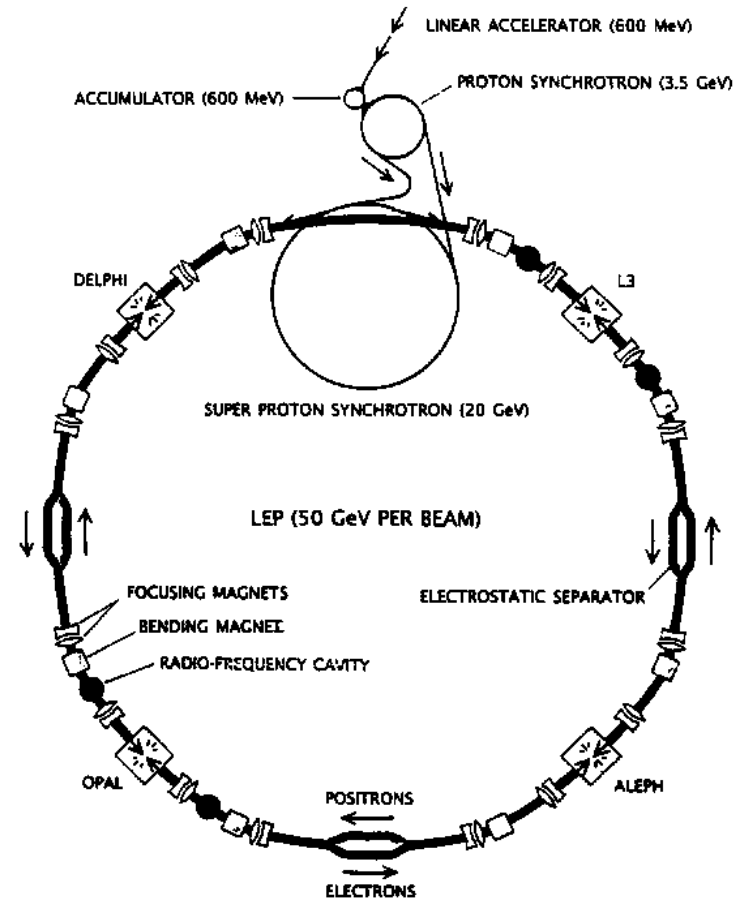

SLC (at SLAC)

Electron-positron linear collider

2 experiments: first MARK II, then SLD

CMS energy: 92GeV

Peak Luminosity: $2 \times 10^{30} \text{cm}^{-2} \text{s}^{-1}$

Operation: 1989-1998

The only linear collider so far

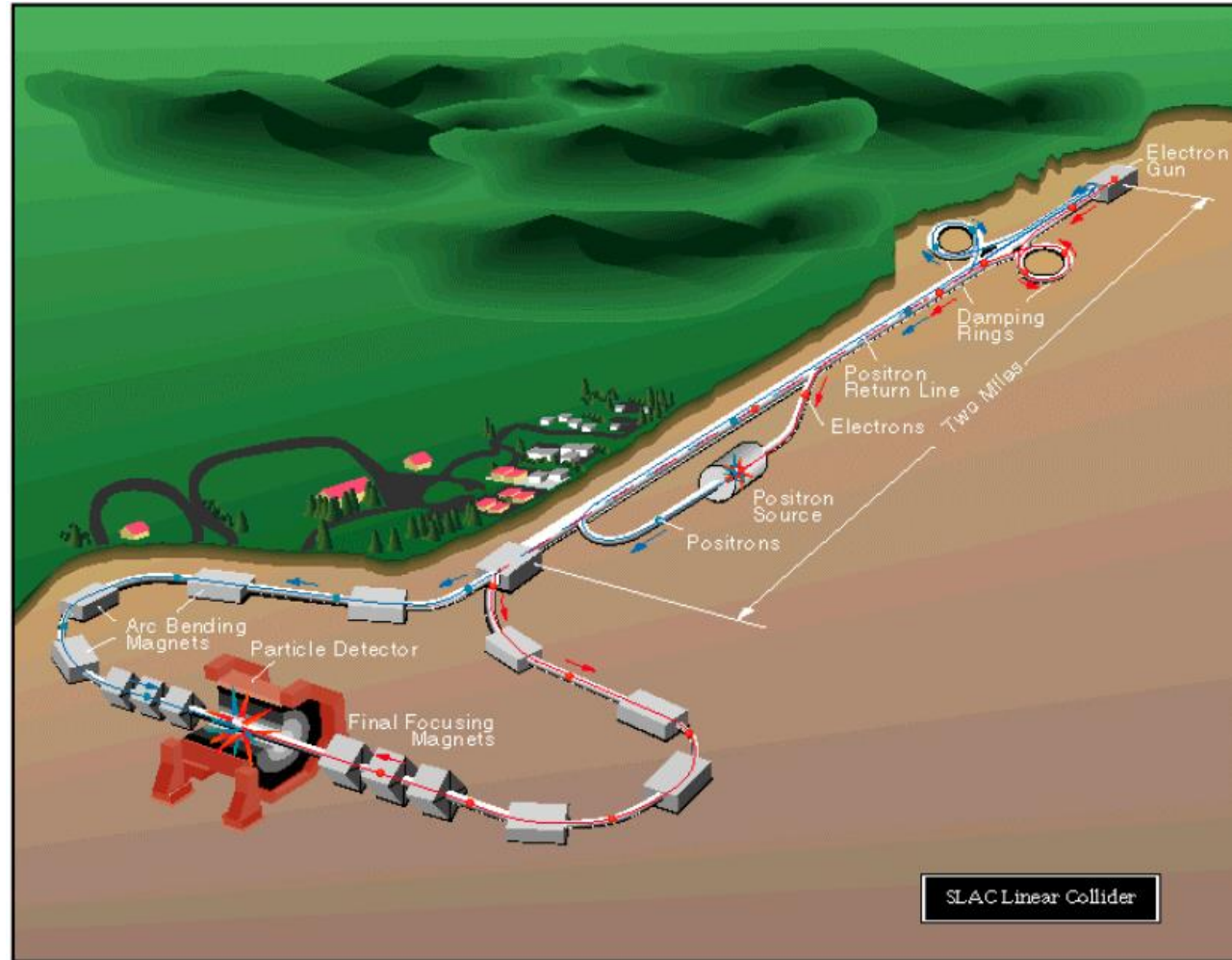

The LHC Experiments

ATLAS

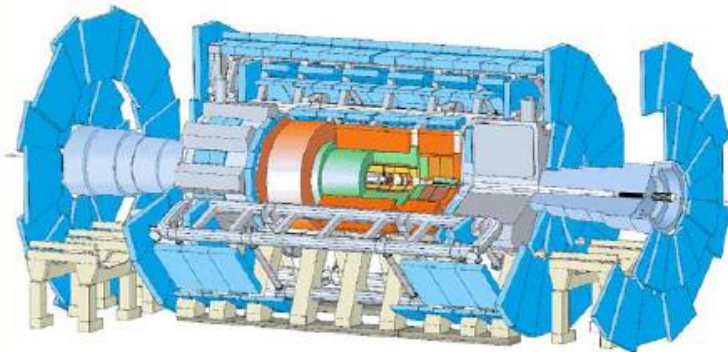

CMS

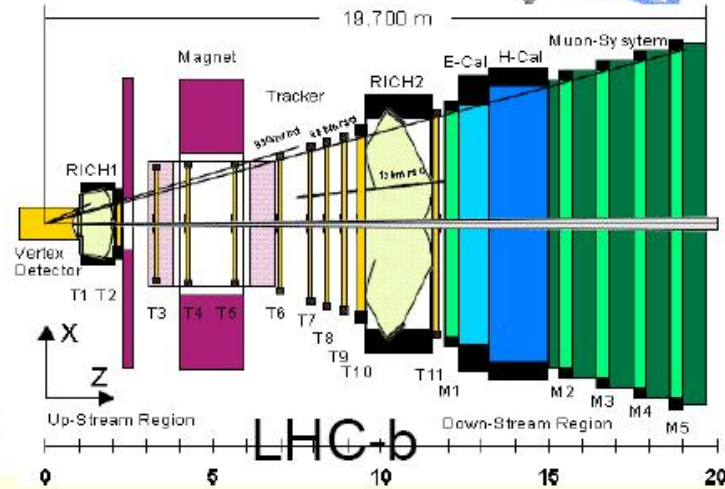
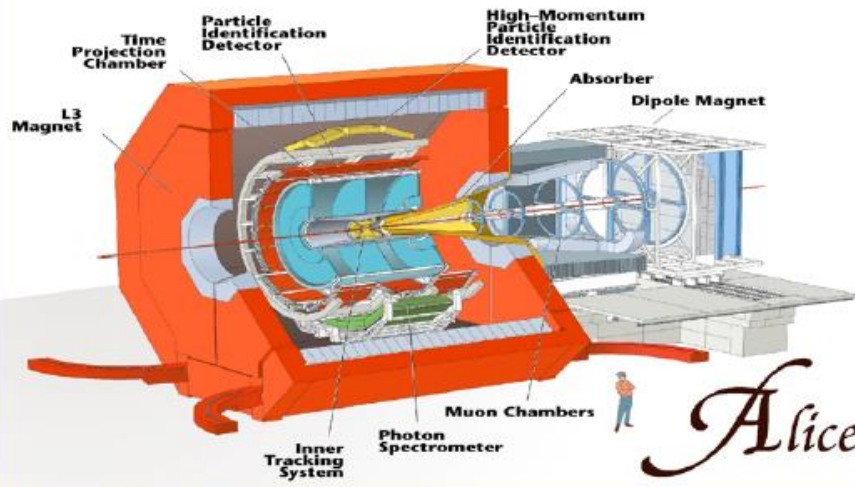
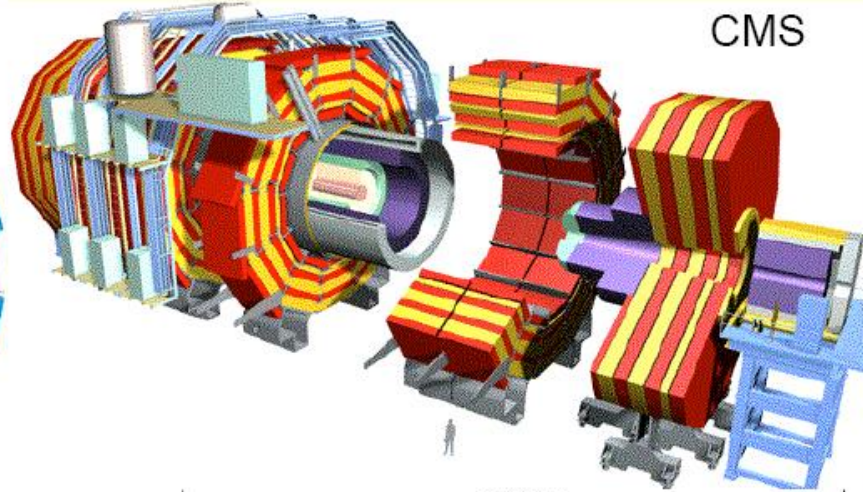

Higgs Discovery

July 4, 2012

A higgs-like particle has been found in ATLAS and CMS

⇒ Nobelprize in 2013 to François Englert and Peter W. Higgs

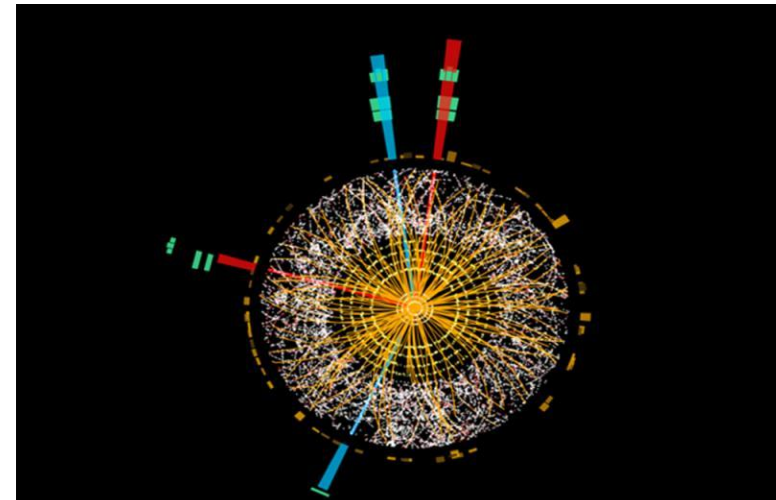
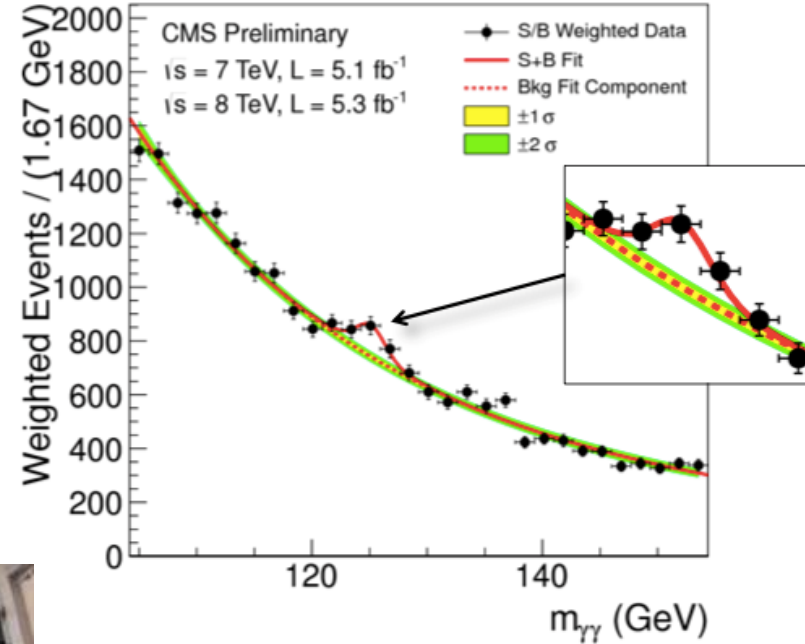

LHC schedule beyond LS1

LS2 starting in 2018 (July) => 18 months + 3 months BC
 LS3 LHC: starting in 2023 => 30 months + 3 months BC
 Injectors: in 2024 => 13 months + 3 months BC

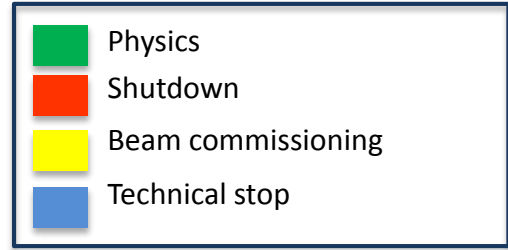

30 fb⁻¹

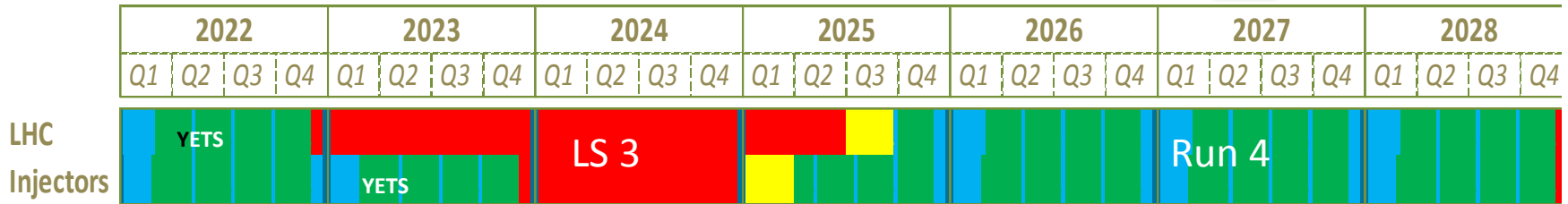
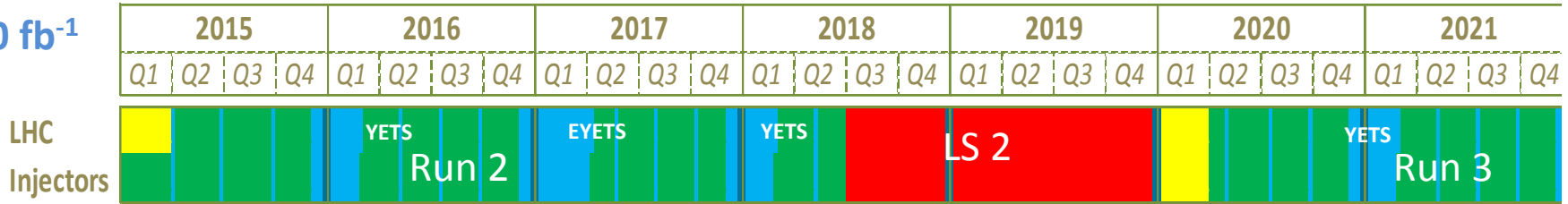

300 fb⁻¹

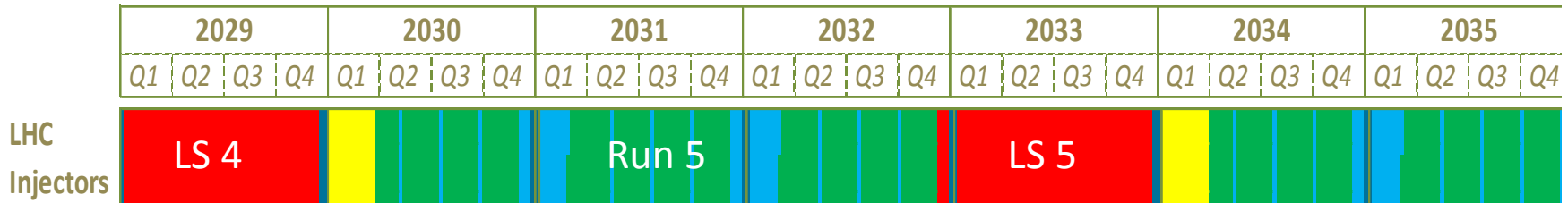

(Extended) Year End Technical Stop: (E)YETS

F. Bordry

3'000 fb⁻¹

The HL-LHC Project

Goal is to obtain about 3 - 4 fb⁻¹/day (250 to 300 fb⁻¹/year)

Many improvements on the injector chain

- Linac 4 - PS booster
- PS
- SPS

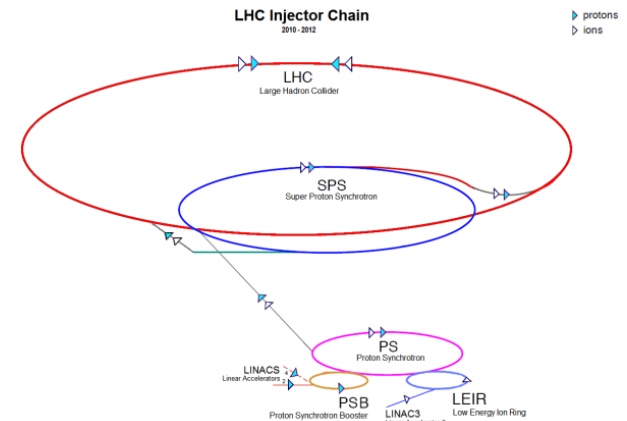
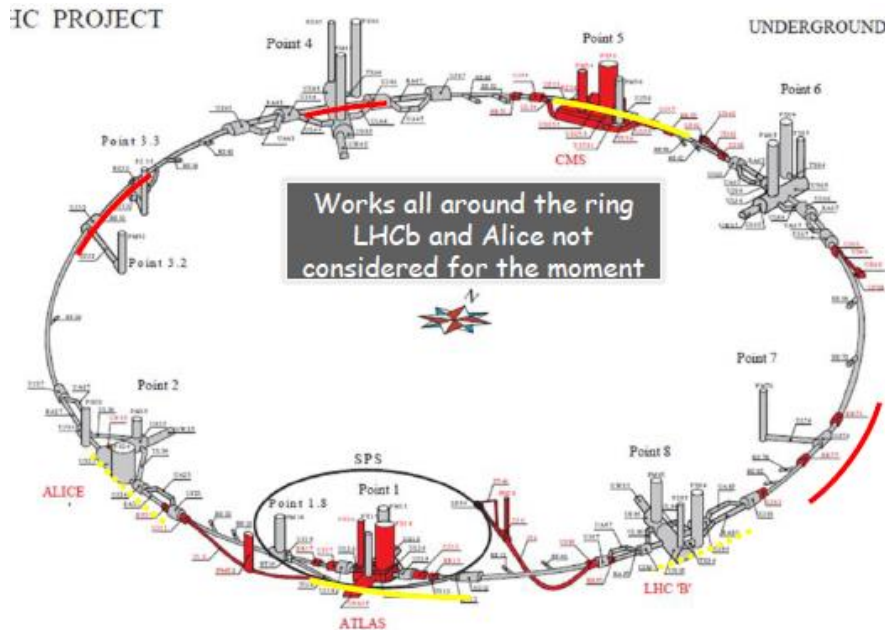

Many improvements on the LHC ring

- New IR-quads Nb₃Sn (inner triplets)
- New 11 T Nb₃Sn (short) dipoles
- Collimation upgrade
- Cryogenics upgrade
- Crab Cavities
- Cold powering
- Machine protection
- ...

Example of International Collaboration

F. Bordry

Baseline layout of HL-LHC IR region

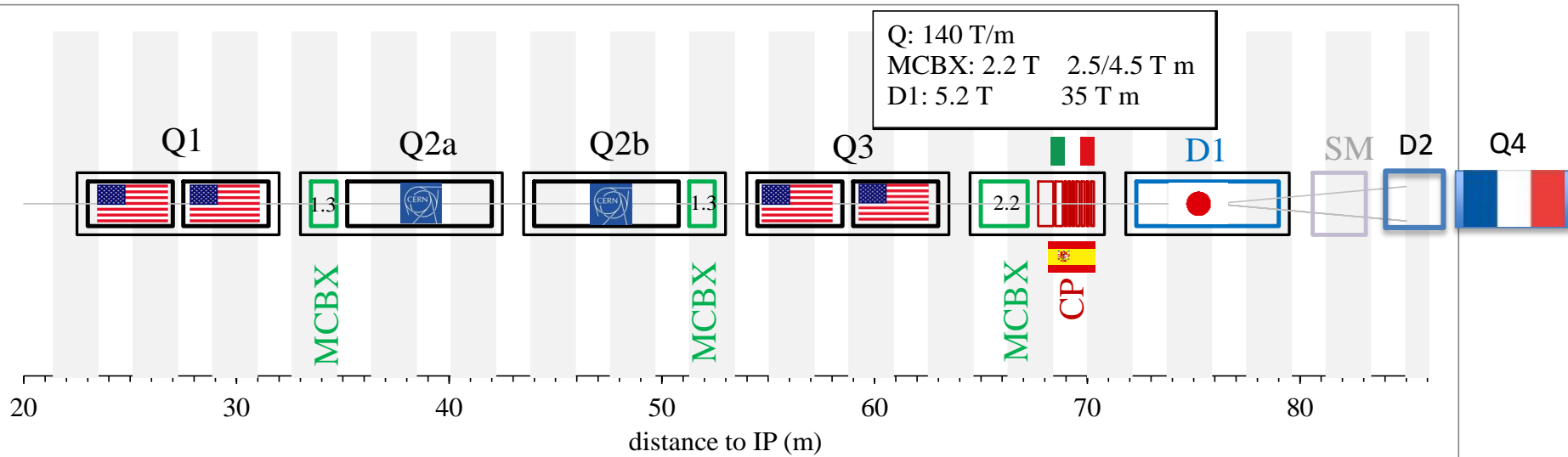

with national laboratories but also involving industrial firms

Other Colliders

PEP-II, SLAC, Palo Alto, USA

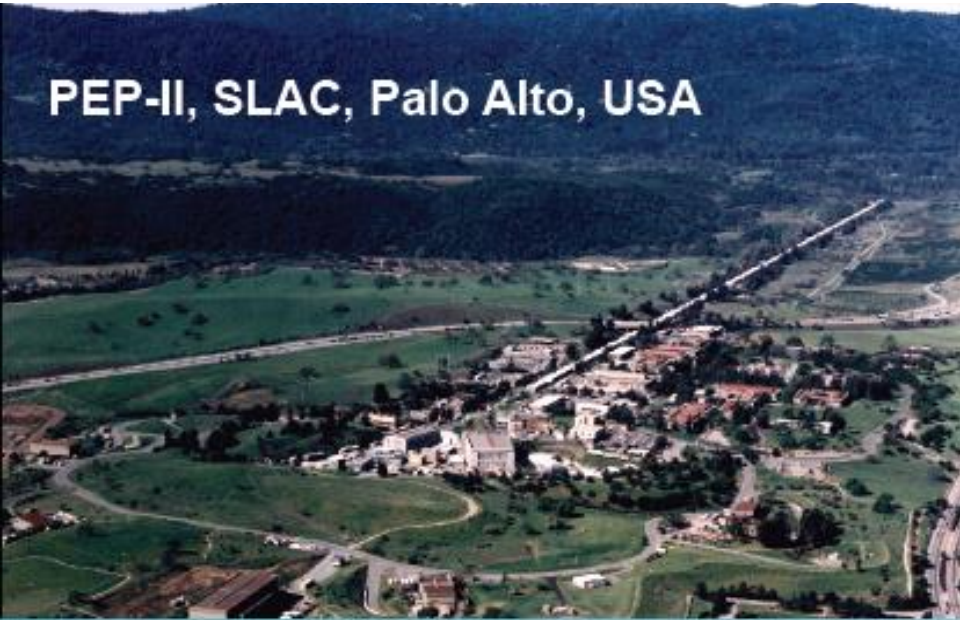

KEKb, KEK, Tsukuba, Japan



HERA, DESY, Hamburg, Germany



Tevatron, Fermilab, Chicago, USA



Lepton Collider Physics

Higgs Physics in e+e- Collisions

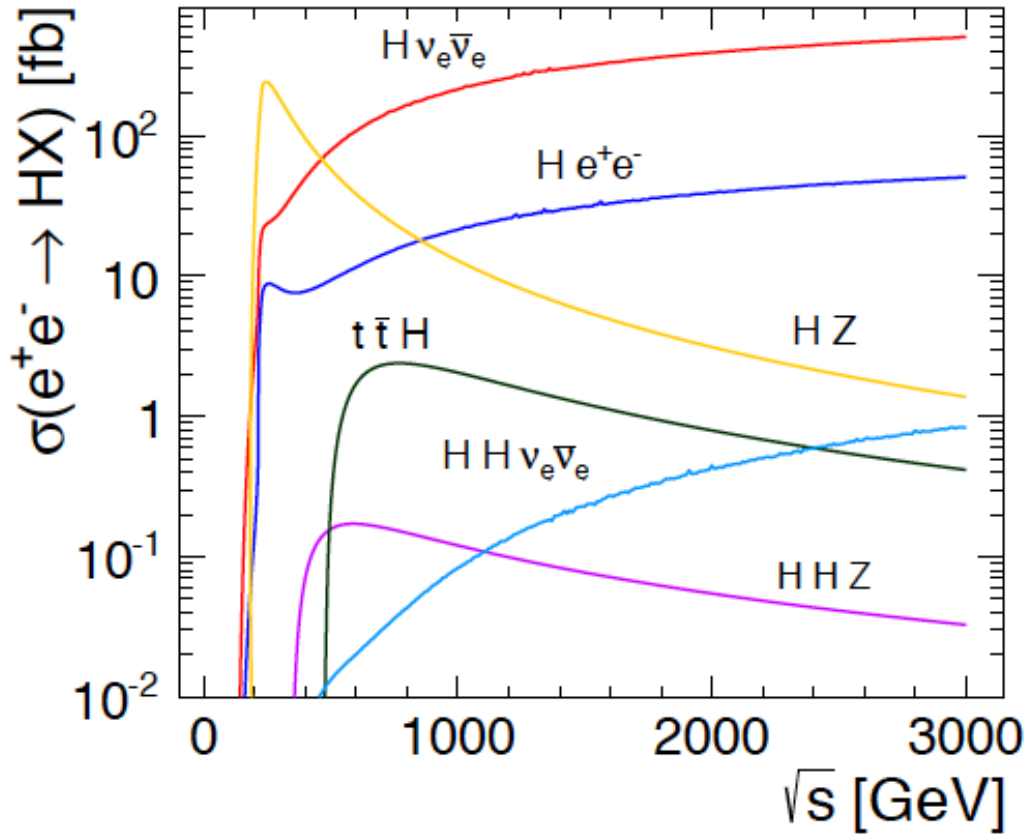

- **Precision Higgs measurements**
- Model-independent
 - Higgs couplings
 - Higgs mass
- Large energy span of linear colliders allows to collect a maximum of information:
 - ILC: 500 GeV (1 TeV)
 - CLIC: ~350 GeV – 3 TeV

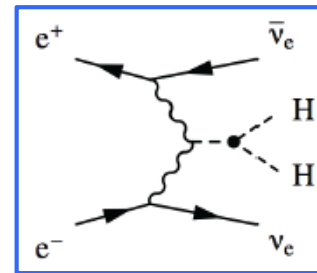
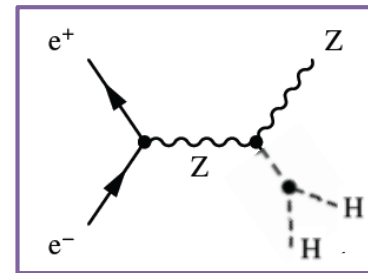
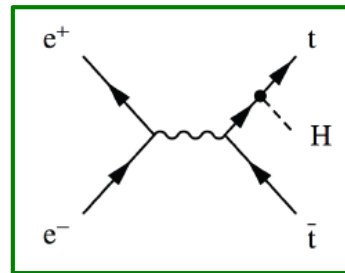
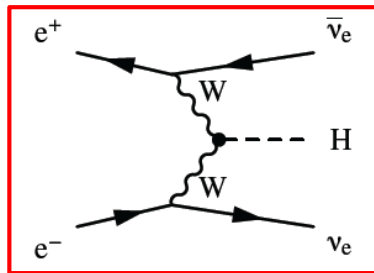
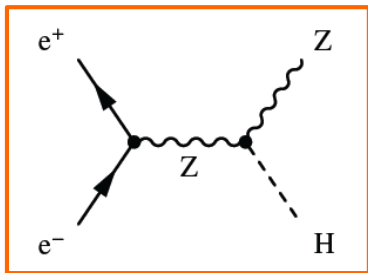

Higgs Branching Ratios

An important verification of the higgs model

Predict that higgs decay rates depend on particle masses

Maximum cross section around 250GeV

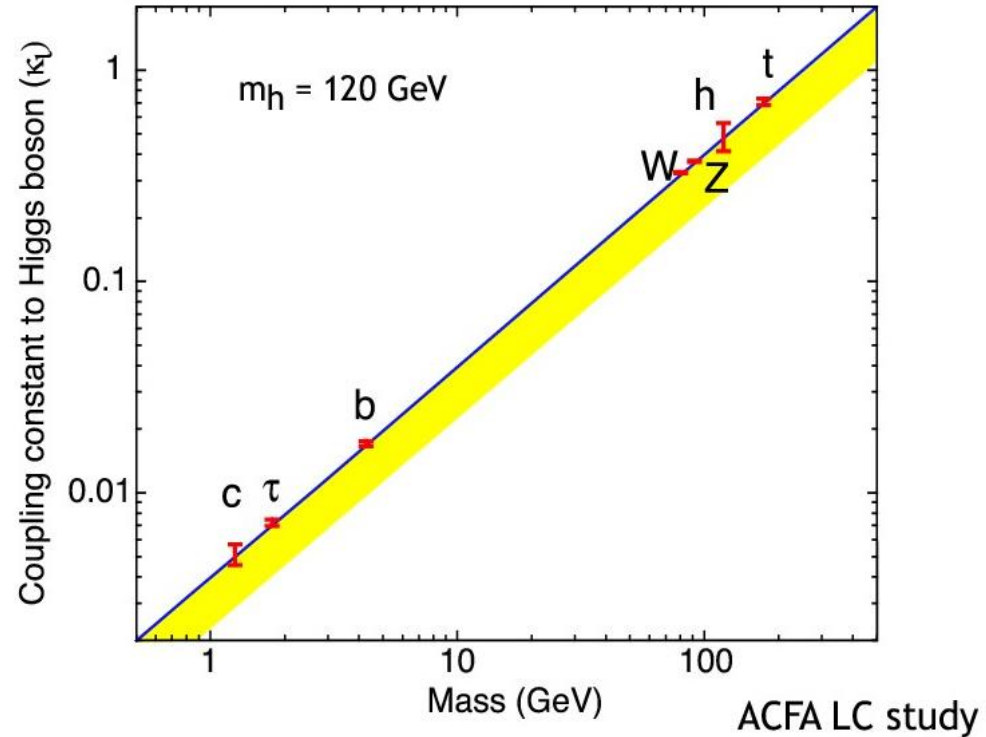
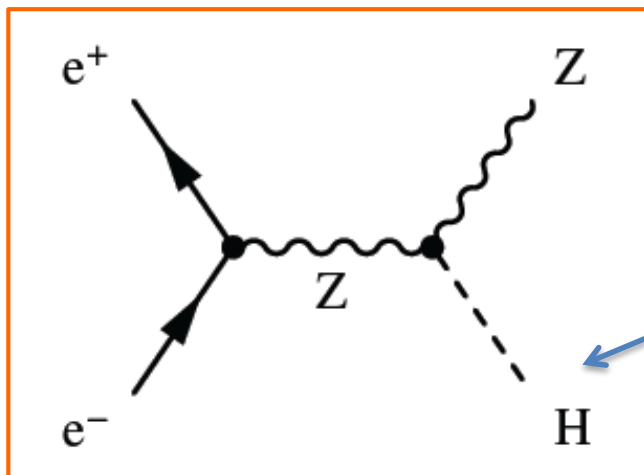

Measure decay products of the higgs

Invisible Higgs Decays

Can we check that the Higgs does not decay into something invisible, e.g. neutrinos?

Yes, missing mass (or recoil mass) analysis:

1) Measure the Z, e.g. from produced jets

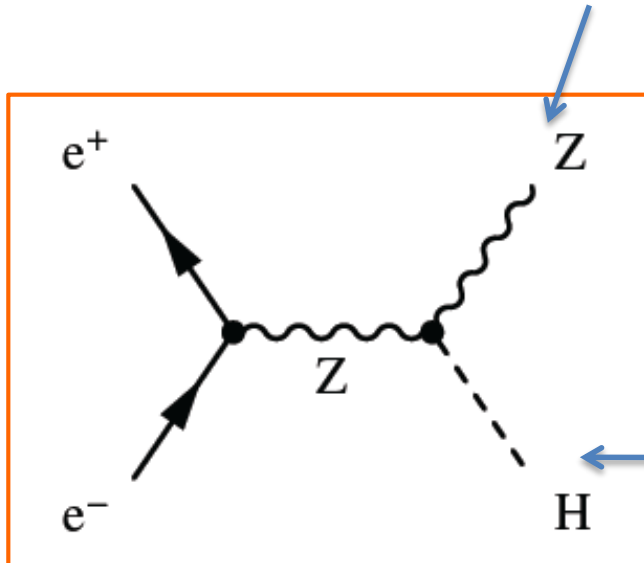

2) Subtract Z momentum from initial state

$$(E_{\text{cm}}, 0, 0, 0) - (E_Z, P_{Z,x}, P_{Z,y}, P_{Z,z}) = (E_H, P_{H,x}, P_{H,y}, P_{H,z})$$

3) Result is mass and momentum of other particle
Even if we do not see it

So we know the missing particle

Example Result

Not everything that has the mass of a higgs is a higgs

Actual higgses

Other things that look like higgses

Predicted signal

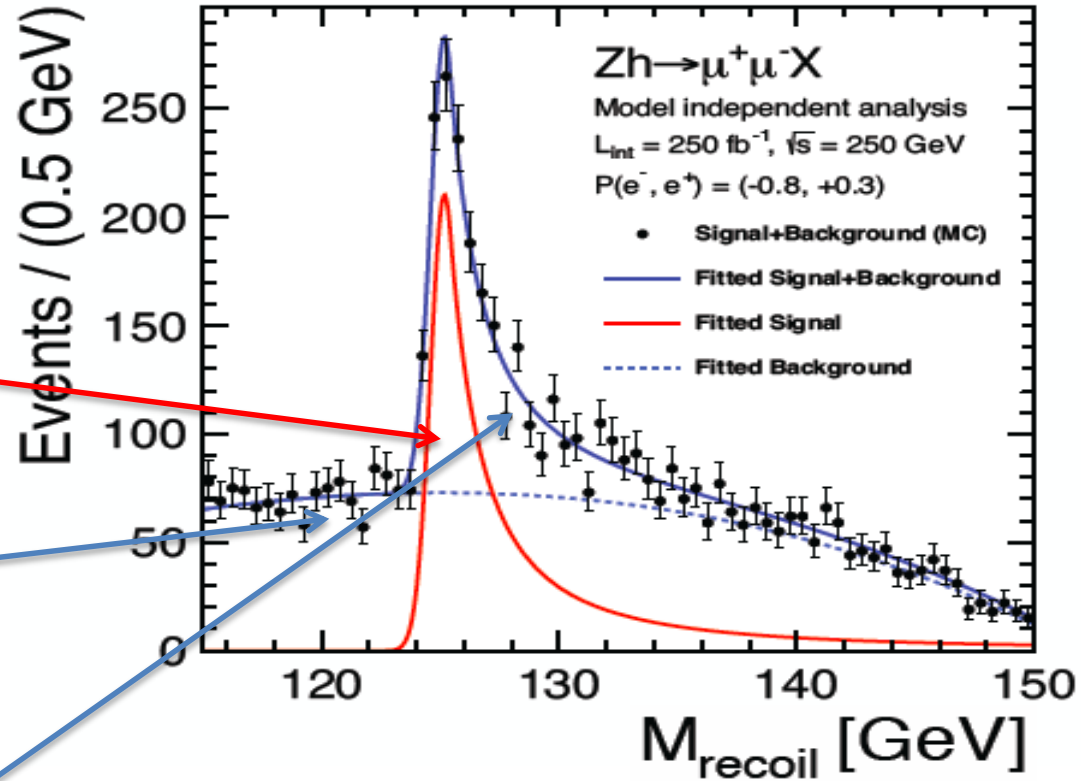

Accurate mass measurement
best near 250 GeV
 $\Delta m_H \approx 30 \text{ MeV}$

Higgs Branching Ratios

Quick calculation:

Higgs mass 125 GeV

W mass 80 GeV

⇒ A higgs cannot not decay into two W?

Well it can if one of the W has a too low mass (is virtual)

But nature does not allow that too often

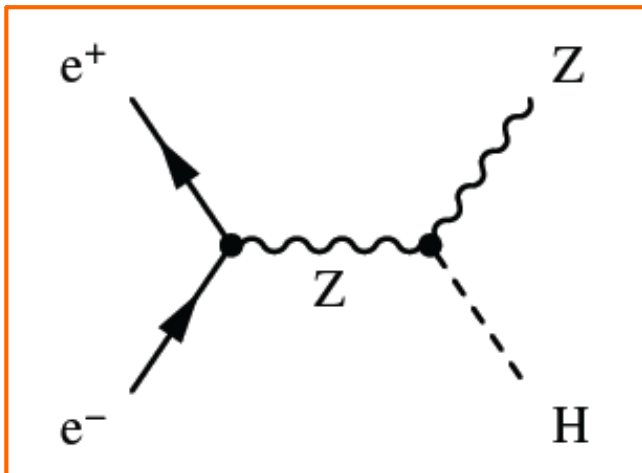
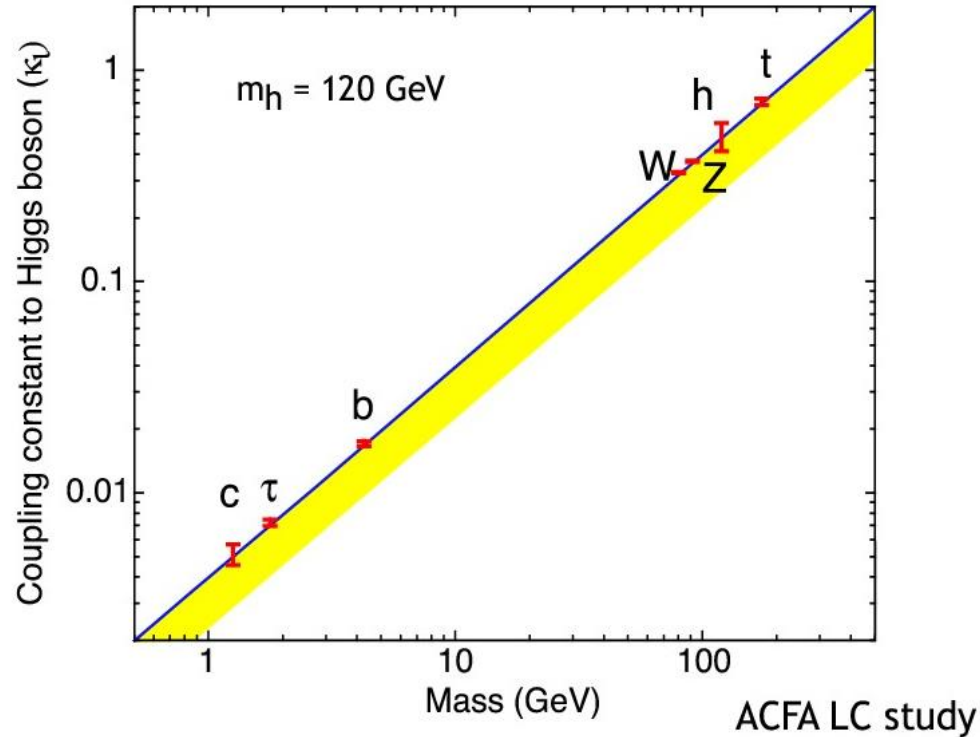

⇒ Higgs will not decay very often into WW or tt pairs

⇒ The coupling measurement is not very good

Higgs Coupling to W and Top

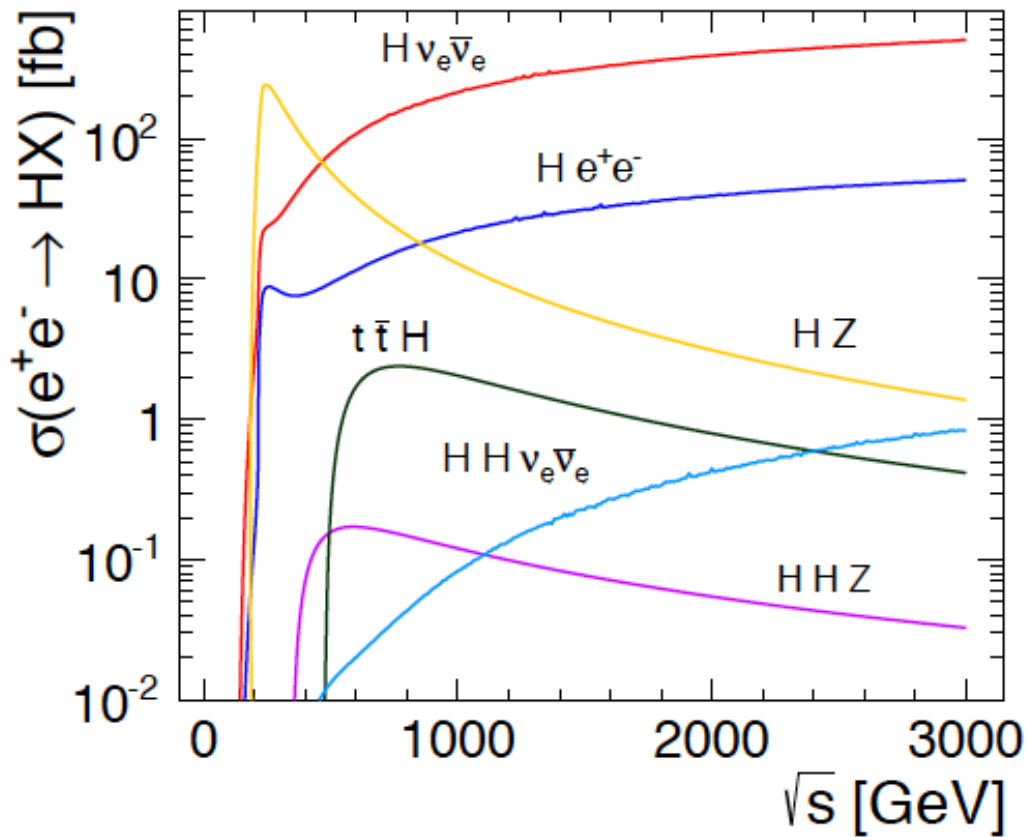

- **Precision Higgs measurements**
- Model-independent
 - Higgs couplings
 - Higgs mass
- Large energy span of linear colliders allows to collect a maximum of information:
 - ILC: 500 GeV (1 TeV)
 - CLIC: ~ 350 GeV – 3 TeV

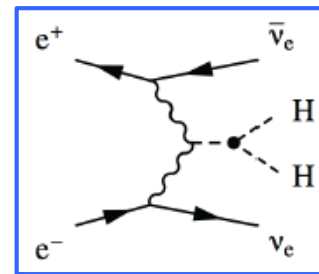
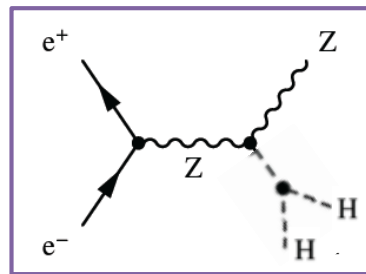
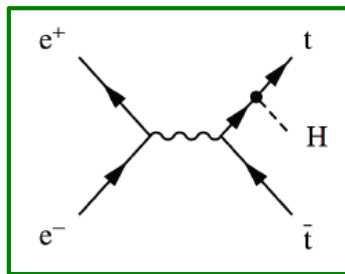
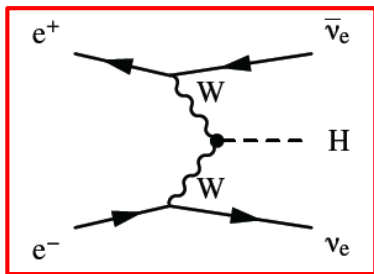
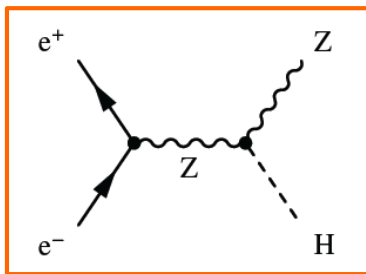

Combined Higgs results (ILC)

Projected Higgs Coupling Precision, Model-Independent Fit

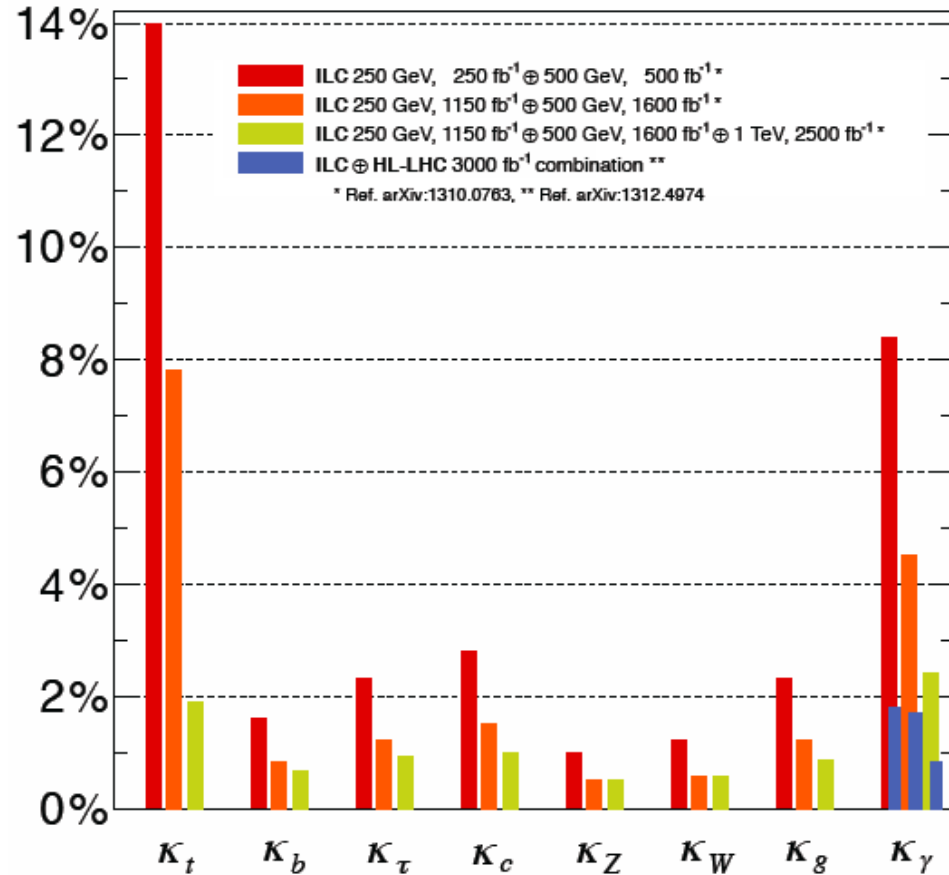

Fully model-independent

Projected Higgs Coupling Precision, Model-Dependent Fit

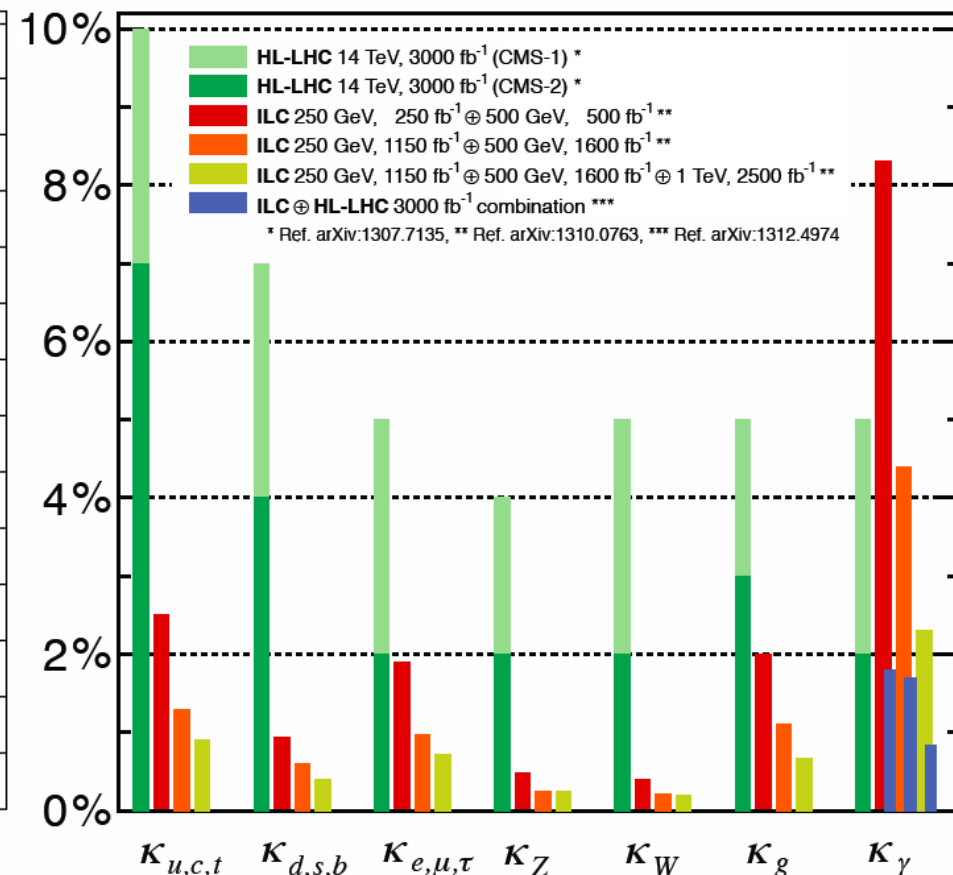

LHC-like fits, assuming SM decay modes only

Double Higgs – and CLIC Higgs summary

Higgs self-coupling.

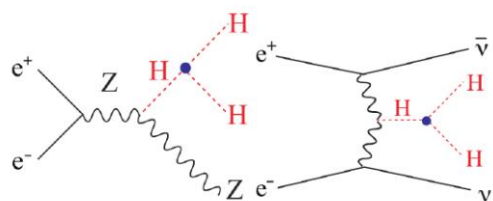

- Difficult measurement due to very
- Sensitivity much improved at 1 TeV
 - ★ Contributions from background di smaller than for $e^+e^- \rightarrow ZHH$

\sqrt{s} (GeV)	500	500
L (fb ⁻¹)	500	1600
$\Delta\lambda/\lambda$	83%	46%

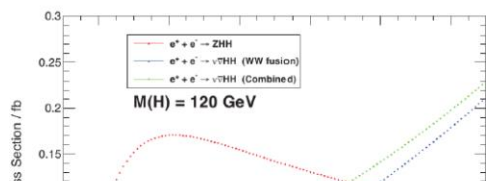

From talk of Kerstin Tackmann (Higgs – decays and properties) in ICFA seminar 2014

Going to higher energies.

- CLIC offers possibility to go to higher energies

\sqrt{s}	350-375 GeV	1.4 TeV	3 TeV
L	500 fb ⁻¹	1.5 ab ⁻¹	2 ab ⁻¹

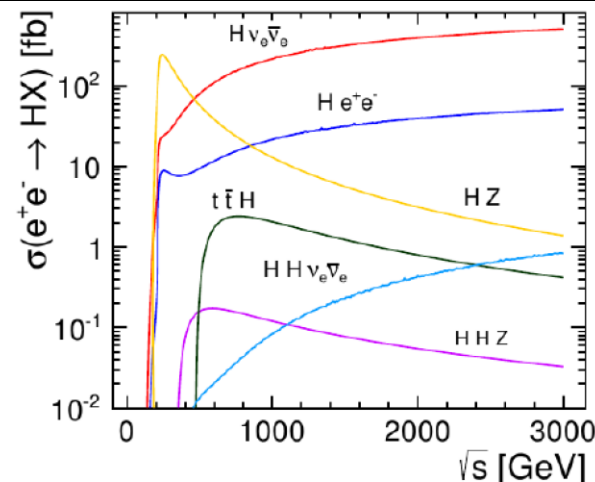

- %-level uncertainties for coupling measurements

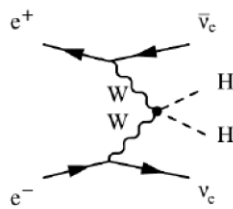

- Improved sensitivity for rare decays

Measurement	Observable	Statistical precision	
		1.4 TeV 1.5 ab ⁻¹	3.0 TeV 2.0 ab ⁻¹
$\sigma(HH\nu_e\nu_e)$	g_{HHWW}	7% (prel.)	3% (prel.)
$\sigma(HH\nu_e\nu_e)$	λ	32%	16%
with 80% e^- polarisation	λ	24%	12%

coupling relative to SM

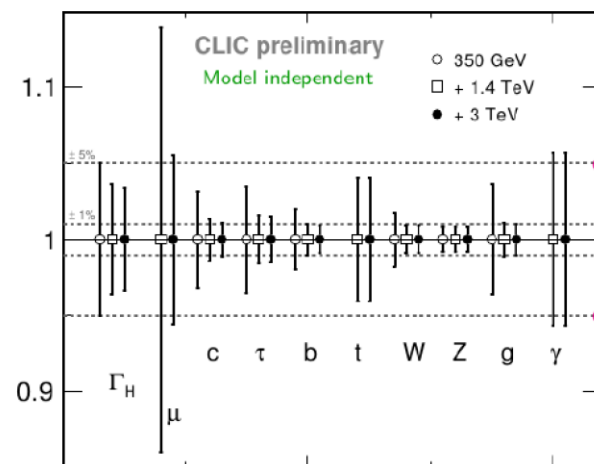

Top Production at Threshold

K. Seidel et al. arXiv:1303.3758

Top production at threshold is strongly affected by beam energy spread and beamstrahlung

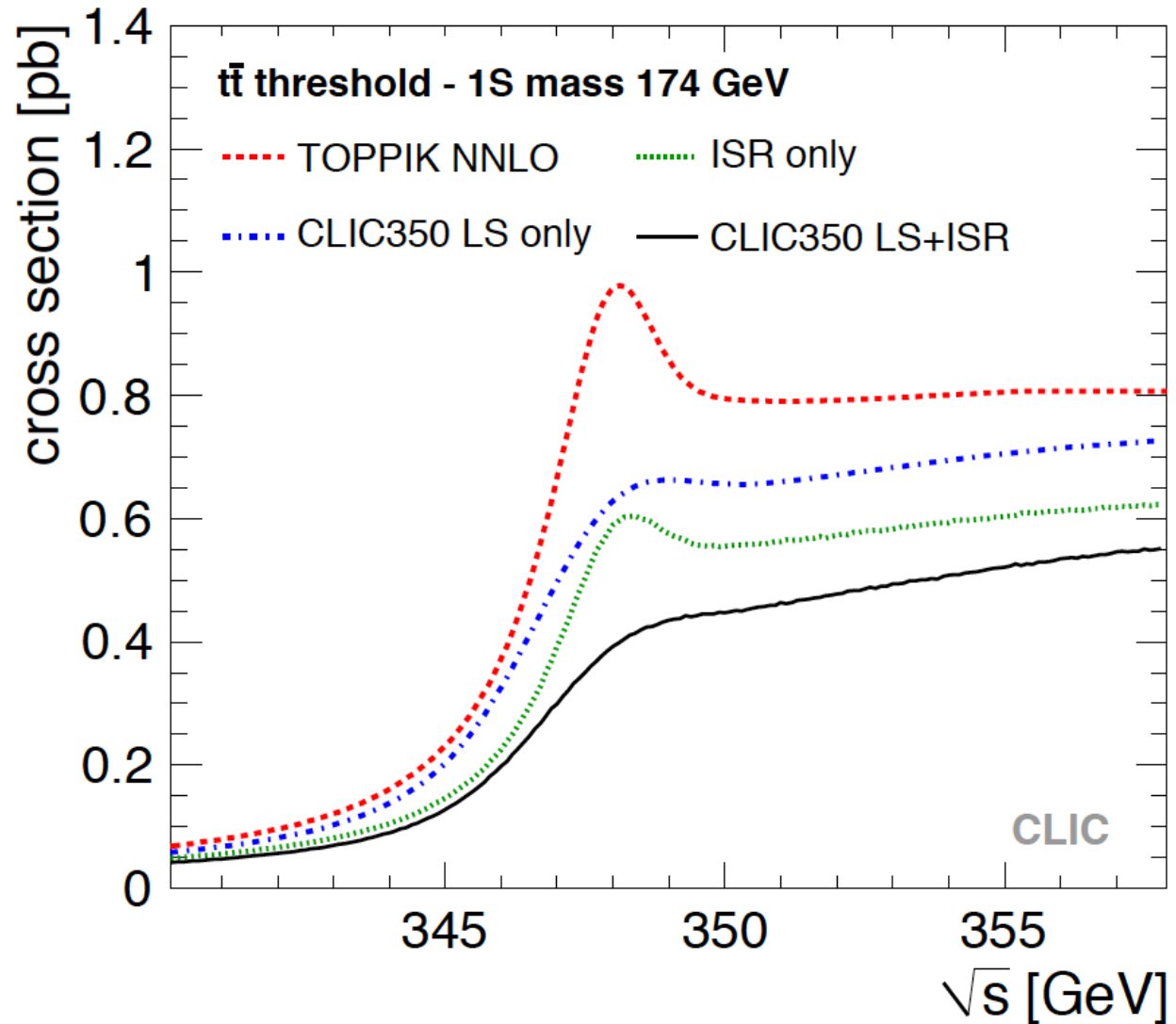

Top Production at Threshold

Experimental precision makes the theorists sweat

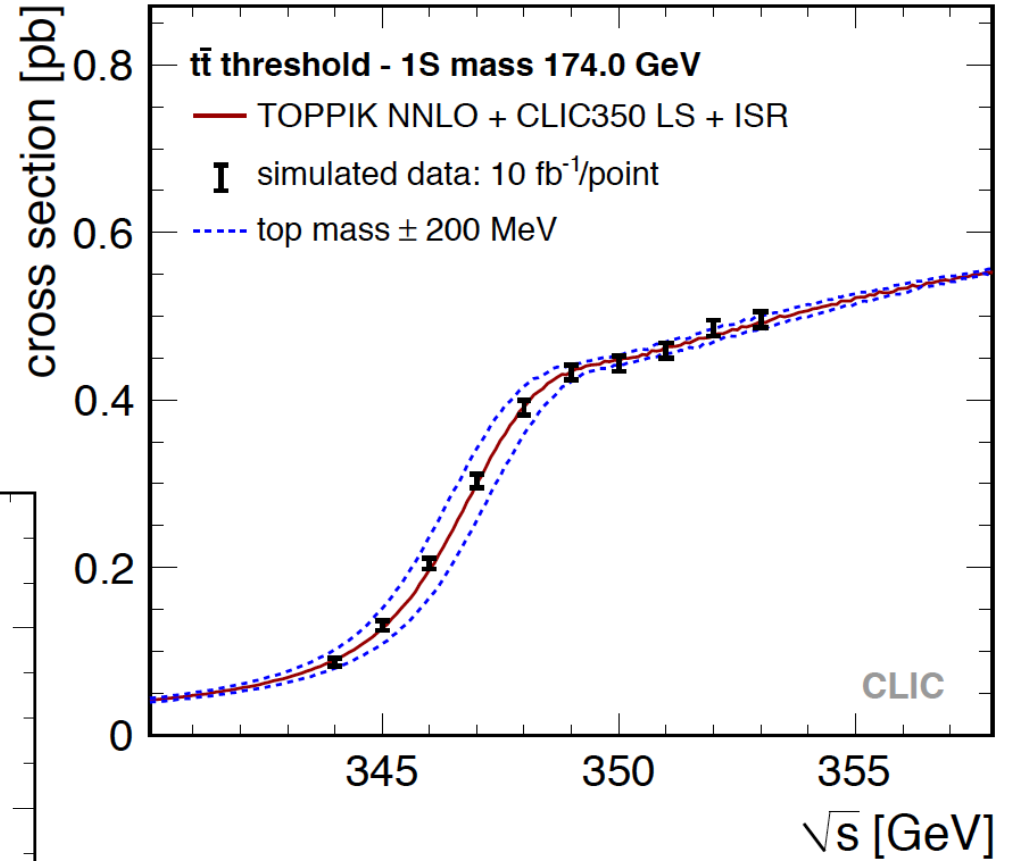

Very precise measurements

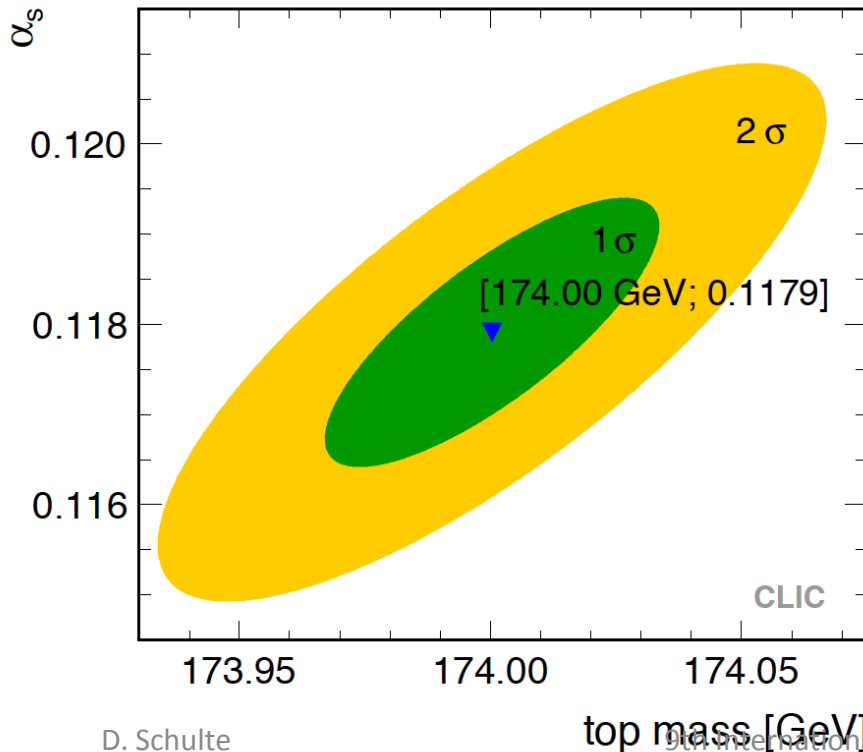

Top Physics

Top quark in the SM, heaviest elementary particle:

- Many high-precision measurements possible in e^+e^- (like for s, c quarks) – some examples

Accurate coupling measurement from:

- $t\bar{t}$ cross section
- Helicity
- Forward-backward asymmetry F_{AB}

ILC study at 500 GeV and 500 fb^{-1}

Provides good sensitivity to BSM physics

Sensitivity to BMS increases with energy

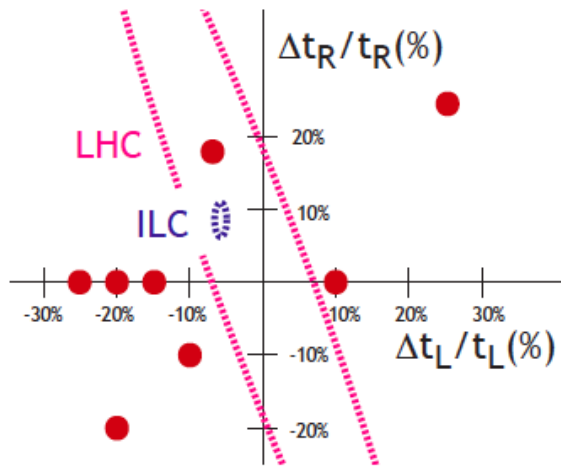

Note: LHC comparisons not recent (Snowmass 2005)

Accuracy of left-handed and right-handed top couplings, together with deviations from various BSM models ([arXiv:1403.2893](https://arxiv.org/abs/1403.2893))

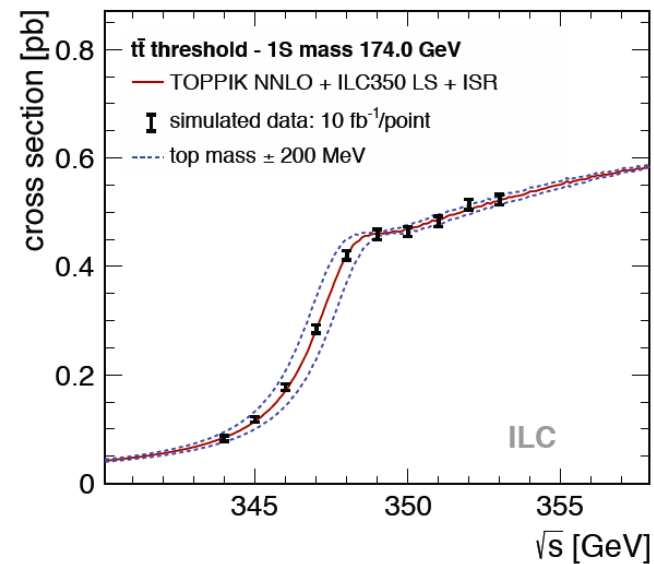

Threshold scan with well-defined 1S mass

Stat. accuracy $\Delta m_t = 20\text{-}30 \text{ MeV}$ (ILC-CLIC)

Theor. accuracy currently $\Delta m_t = 100 \text{ MeV}$

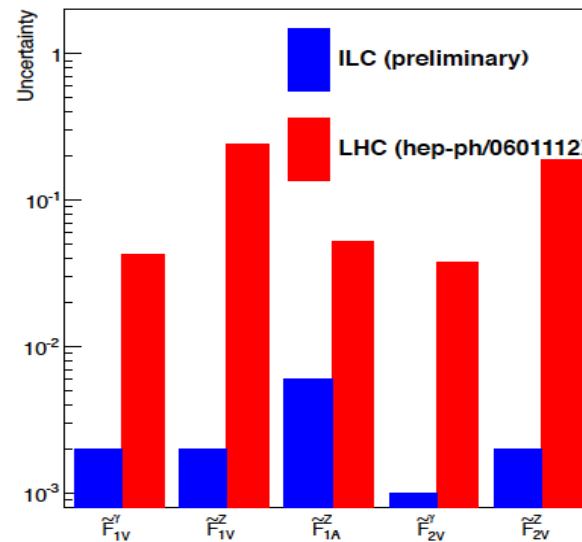

arXiv:1307.8
102

Figure 11: Comparison of statistical precisions on CP conserving form factors expected at the LHC, taken from [3] and at the ILC. The LHC results assume an integrated luminosity of $\mathcal{L} = 300 \text{ fb}^{-1}$. The results for ILC assume an integrated luminosity of $\mathcal{L} = 500 \text{ fb}^{-1}$ at $\sqrt{s} = 500 \text{ GeV}$ and a beam polarisation $P = \pm 0.8, P' = \mp 0.3$.

Physics Beyond the Standard Model

Hard to know what to expect

But we know that the standard model is not the hole truth

Will not go all the different options

Example: Dark Matter

The outer region of galaxies rotate faster than expected from visible matter

$$v_{circ} = \sqrt{\frac{GM(r)}{r}}$$

Corbelli & Salucci (2000);
Bergstrom (2000)

Dark matter would explain this

Other observations exist
• But all through gravity

What is it?

One explanation is supersymmetry

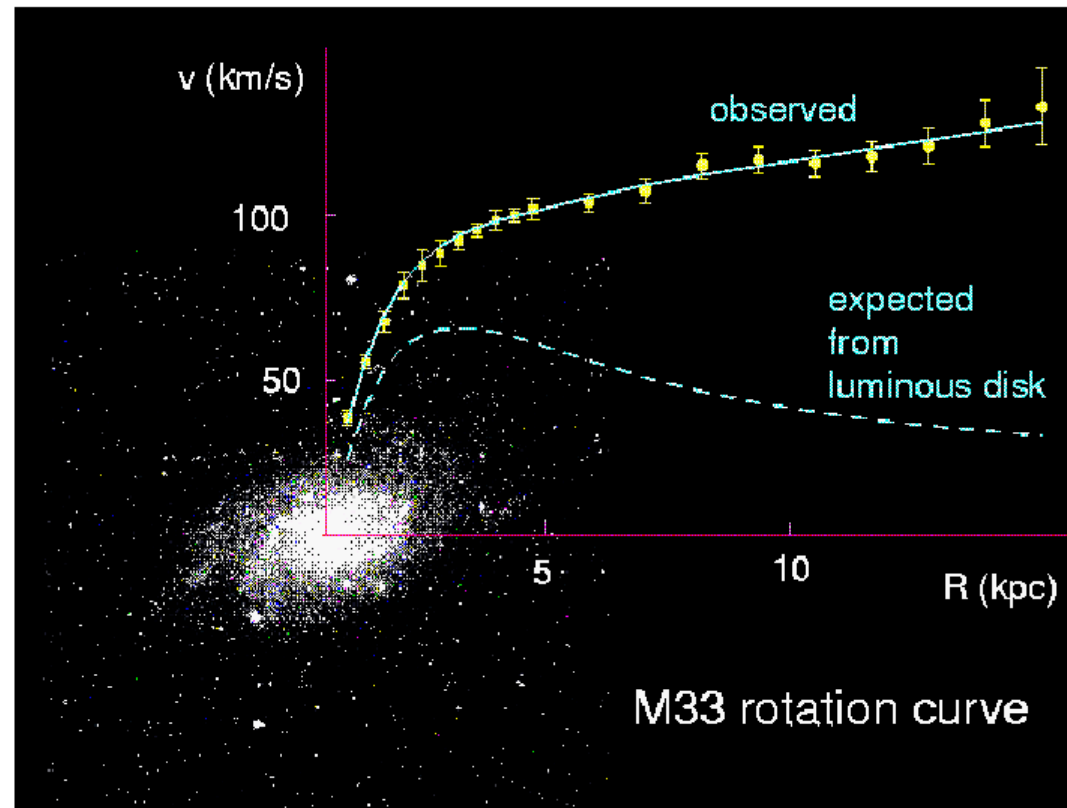

Supersymmetry

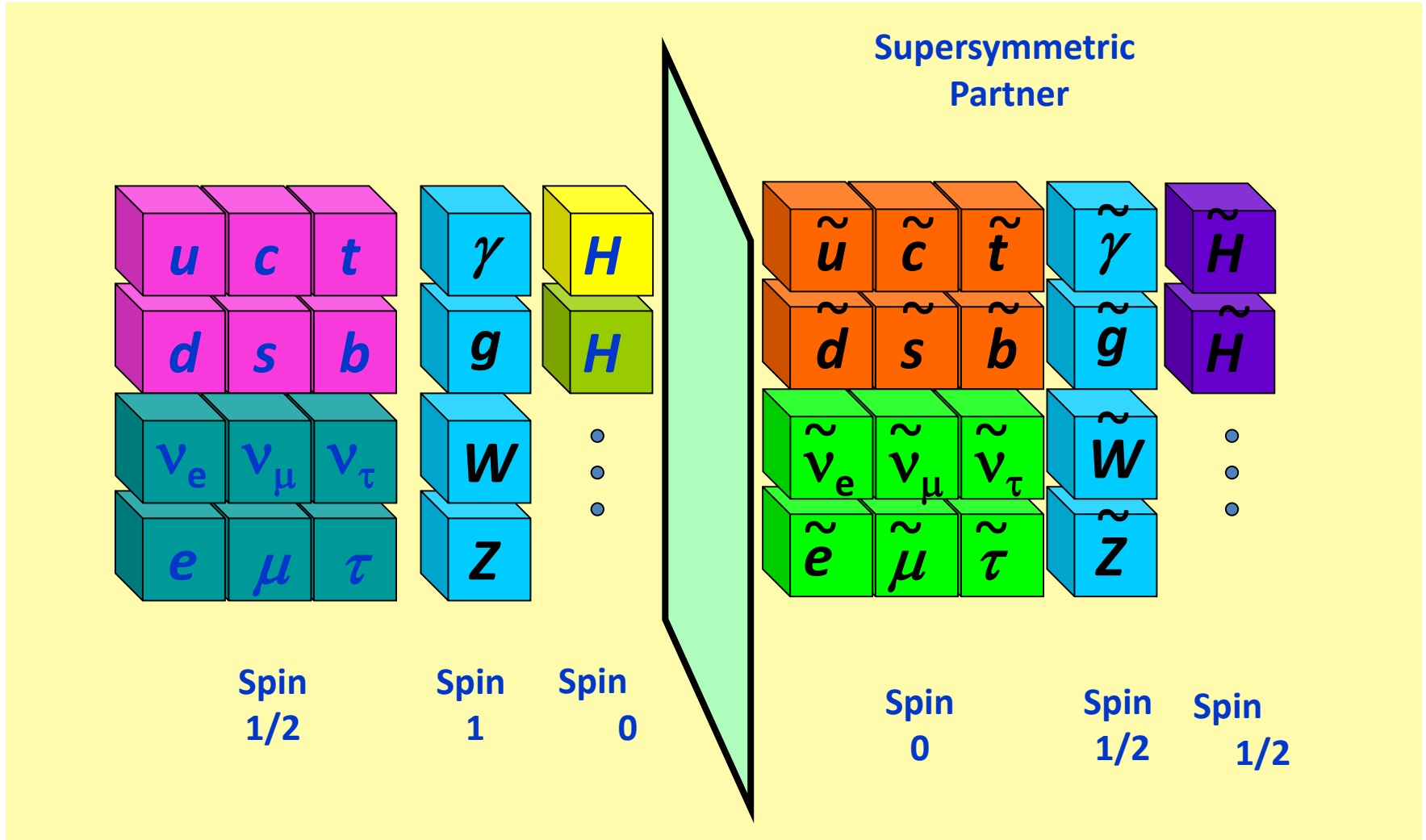

Example of Potential SUSY Scenario

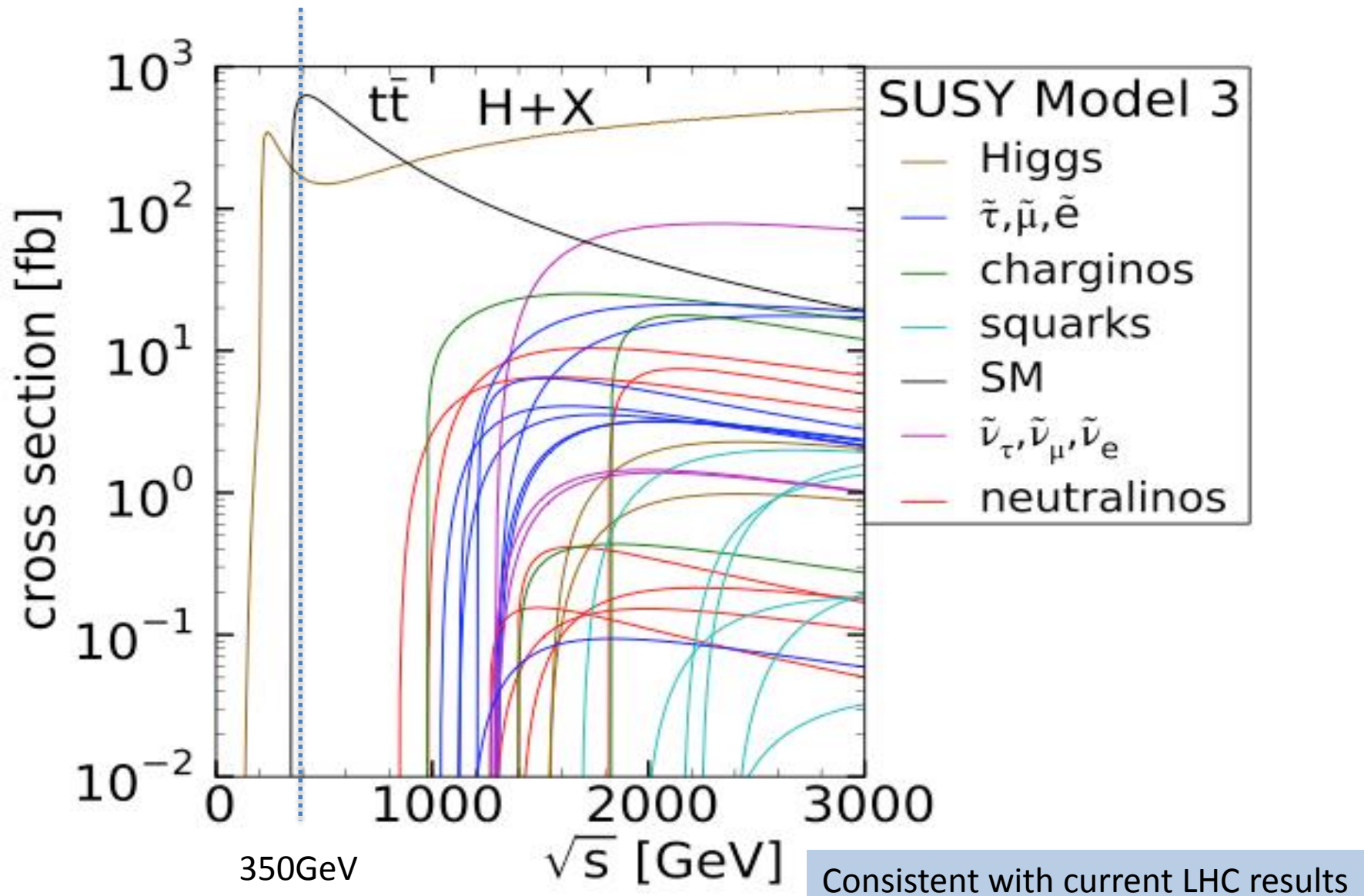

Conclusion on Physics Case

- Lepton colliders offer additional paths to the Higgs
 - Model independent
 - Invisible decays
- Most of the Higgs measurements require at least ~ 350 GeV
- Higher energies to add
 - H_{tt} (500 GeV or slightly above)
 - Higgs-self coupling (even higher energy best)
 - higher energies generally improves the results for rare decays
- Lepton collider offer a unique path to the top at threshold
- Requires around 350 GeV (ttbar threshold at)
- Symmetry measurements suggests 400-500 GeV
- New physics at LHC – who knows ? Most likely the higher energy the better.

Lepton Collider Options

Three main approaches

- Big LEP-type collider ring
 - FCC-ee, CepC
 - Later a proton collider in the same tunnel
- Linear collider
 - ILC, CLIC
 - The focus of this school
- Muon collider

Ring Collider Energy Limitation

Beam can be used many times

Lepton beam energy is below LHC
-> magnets are not a problem

But synchrotron radiation is:

$$\Delta E \propto \left(\frac{E}{m}\right)^4 \frac{1}{R}$$

At LEP2 lost 2.75GeV/turn for E=105GeV

Pay for installed voltage (ΔE) and size (R),
so scale as:

$$R \propto E^2$$

$$\Rightarrow \Delta E \propto E^4 / E^2$$

$$\Rightarrow \Delta E \propto E^2$$

$$\Rightarrow \Delta E \propto R$$

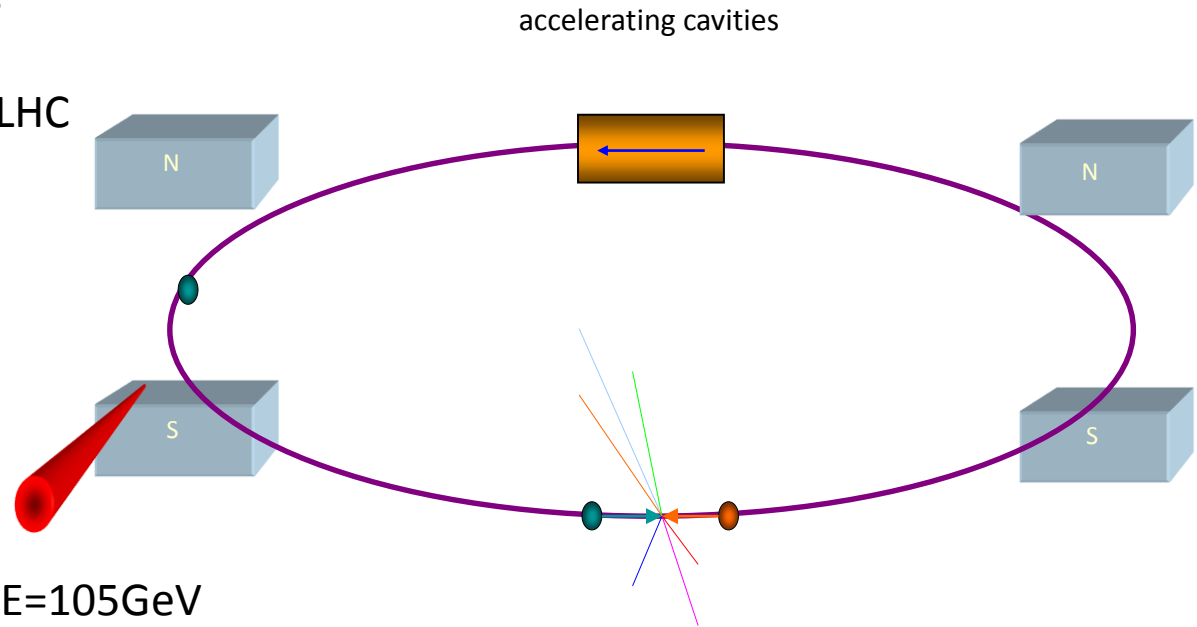

$$C_R = a_R E^2 + b_R$$

-> use heavier particles, e.g. muons
-> or linear collider
(-> or try to push a bit harder on cost)

Linear Collider Energy Limitation

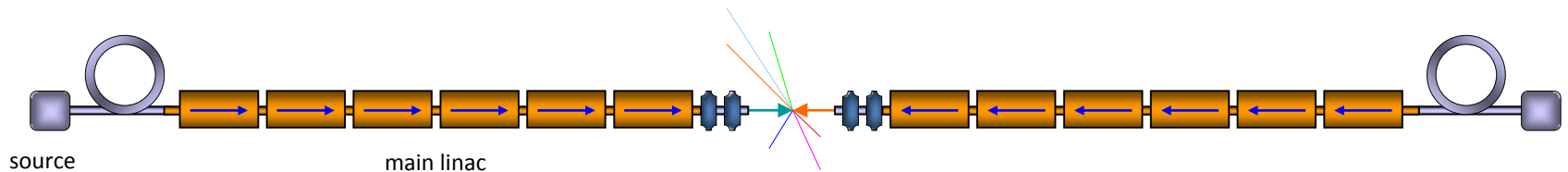

Hardly any synchrotron radiation

Beam can only be used only once
-> strong beam-beam effects

$$C_L = a_L E + b_L$$

Acceleration gradient is an important issue

Simplified Cost Scaling Comparison

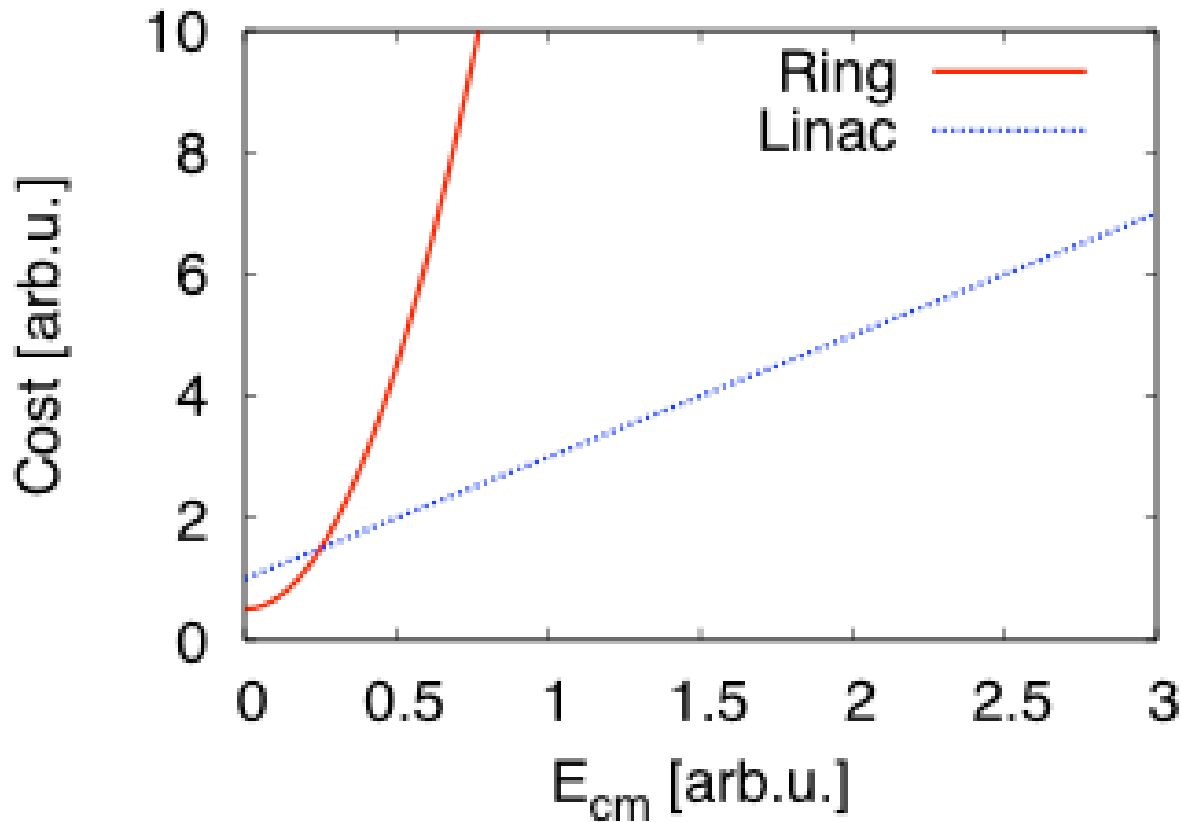

Linac:

$$C_L = a_L E + b_L$$

Ring:

$$C_R = a_R E^2 + b_R$$

Power consumption
behaves similar to cost
for constant luminosity

There will always be an energy where linear colliders are better

Circular vs. Linear Colliders

F. Gianotti

Modified from original version:
<http://arxiv.org/pdf/1308.6176v3.pdf>

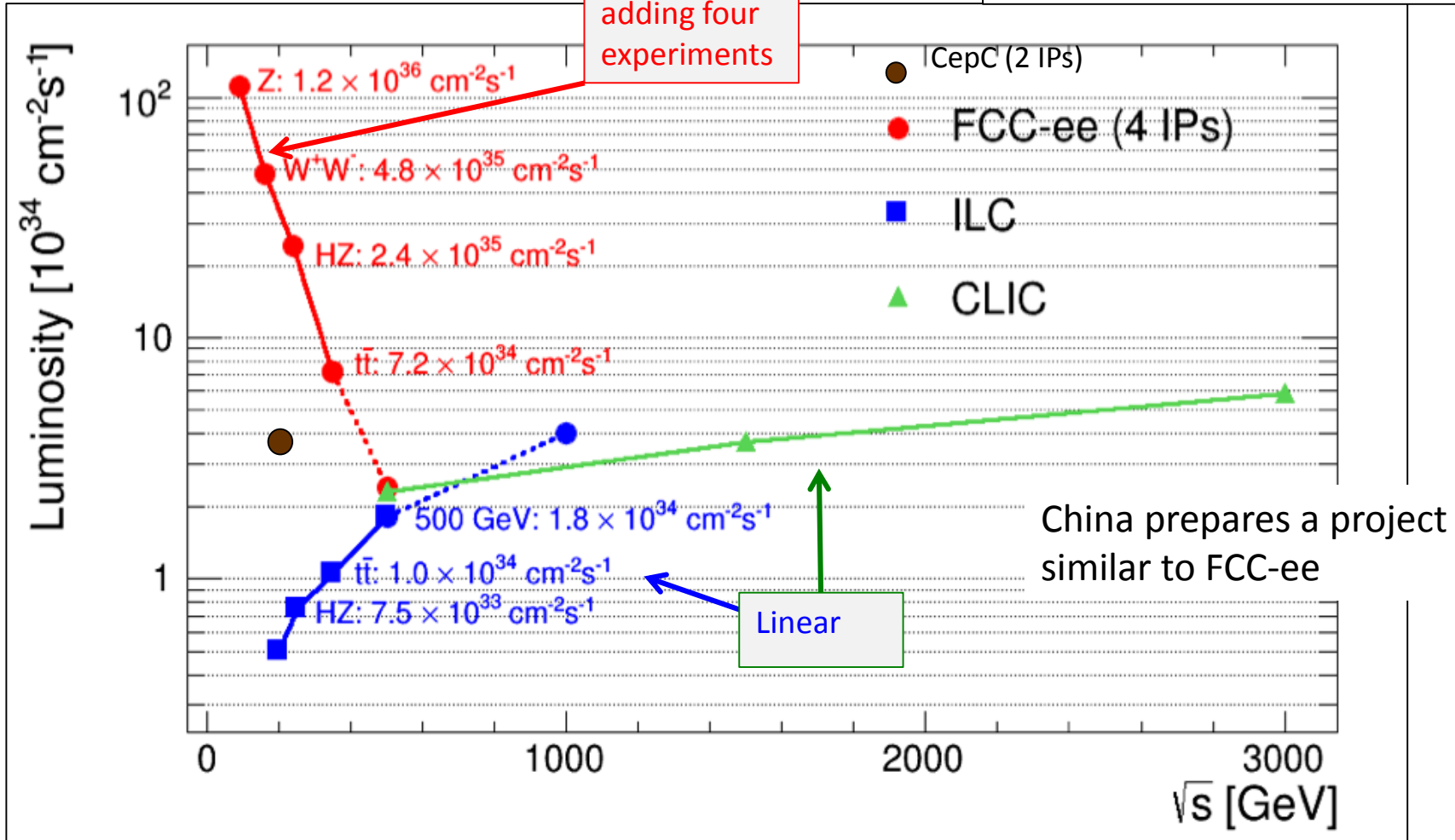

CEPC, SppC, FCC

Note: CEPC/SppC

D. Wang & H. Geng

6th TLEP Workshop

CEPC is

- an **Circular Electron Positron Collider**
- proposed to carry out high precision study on **Higgs bosons**
- to be upgraded to a super **proton-proton collider**

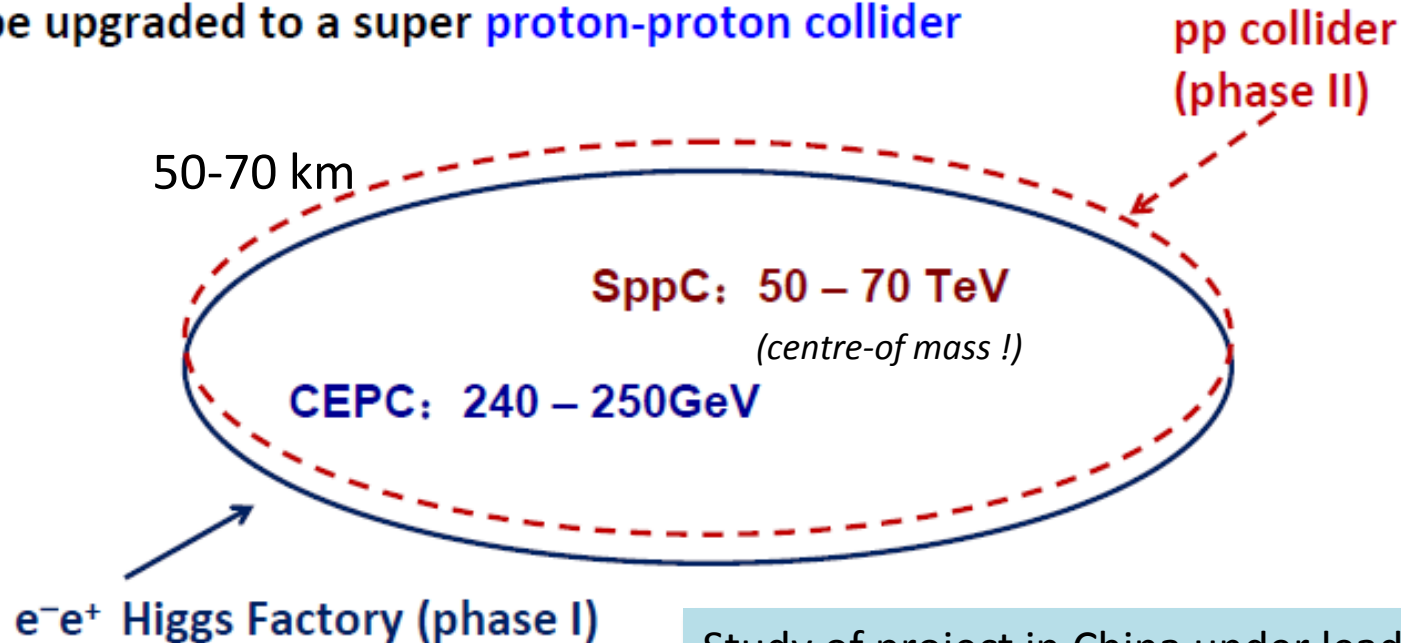

Study of project in China under leadership of IHEP
Emphasis is on lepton collider
CEPC is similar to FCC-ee, SppC similar to FCC-hh
⇒ Will not go into any detail

FCC

FCC-hh:

- 100TeV pp cms energy
 - Can use ions
- ⇒ Defining infrastructure requirements
- ⇒ 100km circumference

FCC-ee:

- e^+e^- collider, 90-350 GeV cms
- Potential intermediate step

FCC-he:

- Hadron-electron option

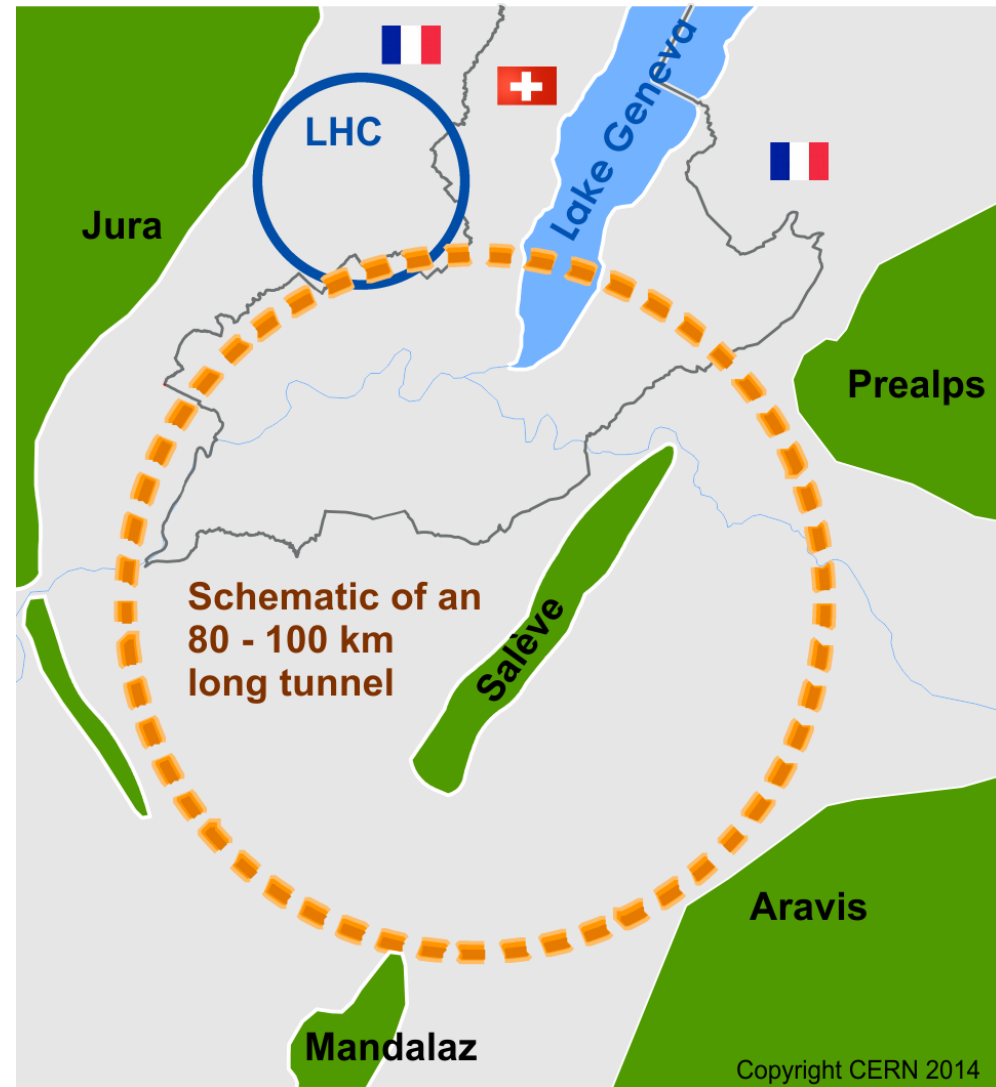

The Key Challenges

- Energy
 - Limited by the machine size and the strength of the bending dipole
 - ⇒ Have to maximise the magnet strength
- Luminosity
 - ⇒ Need to maximise the use of the beam for luminosity production
- Beam power handling
 - Small losses lead to background in detectors and machine
 - Accidental losses
 - ⇒ Need a concept to deal with the beam power
- Cost
 - Push to the limits to reduce cost
- Site
 - Do we have a fitting site (next to CERN)?

Baseline Layout

Circumference 100km

- Two high-luminosity experiments (A and G)
- Two other experiments (F and H)
- Two collimation/extraction insertions
- Two injection insertions, should include RF

Length for arcs 83km

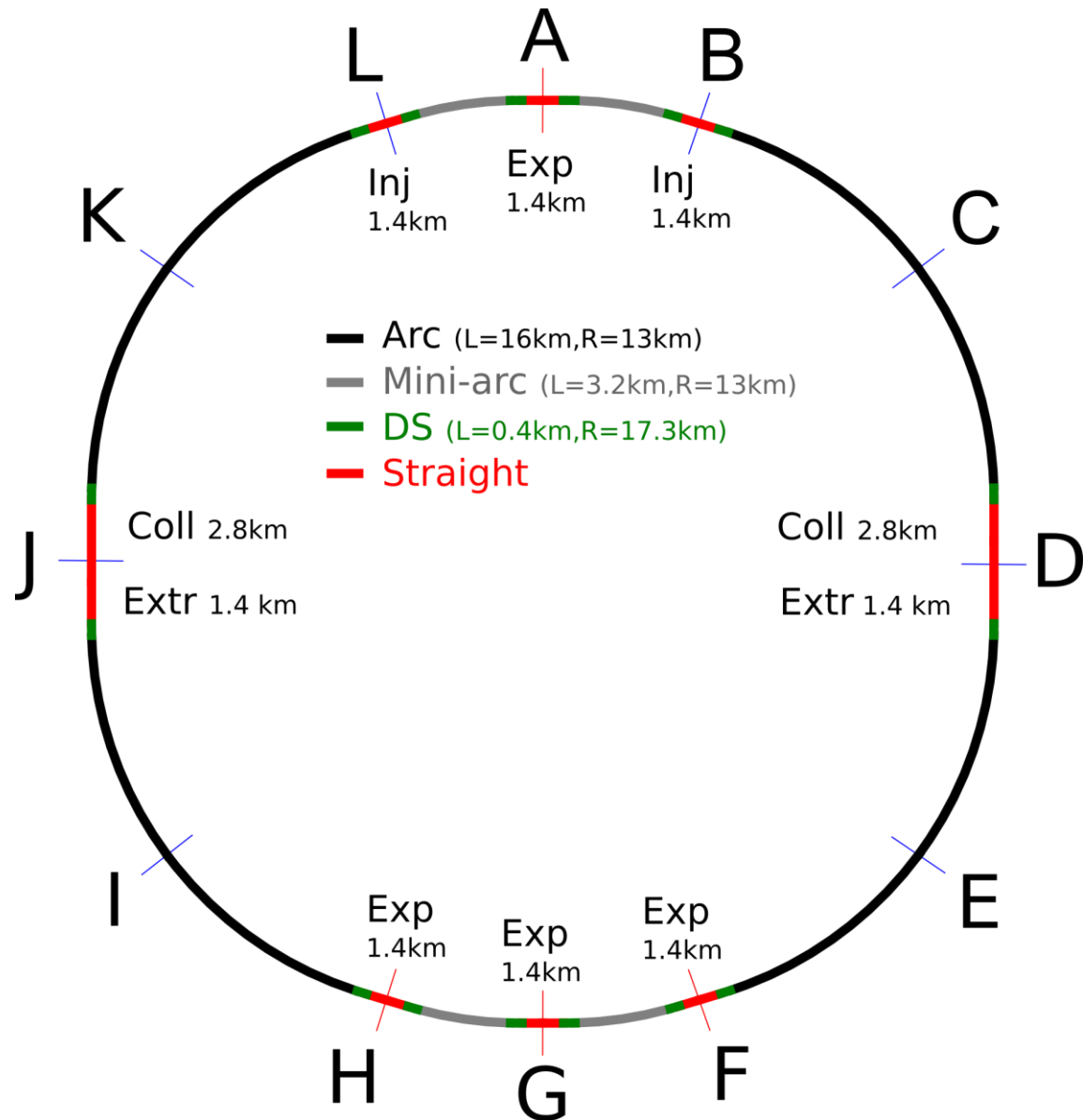

Main FCC-hh Parameters

	LHC	HL-LHC	FCC-hh	
Cms energy [TeV]	14	14	100	100
Luminosity [$10^{34}\text{cm}^{-2}\text{s}^{-1}$]	1	5	5	20
Bunch distance [ns]	25	25	25	25/5
Background events/bx	27	135	170	680 (136)
Bunch length [cm]	7.5	7.5	8	8

Two main experiments

- Two reserve experimental areas used in baseline
- 80% of circumference filled with bunches

Baseline: 250fb^{-1} per year (including shutdowns)

- focus on 25ns spacing

Ultimate: 1000fb^{-1} per year

- more emphasis on 5ns

Dipole Basic Concept ("Cosine Theta")

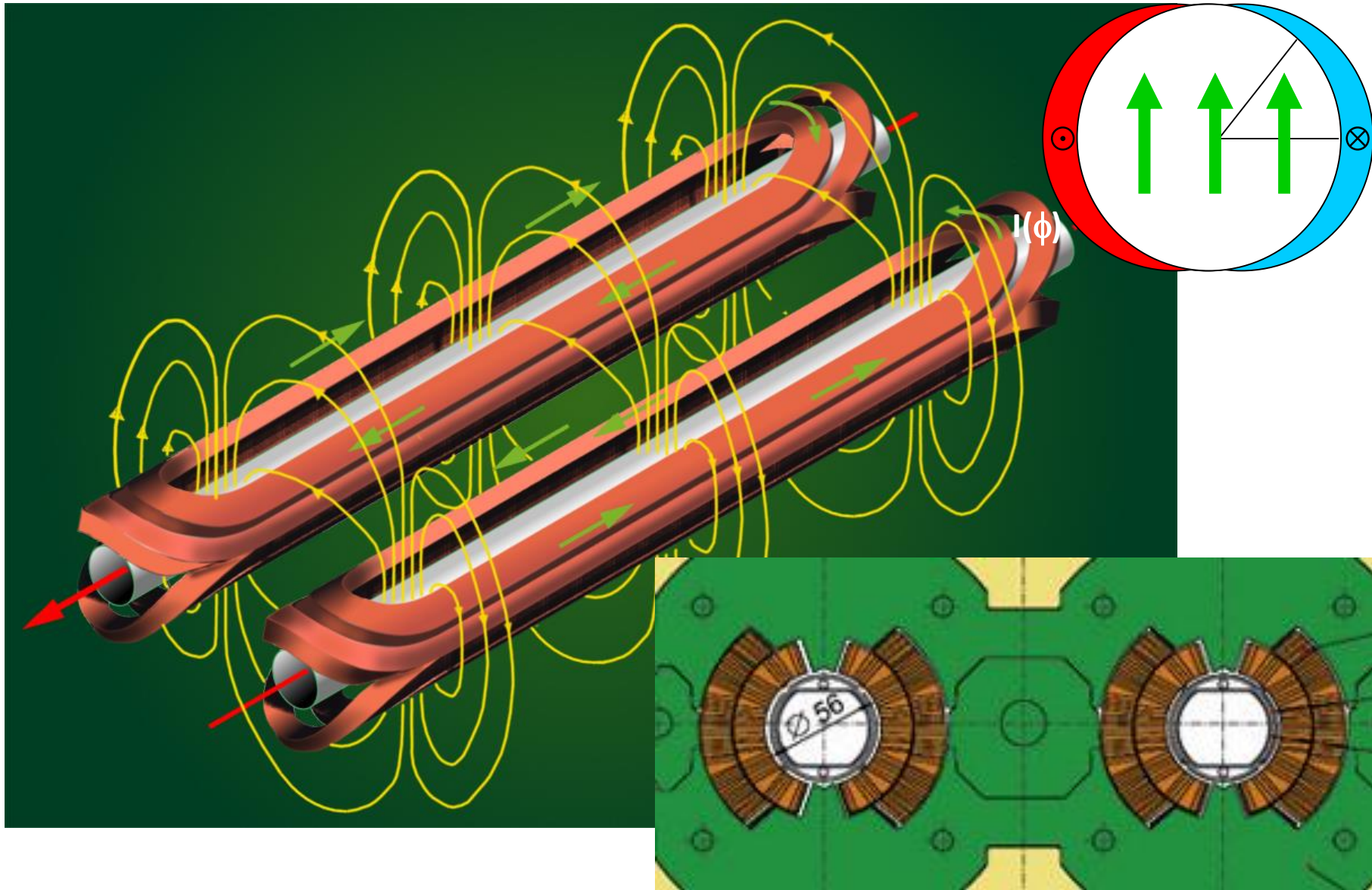

Limits for the Field

The cable can quench (superconductivity breaks down)

- if the current is too high
- If the magnetic field is too high

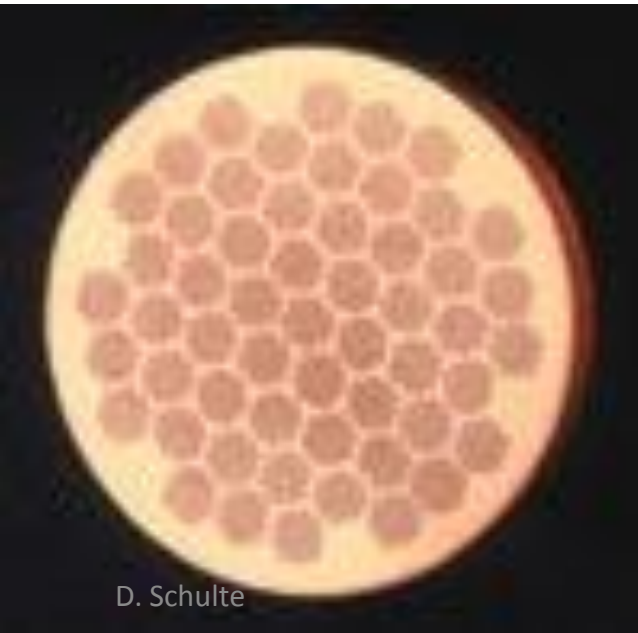
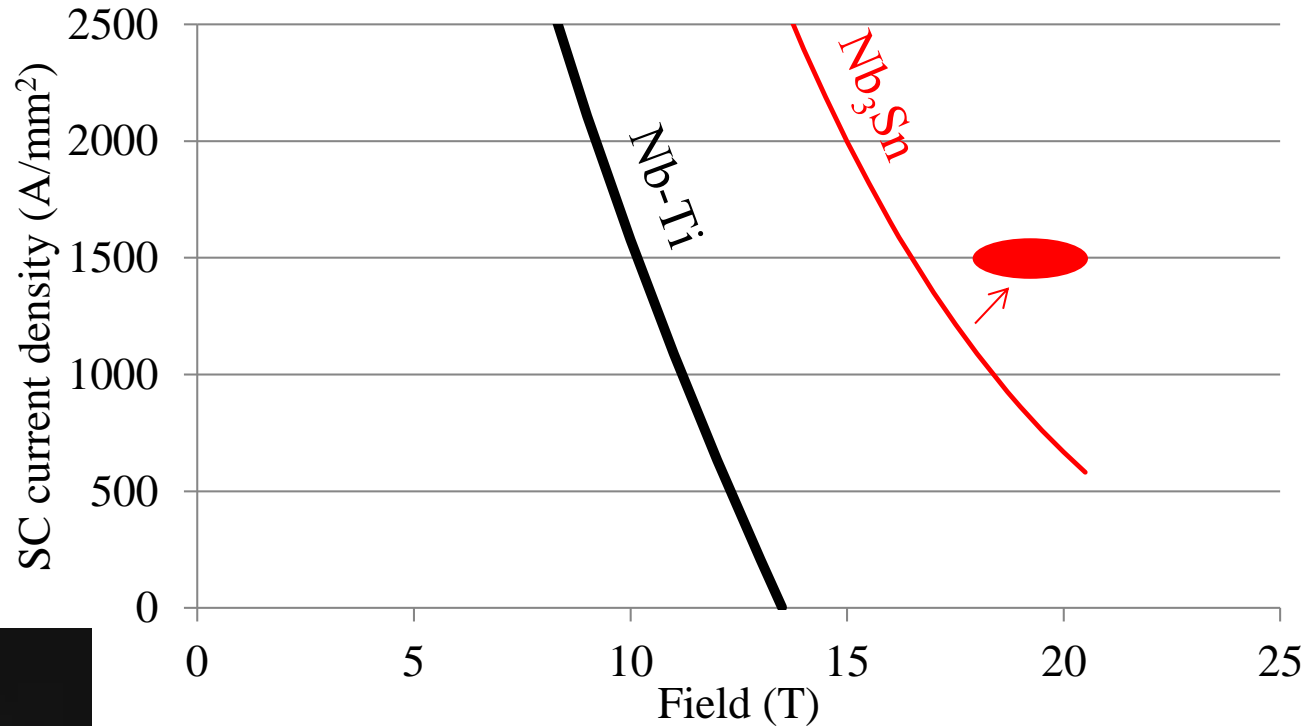

- This limits the achievable field
 - In theory
 - Even lower limit in practice
- Can use different materials
 - Nb-Ti is used for LHC
 - Nb₃Sn is used for high luminosity upgrade

Cost Effective Magnet Design

Nb_3Sn is more costly than Nb-Ti
 \Rightarrow Use both materials

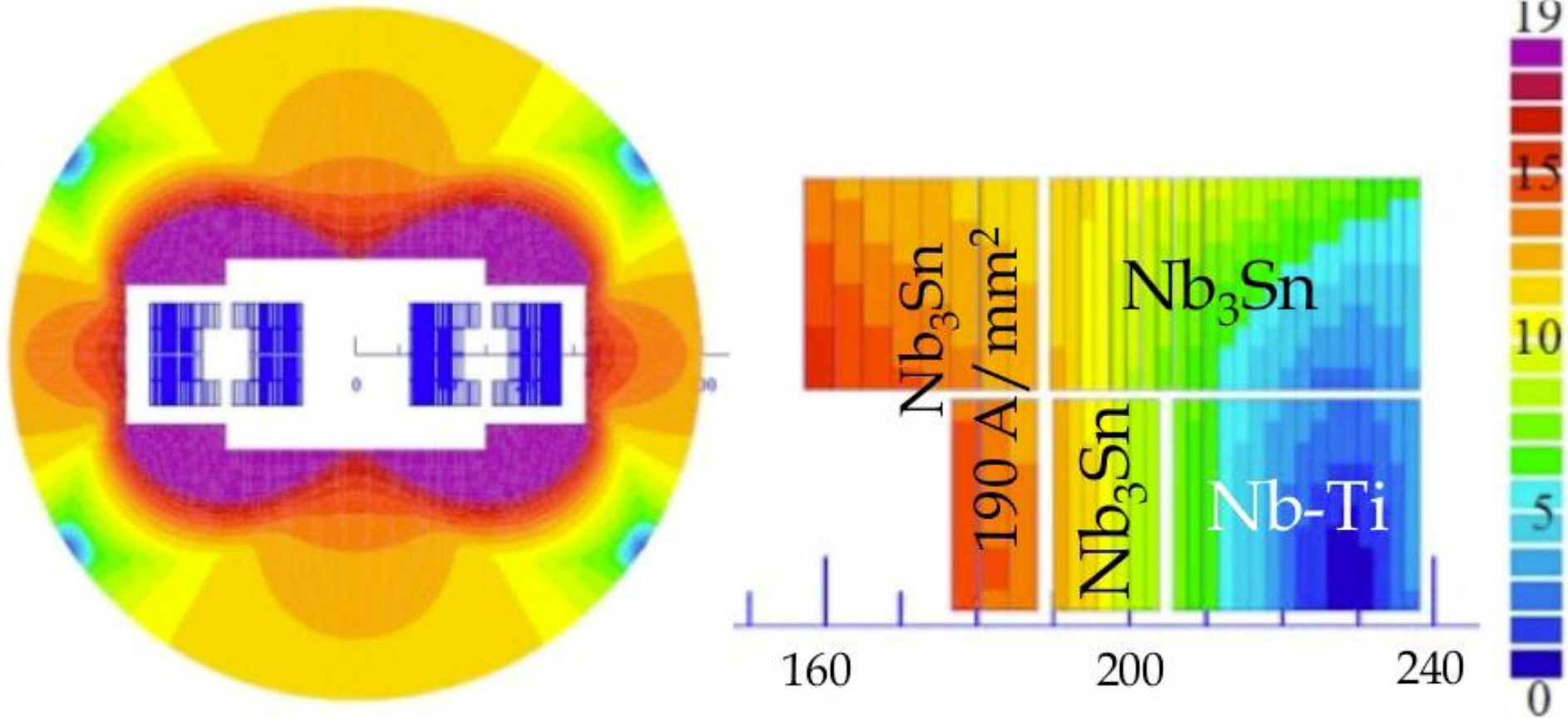

Coil sketch of a 15 T magnet with grading, E. Todesco

FCC-ee Rational

- Use FCC-hh tunnel
- Operate at
 - 90 GeV (“Tera-Z”)
 - 160 GeV (W pairs)
 - 240 GeV (Higgs via Zh)
 - 350 GeV (top threshold, higgs productions via Zh and WW)

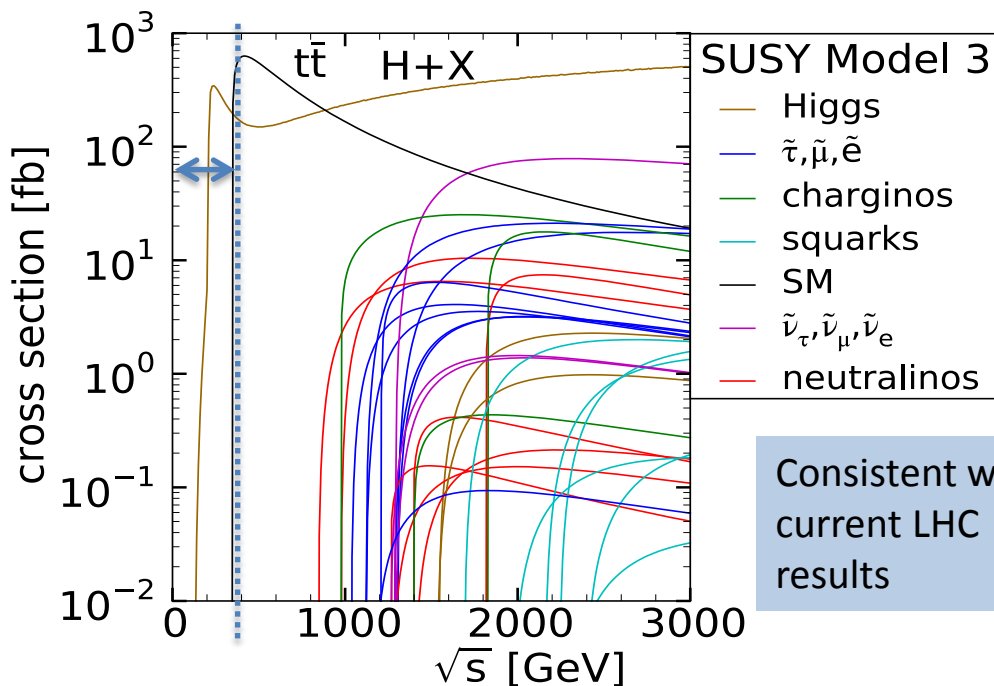

Consistent with current LHC results

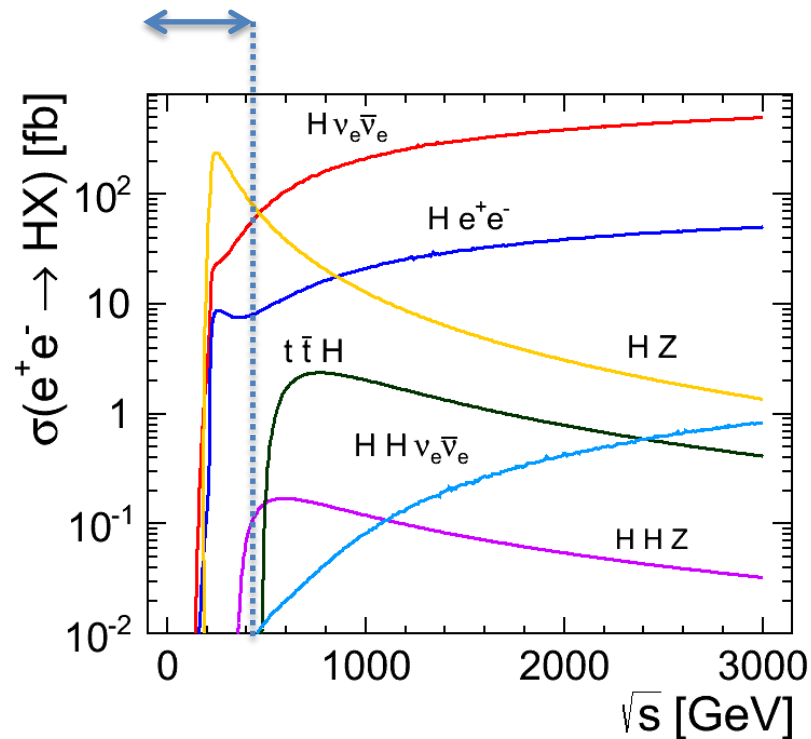

- Limited energy reach
- But proton collider takes care of high energies

FCC-ee Parameters

Parameter	Z	W	H	t	LEP2
E (GeV)	45	80	120	175	104
I (mA)	1400	152	30	7	4
No. bunches	16'700	4'490	1'330	98	4
$\beta^*_{x/y}$ (mm)	500 / 1	500 / 1	500 / 1	1000 / 1	1500 / 50
ε_x (nm)/ ε_y (pm)	29/60	3.3/7	1/2	2/2	30-50/~250
σ_x (μ m)/ σ_y (nm)	120/250	40/84	22/45	45/45	250/3500
ξ_{ψ_y}	0.03	0.06	0.09	0.09	0.07
L (10^{34} cm $^{-2}$ s $^{-1}$)	28	12	6.0	1.8	0.012

Using flat beams

Significant luminosity increase compared to LEP:

Smaller emittances, beta-functions, larger power consumption

$$U_0 \propto \frac{E^4}{\rho}$$

Now even higher luminosities are being discussed

Luminosity Lifetime

Luminosity lifetime is dominated by radiative Bhabha scattering

$$\tau_{ee} \propto \frac{I}{L \sigma_{ee} n_{ip}}$$

(total cross-section $\sigma_{ee} \approx 0.21\text{b}$)

=> Lifetimes down to ~ 15 minutes at 350GeV

=> Continuous top-up injection

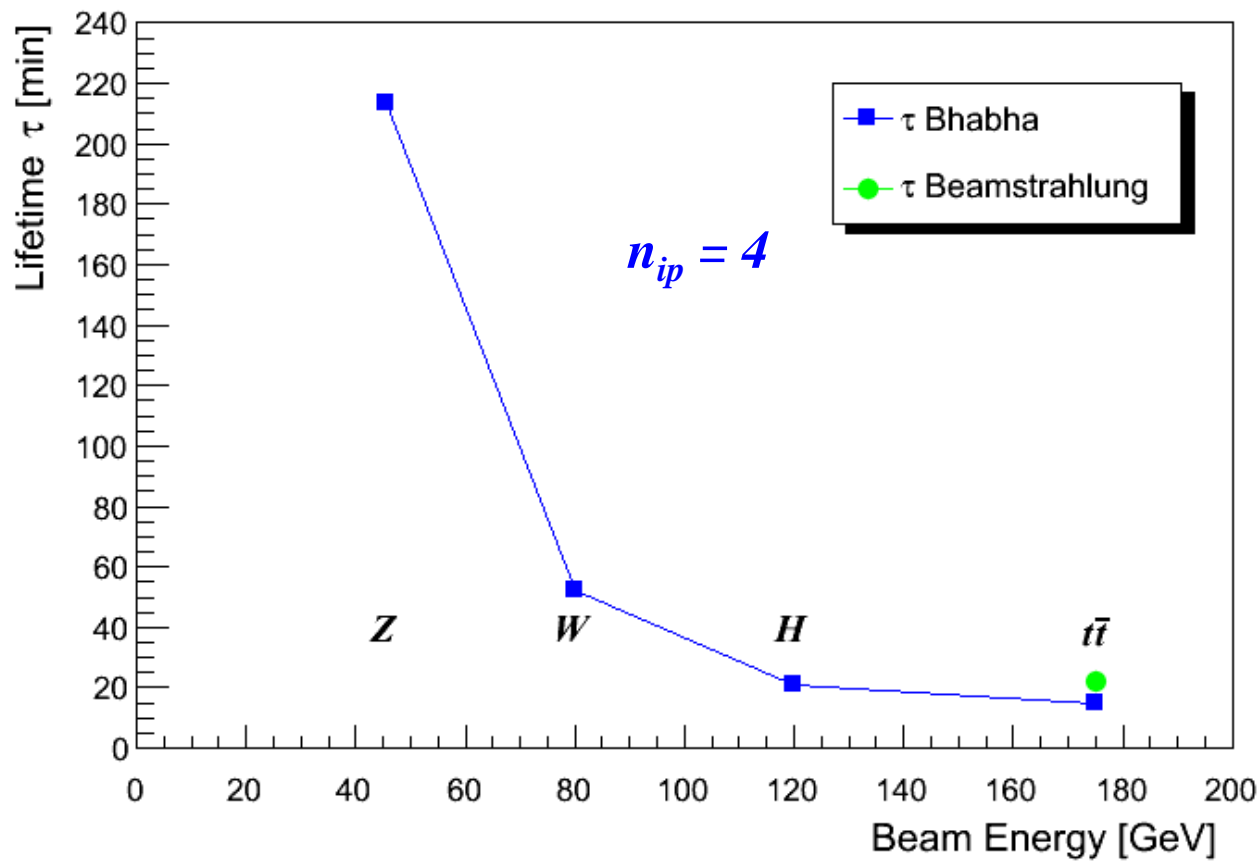
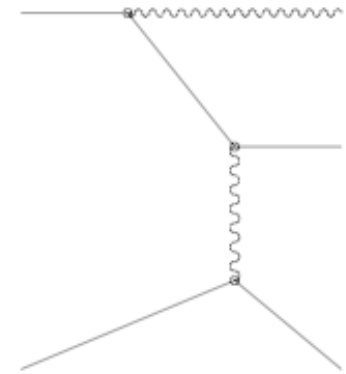
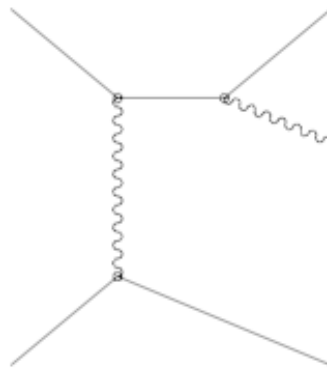

Top-up Injection

- Boost energy in booster ring to collision energy
- Inject into collider ring on top of circulating beam
- Requires third ring
- Can keep collider current almost constant, even with short lifetimes
- Tested in B-factories

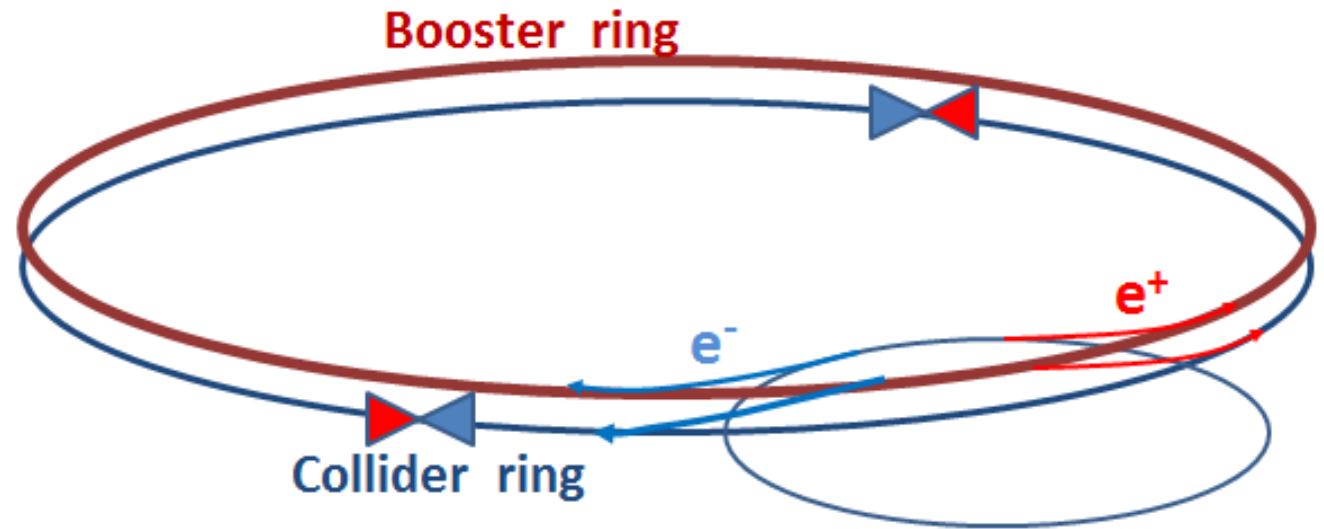

Injection into booster at 20GeV
Injection into collider ring very 10s or so

Linear Colliders

Generic Linear Collider



Generic Linear Collider

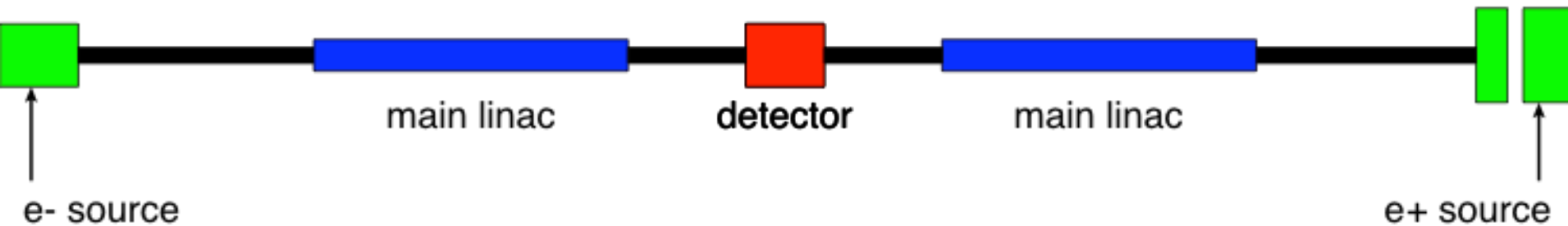

The main linac provides the energy of the beam

Issue 1: the gradient

Generic Linear Collider

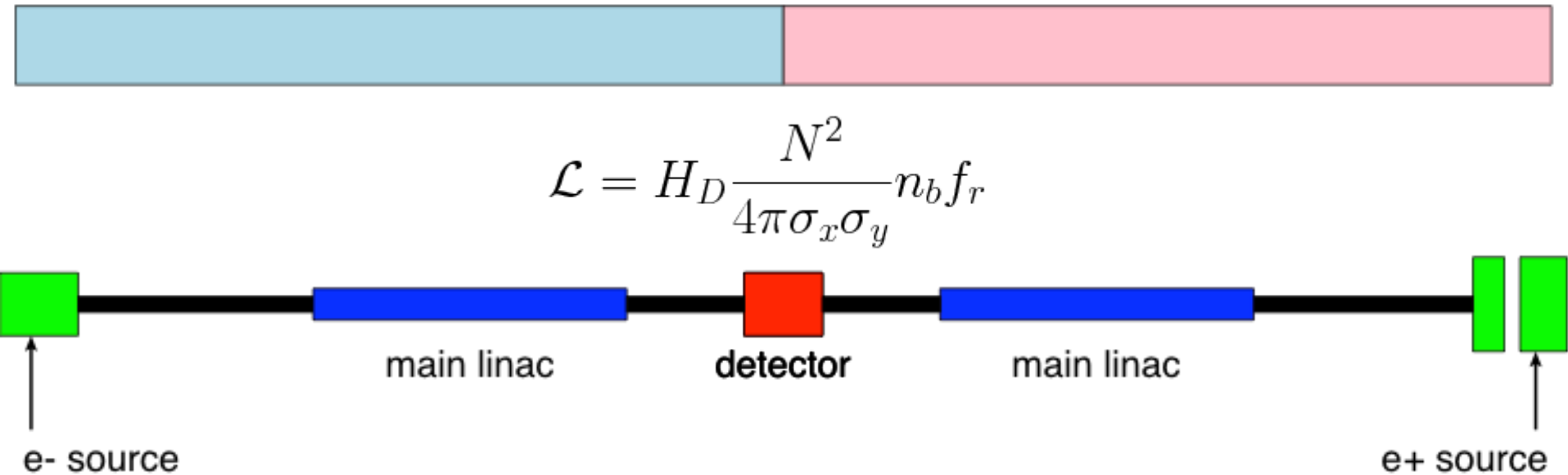

But little luminosity, since beams collider only once

Need very small σ_x and σ_y

Generic Linear Collider

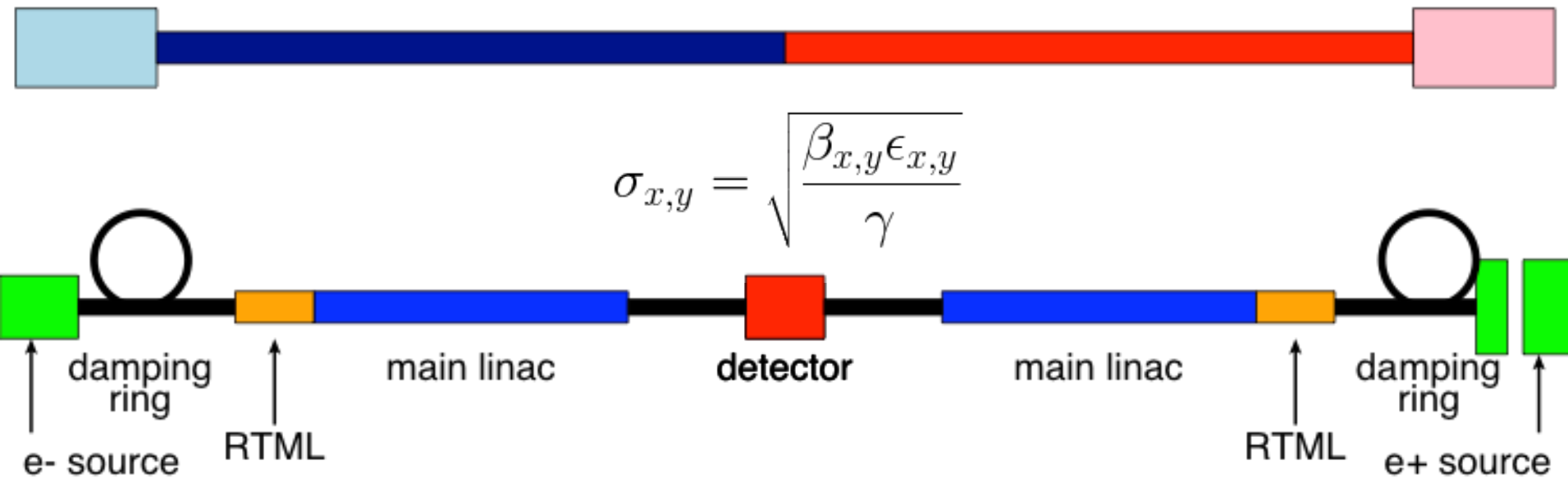

The damping rings reduce the phase space (emittance $\epsilon_{x,y}$) of the beam
 The RTML (ring-to-main linac transport) reduces the bunch length

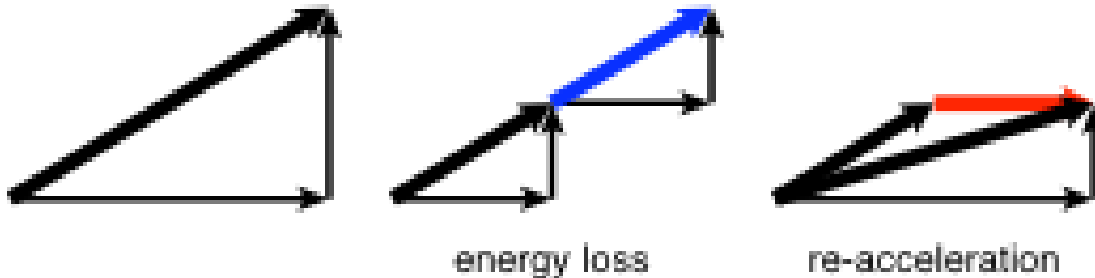

Generic Linear Collider

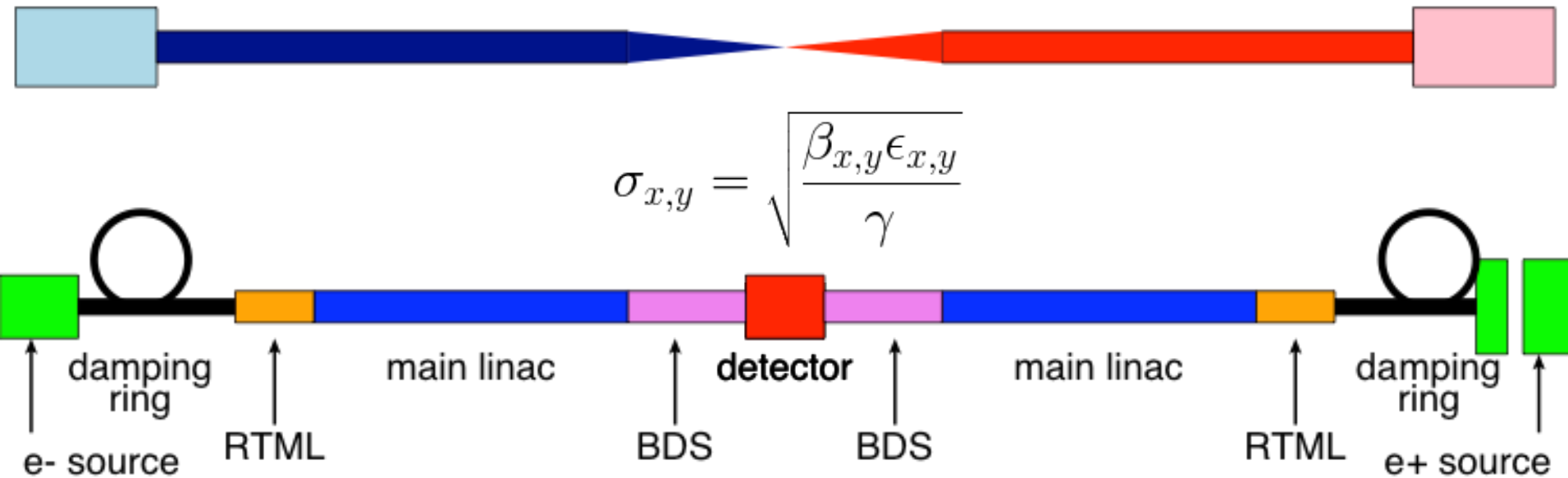

The beam delivery system (BDS) squeezes the beam as much as possible, i.e. reduces $\beta_{x,y}$

ILC Layout

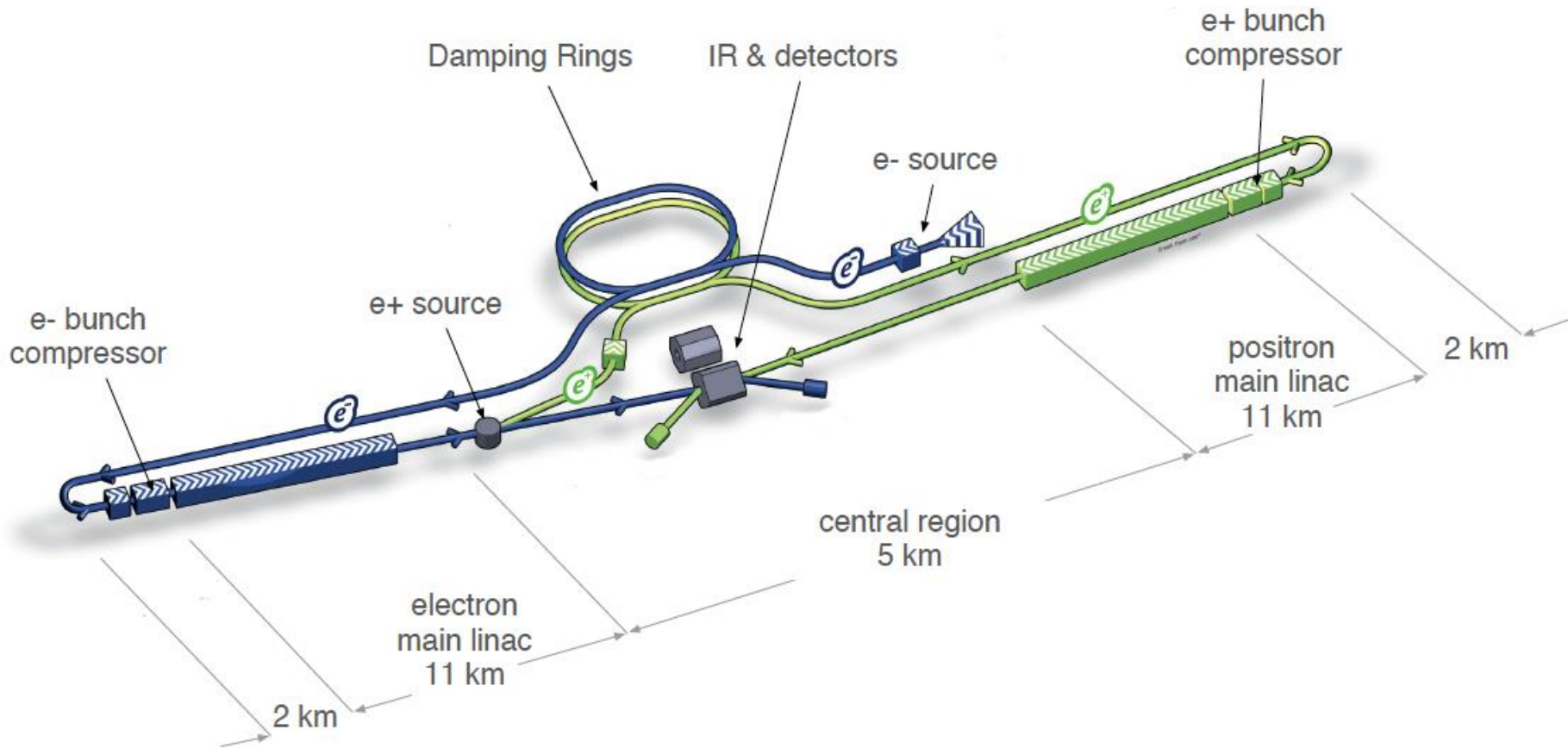

CLIC Layout at 3 TeV

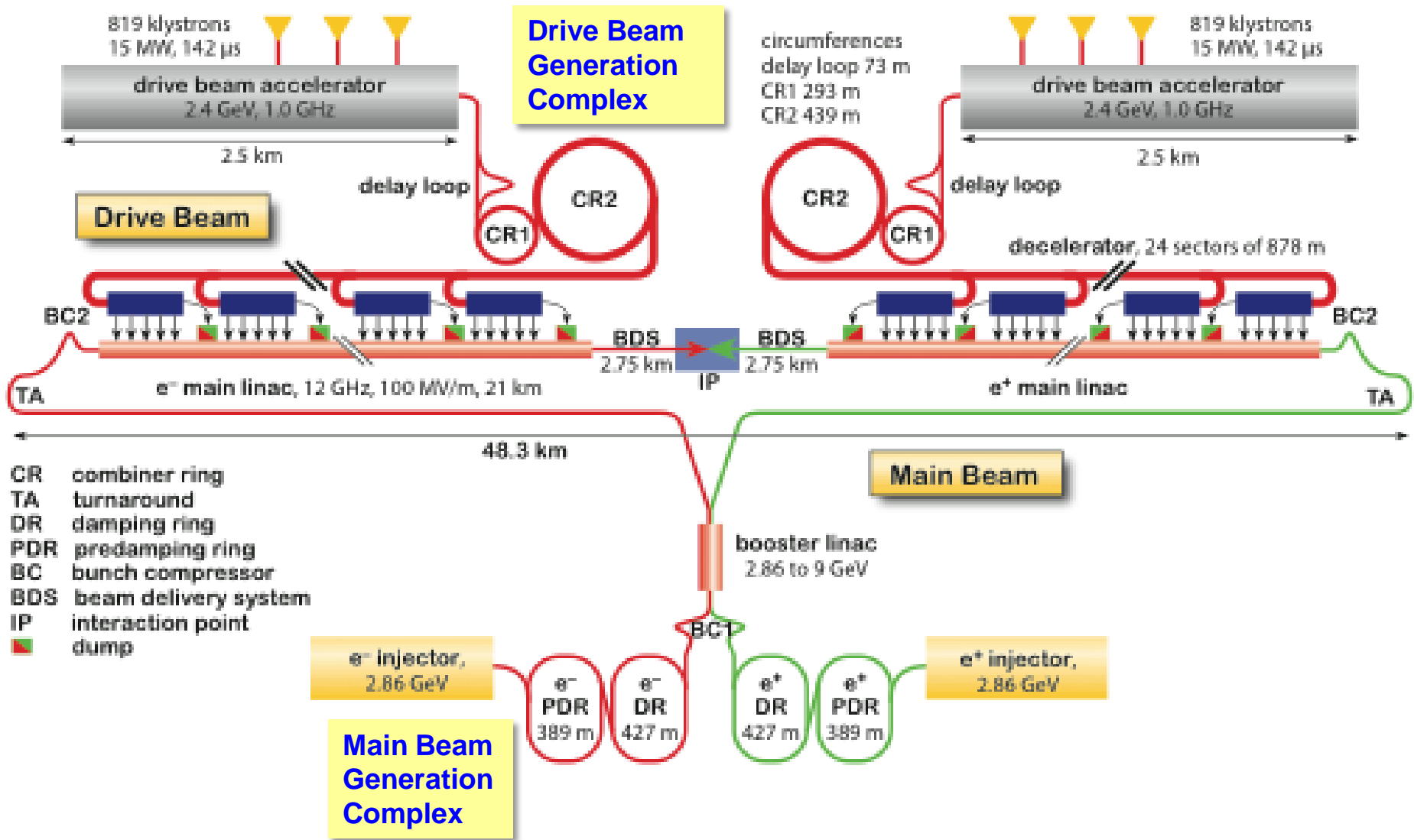

Cavity/Accelerating Structure

ILC cavity

1.3 GHz, superconducting

Target effective operational
31.5MV/m

Target gradient 35MV/m

$Q_0 \approx 10^{10}$

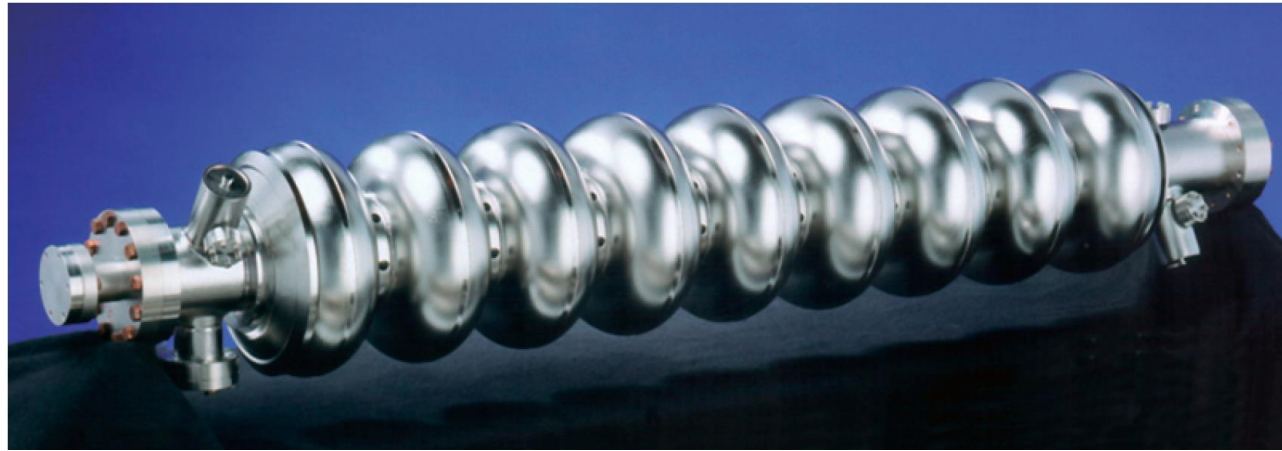

CLIC accelerating structure

12 GHz, normal conducting

Target loaded gradient 100MV/m

Target unloaded gradient 120MV/m

$Q_0 \approx 6 \cdot 10^3$

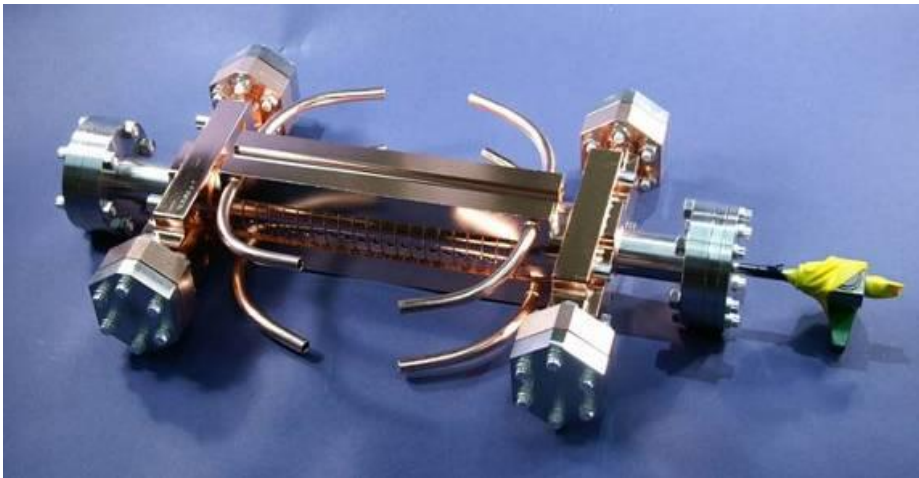

ILC TDR

Volume 1 - Executive Summary

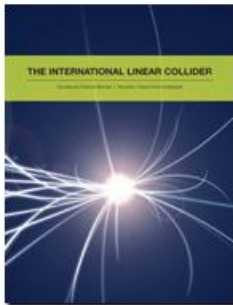

[Download the pdf](#)  (9.5 MB)

Volume 2 - Physics

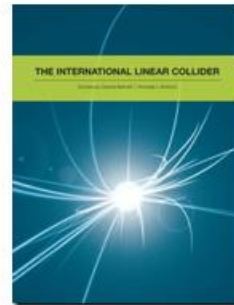

[Download the pdf](#)  (9.5 MB)

Volume 3 - Accelerator

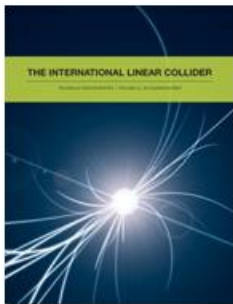

**Part I:
R&D in the Technical
Design Phase**

[Download the pdf](#)  (91 MB)

Volume 3 - Accelerator

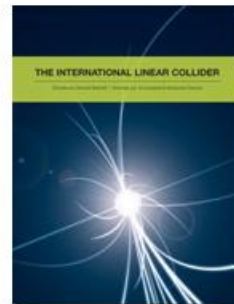

**Part II:
Baseline Design**

[Download the pdf](#)  (72 MB)

Volume 4 - Detectors

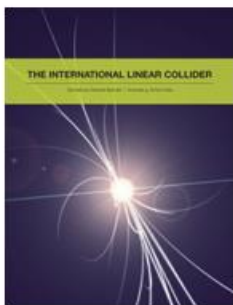

[Download the pdf](#)  (66 MB)

From Design to Reality



[Download the pdf](#)  (5.5 MB)

[Visit the web site](#)

The CLIC CDR documents

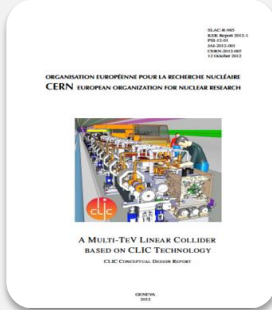

Vol 1: The CLIC accelerator and site facilities

- CLIC concept with exploration over multi-TeV energy range up to 3 TeV
- Feasibility study of CLIC parameters optimized at 3 TeV (most demanding)
- Consider also 500 GeV, and intermediate energy range
- <https://edms.cern.ch/document/1234244/>

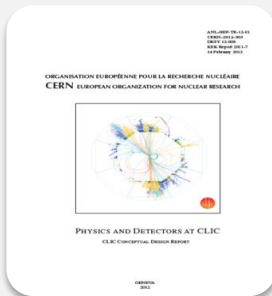

Vol 2: Physics and detectors at CLIC

- Physics at a multi-TeV CLIC machine can be measured with high precision, despite challenging background conditions
- External review procedure in October 2011
- <http://arxiv.org/pdf/1202.5940v1>

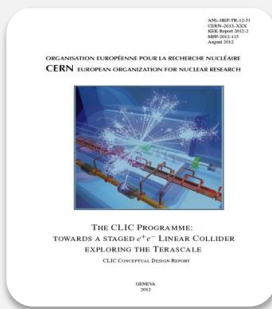

Vol 3: "CLIC study summary"

- Summary and available for the European Strategy process, including possible implementation stages for a CLIC machine as well as costing and cost-drives
- Proposing objectives and work plan of post CDR phase (2012-16)
- <http://arxiv.org/pdf/1209.2543v1>

In addition a shorter overview document was submitted as input to the European Strategy update, available at:

<http://arxiv.org/pdf/1208.1402v1>

An input document to Snowmass 2013 has also been submitted: <http://arxiv.org/abs/1305.5766>

Linear Collider Experiment

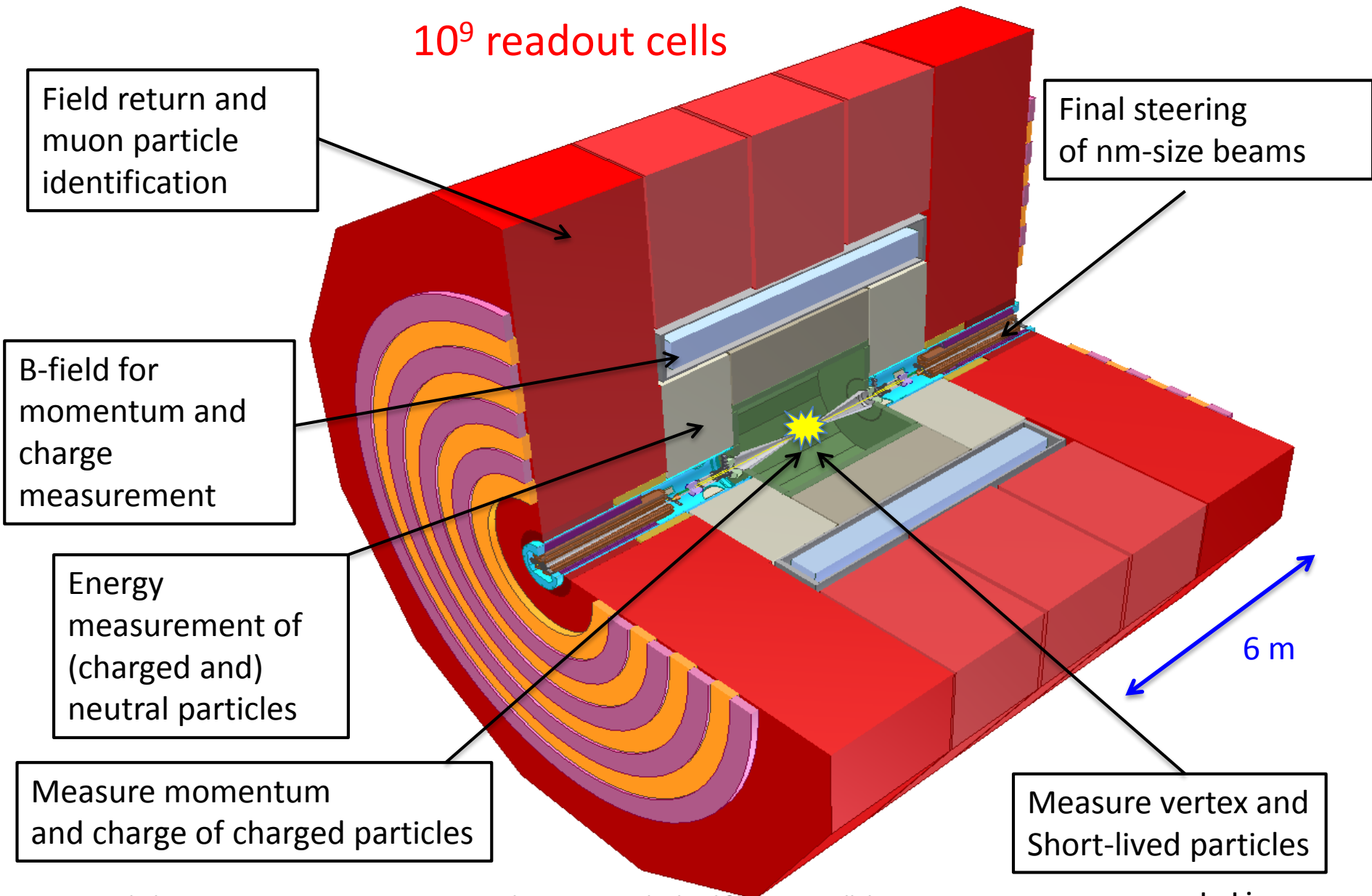

ILC Detector Concepts

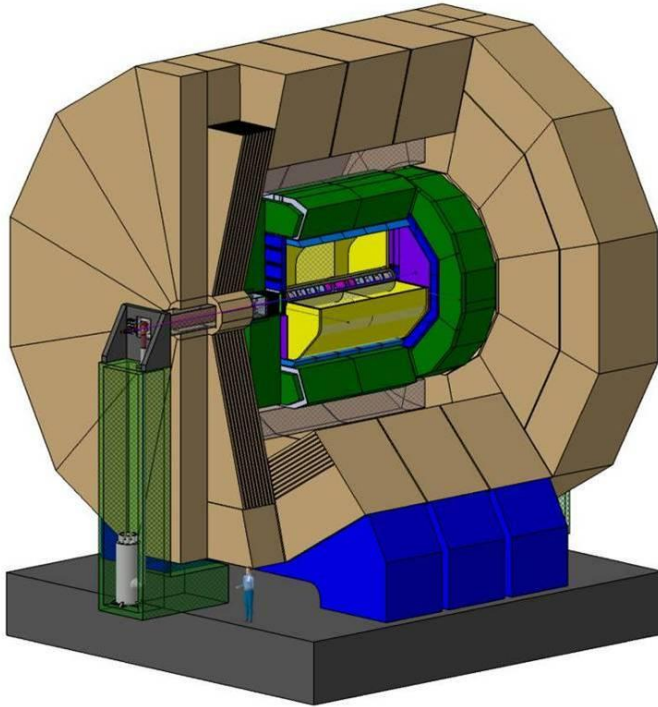

ILD

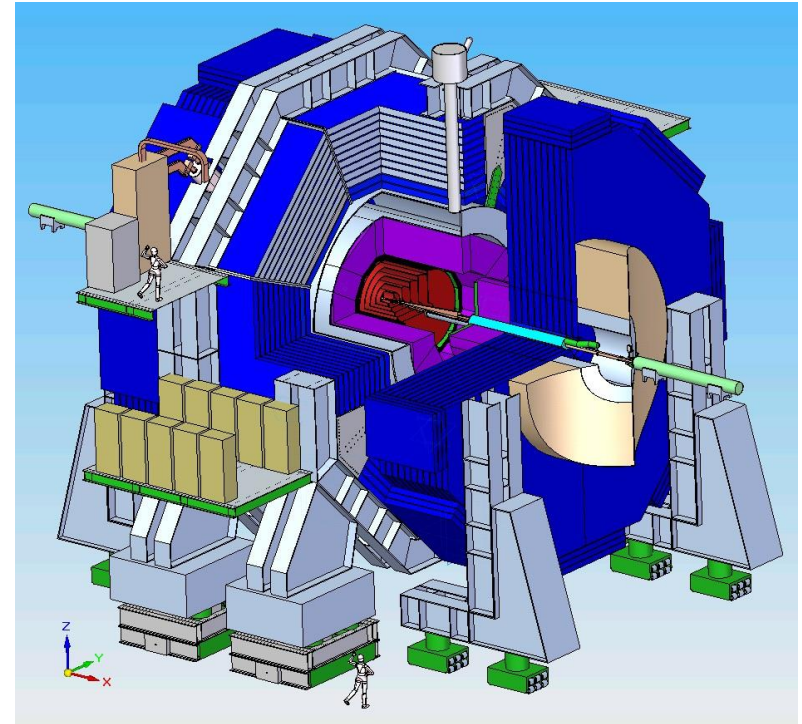

SiD

CLIC detector concepts are based on SiD and ILD.
Modified to meet CLIC requirements

ILC and CLIC Main Parameters

Parameter	Symbol [unit]	SLC	ILC	CLIC
Centre of mass energy	E_{cm} [GeV]	92	500	3000
luminosity	L [$10^{34}\text{cm}^{-2}\text{s}^{-1}$]	0.0003	1.8	6
Luminosity in peak	$L_{0.01}$ [$10^{34}\text{cm}^{-2}\text{s}^{-1}$]	0.0003	1	2
Gradient	G [MV/m]	20	31.5	100
Particles per bunch	N [10^9]	37	20	3.72
Bunch length	σ_z [μm]	1000	300	44
Collision beam size	$\sigma_{x,y}$ [nm/nm]	1700/600	474/5.9	40/1
Vertical emittance	$\epsilon_{x,y}$ [nm]	3000	35	20
Bunches per pulse	n_b	1	1312	312
Distance between bunches	Δz [mm]	-	554	0.5
Repetition rate	f_r [Hz]	120	5	50

ILC has parameter sets from 250GeV to 1TeV

CLIC has parameter sets from 250GeV to 3TeV

Luminosity and Parameter Drivers

Can re-write normal
luminosity formula

$$\mathcal{L} = H_D \frac{N^2}{4\pi\sigma_x\sigma_y} n_b f_r$$

$$\mathcal{L} \propto H_D \frac{N}{\sigma_x} N n_b f_r \frac{1}{\sigma_y}$$

Luminosity spectrum

Beam power

Beam Quality (+bunch length)

Need to ensure that we can achieve each parameter

Luminosity and Parameter Drivers

Can re-write normal
luminosity formula

$$\mathcal{L} = H_D \frac{N^2}{4\pi\sigma_x\sigma_y} n_b f_r$$

See main linac lecture
(and ILC and CLIC lecture)

$$\mathcal{L} \propto H_D \frac{N}{\sigma_x} N n_b f_r \frac{1}{\sigma_y}$$

Luminosity spectrum

Beam power

Beam Quality (+bunch length)

Need to ensure that we can achieve each parameter

Beam-beam Effect

Bunches are squeezed strongly to maximise luminosity



Electron magnetic fields are very strong



Beam particles travel on curved trajectories



They emit photons (O(1)) (beamstrahlung)



They collide with less than nominal energy

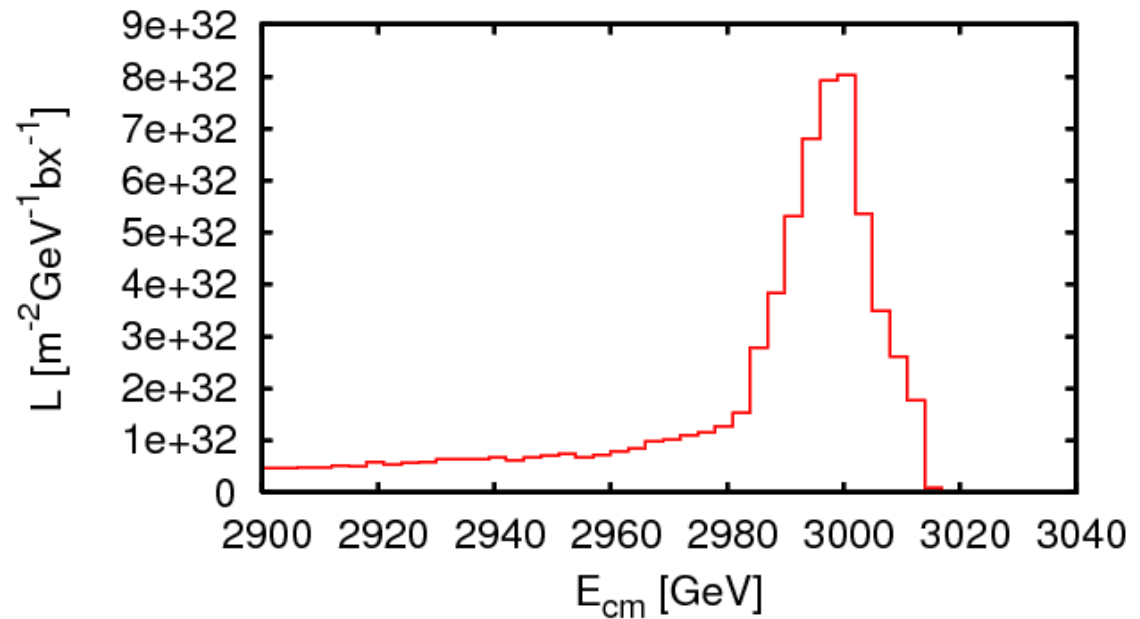
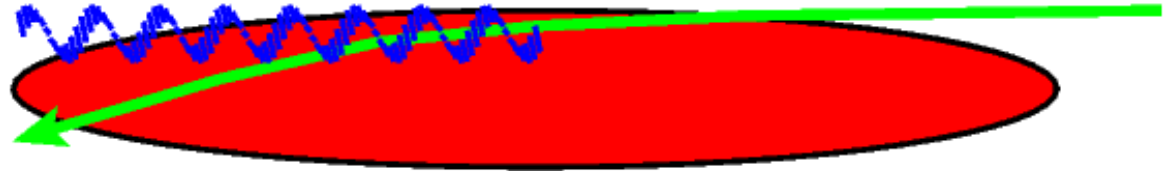

Beamstrahlung Optimisation

For low energies (classical regime) number of emitted photons

$$n_\gamma \propto E_\gamma \propto \frac{N}{\sigma_x + \sigma_y}$$

$$\mathcal{L} \propto \frac{N}{\sigma_x \sigma_y}$$

Hence use $\sigma_x \gg \sigma_y$

$$\sigma_x + \sigma_y \approx \sigma_x$$

$$\mathcal{L} \propto H_D \left(\frac{N}{\sigma_x} \right) N n_b f_r \frac{1}{\sigma_y}$$

For CLIC at 3TeV (quantum regime)

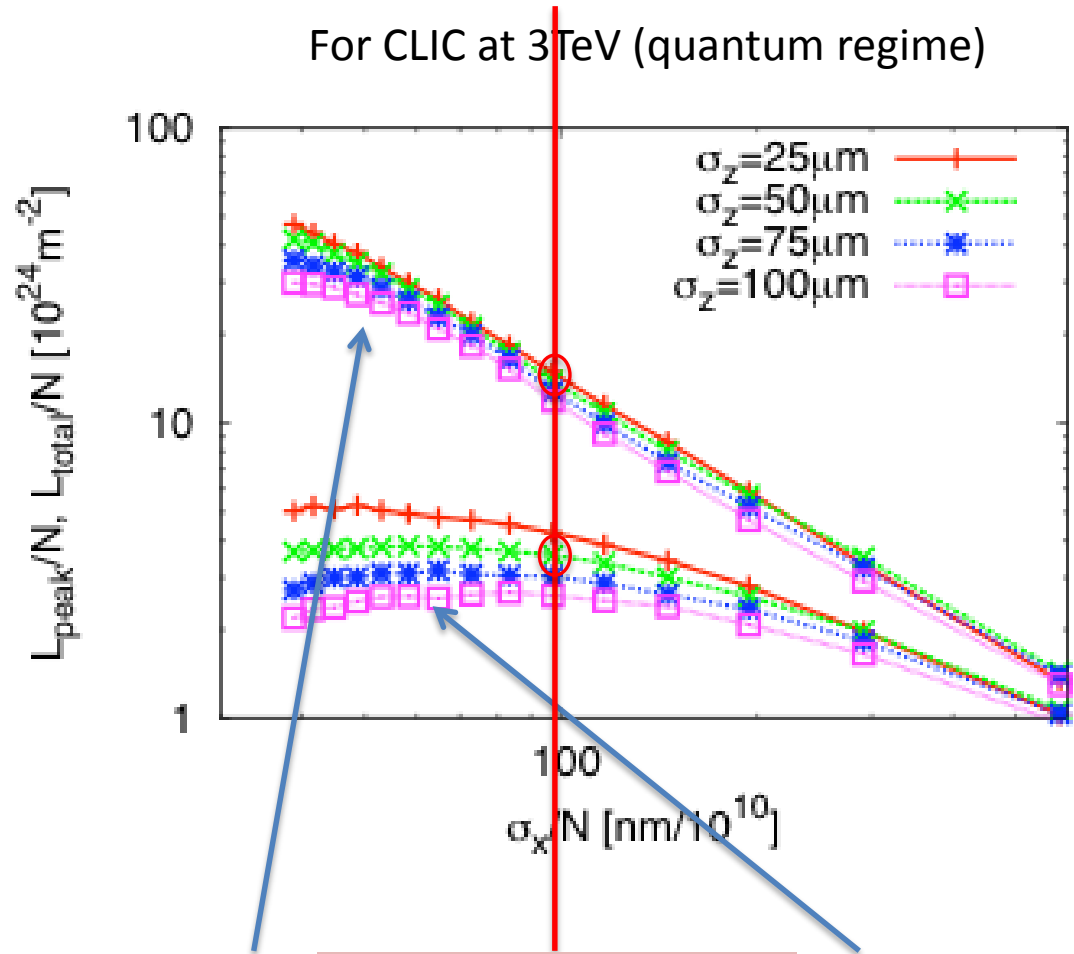

Total luminosity grows for smaller beams
 CLIC parameter choice
 luminosity in peak starts to decrease again

Ultra Low Beam Emittances/Sizes

- Natural to produce flat beams in the damping rings
 - You make the beam go round in the horizontal
 - It is excited by noise in the synchrotron radiation
- Important challenge to maintain a small vertical emittance from the damping ring to the IP
- Address the issue by
 - Clever system design
 - Clever tuning algorithms
 - Technical development of components
 - Experiments

⇒ See the next lectures

Link to FELs

LCLS in operation at SLAC
using the old SLC linac (S-band)

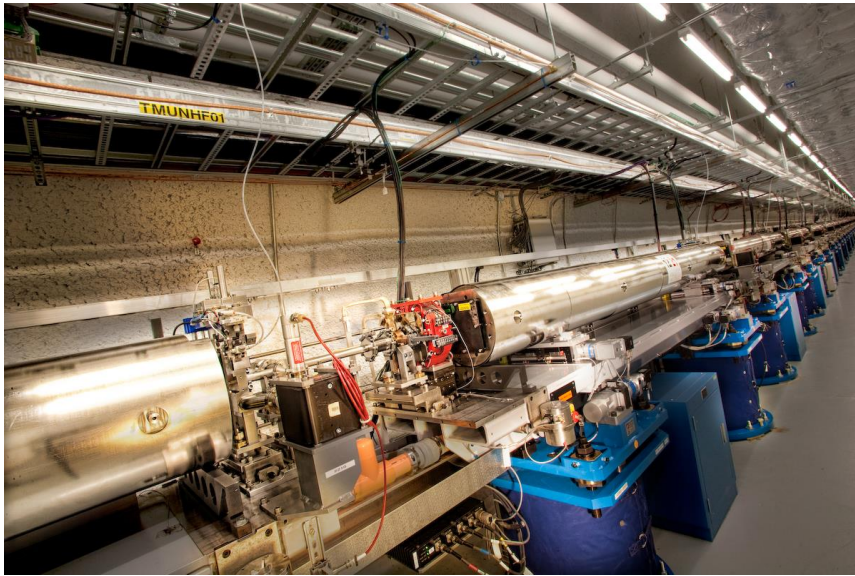

European X-FEL under construction at DESY
Based on TESLA-technology (same as for ILC)



Other S-band based FELs exist as well:
e.g. Trieste, Shanghai, ...

Based on C-band developed for linear colliders:
SACLA operating at SPRING-8
Swiss FEL under construction at PSI

Design studies planned for FELs using
X-band linac technology:
Ankara, Trieste, Melbourne

Muon Collider

Muon Collider Concept

Muons are heavy so they emit little synchrotron radiation

$$m_{\mu} \approx 106 \text{ MeV}/c^2 \approx 207 m_e$$

But they do not live very long

$$t_m \gg 2.2 \text{ ms} \cdot g$$

Produce them, cool them quickly and let them collide in a small ring

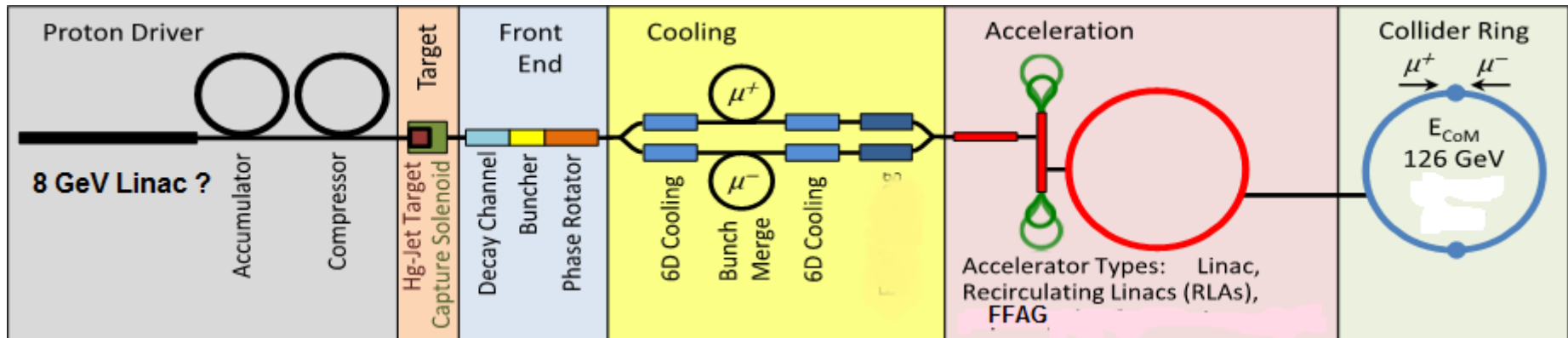
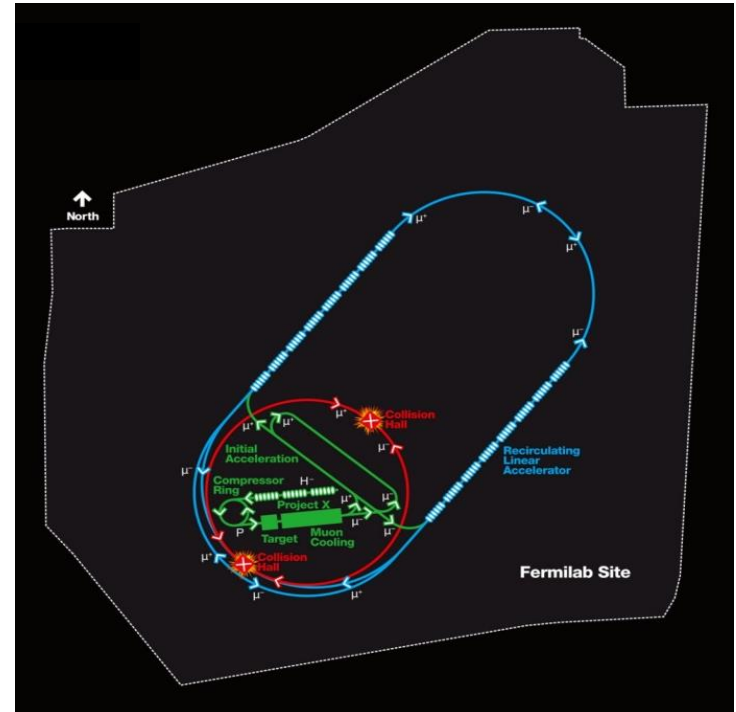

Final Transverse Cooling System

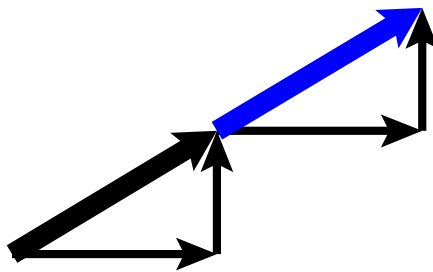
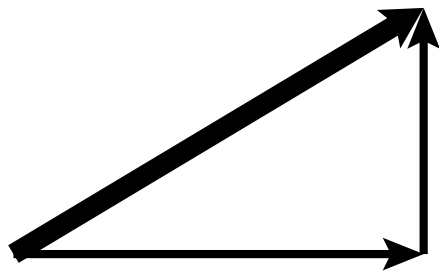
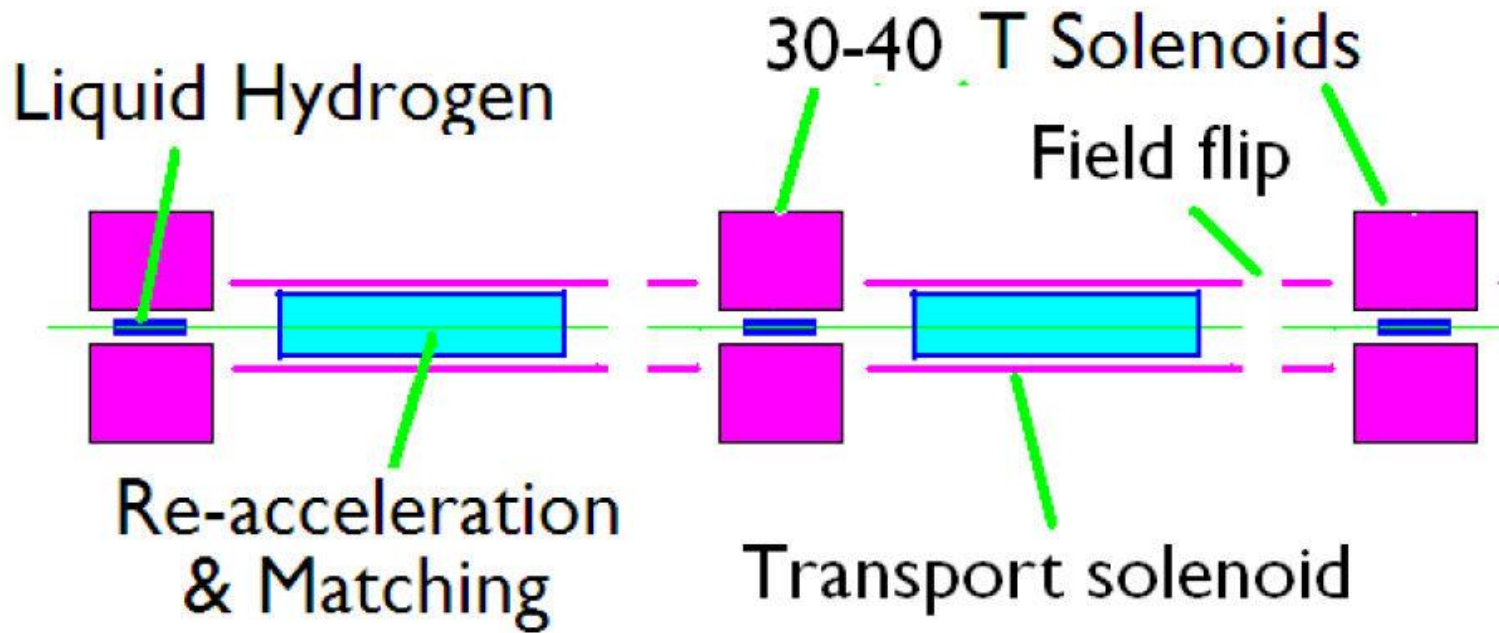

energy loss

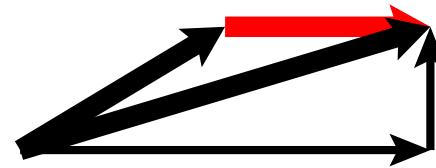

re-acceleration

MICE

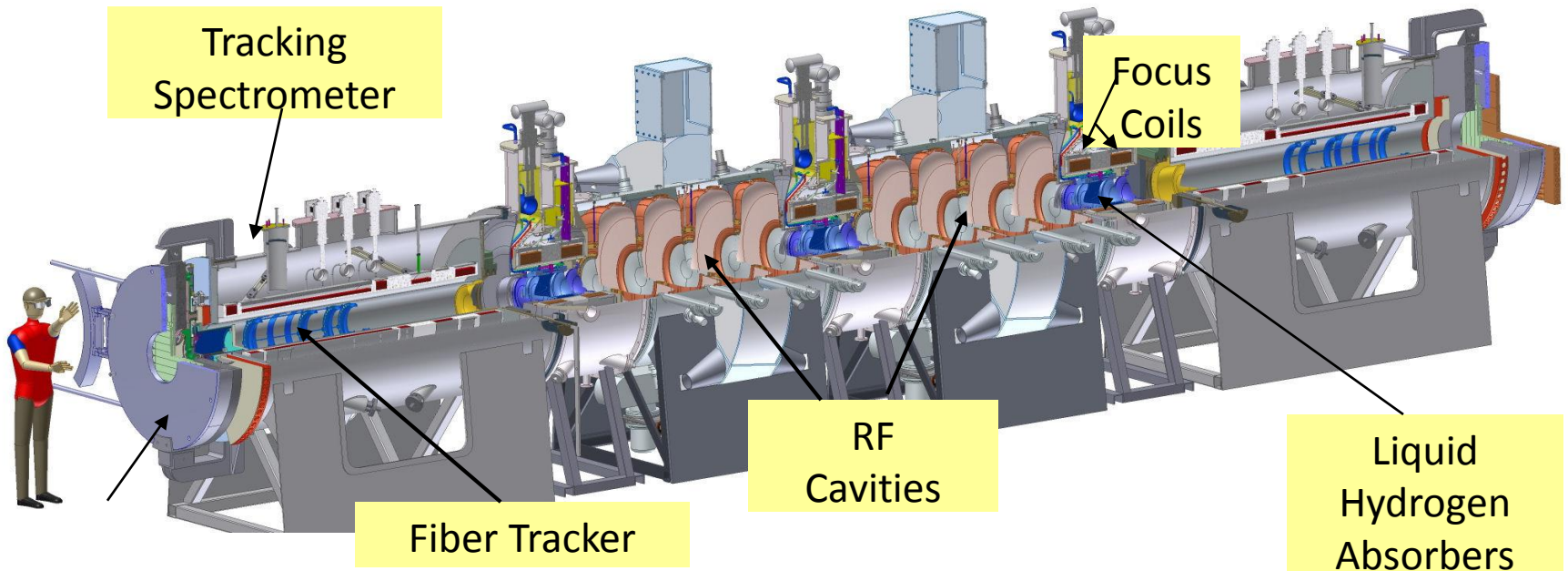

Under construction

Will test 10% 4D emittance reduction (0.1% accuracy)

Single particle experiment

Linda Coney, UCR

<http://www.mice.iit.edu/>

Muon Collider Parameters

M. Palmer

Muon Collider Parameters					
Parameter	Units	Higgs	Multi-TeV		
		Production Operation			Accounts for Site Radiation Mitigation
CoM Energy	TeV	0.126	1.5	3.0	6.0
Avg. Luminosity	$10^{34} \text{cm}^{-2} \text{s}^{-1}$	0.008	1.25	4.4	12
Beam Energy Spread	%	0.004	0.1	0.1	0.1
Higgs Production/ 10^7 sec		13,500	37,500	200,000	820,000
Circumference	km	0.3	2.5	4.5	6
No. of IPs		1	2	2	2
Repetition Rate	Hz	15	15	12	6
b^*	cm	1.7	1 (0.5-2)	0.5 (0.3-3)	0.25
No. muons/bunch	10^{12}	4	2	2	2
Norm. Trans. Emittance, ϵ_{TN}	ρ mm-rad	0.2	0.025	0.025	0.025
Norm. Long. Emittance, ϵ_{LN}	ρ mm-rad	1.5	70	70	70
Bunch Length, σ_s	cm	6.3	1	0.5	0.2
Proton Driver Power	MW	4	4	4	1.6
Wall Plug Power	MW	200	216	230	270

Gamma-gamma Collider

Gamma-gamma Collider Concept

- Based on e^-e^- collider
- But collide electron beam with laser beam just before the IP (at small angle α)
- Hard backscattered photons move almost in direction of initial electron (angle $\sim 1/\gamma$)
- Photons collide, electrons as well

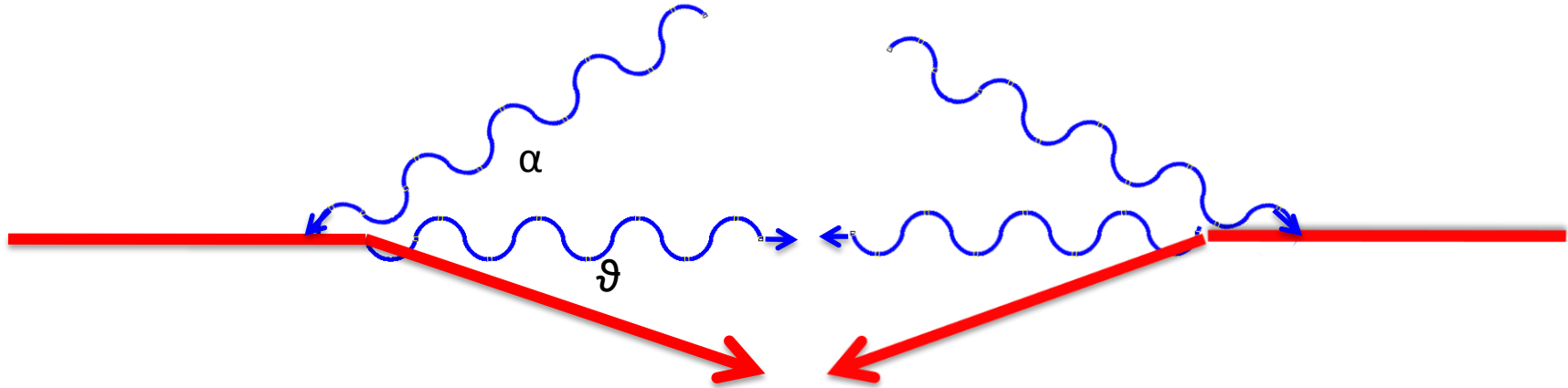

Backscattered photons form a spectrum with maximum energy given by

$$x = \frac{4E_0 \hbar \omega_0}{m^2 c^4} \quad \hbar \omega_m = \frac{x}{x+1} E_0$$

Practical maximum is 83% of electron energy

-> Typical laser wavelength $O(\mu\text{m})$, some J per pulse

Many photons are softer than maximum energy

-> Typical luminosity $O(10\%)$ of geometric e^-e^- luminosity

Plasma Acceleration

Principle Electron Driven Plasma

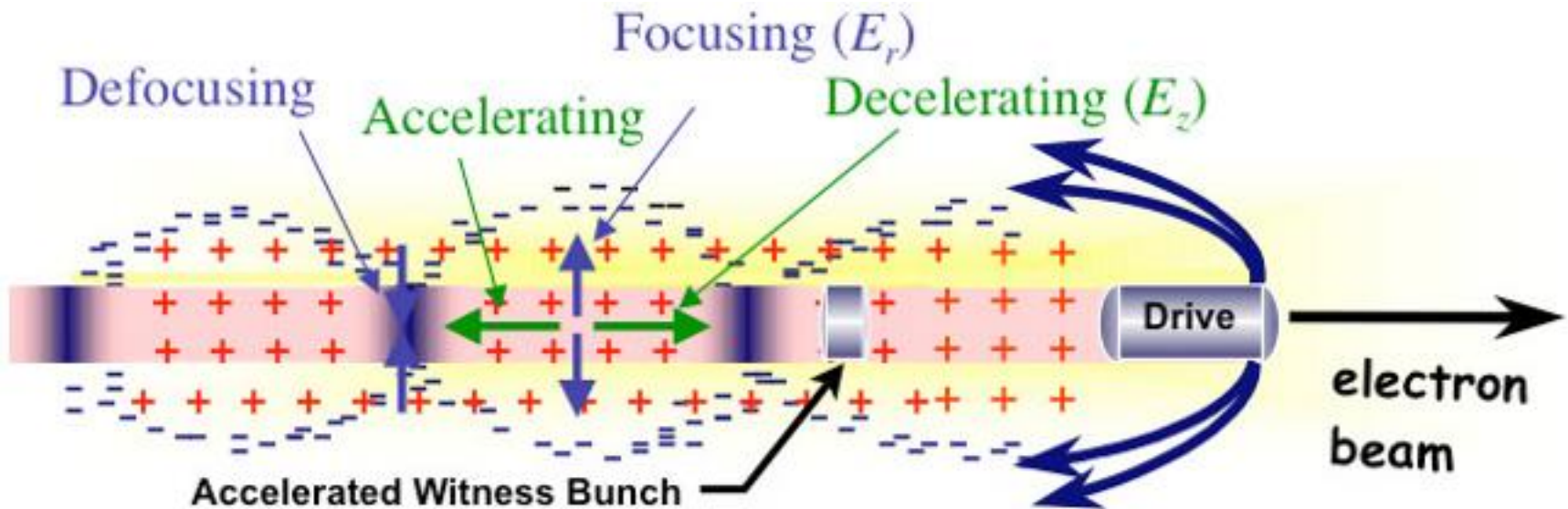

Plasma can be generated by electron beam, proton beam or laser beam

Achieved Accelerations

Using SLC beam $L=0.85\text{m}$, $G=0(50\text{GV/m})$
 $\Rightarrow 42\text{GeV}$

E167 collaboration SLAC, UCLA, USC

I. Blumenfeld et al, Nature 445, p. 741 (2007)

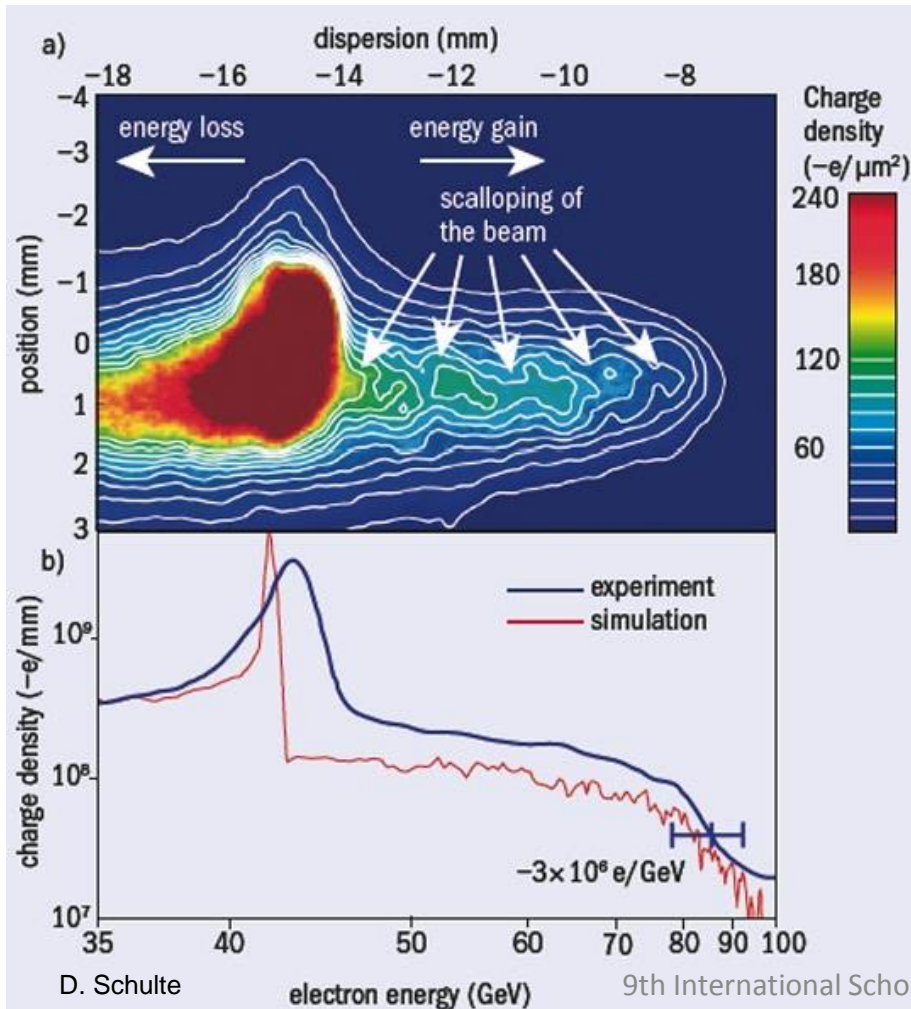

Using laser beam to generate the plasma at Berkeley
 $\Rightarrow 1\text{GeV}$

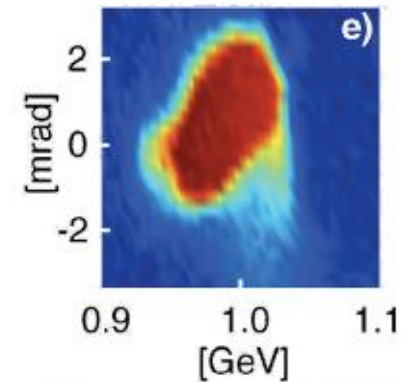

Beam energy = 1.0 GeV
Charge = $Q \sim 30 \text{ pC}$
1.6 mrad rms divergence
2.5% rms energy spread

Leemans et al., Nature Phys. (2006).
Nakamura et al., Phys. Plasmas (2007).

Laser-driven Plasma Accelerator (LPA)

Parameters from



44 March 2009 Physics Today

PHYSICAL REVIEW SPECIAL TOPICS - ACCELERATORS AND BEAMS 15, 051301 (2012)

Laser-driven plasma-wave electron accelerators

Wim Leemans and Eric Esarey

Beamstrahlung considerations in laser-plasma-accelerator-based linear colliders

C. B. Schroeder, E. Esarey, and W. P. Leemans

Lawrence Berkeley National Laboratory, Berkeley, California 94720, USA

(Received 23 November 2011; published 4 May 2012)

Surfing a plasma wave, a bunch of electrons or positrons can experience much higher accelerating gradients than a conventional RF linac could provide.

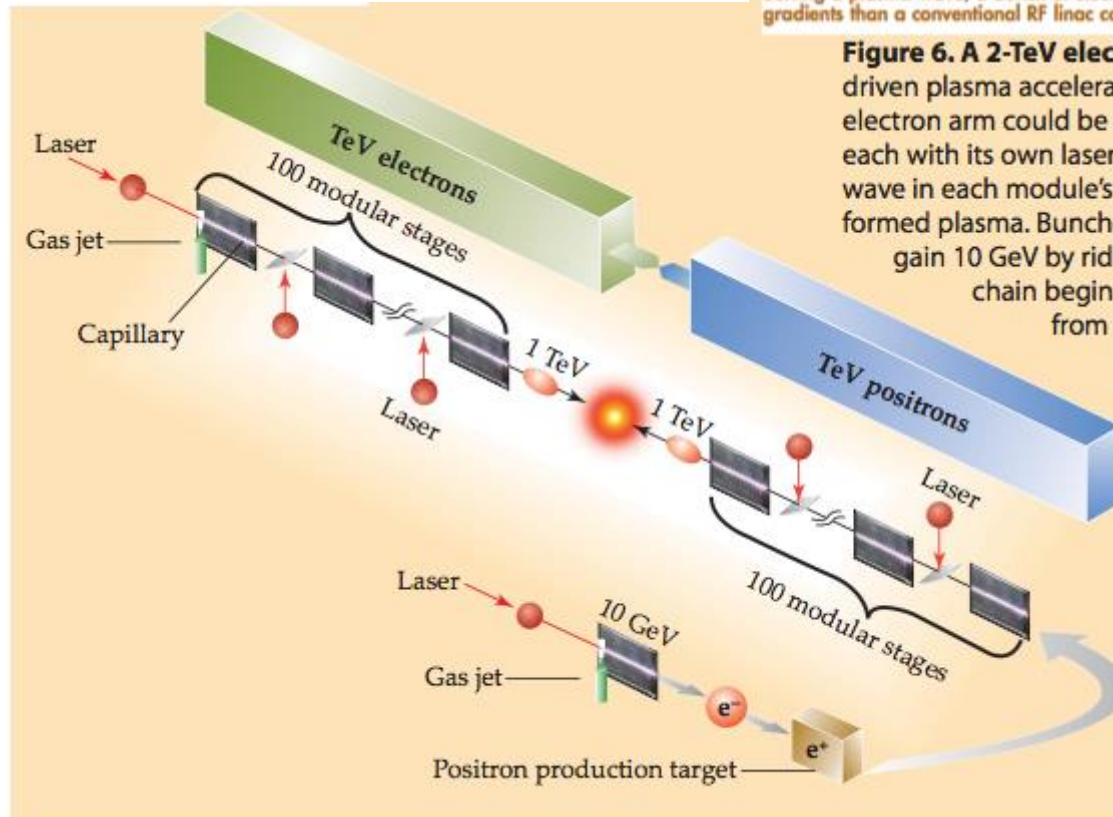
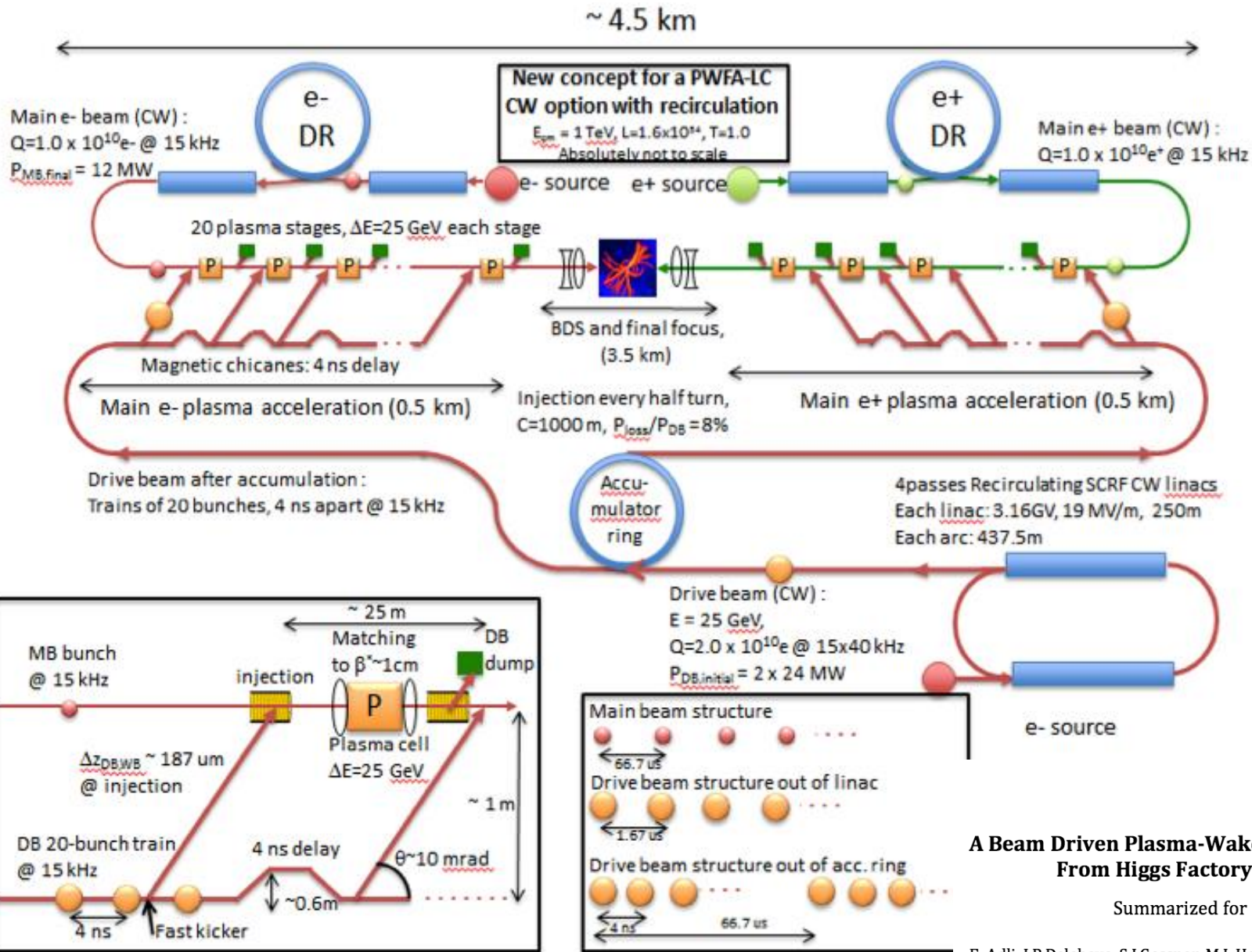

Figure 6. A 2-TeV electron-positron collider based on laser-driven plasma acceleration might be less than 1 km long. Its electron arm could be a string of 100 acceleration modules, each with its own laser. A 30-J laser pulse drives a plasma wave in each module's 1-m-long capillary channel of pre-formed plasma. Bunched electrons from the previous module gain 10 GeV by riding the wave through the channel. The chain begins with a bunch of electrons trapped from a gas jet just inside the first module's plasma channel. The collider's positron arm begins the same way, but the 10-GeV electrons emerging from its first module bombard a metal target to create positrons, which are then focused and injected into the arm's string of modules and accelerated just like the electrons.

Beam-driven Plasma Accelerator (PWFA)



SLAC-PUB-15426
[arXiv:1308.1145](https://arxiv.org/abs/1308.1145)

A Beam Driven Plasma-Wakefield Linear Collider: From Higgs Factory to Multi-TeV

Summarized for CSS2013

E. Adli, J.P. Delahaye, S.J. Gessner, M.J. Hogan, T. Raubenheimer (SLAC)
 W.An, C. Joshi, W. Mori (UCLA)

FACET at SLAC

- Drive bunch: charge $O(10^{10})$ particles, 23 GeV
 - Can use electrons and positrons
- Test of beam loading
 - 60%-90% efficiency of energy transfer
- Test of positron acceleration
- Test of plasma lenses
 - Self-focusing of the beam

<http://facet.slac.stanford.edu/>

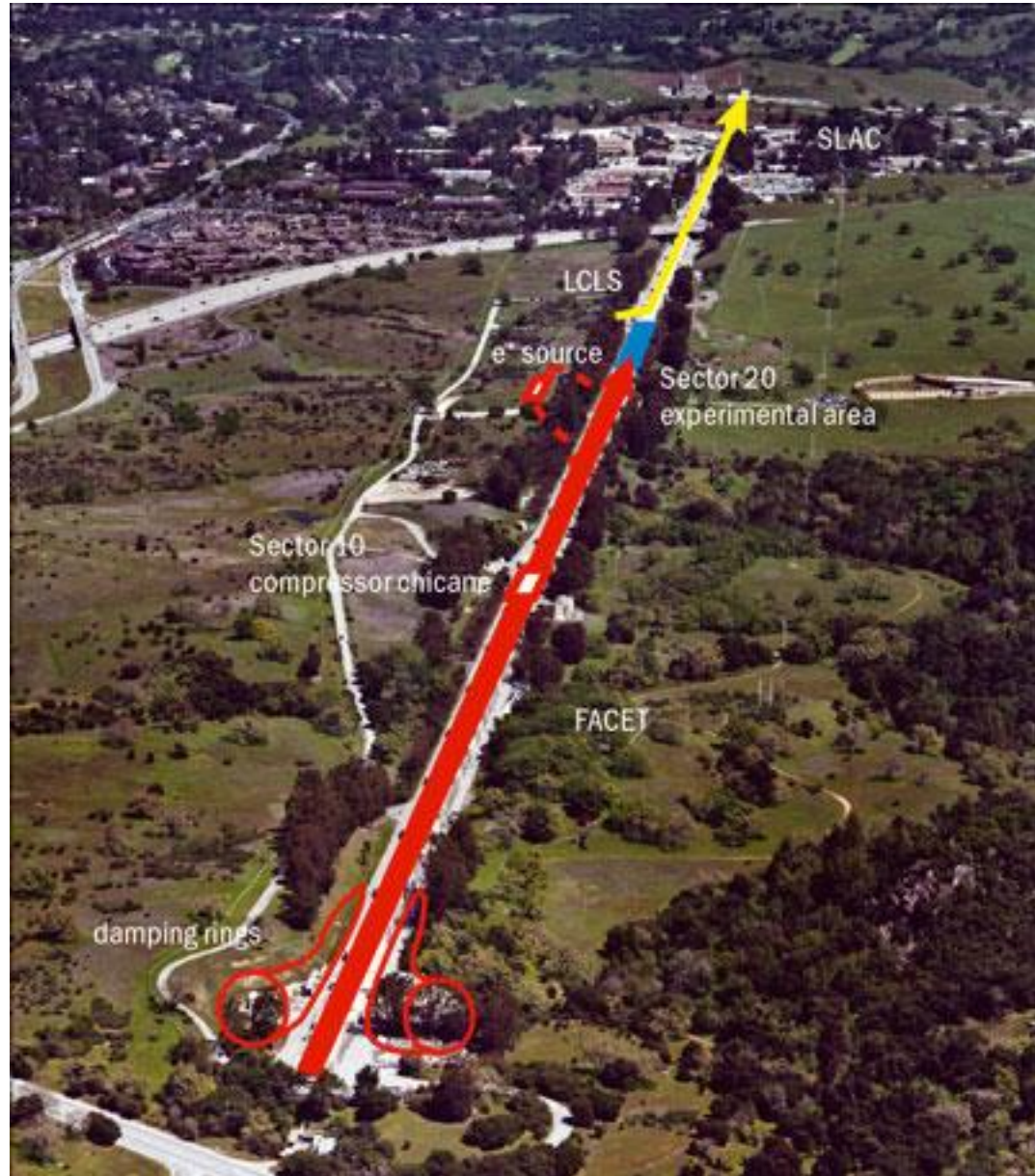

Plasma Accelerator R&D

- Use of old SLAC linac to produce electron beam for plasma generation (FACET, FACETII)
- Further development of laser-plasma acceleration in ELI (extreme light infrastructure)
 - <http://extreme-light-infrastructure.eu>
- Use of proton beam to generate plasma
 - AWAKE at CERN
- A long-term development that will take quite a while to become useful for colliders
 - Many open questions remain, e.g. beam quality, staging, ...

Conclusion

- Lepton colliders have a physics case
 - Higgs studies
 - Top studies
 - Precision studies
 - The unknown
 - Expect results from the LHC
- Linear collider can deliver high centre-of-mass energy lepton collisions
 - Technically quite mature
 - Circular electron-positron colliders have a limited energy reach (but high luminosity at low energy)
 - Alternatives (muon collider, use of plasma) require long development

Reserve

Lepton Pair Production

Colliding Photons can produce electron-positron pairs (**incoherent pair production**)

$O(10^5)$ per bunch crossing



Breit–Wheeler process

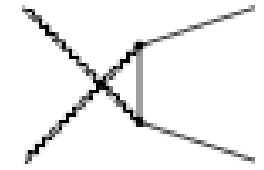
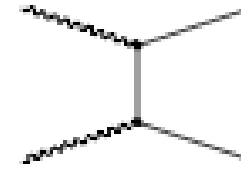

Bethe–Heitler process

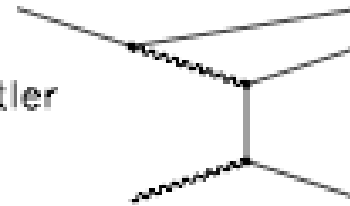

Landau–Lifshitz process

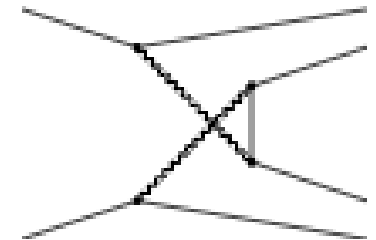
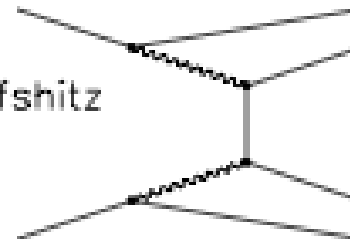

Beamstrahlung photons can turn into pair in strong field (**coherent pair production**)

$O(1-10^8)$ per bunch crossing

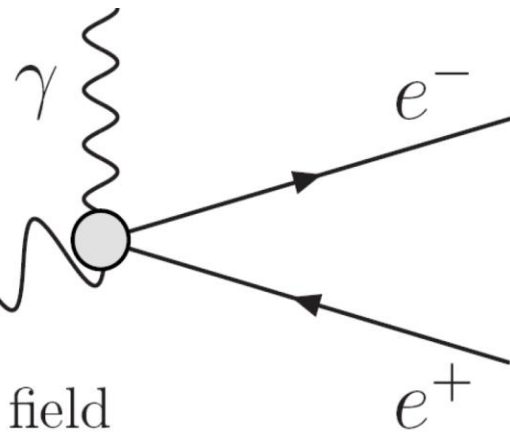

Trident cascade

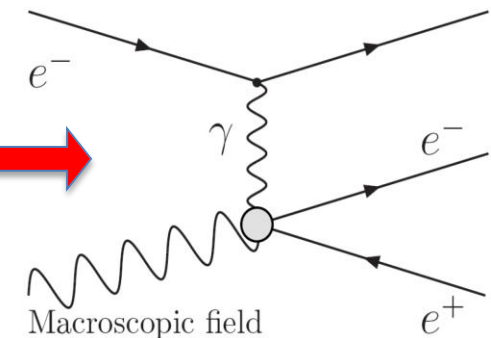

Macroscopic field

Macroscopic field

Spent Beam Content

Spent beam particles

Beamstrahlung

Coherent pairs

Trident cascade pairs

Incoherent pairs

Hadrons

...

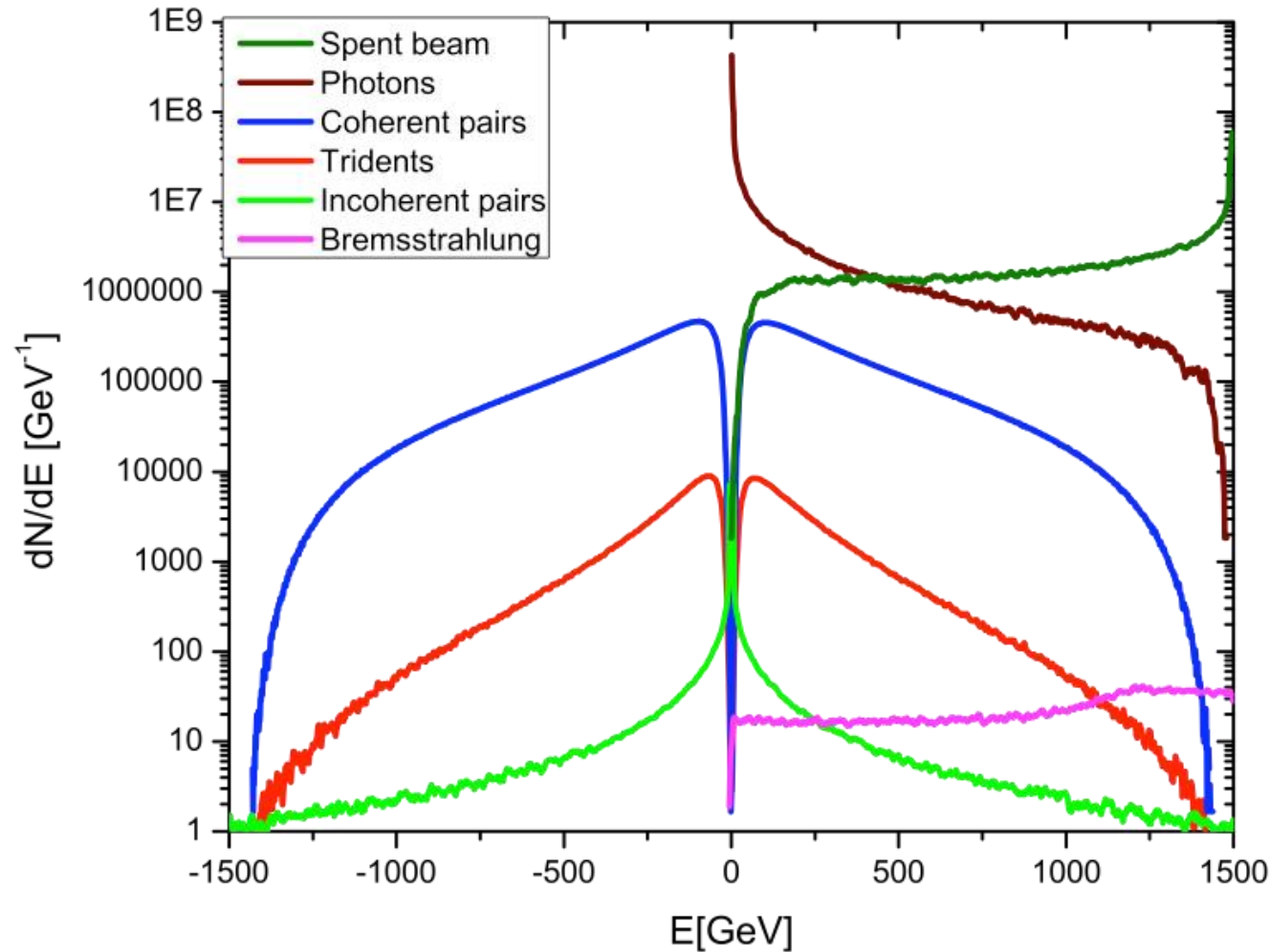

J. Esberg

Spent Beam Divergence

Beam particles are focused by oncoming beam

Photons are radiated into direction of beam particles

Coherent pair particles can be focused or defocused by the beams but deflection limited due to their high energy

-> Extraction hole angle should be significantly larger than 6mradian

We chose 10mradian for CLIC
-> 20mradian crossing angle

ILC requires 14mradian crossing angle

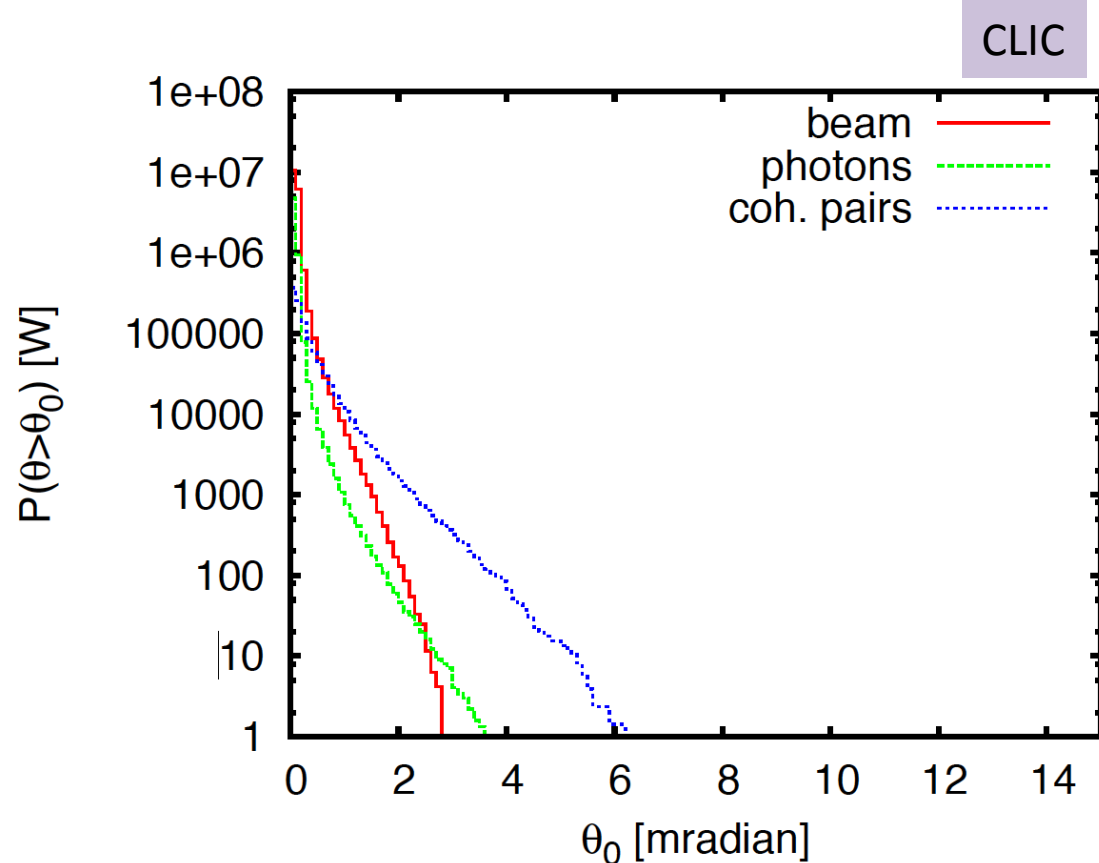
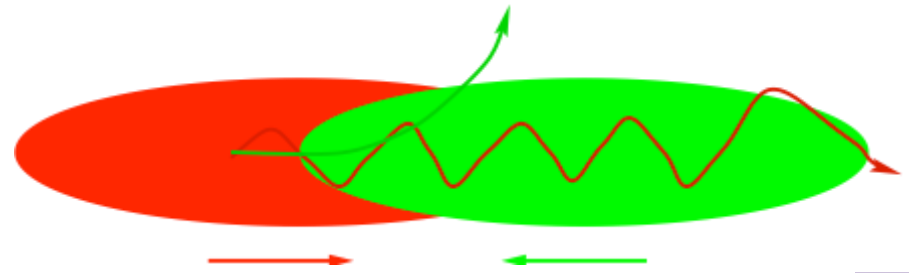

$$1 \text{ W} \approx 400 \text{ TeV/bx} \approx$$

$$300 \text{ beamparticles/bx}$$

CLIC Inner Detector Layout

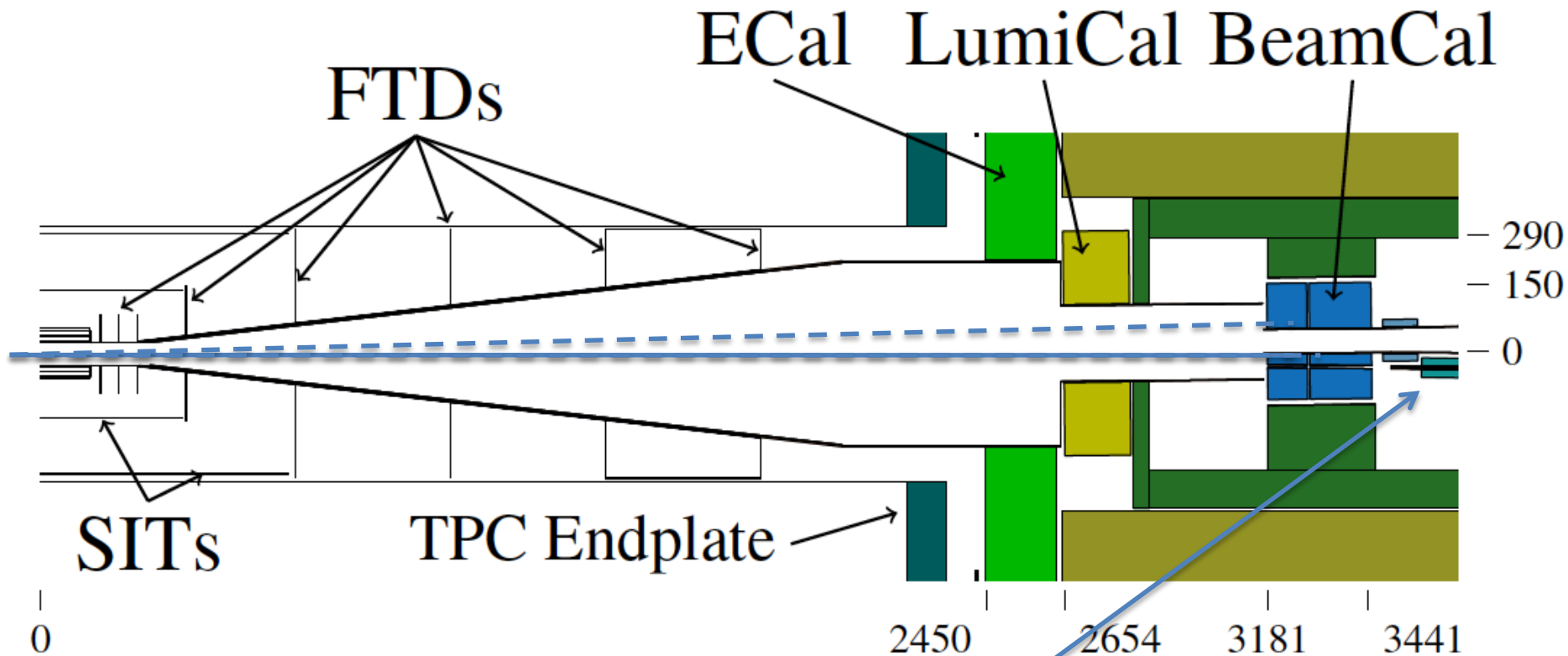

The last focusing magnet of the machine is inside of the detector

A. Seiler

Inner Detector Layout

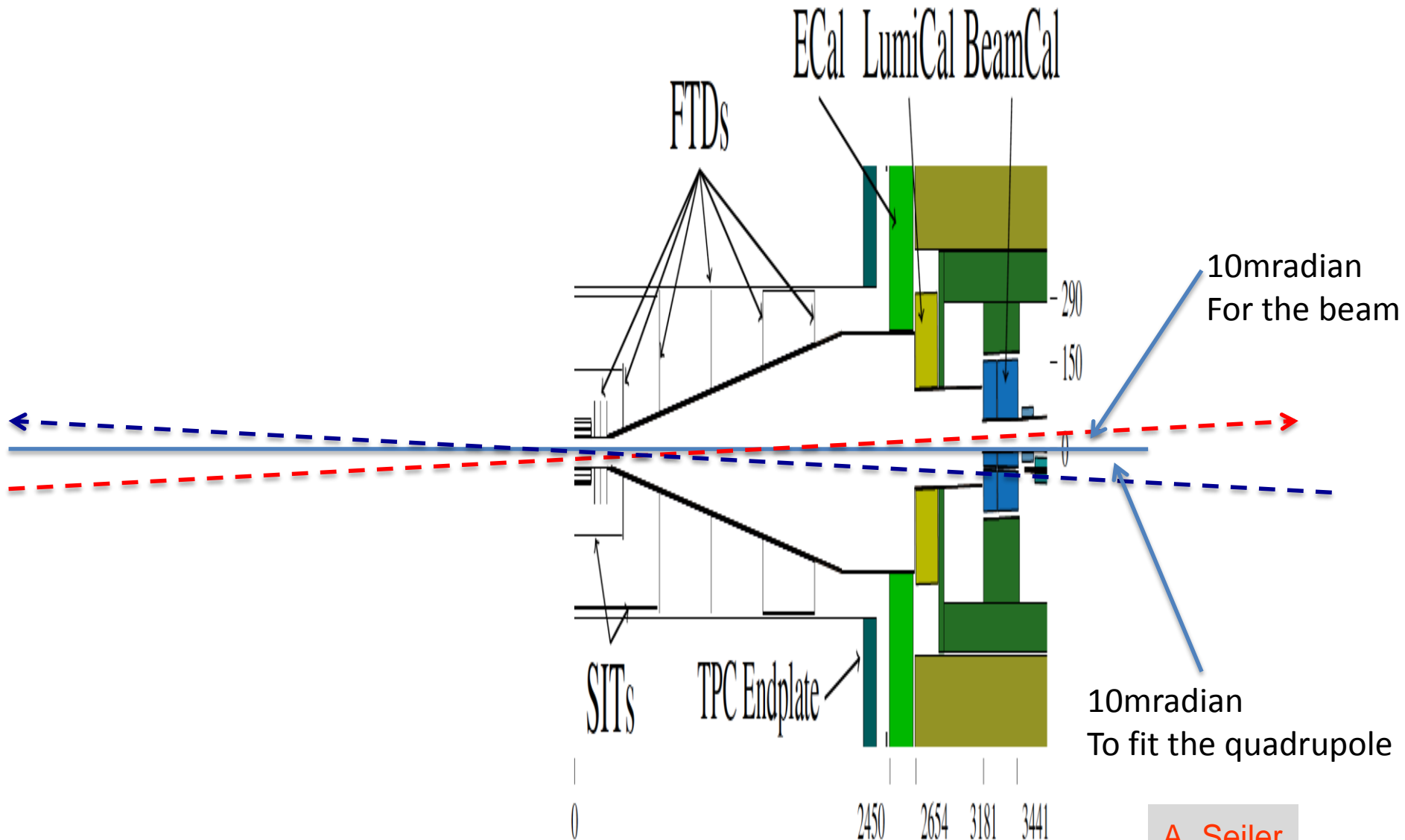

Incoherent Pairs

Breit–Wheeler process

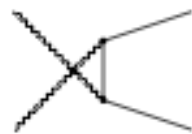
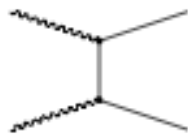

Bethe–Heitler process

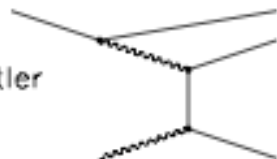

Landau–Lifshitz process

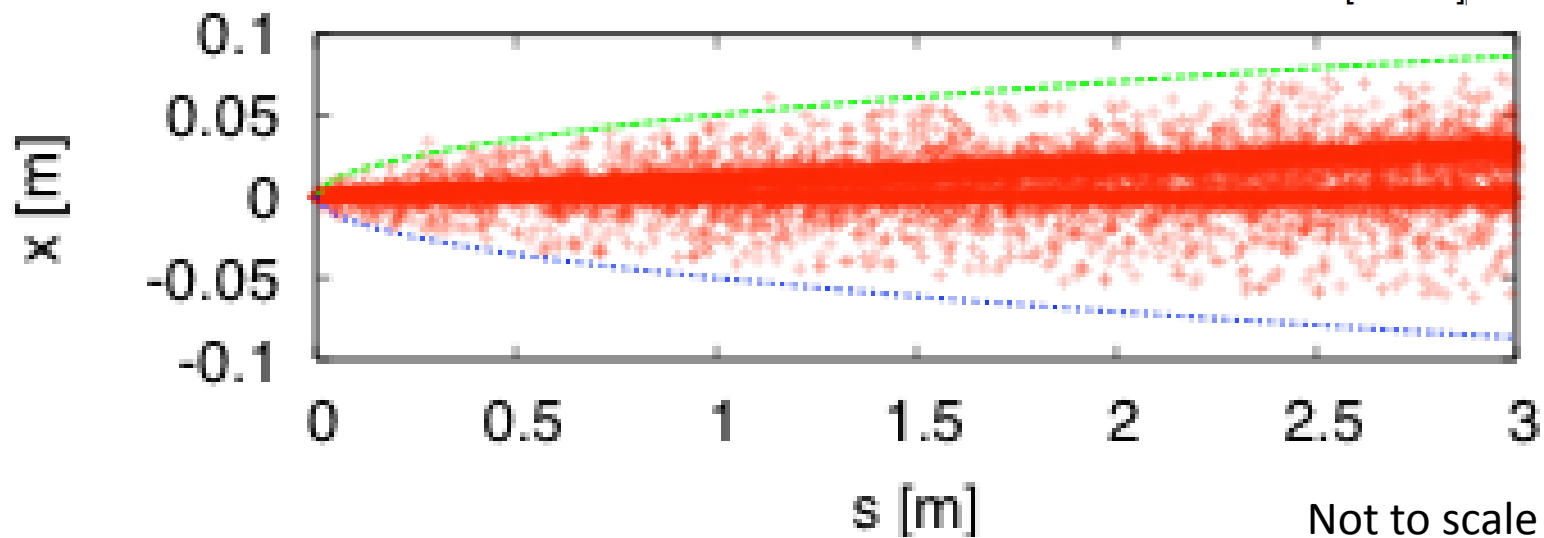
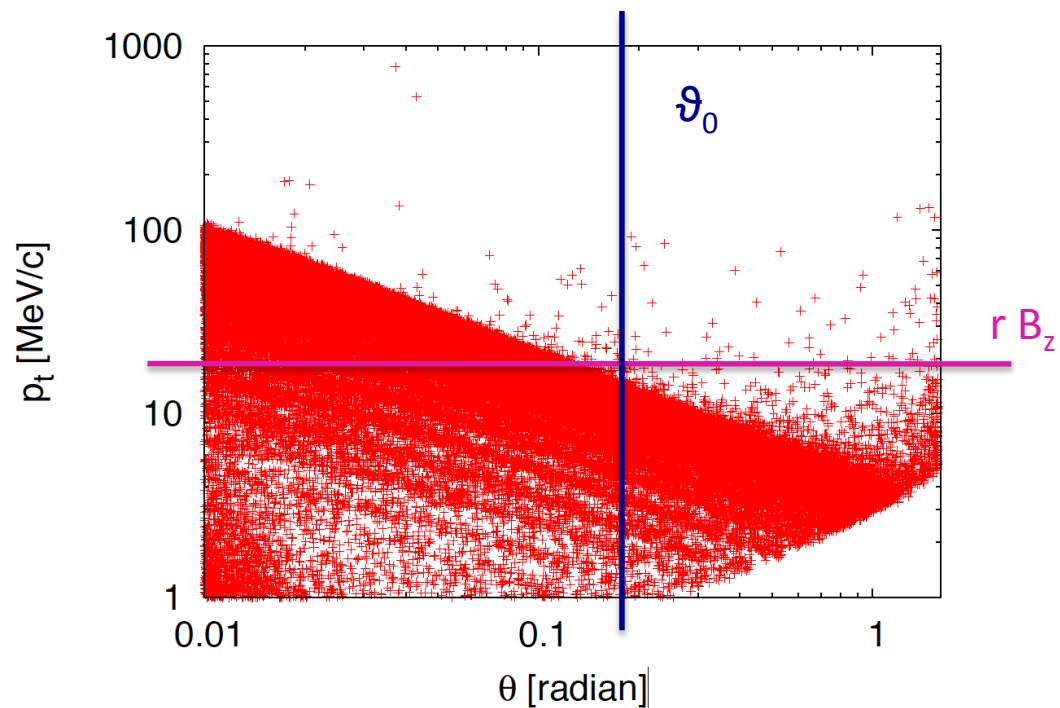
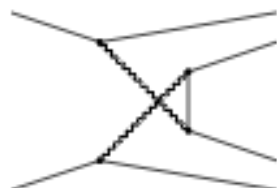
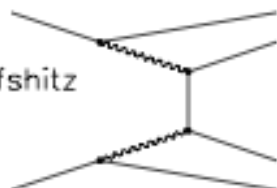

Vertex Detector Design

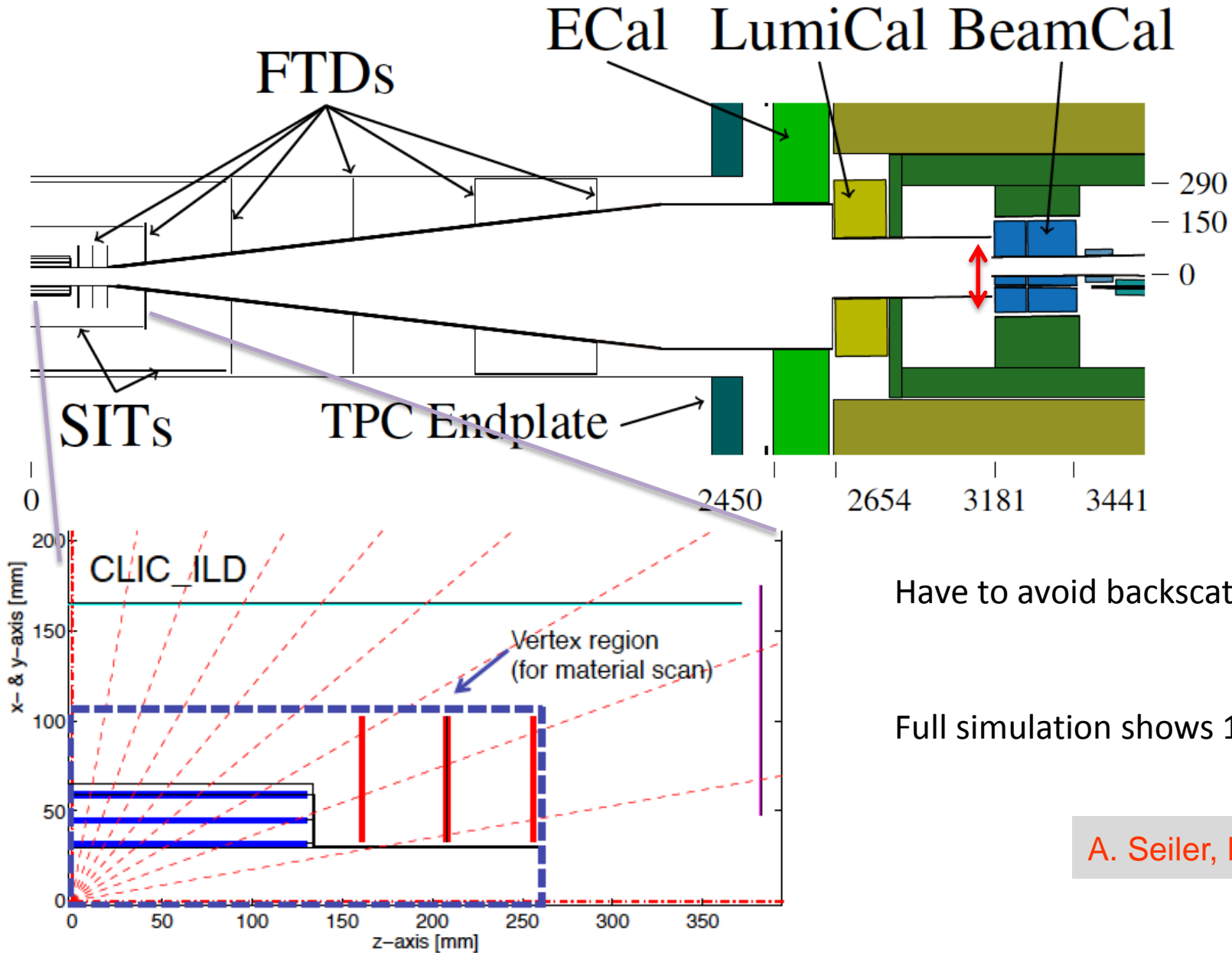

Have to avoid backscattering

Full simulation shows 1.5 hits/mm^2

A. Seiler, D. Dannheim

Hadronic Background

Only events used with

$$W_{\gamma\gamma} \geq 5 \text{ GeV}$$

Most energy is in forward/backward direction

- $E_{\text{vis}} \approx 450 \text{ GeV}$ per hadronic event
- $E_{\text{vis}} \approx 23 \text{ GeV}$ for $\theta > 0.1$
- $E_{\text{vis}} \approx 12 \text{ GeV}$ for $\theta > 0.2$
- 20% from e^+e^- (cannot be reduced)

Adds about 20% charged hits in the inner layer of the vertex detector

Can be used to monitor luminosity

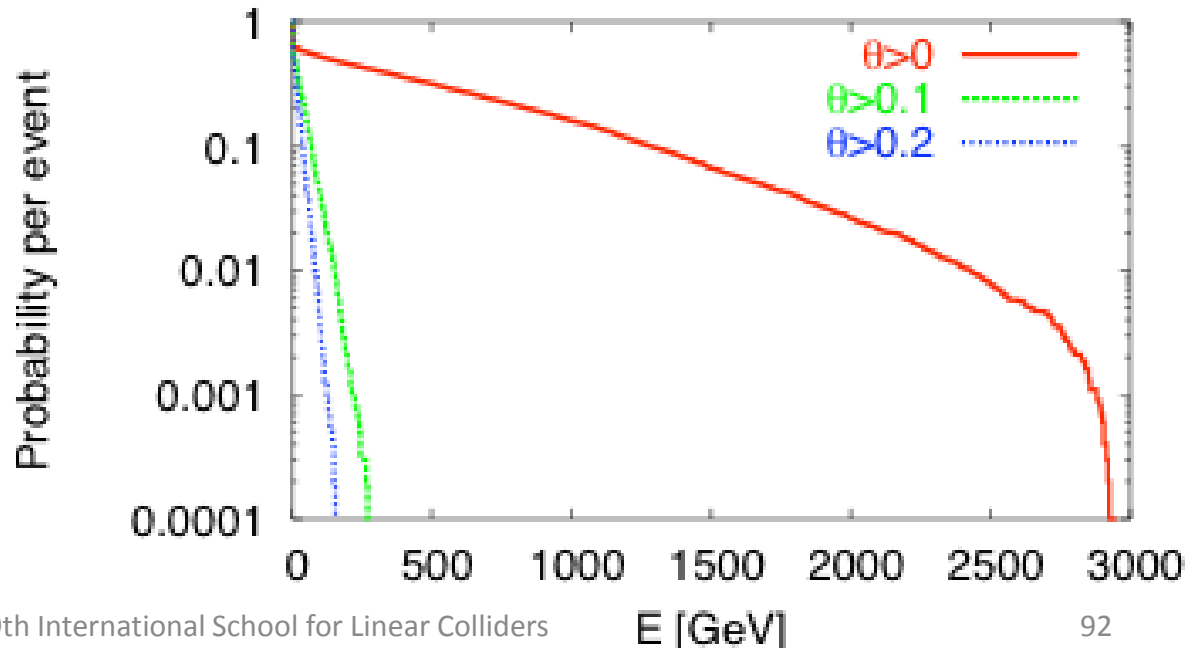
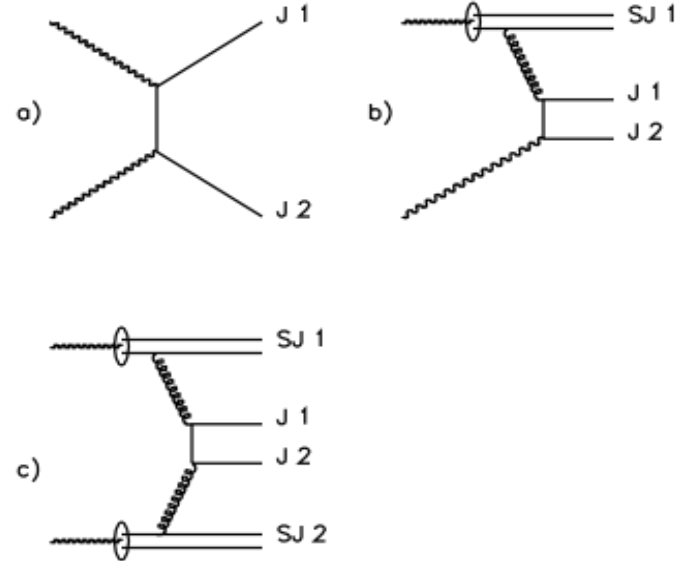

PandoraNewPFAs

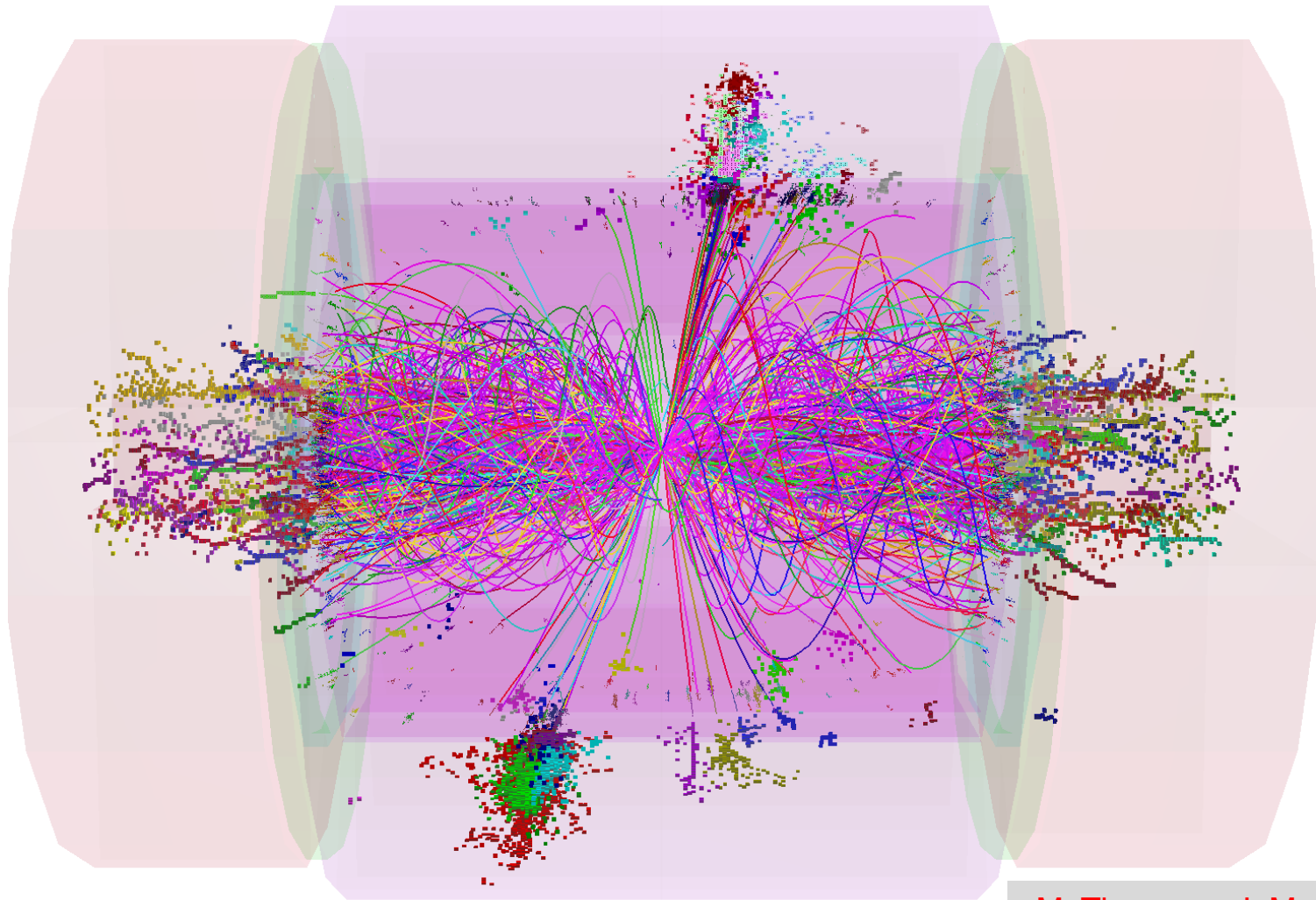

1 TeV $Z \rightarrow q\bar{q}$

1.4 TeV of background !

M. Thomson. J. Marshall

with 60 BX background

LooseSelectedPandoraNewPFAs

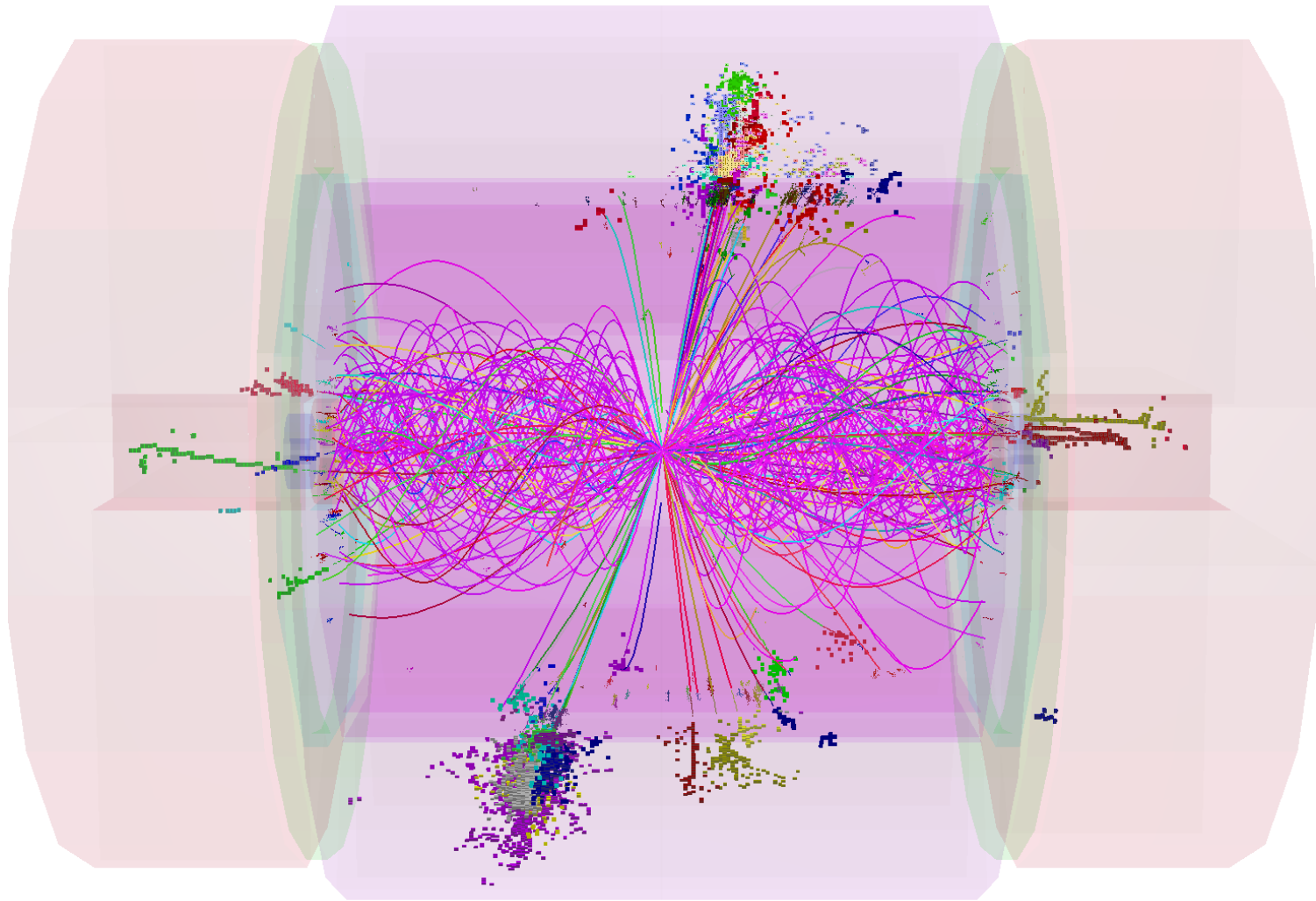

0.3 TeV of background

Selected PandoraNewPFAs

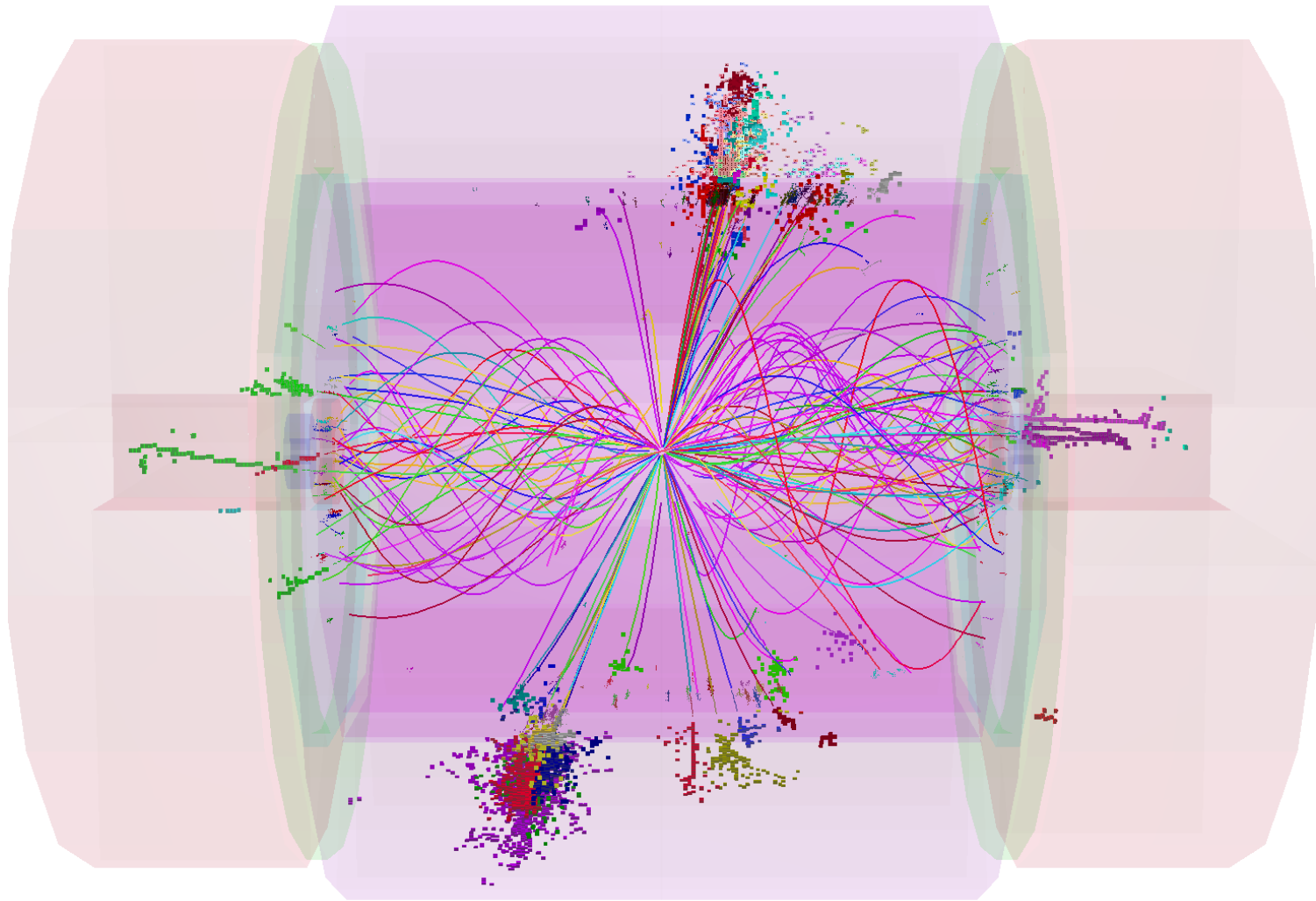

0.2 TeV of background

TightSelectedPandoraNewPFAs

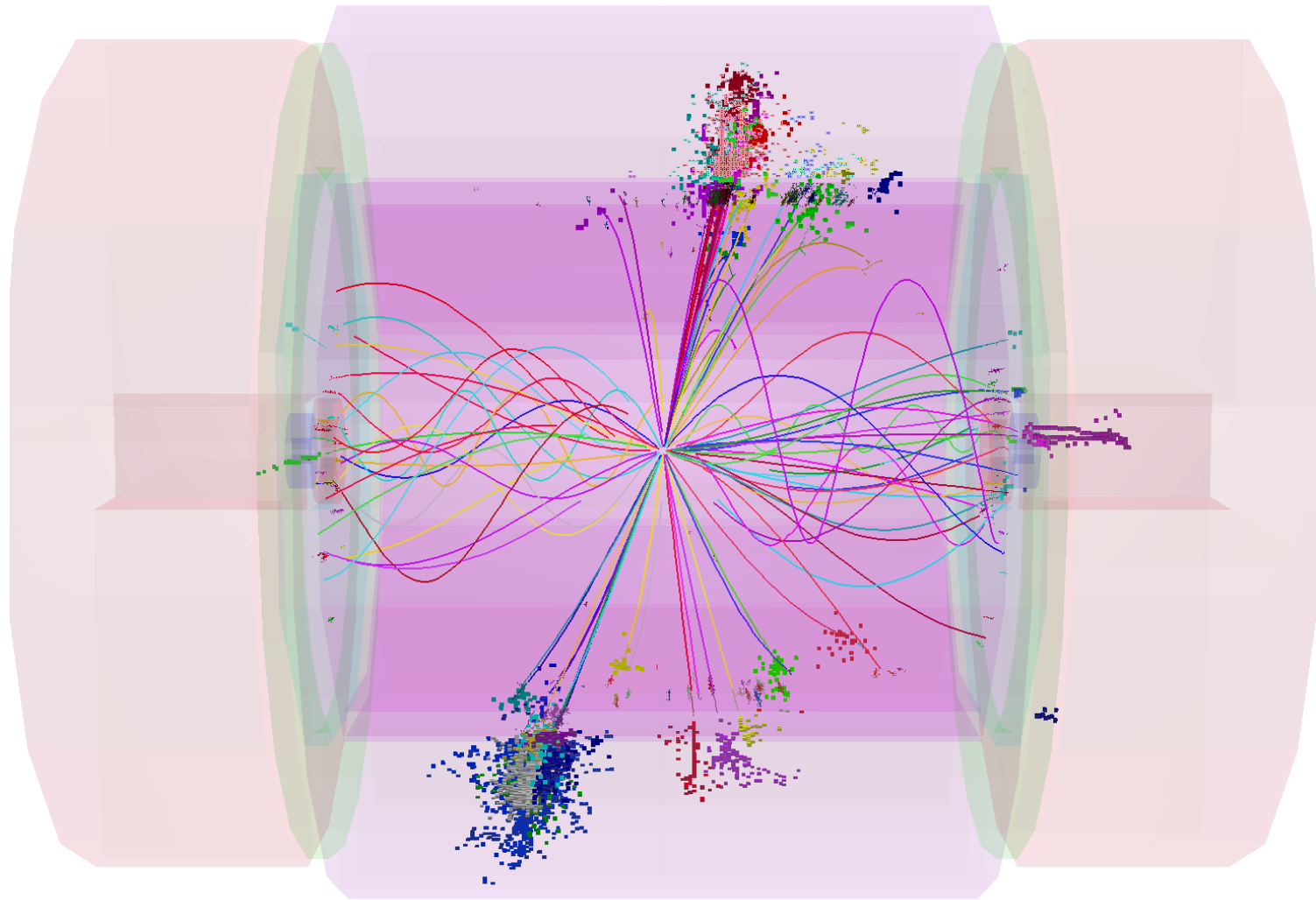

0.1 TeV of background

Impact of timing cuts on jets

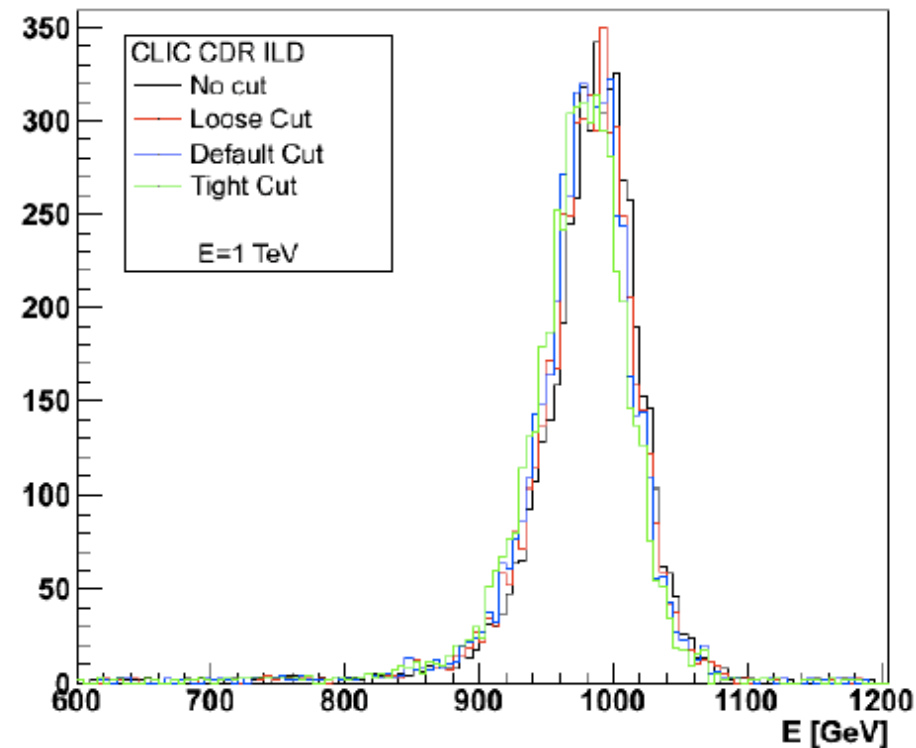
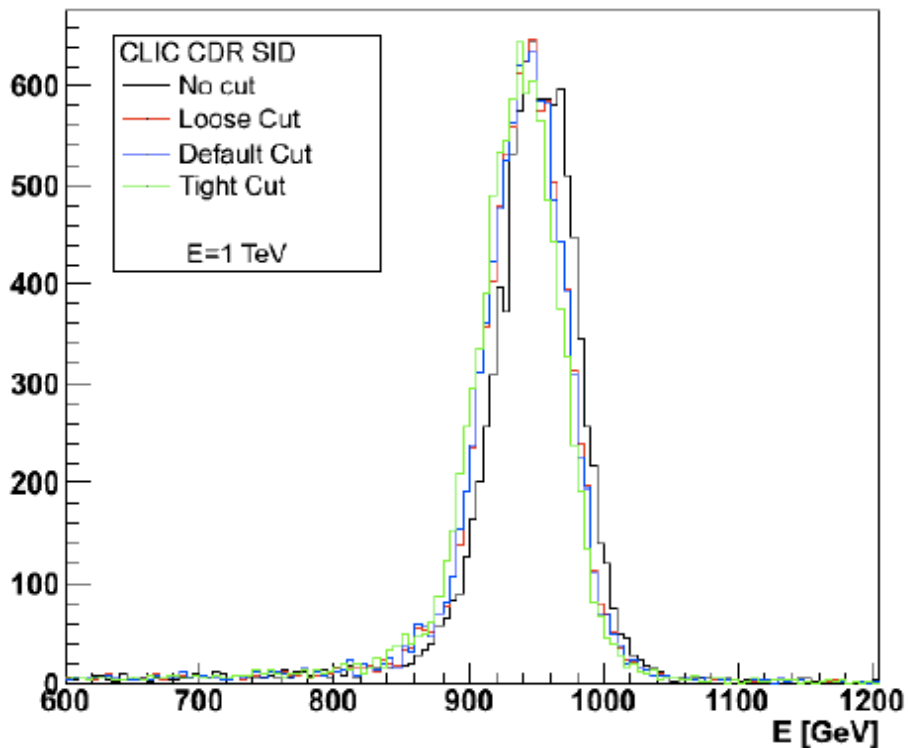

Impact of the PFOSelector timing cuts on the jet energy resolution

E_{jet} [GeV]	45	100	250	500
no cut	3.98 ± 0.05	3.15 ± 0.04	3.00 ± 0.04	3.26 ± 0.06
loose cut	4.40 ± 0.06	3.34 ± 0.04	3.08 ± 0.04	3.29 ± 0.06
default cut	5.15 ± 0.07	3.64 ± 0.05	3.17 ± 0.04	3.33 ± 0.06
tight cut	5.95 ± 0.08	3.99 ± 0.05	3.30 ± 0.04	3.37 ± 0.06

ILD

Beam-Induced Background Summary

parameter	units	CLIC	CLIC	ILC (RDR)
E_{cms}	[TeV]	0.5	3.0	0.5
f_{rep}	[Hz]	50	50	5
n_b		354	312	2625
Δt	[ns]	0.5	0.5	369
L_{total}	$[10^{34} \text{cm}^{-2} \text{s}^{-1}]$	2.3	5.9	2.0
$L_{0.01}$	$[10^{34} \text{cm}^{-2} \text{s}^{-1}]$	1.4	2.0	1.45
n_γ		1.3	2.2	1.3
$\Delta E/E$		0.07	0.29	0.024
N_{coh}	$[10^5]$	10^{-3}	3.8×10^3	—
E_{coh}	$[10^3 \text{TeV}]$	0.015	2.6×10^5	—
n_{incoh}	$[10^6]$	0.08	0.3	0.1
E_{incoh}	$[10^6 \text{GeV}]$	0.36	22.4	0.2
n_\perp		20.5	45	28
n_{had}		0.19	2.7	0.12

- **Beamstrahlung**
 - Disappear in the beam pipe
- **Coherent pairs**
 - Largely disappear in beam pipe
- **Incoherent pairs**
 - Suppressed by strong solenoid-field
- **Hadronic events**
 - Impact reduced by time stamping
- Muon background from upstream linac
 - Not discussed here

CLIC_ILD and CLIC_SiD

CLIC_ILD_CDR

CLIC_SiD_CDR

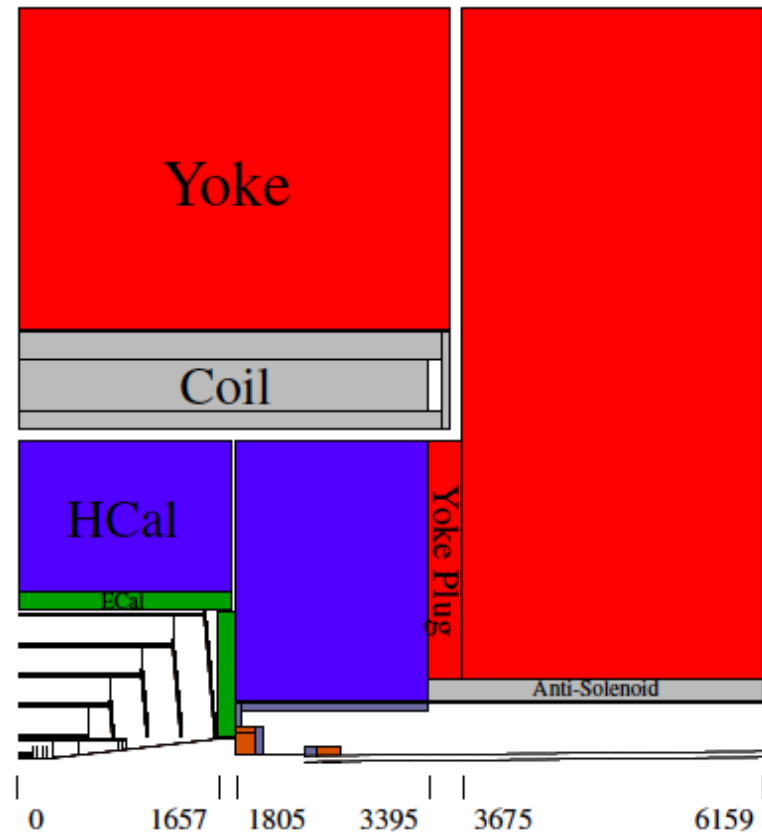
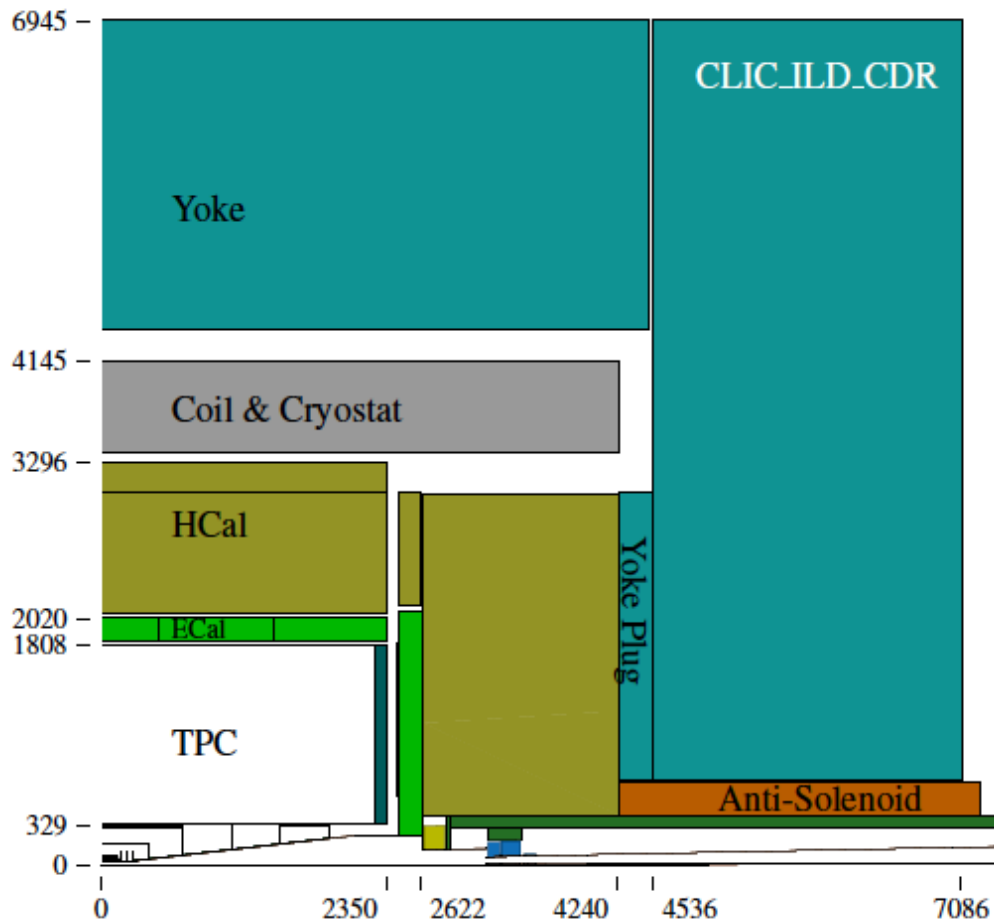

These images are derived from the simulation models for the CDR

Higgs physics 250 – 500 GeV, and above

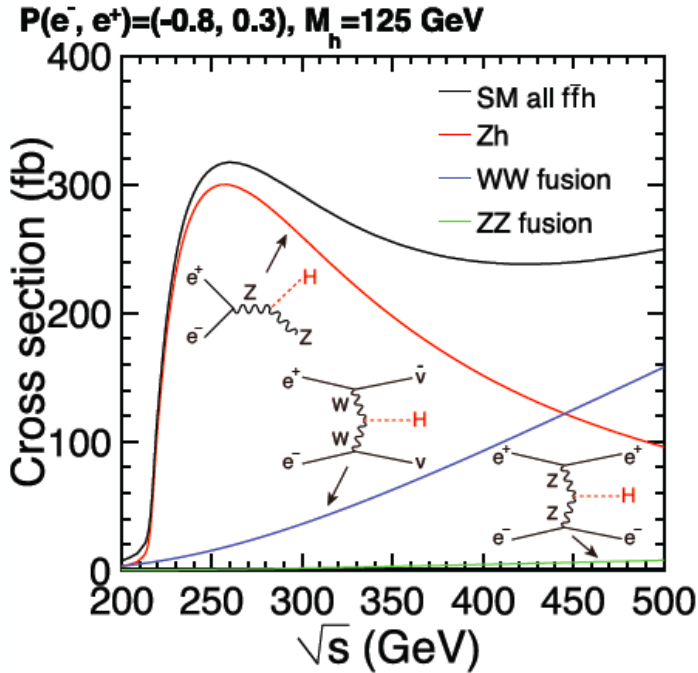

Large energy span available at Linear Colliders
 \Rightarrow access to Higgsstrahlung + WW-fusion as needed to obtain g_{HZZ} , g_{HWW} , Γ_H and a wide range of other couplings

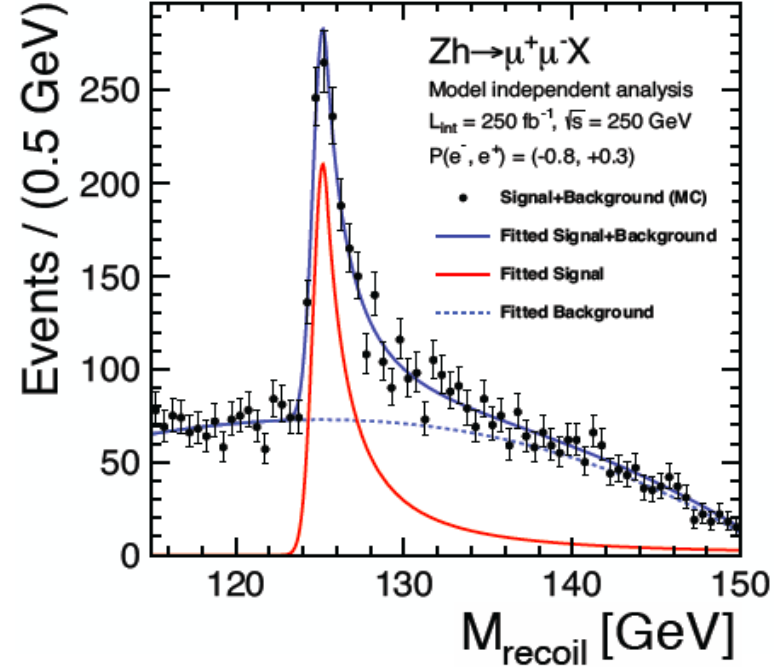

Accurate mass measurement
 best near 250 GeV
 $\Delta m_H \approx 30$ MeV

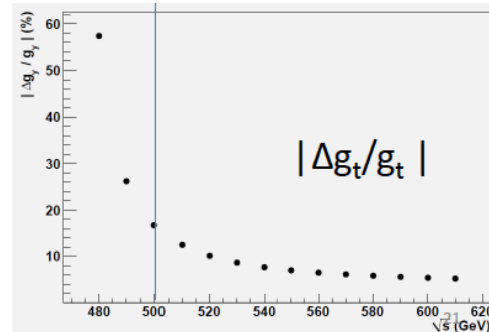
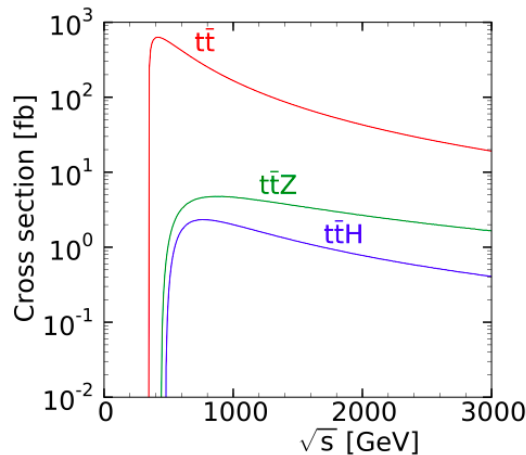

$t\bar{t}H$ threshold near 500 GeV, significant gain in going to higher energy (ultimately below 2%)

Physics beyond standard model

See talk of Monica D'Onofrio in the ICFA seminar 2014 (Searches for SUSY)

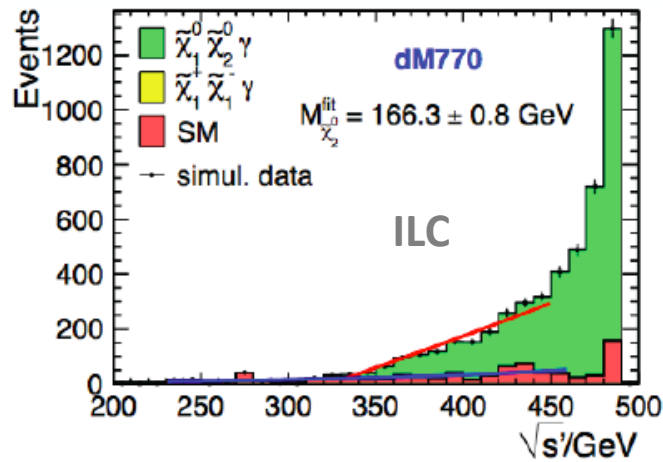
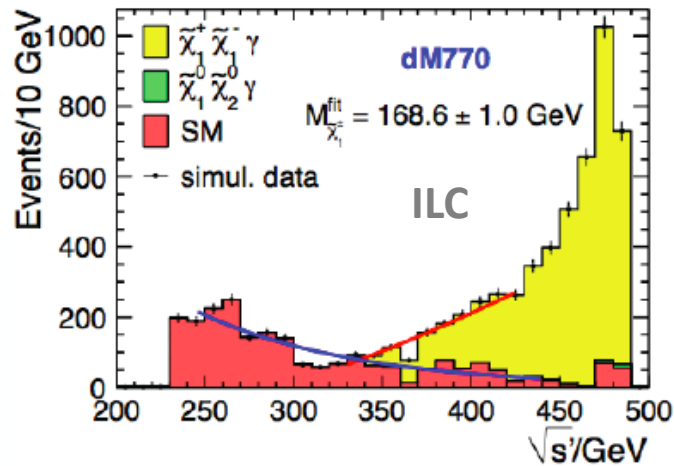

Example of ILC study:
Light higgsinos with
small mass splitting,
tagged via soft ISR
photon

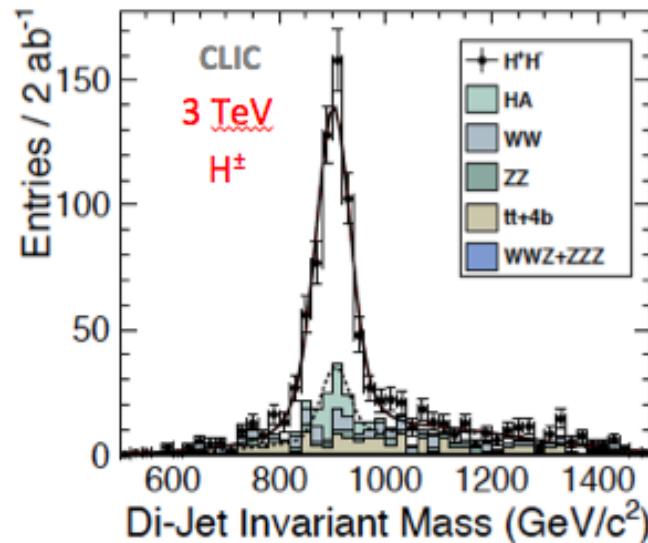
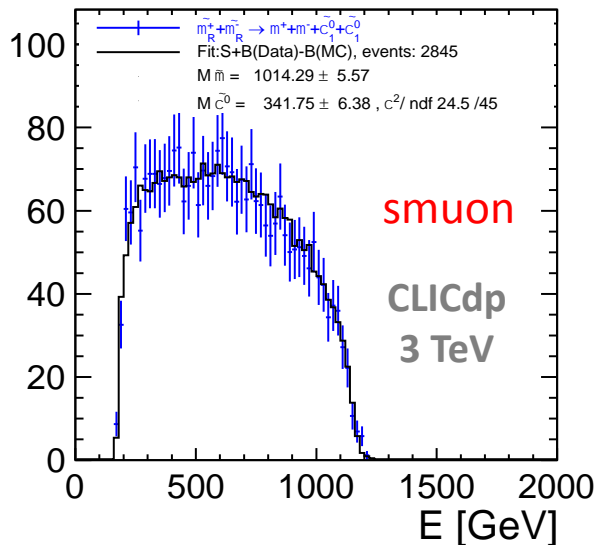

Example of CLIC studies:
SUSY particles with high
mass

- Using end-point spectrum (left)
- Reconstruction of complex multi-jet final state (right)

result: $\Delta m/m \leq 1\%$

result: $\Delta m/m = 0.3\%$