

WIR SCHAFFEN WISSEN – HEUTE FÜR MORGEN



Stephane Sanfilippo - Paul Scherrer Institut

Input slides from V. Vrankovic, C. Wouters and M. Calvi

# Magnetic measurement techniques & systems at the Paul Scherrer Institut

2nd PACMAN workshop

June 2016, Debrecen, Hungary

# Outline

- *Context : The magnetic elements of the Swiss Free Electron laser*
- *System development since 2009*
  - *Rotating coils for small aperture quadrupoles (CERN-PSI collaboration)*
  - *Hall probes: from single axis to three - axis ones*
  - *A vibrating wire system for magnetic axis measurements*
- *Specific results*
- *Future challenges*

**“Demain importe plus qu’hier”** , P. Mendes France, Député de Grenoble  
Colloque Recherche & Enseignement, Caen, 1<sup>er</sup> Novembre 1956

**Tomorrow is more important than yesterday**



**Swiss Free Electron laser: Linear Particle accelerator at PSI to produce ultrashort X-ray laser radiation pulses**

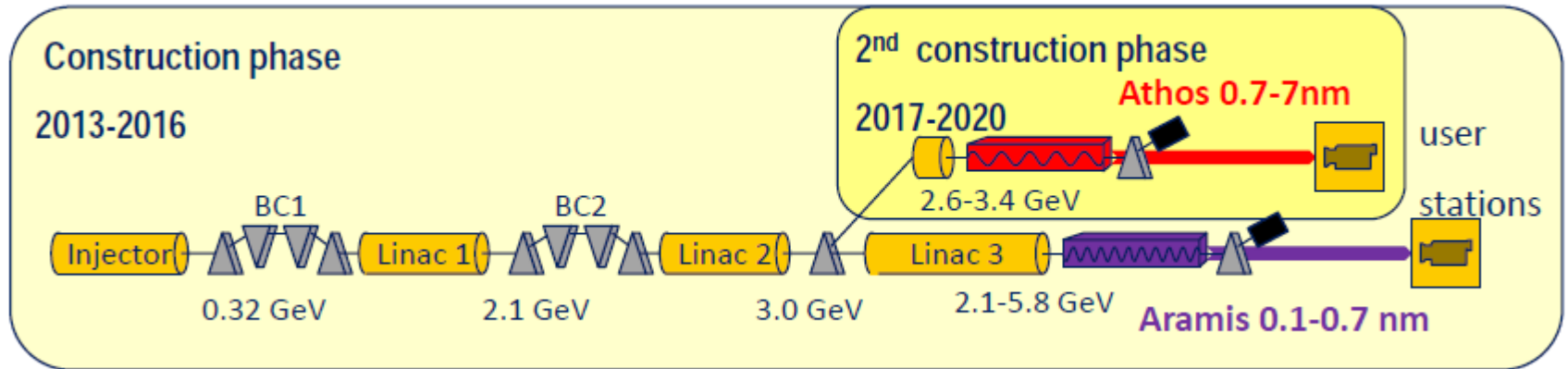

## Two FEL Beamlines:

Hard X-ray Beamline Aramis: SASE FEL (1 – 7 Å), tuning mostly by energy (2016)

Soft X-ray Beamline Athos: SASE FEL (7 – 70 Å), seeded FEL (10 – 70 Å), tuning by gap and energy (2020)

**Aramis line** : 273 magnets in total+12 in-vacuum undulators (15 mm period, 4 m long)



Guide, focus e- (low-emittance beam)



Photon production and signal amplification

Responsibility of the Magnet and Insertion Device groups (2012-2016)

Design, engineering, production follow-up, assembly and **magnetic measurements**

# The Swiss-FEL magnets (air or water cooled)

- Strengths range from 10 mT up to 1.34 T
- Lengths range up to 2 m !
- Various apertures (12 mm → 220 mm) and gaps (20 mm, 30 mm, 101 mm)
- Air cooled quadrupoles and sextupoles working at  $I_{max} \sim 10$  A

## Dipoles



(0.3 T, G=30 mm, L=0.1 m)

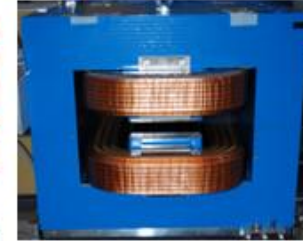

(0.5 T, G=30 mm, L=0.5 m)

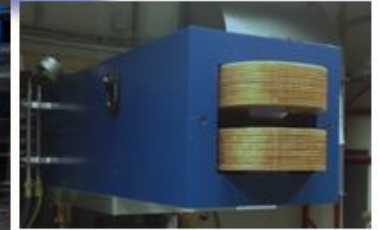

(1.34 T, G=20 mm, L=2 m)

## Quadrupoles



(50T/m  $\Phi=12$  mm, L=80 mm)



(20T/m  $\Phi=22$  mm, L=150 mm)

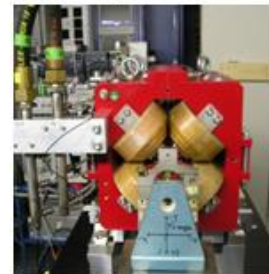

(50T/m  $\Phi=22$  mm, L=300 mm)

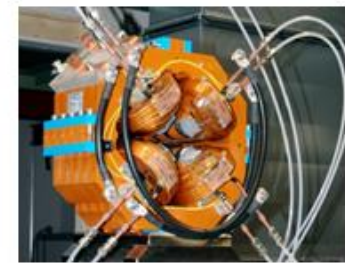

(30 T/m  $\Phi=45$  mm, L=170 mm)

## Steerers



(0.01 T, G=12 mm, L=10 mm)



(20 mT, G=80 mm, L=150 mm)

## Sextupoles



(145 mT,  $\Phi=20$  mm, L=120 mm)

## Solenoids



(0.1 T,  $\Phi=220$  mm, L=750 mm)

An amount of 220 magnets for the three linacs and the 5.8 GeV line

# The Swiss-FEL undulators for Aramis line

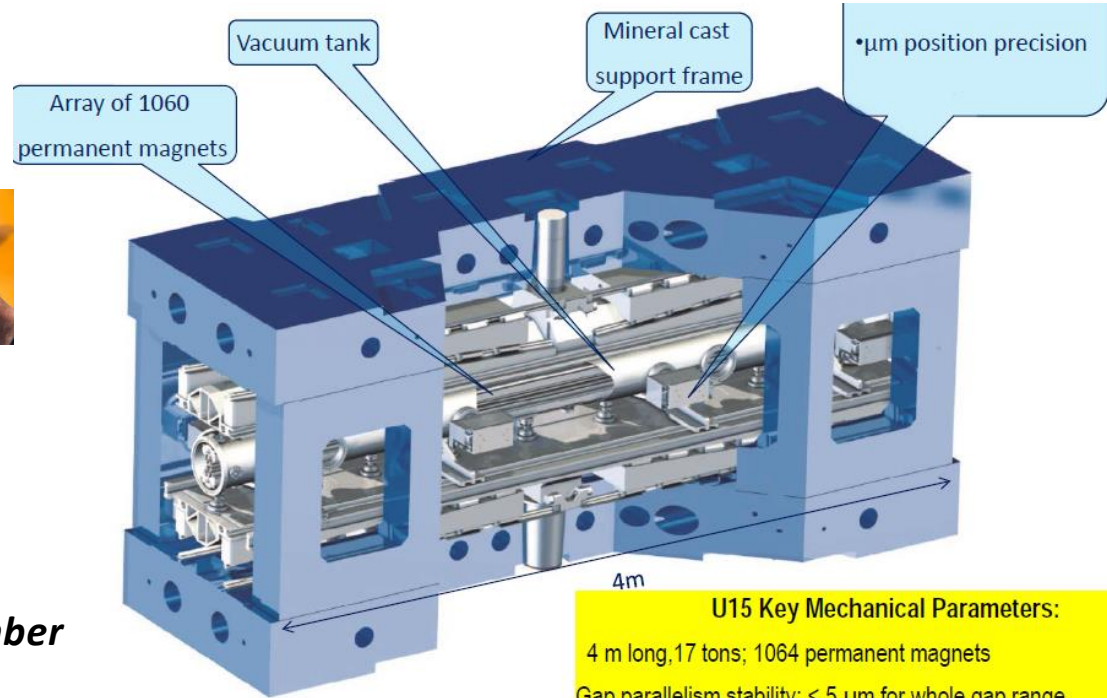

**U15 Key Mechanical Parameters:**  
 4 m long, 17 tons; 1064 permanent magnets  
 Gap parallelism stability: < 5 μm for whole gap range  
 Magnet / Pole position height: sub-micrometer shimming

**Undulator:**



**Magnetic system designed in a way that the electrons oscillate or "wiggle" along a straight line**

**In-Vacuum undulator : Magnet array inside the vacuum chamber**

Magnetic design : **Periodic** array of NdFeB magnets (1.25 T)+ CO-FE poles

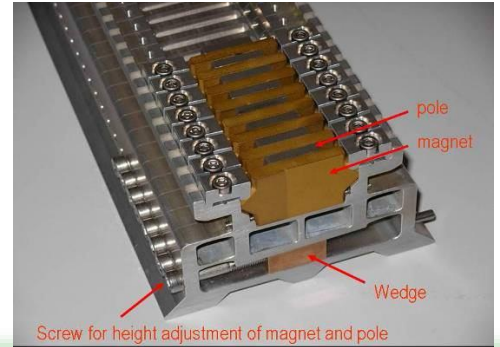
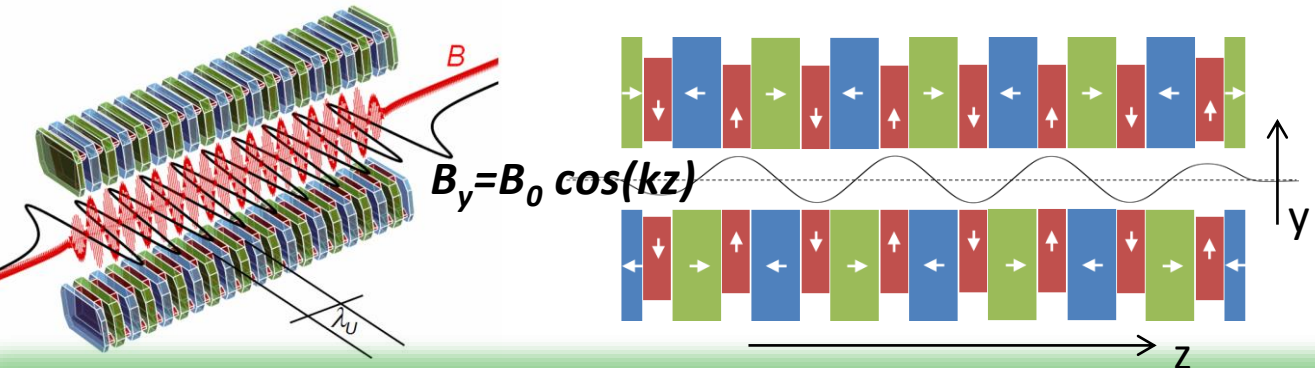

**12 modules to be magnetically characterized for the end of 2016**

## Hall Probes

- Field integrals and local fields (B vs. I curves)-effective length
- 3D Field map
- Fringe field
- Magnetic axis (solenoids)
- Field profile in undulators
- Phase errors in undulators

## Rotating coils (quadrupoles)

- Field integral vs. I curves
- Harmonics
- Alignment : Roll angle & magnetic axis stability

## Vibrating/moving wire systems

- Magnetic axis position + fiducialisation
- Thermal stability in time
- First and second field integral (undulators)



# Rotating coils

See talk of G. Severino  
for the measurement technique  
and fabrication

**Goal : Measure the field integral, the multipoles and  
the roll angles of the small aperture quadrupoles ( $\varnothing=12\text{mm}$ ,  $\varnothing=22\text{ mm}$ )**

## CERN "linac 4" coil ( $\varnothing=19$ mm)

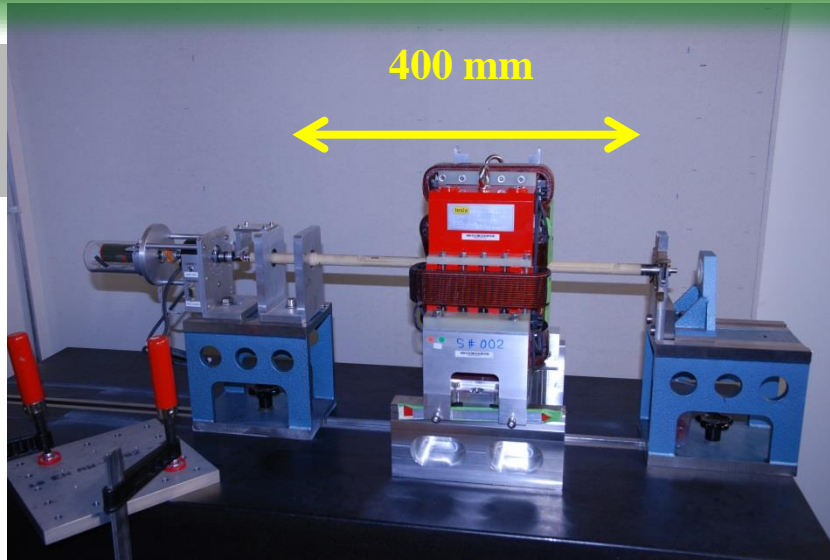

## CERN PCB coils ( $\varnothing=8$ mm)

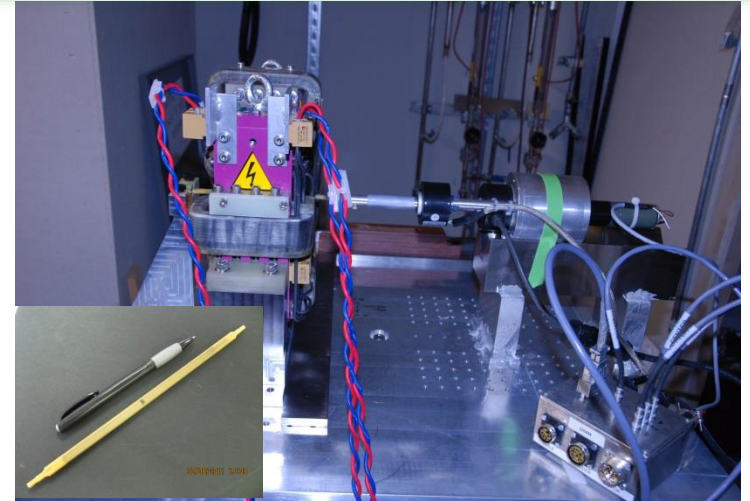

### 3 tangential coils to reject dipole and quadrupole components ((b1 and b2 bucking))

- $\varnothing 19$  mm x **400 mm** coil head
- "On body" winding technique: windings directly on a precisely machined rotating support
- Measurement radius: 8 mm
- 100 and 64 turns/coil
- **In situ calibration**

- $\varnothing 7.8$  mm x **150 mm** coil head
- Coils : Monobloc PCB technology
- Measurement radius: 3 mm
- 3 coils: 200, 100 and 200 turns
- **In-situ calibration (ref-Hall probe)**

	Field gradient (+/- 10 A)	Multipoles (10 A)
Accuracy (ref: Hall probe)	0.15 %	
Reproducibility	<0.05 %	0.02 %

**OK for our  
magnets**

**(PSI-CERN- collaboration, at the PSI since march 2012)**





# Hall probes

From one axis to three axis



# The hall effect in a nutshell

Electron and hole conduction:

$$\left. \begin{array}{l} \mu_n \neq \mu_p \\ \text{or} \\ n_n \neq n_p \end{array} \right\} V_H = G \frac{R_H}{t} IB$$

$$R_H(B, T), G\left(\frac{l}{w}, B\right)$$

$l \gg w$ , cruciform:  $G \approx 1$

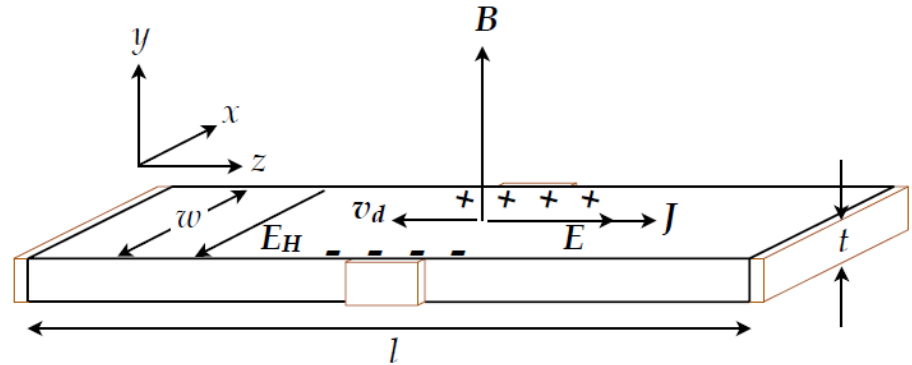

Hall effect in an n-type semiconductor

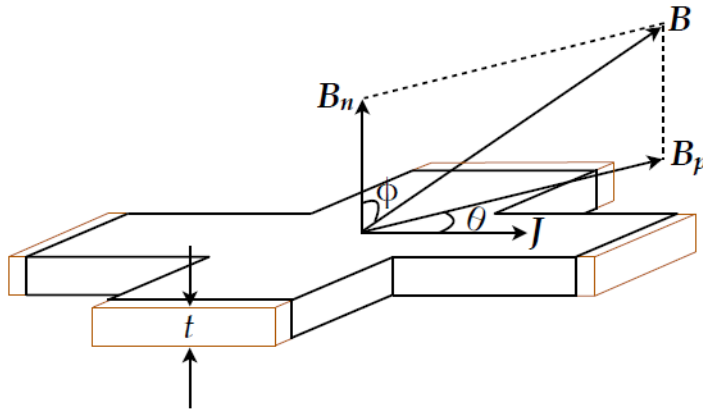

Planar Hall effect

$$V_{out} = V_H + V_{PH} = \frac{R_H}{t} IB_n + \frac{R_{PH}}{t} IB_p^2 \sin 2\theta$$

$$V_{PH} = \frac{R_{PH}}{2t} IB_p^2 \sin 2\theta$$

if  $R_{PH1} = R_{PH2}, B_{p1} = B_{p2}, |\theta_2 - \theta_1| = 90^\circ$ :

$$\frac{1}{2}(V_{PH1} + V_{PH2}) = 0$$

**PHE, Hall Planar effect**  
**Double angular dependence**

- Sensitivity depends on carrier concentration & sensor geometry
- Temperature dependence of the Hall coefficient
- Periodic calibration  $V=f(B)$  needed
- B sensing accuracy depends on the field orientation vs. active area

**Courtesy Ch. Wouters**  
**(Ph.D defense 2016)**

# Hall probe measurements

## Pro

- Field mapper for the main field component;
- high accuracy field measurement for computing K, trajectory, phase error (undulators)
- Broad magnetic field range (mT to few T),
- Field integrals by numerical integrations
- Can be inserted in narrow apertures (magnets, undulators) ;
- Work in non-homogeneous field
- Can be used for low temperature measurements;
- Medium accuracy for single component measurement ( $\sim 0.01\%$ ), resolution  $\sim 0.3$  G;
- Easy to use, easily portable/moved;
- Inexpensive, big market;
- Easy element to integrate in a electronic circuit;

## Cons

- Temperature sensitivity
- Non linearity  $V=f(B)$  to be corrected
- Offset to be compensated
- Drift of offset, Non Linearity and temperature sensitivity with time;
- Planar hall effect; To be compensated for accurate (below 0.1%) three axis measurements
- Calibration (delicate for multi axes sensors)
- Do not deliver harmonics
- Not ideal for magnetic axis measurements
- Time consuming for integral measurements

Hall probe lab. of the Magnet Section exists for over 30 years

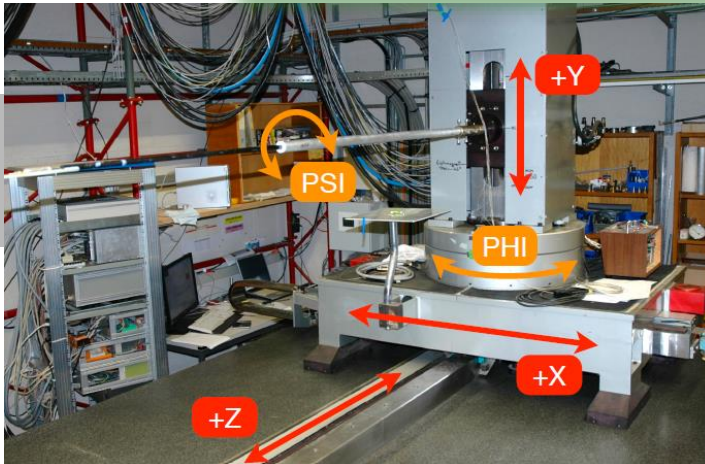

(5-axis machine, moving on air pads, flying mode measurement)

## 1<sup>st</sup> Major upgrade for the SwissFEL magnets: Multi-probes for quadrupole field mapping

- multiple Hall sensors (1D) on one arm
- water levels integrated in measurement arms

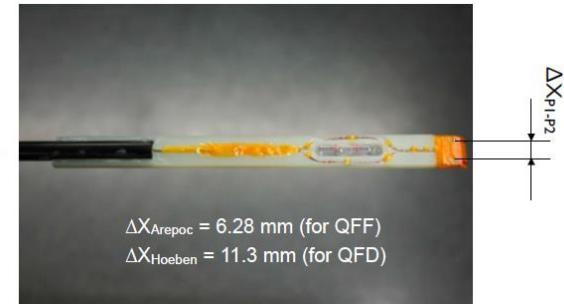

## Compact system for the small aperture quads

- Direct measurement of the field gradient
- Constant  $\Delta X \rightarrow$  corrects for position errors:
  - due to arm vibrations
  - magnet misalignment

Transverse Hall Probe	Siemens SVB 601S1
Semicond. material	InAs
Active area	2.6 mm <sup>2</sup>
Sensitivity	60 mV/T
Hall Probe absolute accuracy	10 $\mu$ T
Hall probe resolution	1 $\mu$ T
Maximum calibrated Field	3.1 T
Non linearity (0-1T)	<0.2 %
Temperature sensibility	70 ppm/°C

- Accurate measurement in the main direction  
(**1 D probe**)
- System dedicated to dipole measurements

## Hall probe system for the U15 Swiss-FEL undulators measurements

Three components of magnetic field needed

→ Use of a three-axis Hall probes

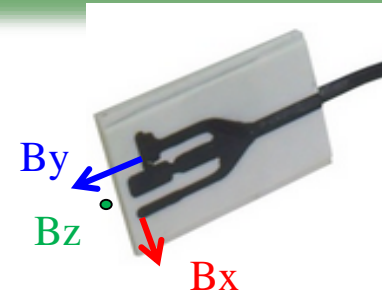

Epitaxial grown  
ceramic support

Hall Probe "S"  
from SENIS

## Step 1: Magnetic optimization (ex vacuum)

- Measurement **w/o the vacuum chamber**
- **Automatic screw driver for corrections**
- Shimming based on Hall probe trajectory and phase error measurements.



## Step 2: In- vacuum optimization

- Dismounting of the out-vacuum beam-out vacuum shafts-PM array;
- Insert the vacuum chamber/ PM array;
- Hall Probe measurements & adjustments

**PSI : Integrated systems using a 3D Hall Probe  
for out and in-vacuum measurements and corrections  
Inspired from SAFALI ( Tanaka-Spring 8)**

**Ex-vacuum**

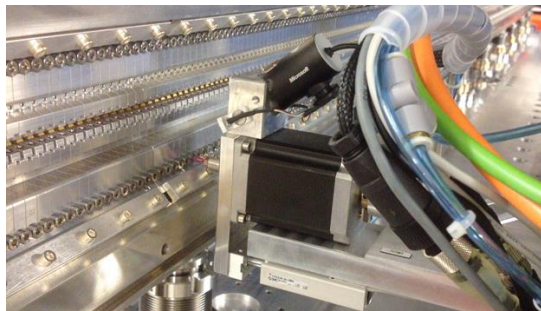
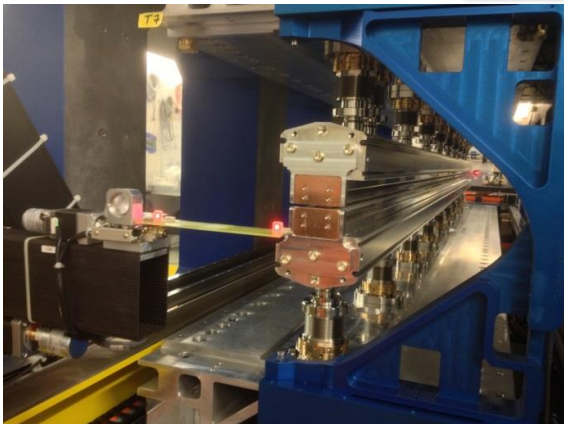

**Optimization with an  
automatic controlled screw driver**

**In-vacuum**

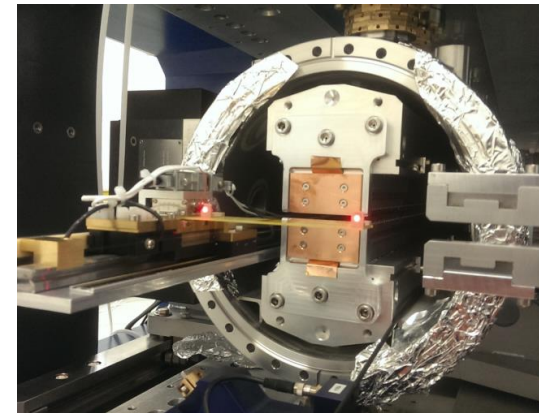

## Measurement w/o vacuum chamber

- Measure the magnetic field along the undulator with the hall probe bench:
- $B_z(s)$ ,  $B_x(s)$  and  $B_y(s)$
- Measure the first and second field integral with the moving wire in z and x direction:

$$I_{1z}, I_{2x} \text{ \& \ } I_{1z}, I_{2x}$$

- **Calibration**  $\int B(s)ds = I1$   
 $\int \int B(s)dsds = I2$

- **Shimming** : Calculate the Trajectory and Phase
  - ✓ Estimate the correction both in z and y:
  - ✓ Apply and repeat the correction with the **columns** and **robot screw-driver (height adjustment)** till
    - $I1 \sim 0$ ;  $I2 \sim 0$
    - Phase error  $< 10^\circ$

## Measurement with the vacuum chamber

- Measure the magnetic field along the undulator with the hall probe bench:  
 $B_z(s)$ ,  $B_x(s)$  and  $B_y(s)$
- Check the Trajectory and Phase
- Correction by moving up/down the 20 out-vacuum shaft to compensate the errors from the I-beam movement



# Three axis Hall sensor- brief reminder

## Type I

### Combine three orthogonally arranged uniaxial Hall sensors

- Poor spatial resolution (>250  $\mu\text{m}$ )
- Planar Hall effect to be compensated
- Angular errors (up to few deg.)

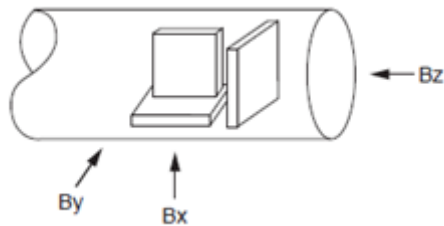

Association of three single axis planar devices

## Type II

### Integrated Hall Sensor in CMOS technology (three sensors in one chip)

- Performance of vertical Hall devices (-)
- Noise coming from electronic to amplify the output signals and compensate the parasitic effects
- Angular errors (up to 0.5  $^\circ$ )

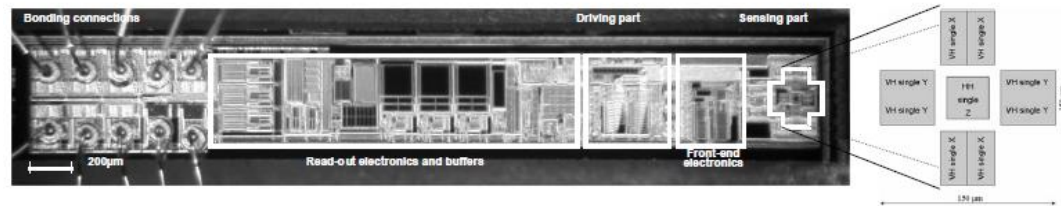

Association of vertical and planar Hall probe devices (example of SENIS)

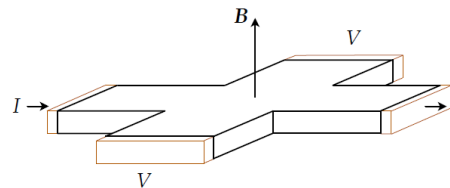

Planar devices

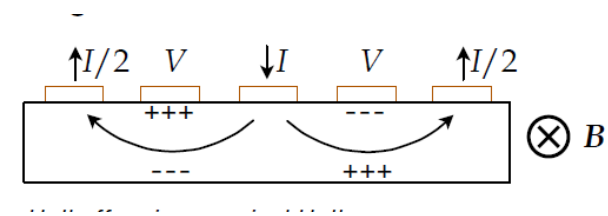

Vertical devices

Can we combine :high sensitivity, small volume, measure at the same spot, HPE cancelled?

**2<sup>nd</sup> Major upgrade : for next Swiss-FEL undulators and inhomogeneous magnets**



**ETH**  
Eidgenössische Technische Hochschule Zürich  
Swiss Federal Institute of Technology Zurich

UNI  
BASEL

PAUL SCHERRER INSTITUT  
PSI

EMPA

METROlab

CTI funded project

**ETH zürich**  
MAVT Chair of Micro- and Nanosystems

## New Type of Three-Axis Hall Sensor Designed for High-Accuracy Magnetic Field Measurements

Silke Christina Wouters  
PhD examination, 16.03.2016

**Motivation : novel Hall sensor for highly accurate (< 0.1 %) 3D magnetic field measurements**



# Compact and accurate three-axis sensor : The Hall cube

## Hallmarks

- Hall sensor **prototype** with 3D measurement precision ( $10^{-4}$  at 1 T in the three directions)
- Miniaturized sensors made of **six high-precision 1D planar Hall sensors without compensation electronics** : High sensitivity and precision of uniaxial Hall sensors is exploited
- Geometry : 6 probes (Double readings per field component) at the edge of a cube to measure **at single point** in space and time
- PHE compensation **thank to pairs of probes** per field direction positioned orthogonally

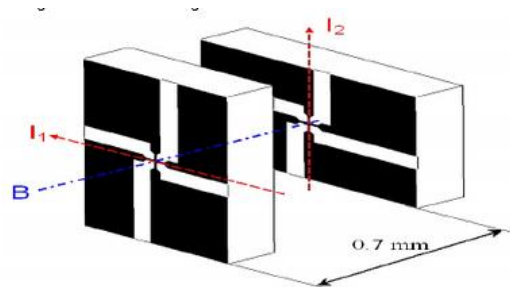

*I. Vasserman, B. Berkes, J. Xu, J. Kvitkovic (PAC2009)*

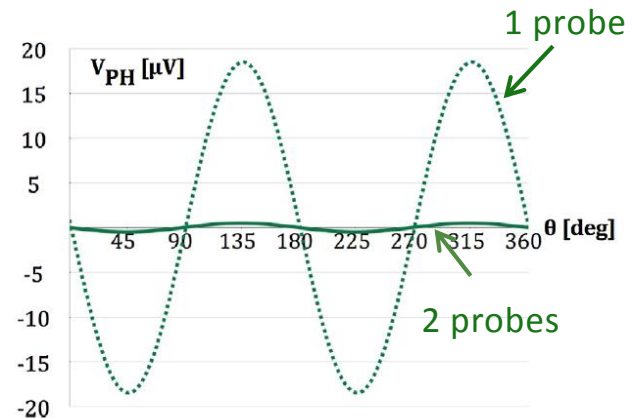

Compensation of the Hall planar component with a pair of parallel Hall plates rotated in plane  $\sim 90^\circ$  to each other

25 times reduced !

# Hall Cube design

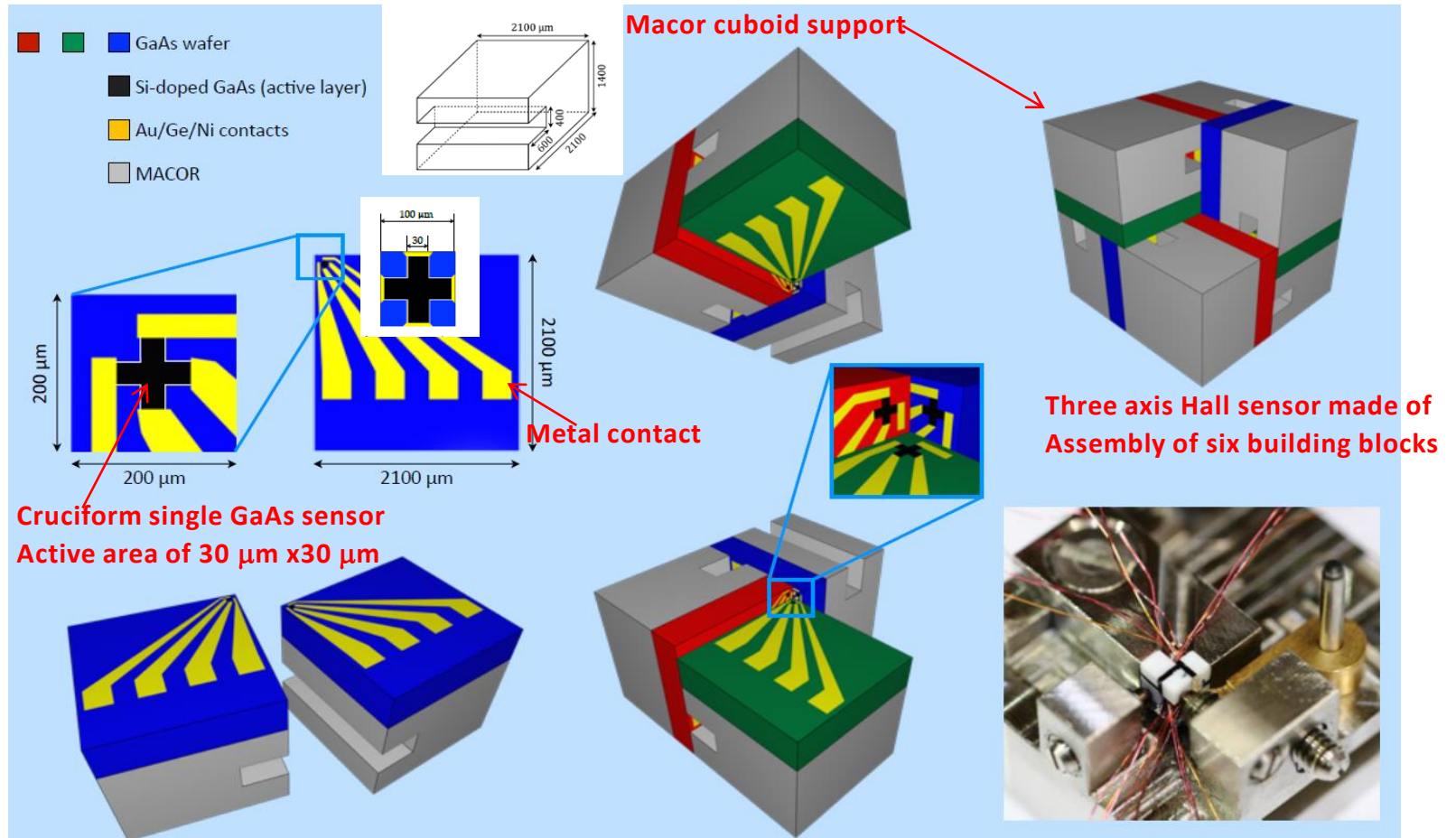

Geometry : sub-mm active volume ( $150 \times 150 \times 150 \mu\text{m}^3$ ) and outer sensor dimension in mm-range ( $< 4 \times 4 \times 4 \text{ mm}^3$ )

“Design and fabrication of an innovative three-axis Hall sensor”, C. Wouters et al., *Sensors and Actuators A* 237 (2016) 62–71

Prototype calibrated and tested in a magnet and an undulator in Fall 2015

# Vibrating wire for magnetic axis measurement

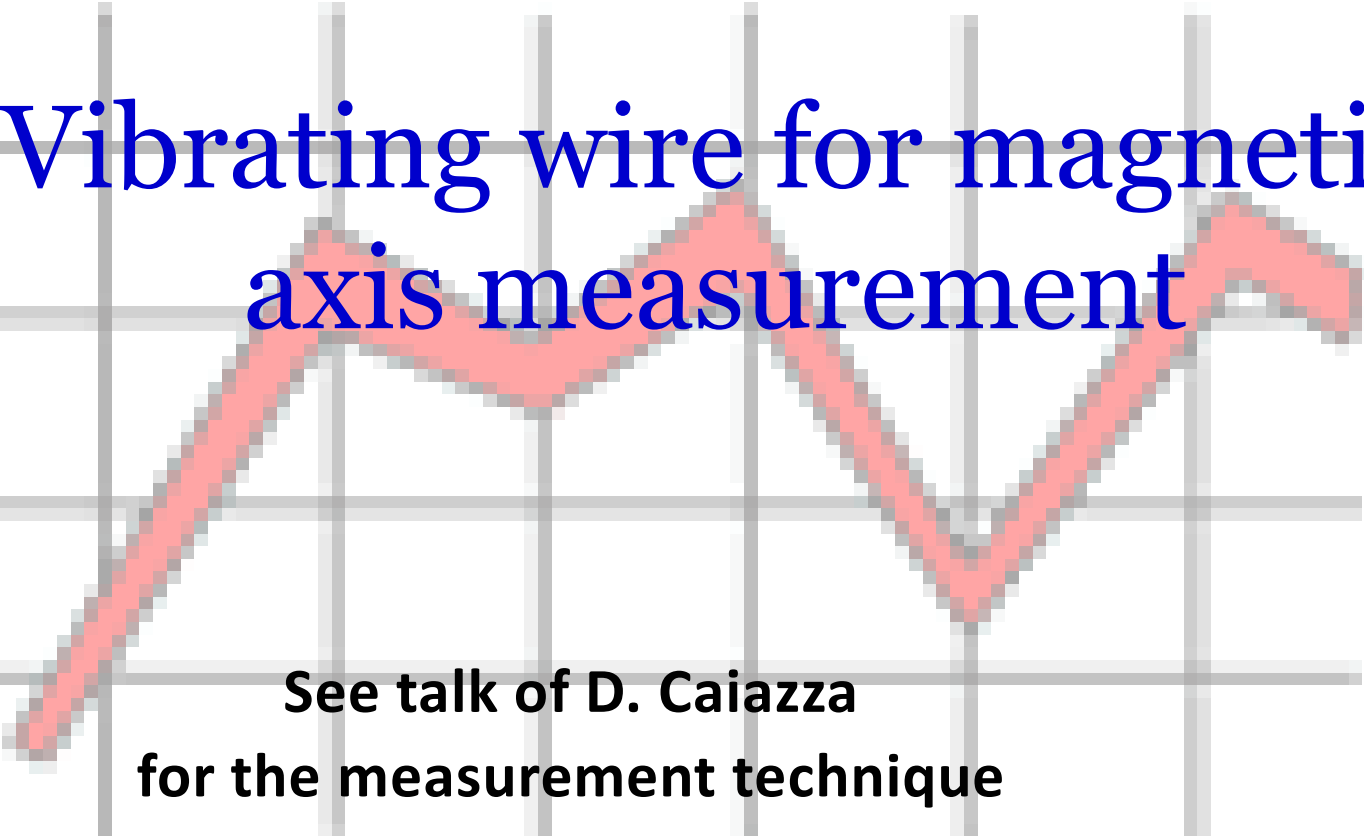

See talk of D. Caiazza  
for the measurement technique  
& technical challenges

**Goal : Measure the magnetic axis position of the Quadrupoles  
Tolerance (fiducialisation included) < 50  $\mu\text{m}$  rms**

# PSI vibrating wire system

## Key points

- Developed at PSI in 2011; Improvements up to 2014.
- Small/medium size magnets (few hundreds of kg,  $\sim 0.5$  m)
- **Tensioned wire** (CuBe,  $\varnothing \sim 100 \mu\text{m}$ ) between two stages
- **Magnet is fixed; Wire is moved;**  $L_{\text{wire}} \sim 1.2$  m
- **Vibration detection** : inductive method with 2 pairs of coils working in the 1<sup>st</sup> and 2<sup>nd</sup> harmonic;
- Lock-in amplifier to detect the voltage drops and measure the change of phase + PLL to compensate the change of resonance frequency during the movement.
- **Fiducialisation** : 12 points measured with a FARO arm (4 fiducials+ 8 points related to the wire holders)

## Uncertainty

- Coming from the fiducialisation method (reference points, home position)
 
$$\sigma \sim 25 \mu\text{m}$$
- Relative accuracy (mag. Method)  $\sigma \sim 1 \mu\text{m}$

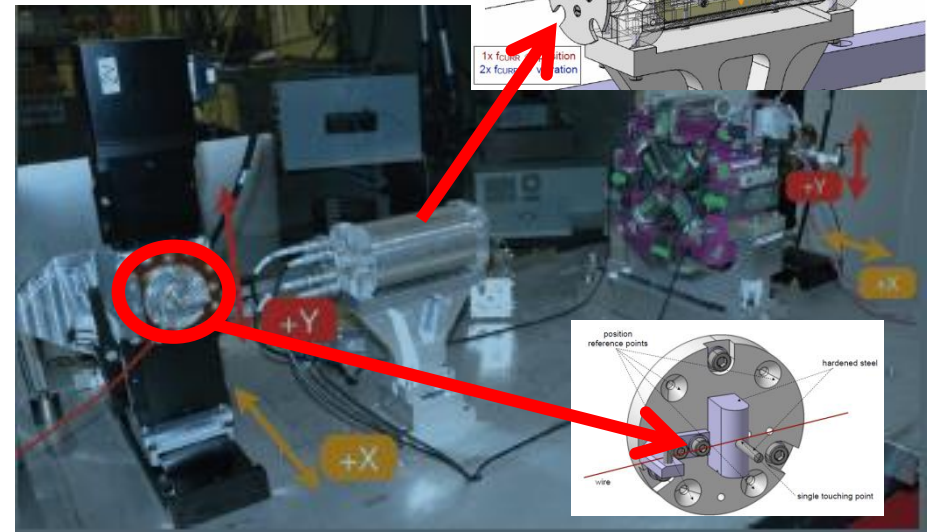
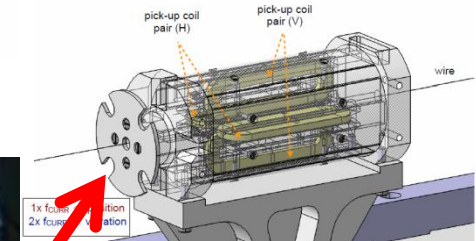
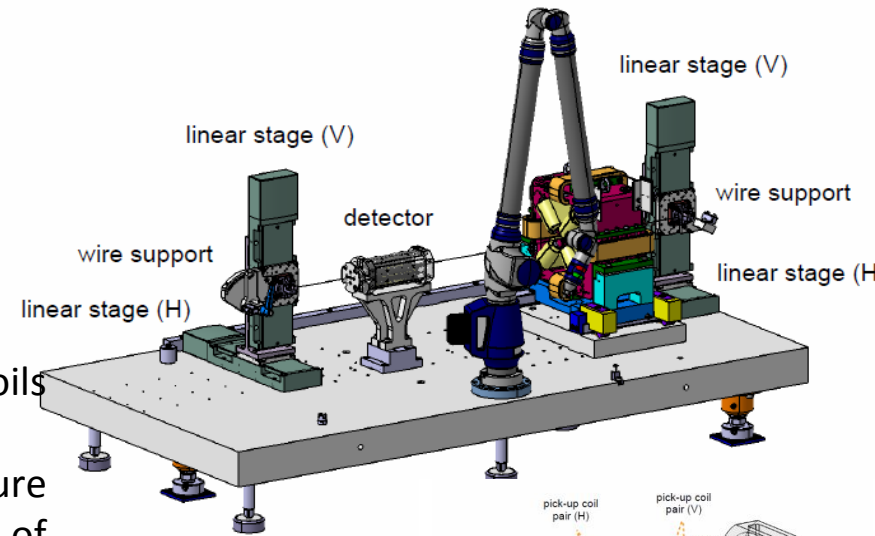



Specific magnetic measurement results

# Multi-probes: Field scan SwissFEL quadrupole

## Hall probe : Field profiles (magnet homogeneity)

QFF	p1	p2	p5	p6
$G_0$ Gauss/mm	543.4	542.5	540.4	540.3

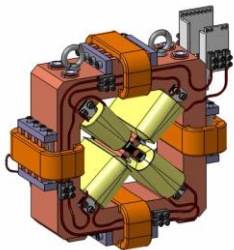
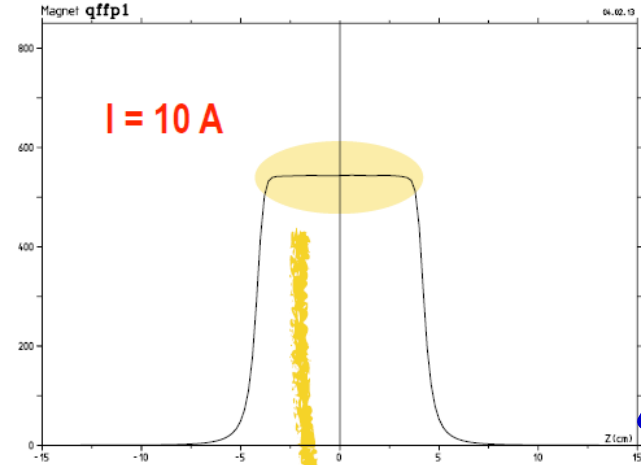

G (Gauss /mm)

QFFP2: OK for the field integral value  
but 0.7 % variation of the field  
gradient value along the axis

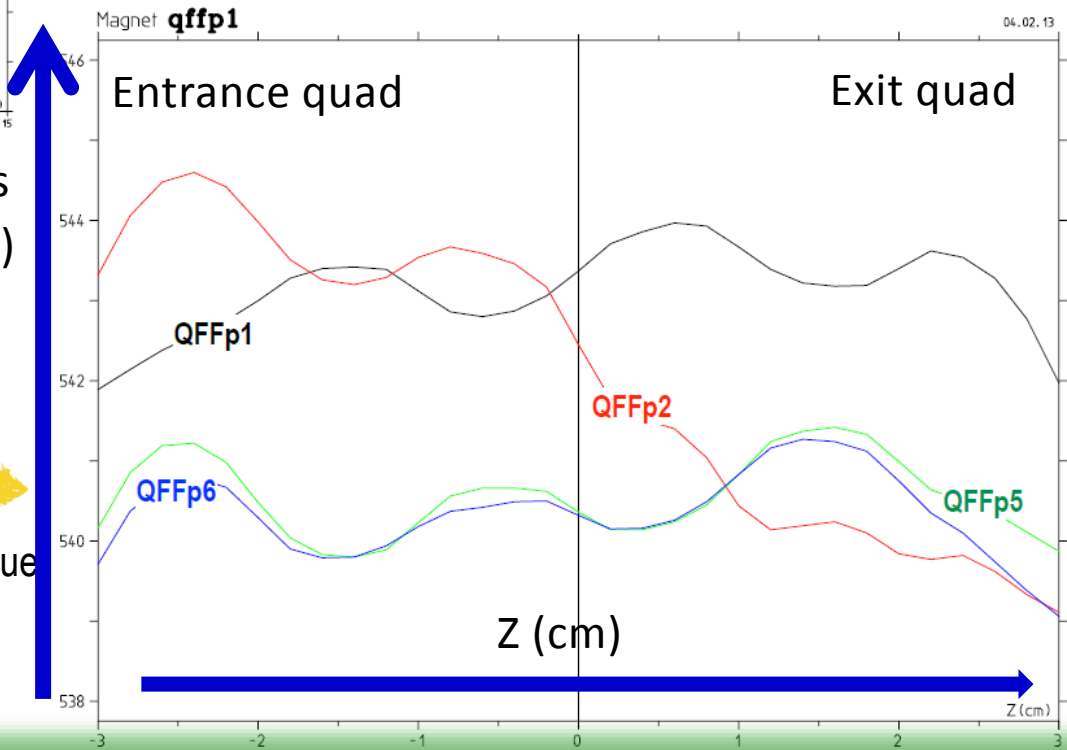

**Hall probe measurements are essential to complement Rot. Coils  
measurements which measured only field integrals**

# U15 undulator: trajectory optimization (Senis probe)

Hall probe measurements

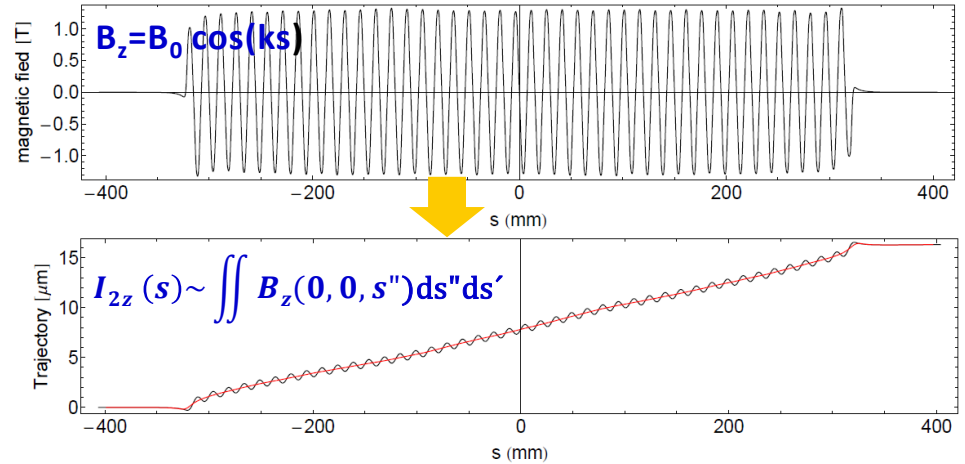
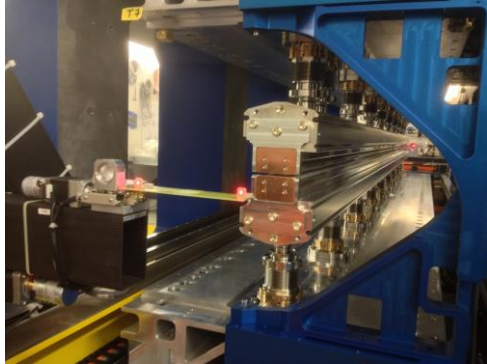

Local correction  
of the PM position

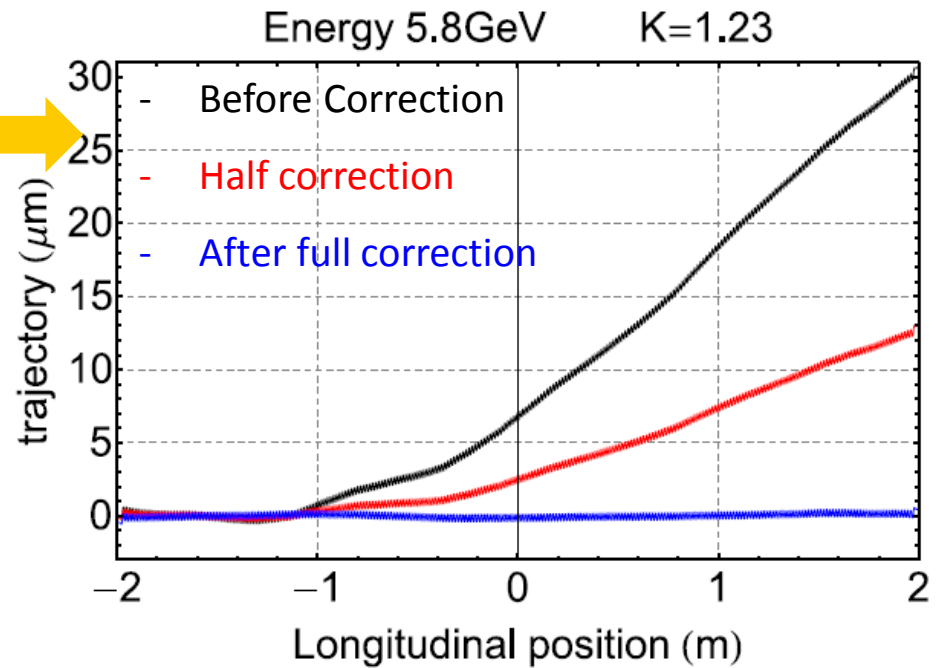
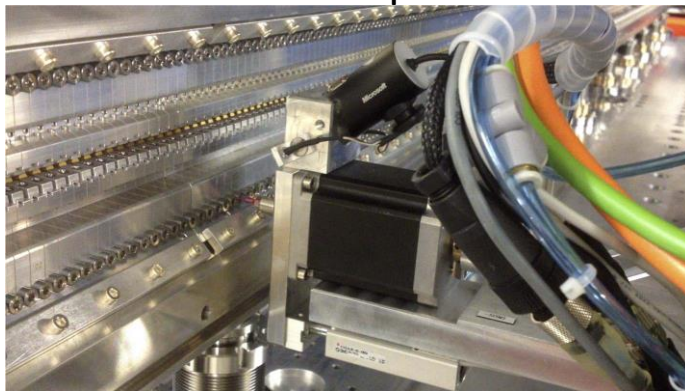

Few  $\mu\text{m}$

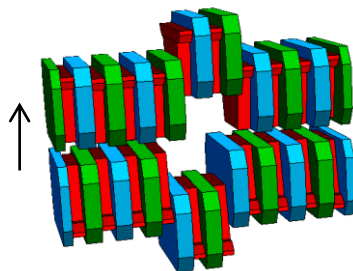

# Hall-Cube : Undulator U50 measurement

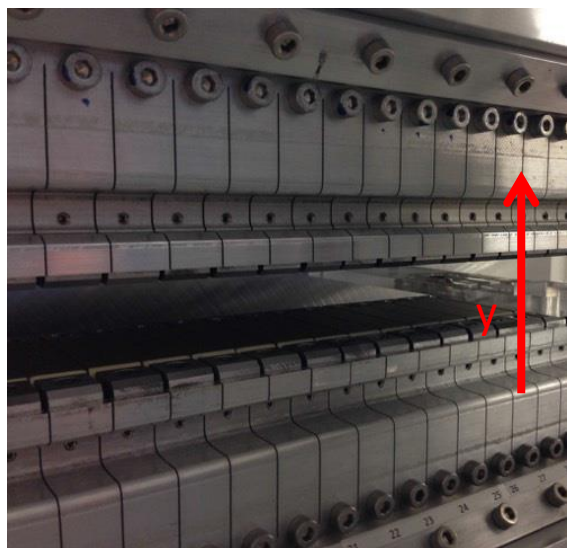
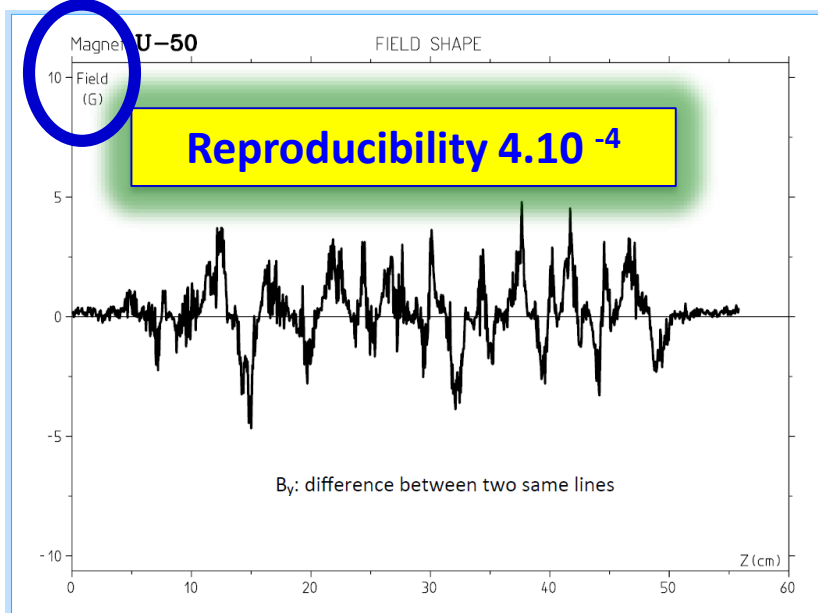
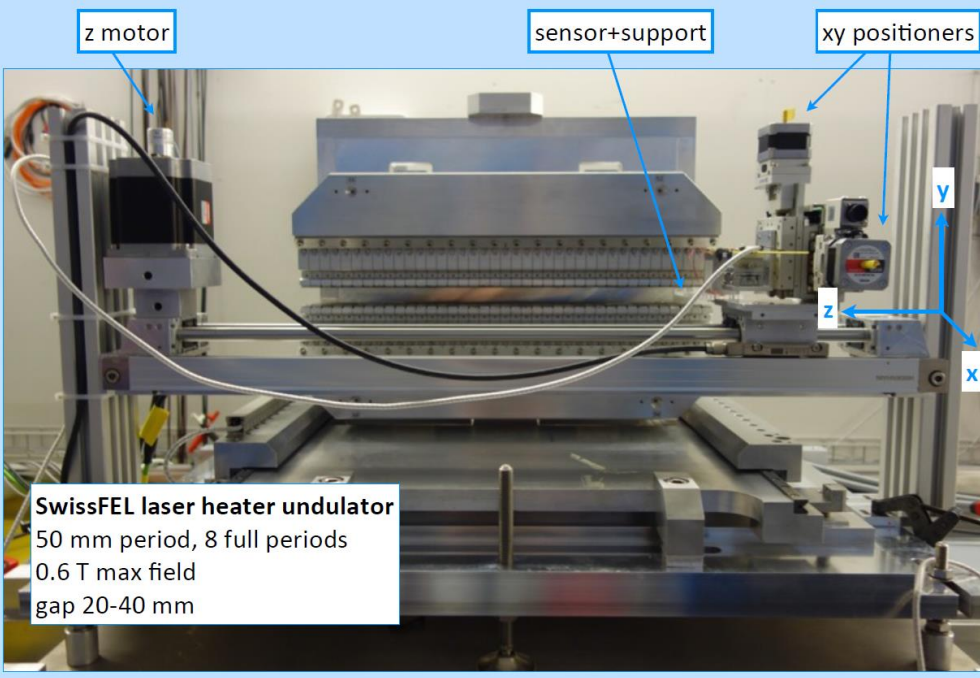

$$B_y = B_{\max} \sin\left(\frac{2\pi z}{\lambda}\right)$$

0.6 T      50 mm

at any position  $s$  along  $z$ :

Main component  $B_y$   
 Side components,  $B_x, B_z$

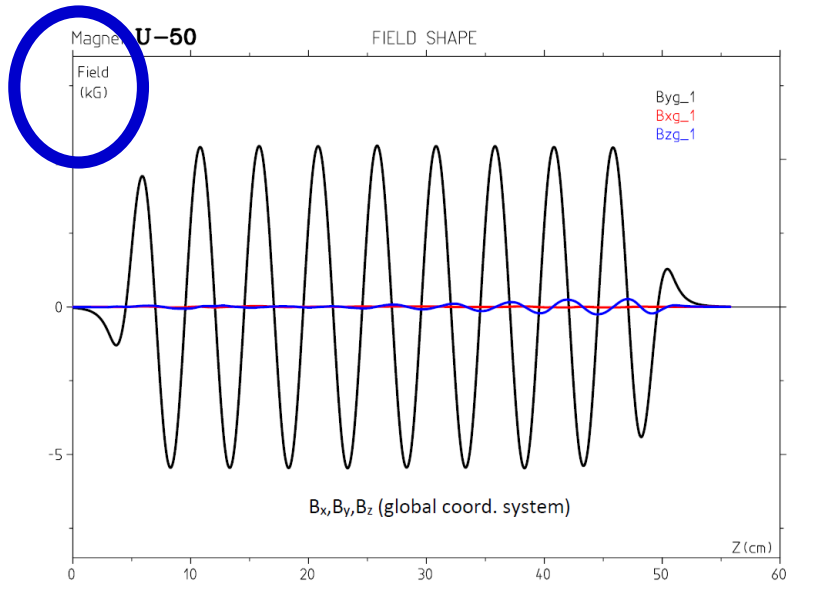

Magnetic field components along the undulator



# Vibrating wire : magnetic axis vs. time (air-cooled quadrupole at $I=6$ A)

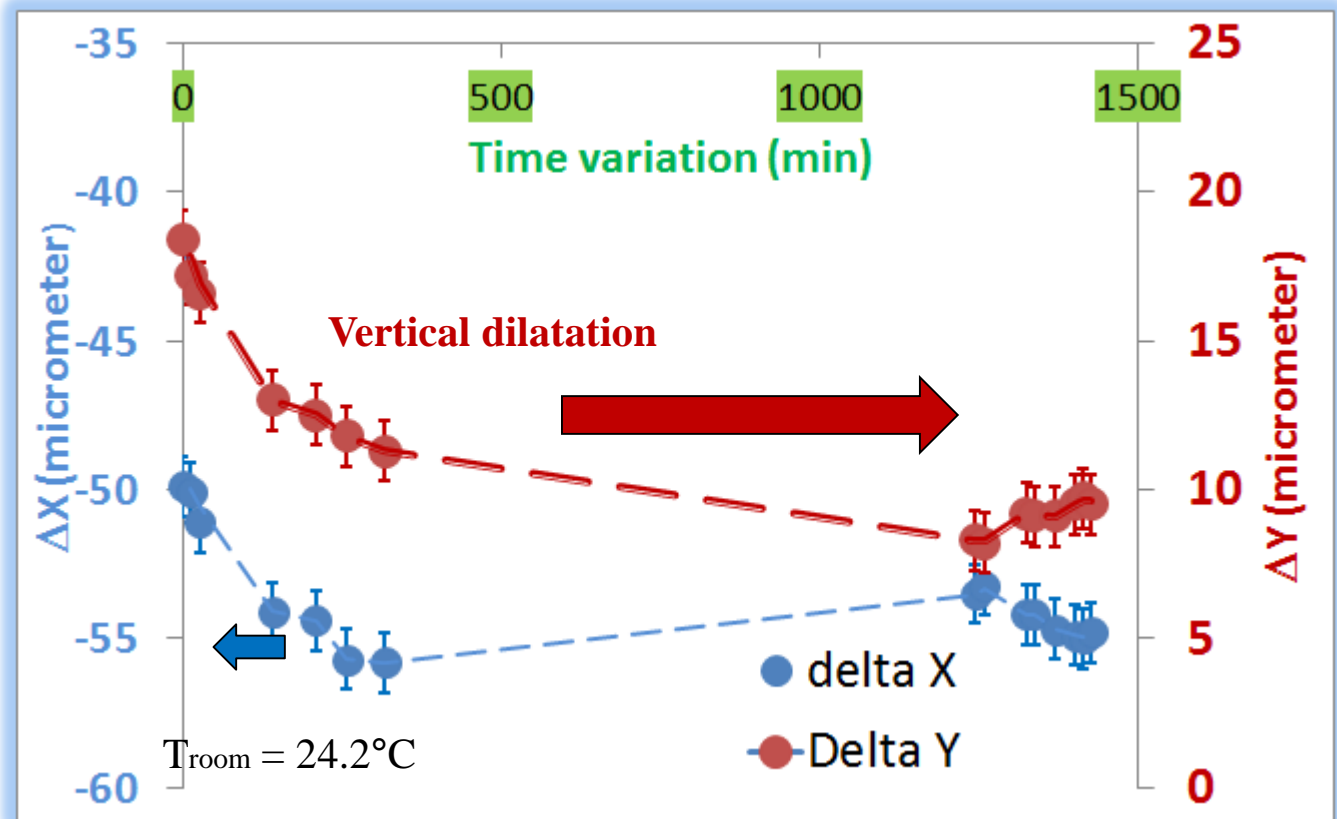

Steady state after 6 hours ( $T_{\text{end}} = 28.5^\circ\text{C}$ )

Vertical dilatation (at 6 A):  $9\ \mu\text{m}$

# Summary and future directions

- For the Swiss-FEL, various complementary magnetic measurement systems were developed and used to measure 273 magnets and 12 undulators. Measurements will be completed for September 2016
- Future measurement system developments are linked with the next PSI projects and collaborations

## Superconducting dipole /quadrupoles for a Gantry (2015-2018) -Racetrack geometry

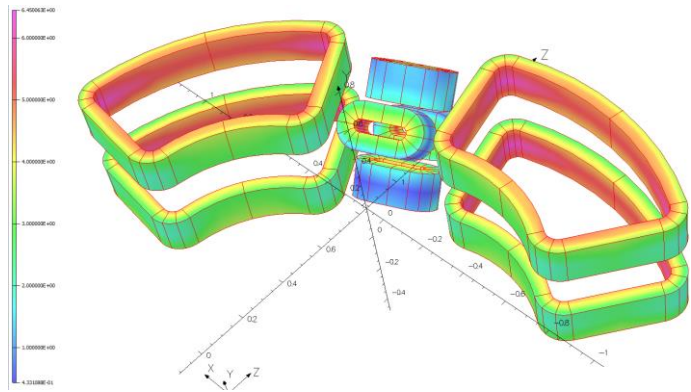

Bending angle:  $60^\circ$ ;  
Bending  $R=0.8$  m

*C.Calzolaio*

## Super-bend for the SLS upgrade 6 T peak in the middle (2016-2018)

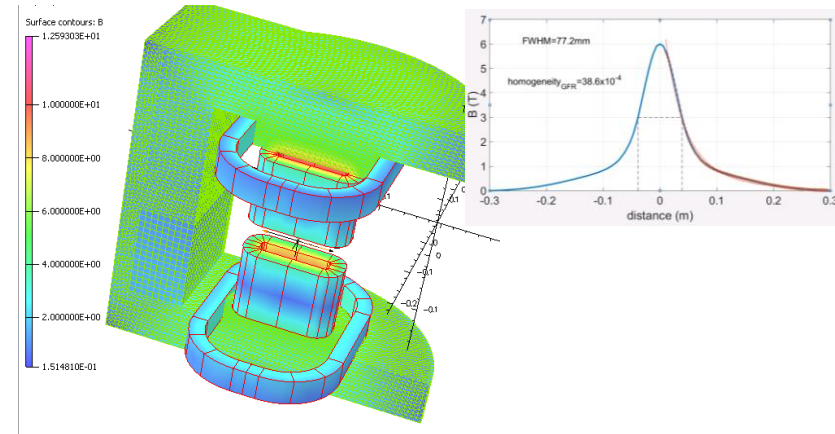

## Undulators with a circular mode (Athos line-2018)

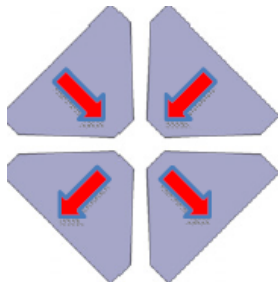
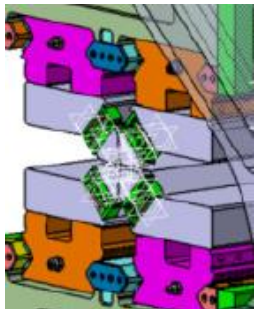

*Th.Schmidt*

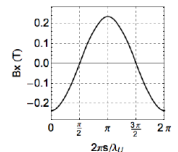
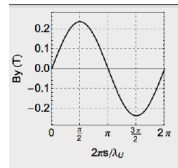

## Challenges are measurement systems for

- Large aperture and strongly curved dipoles
- Small aperture and inhomogeneous field
- Undulators with circular polarization
- Small gap –in vacuum (supercon.) undulators

# Some useful references

## SwissFEL- Magnets/undulators

- Design and magnetic performance of small aperture prototype quadrupoles for the SwissFEL at the Paul Scherrer Institut ; S. Sanfilippo et al.; IEEE Transaction on Applied Superconductivity VOL. 24, 3, (2014)
- “In-situ undulator field measurement with the SAFALI system,” T. Tanaka et al., in Proc. FEL Conf., Novosibirsk, Russia, 2007, pp. 468–471
- “SwissFEL U15 Magnet Assembly : First experimental Results”; M. Calvi et al., Proceedings of FEL2012, Nara, Japan;

## Hall probes

- Hall effect Devices-2<sup>nd</sup> Edition; R.S. Popovic; IOP (2004)
- “Design and fabrication of an innovative three-axis Hall sensor”, C. Wouters et al., Sensors and Actuators A 237 (2016) 62–71

## Vibrating Wire

- “Vibrating wire field-measuring technique,” A. Temnykh, Nucl. Instr. And Meth. A, vol. 399, pp. 185–194, 1997.
- “Vibrating Wire Technique and Phase Lock Loop for Finding the Magnetic Axis of Quadrupoles”, C. Wouters et al., IEEE Transaction on Applied Superconductivity VOL. 22, 3, (2012)

A red line graph is plotted on a grey grid. The line starts at a low point on the left, rises to a peak, dips slightly, rises to a higher peak, dips to a low point, and then rises again to a peak on the right. The text 'Thank you for your attention' is overlaid on the graph.

Thank you for your  
attention

Questions?

# Annexe

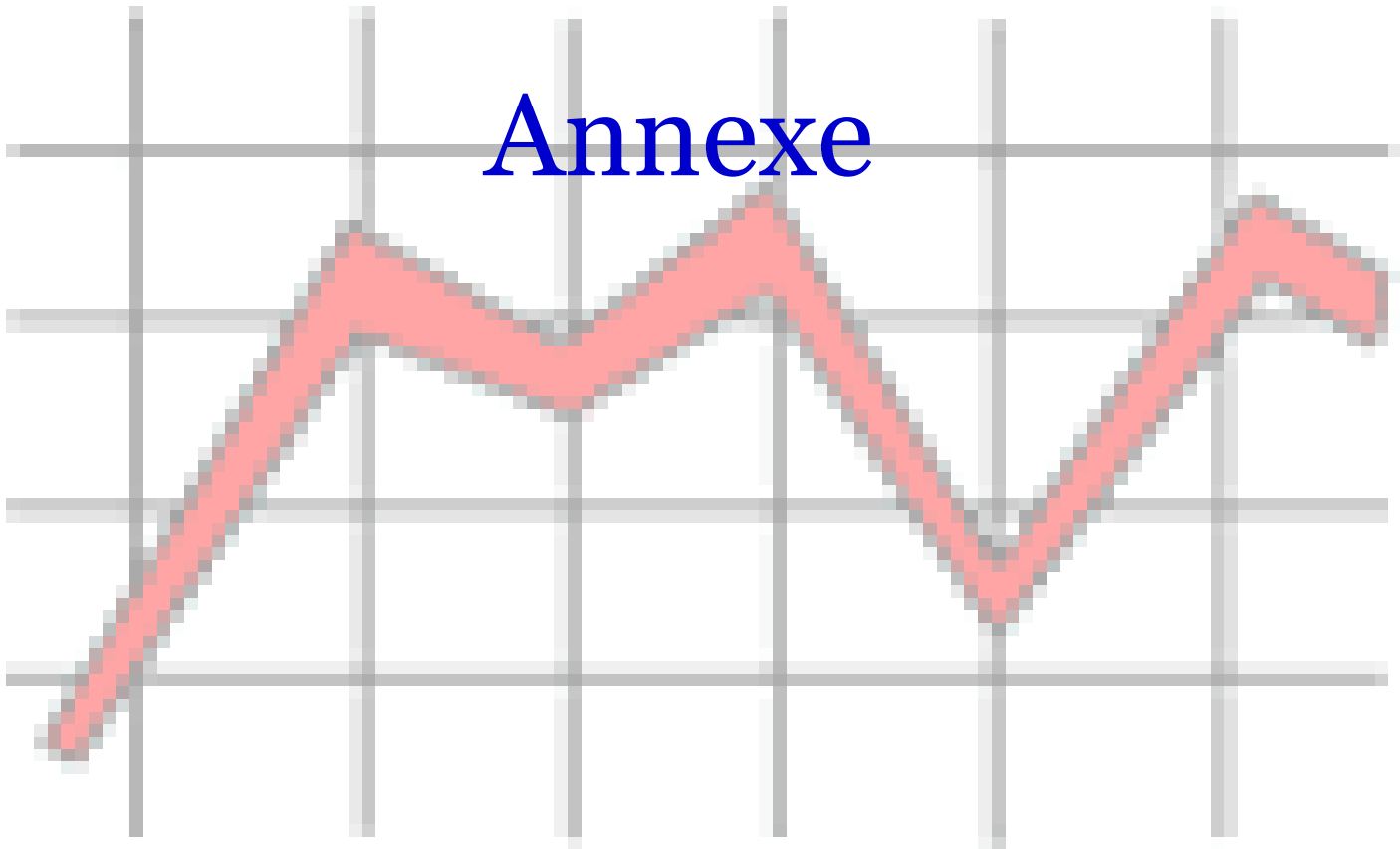

# Hall Cube calibration

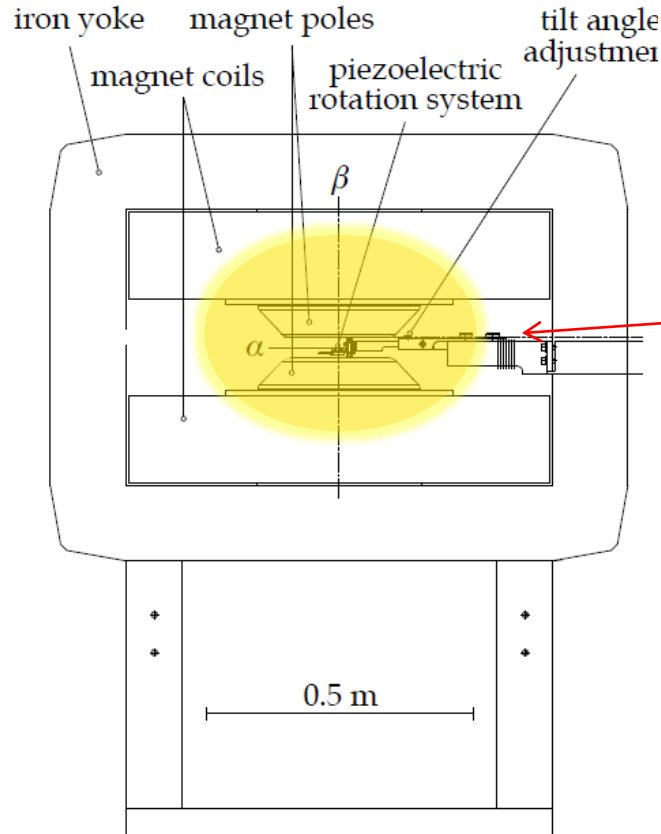

## Calibration Magnet

-96 A ↔ 96A or -2 T ↔ 2T  
 gap = 38 mm  
 homogeneity at 2 T: 100 ppm  
 in area of 10 mm radius

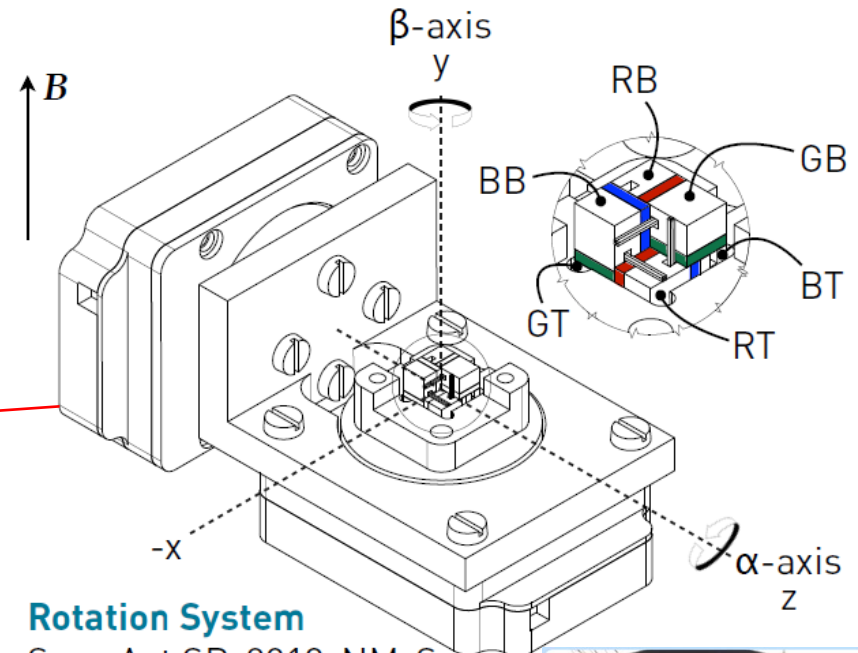

## Rotation System

SmarAct SR-2013-NM-S  
 movement resolution: <math><3 \mu\text{rad}</math>  
 sensor resolution: 25  $\mu\text{rad}</math>  
 rot.  $\varnothing$ : 33.12 mm$

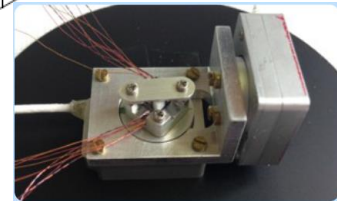

**Calibration of each individual sensor**  
**Sensor assembly (angular errors ~ 0.1 mrad)**

**Calibration of the Hall-cube per pairs:**

- Orthogonality error among sensors
- Planar Hall effect compensation

# Vibrating wire development

(A. Temnykh, Nucl. Instr. and Meth.. A399 (1999) 185)

## Principle

Stretched conducting wire driven with an AC current  $I = I_0 \cos \omega t$  at one of its natural frequencies  $\omega_n$  in the presence of a magnetic field:

- Off axis: strong vibration (resonance) → Voltage can be detected by a lock-in amplifier
- Wire along the magnetic axis: no vibration because no magnetic field
- Vibration detector and fiducialisation system → position of the magnetic axis w.r.t fiducials

### At resonance (off magnetic axis)

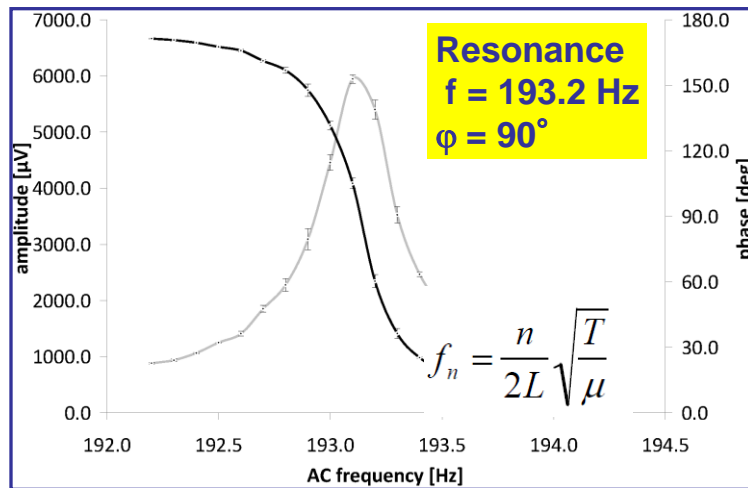

voltage detected (vibration) and  $\phi = \pi/2$

### Difficulties:

- Sensibility of the vibration detectors
- Fiducialisation

### Crossing the magnetic axis

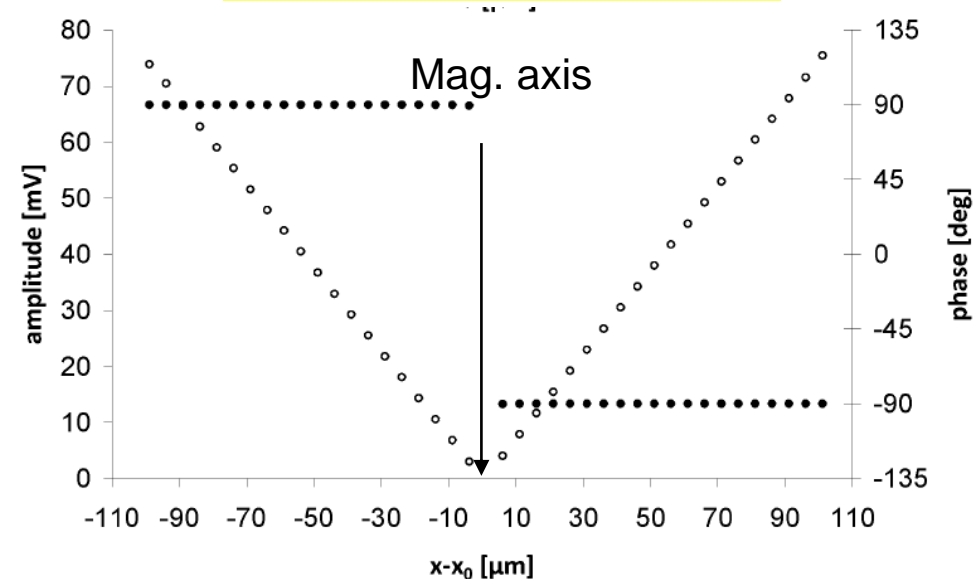

- “V” shape for the amplitude
- Jump from  $\pi/2$  to  $-\pi/2$  for the phase

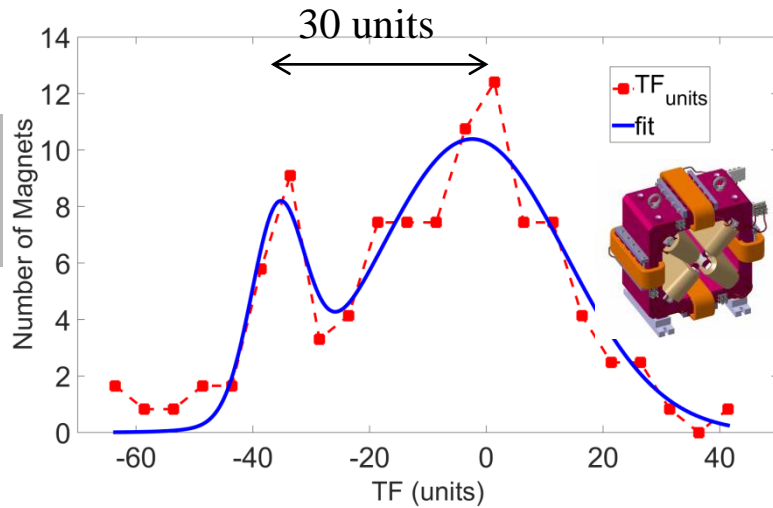

Statistics on 120 quads

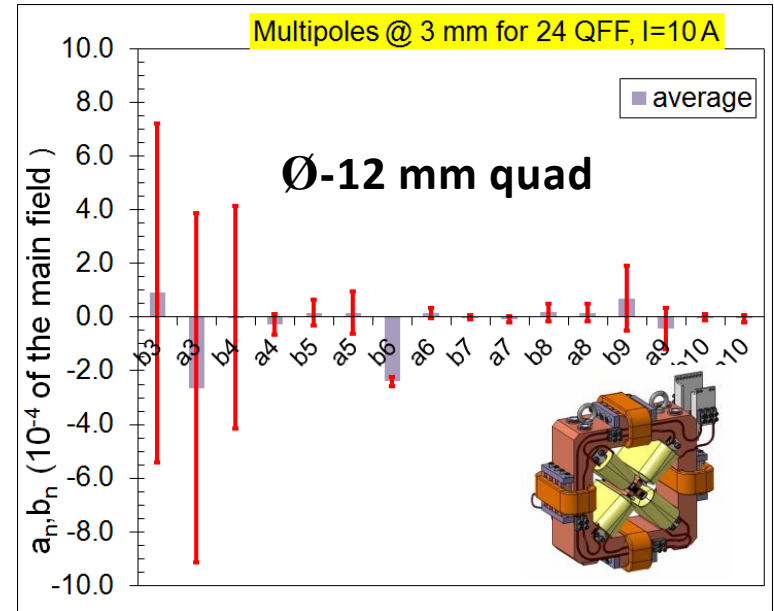
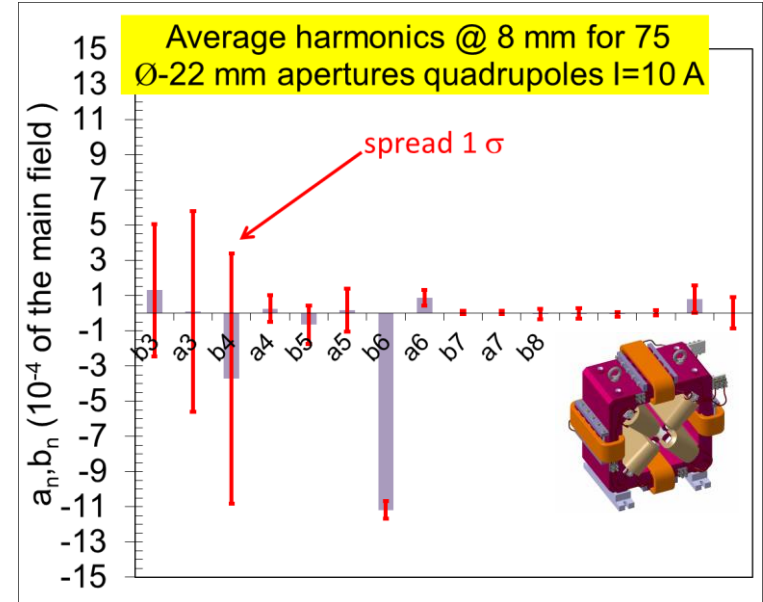
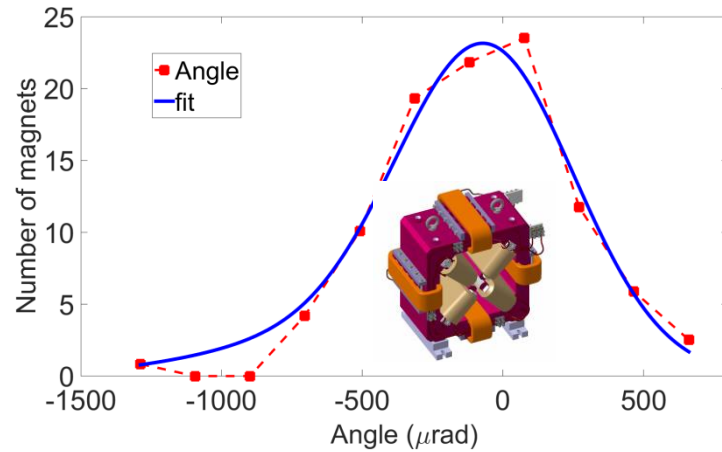



# U15 flexor block keeper design

- Block keeper extruded Al
- Common clamp with a 50 $\mu$ m nose for plastic deformation to match tolerances
- Preload 60 $\mu$ m  
Adjustment  $\pm$  30 $\mu$ m

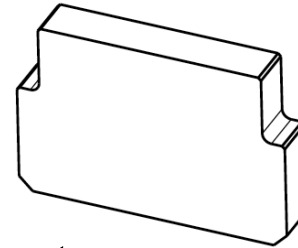

magnet  
Dy diffused NdFeB

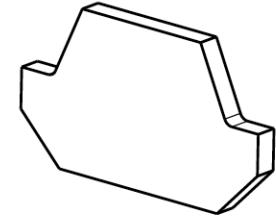

pole  
with 15mm pole tip

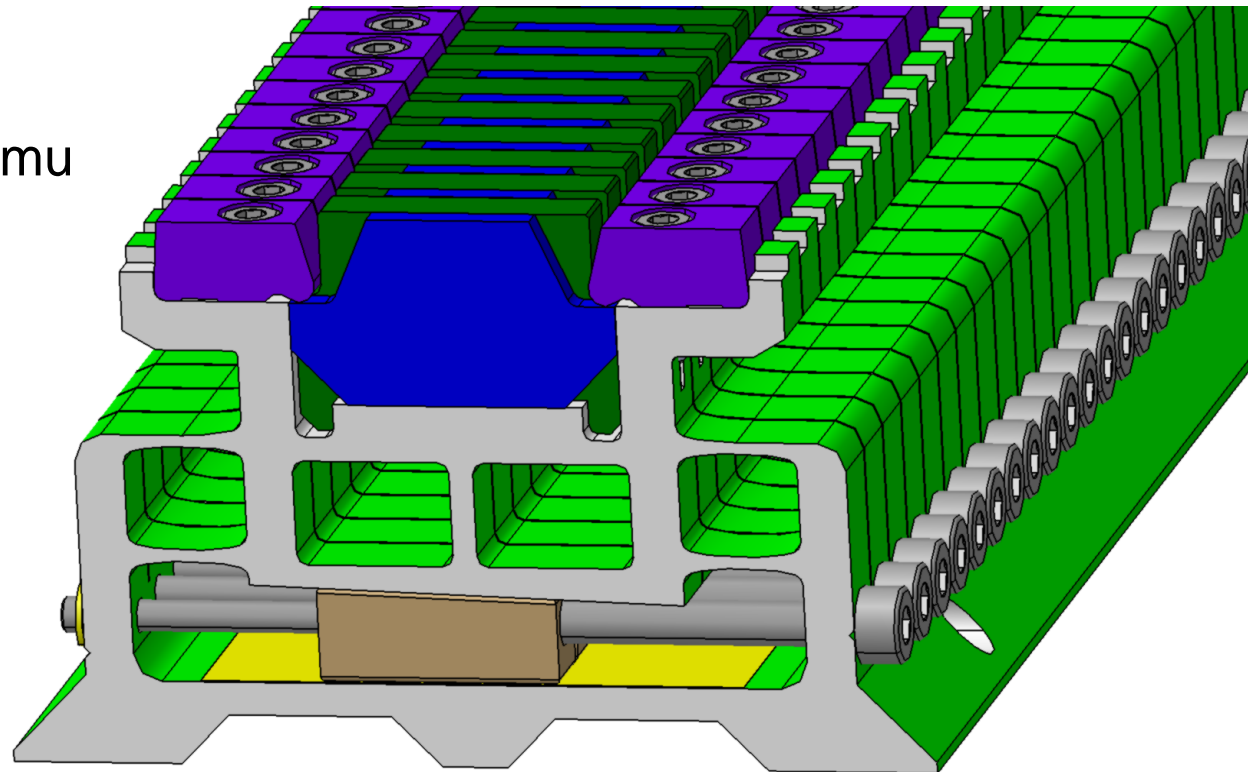

lasers blocked by  
pinholes

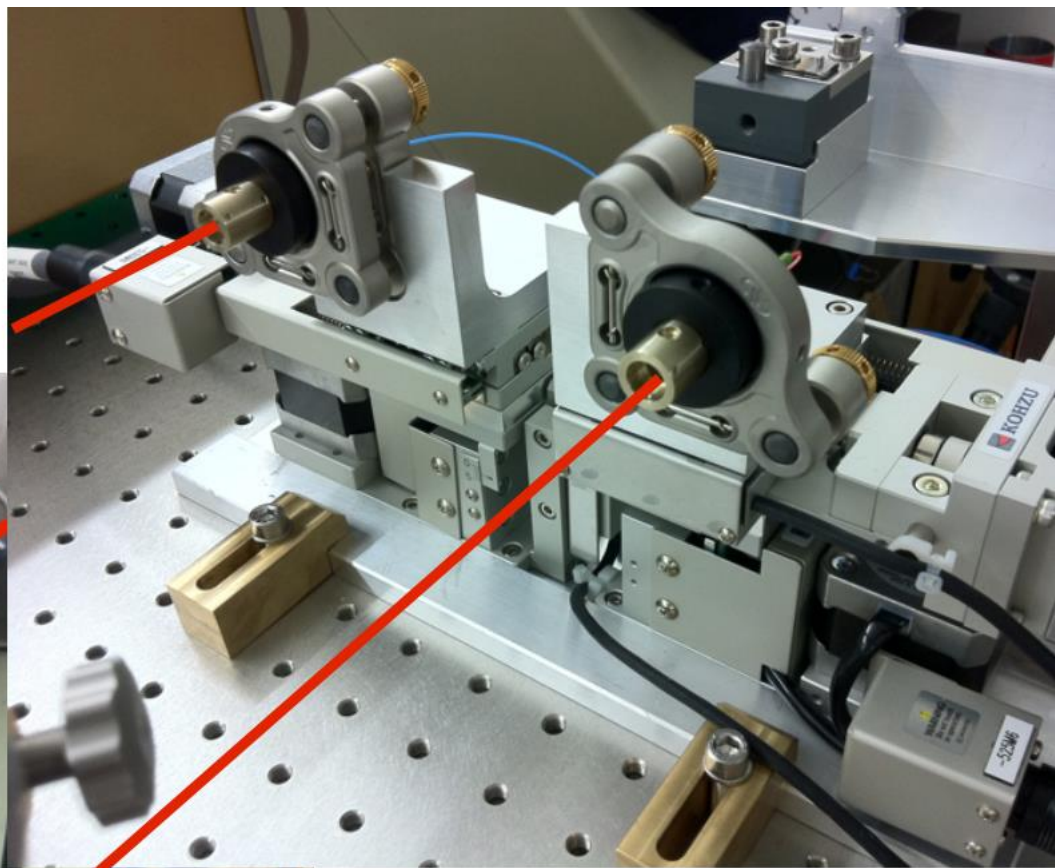
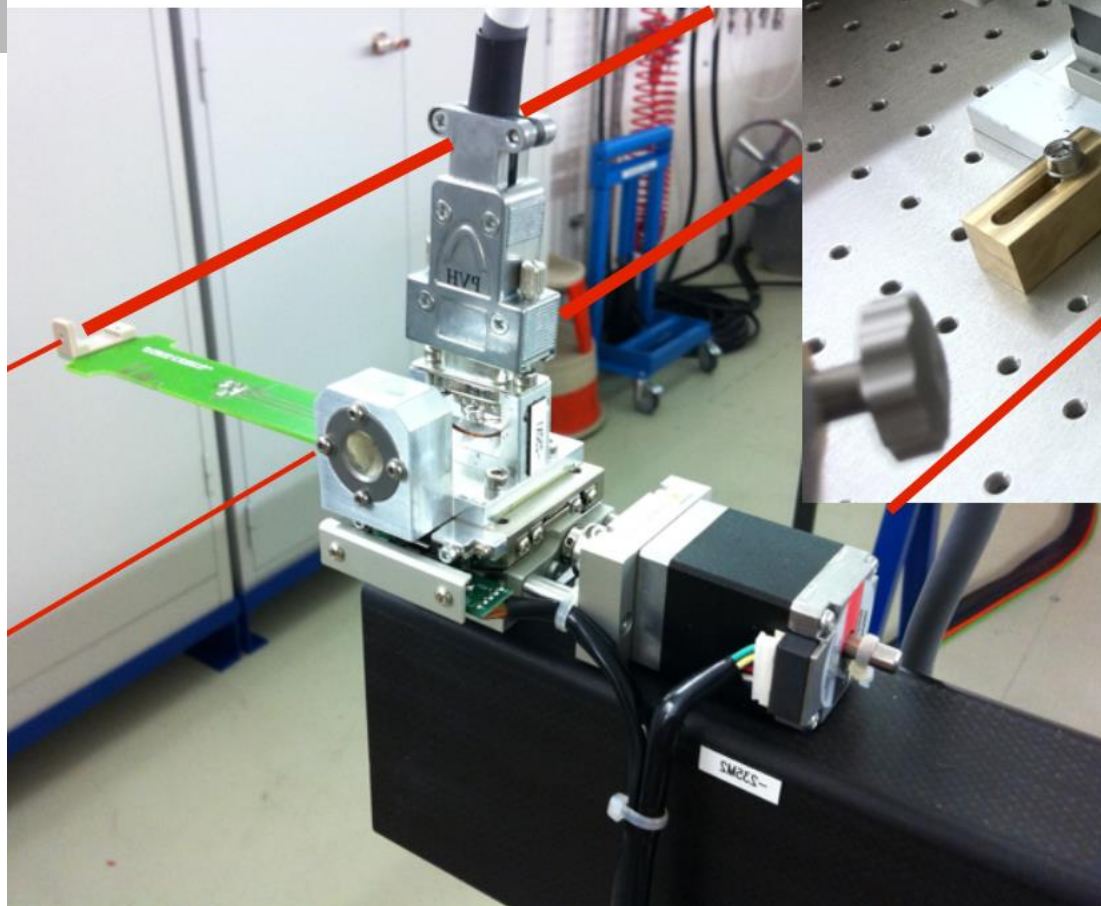

split diode laser  
pointing stabilized by  
optical fibers

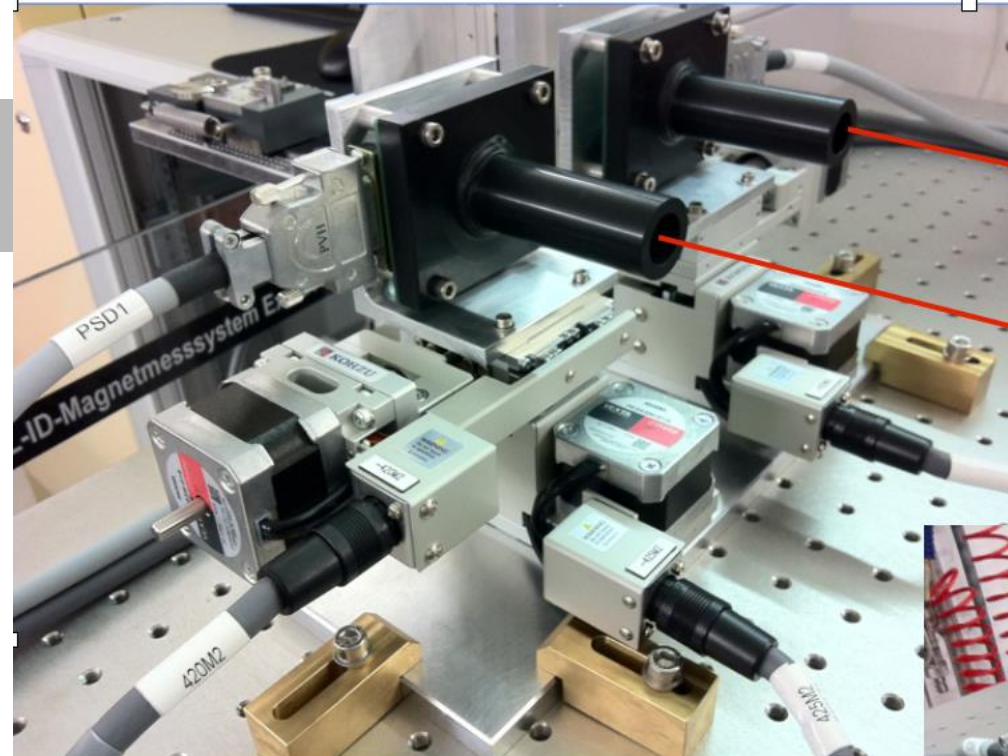

PSD  
position sensitive diode  
for position control

closed loop for Hall probe

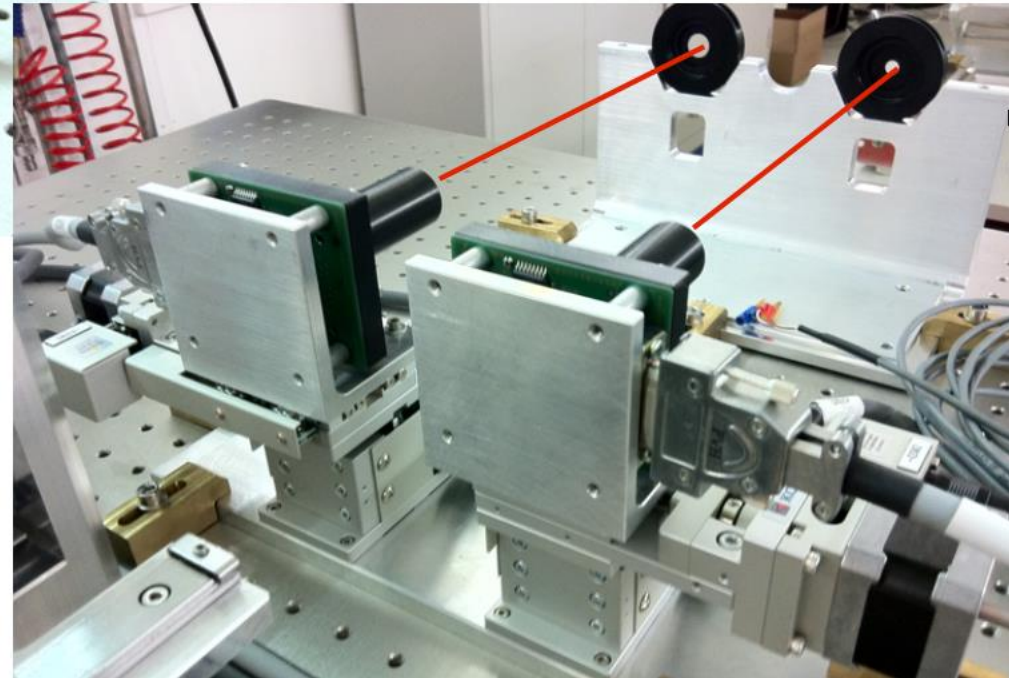

# Vibrating wire : magnetic axis vs. temperature (air-cooled quadrupole)

Xpos ( $\mu\text{m}$ )

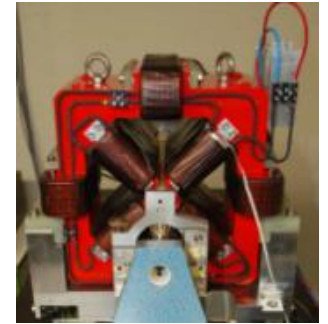
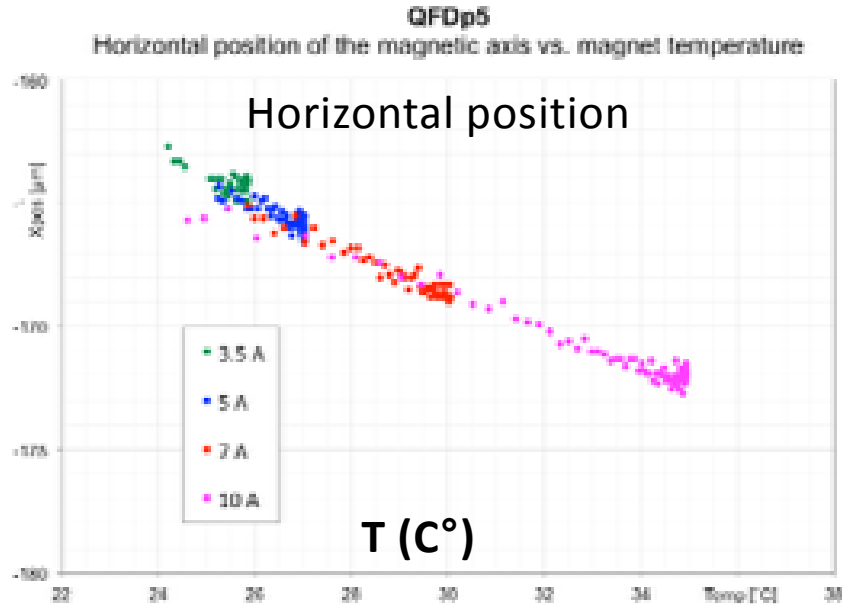

Ypos ( $\mu\text{m}$ )

