

# HT Lecture on Nonlinear beam dynamics (I)

Motivations: nonlinear magnetic multipoles

Phenomenology of nonlinear motion

Simplified treatment of resonances (stopband concept)

Hamiltonian of the nonlinear betatron motion

# HT Lecture on Nonlinear beam dynamics (II)

Hamiltonian of the nonlinear betatron motion

Resonance driving terms

Tracking

Dynamic Aperture and Frequency Map Analysis

Spectral Lines and resonances

Nonlinear beam dynamics experiments at Diamond

# Linear betatron equations of motion

In the magnetic fields of **dipoles magnets** and **quadrupole magnets** (without imperfections) the coordinates of the charged particle w.r.t. the reference orbit are given by the Hill's equations

$$\frac{d^2 y}{ds^2} + K_y(s)y = 0 \quad K_x(s) = \frac{1}{\rho^2(s)} - \frac{1}{B\rho} \frac{\partial B_z(s)}{\partial x}$$
$$K_z(s) = \frac{1}{B\rho} \frac{\partial B_z(s)}{\partial x}$$

These are linear equations (in  $y = x, z$ ). They can be integrated and give

$$y(s) = \sqrt{\varepsilon_y \beta_y(s)} \cos[\phi_x(s) + \phi_{x0}] \quad \phi_y(s) = \int_{s_0}^s \frac{ds'}{\beta_y(s')}$$

Nonlinear terms in the Hill's equation appear due to nonlinearities in the magnetic elements of the lattice present as unavoidable errors (gradient errors) or deliberately included in the lattice

# Multipolar expansion of magnetic field

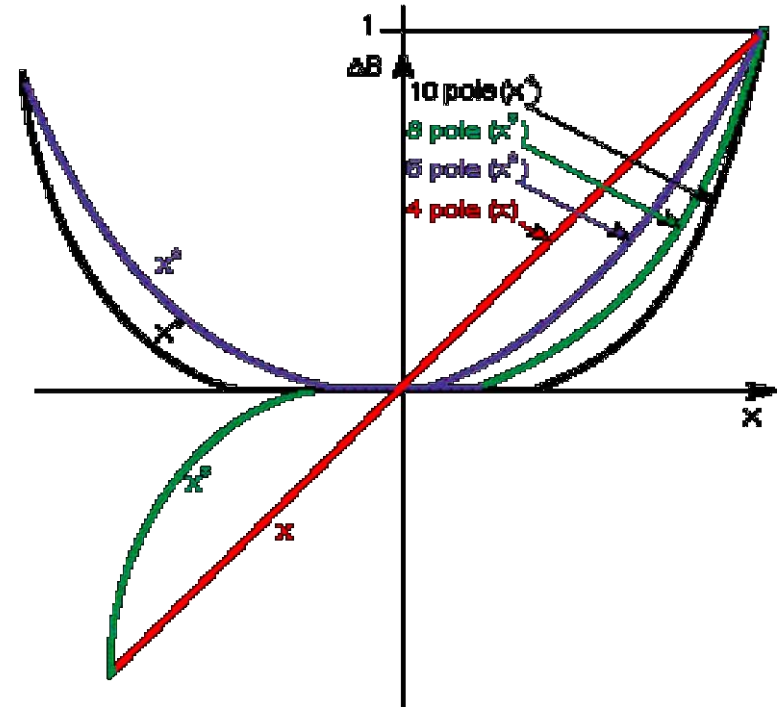
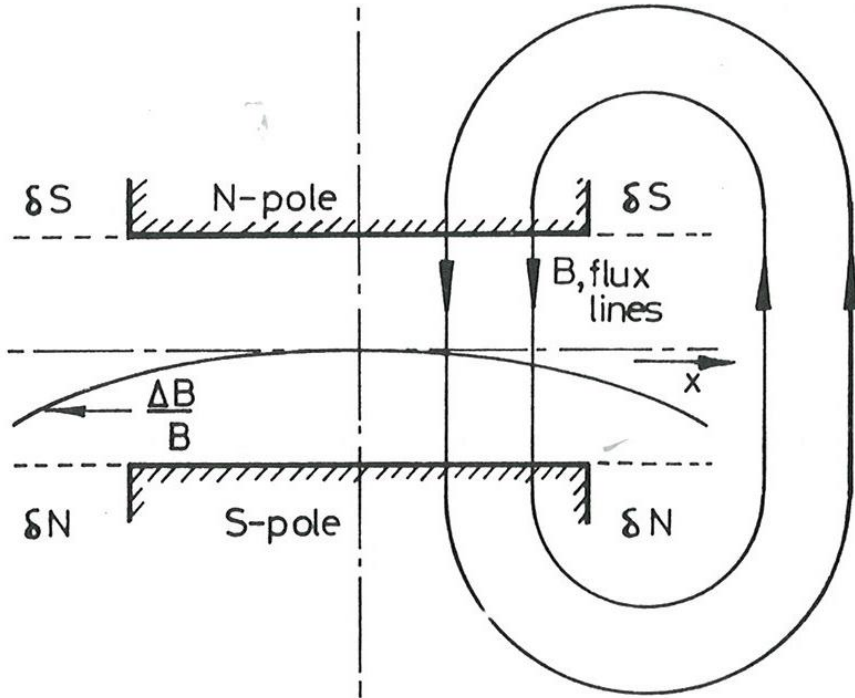

The on axis magnetic field can be expanded into multipolar components (dipole, quadrupole, sextupole, octupoles and higher orders)

$$B_z = B_0 + \frac{1}{1!} \frac{\partial B_z}{\partial x} x + \frac{1}{2!} \frac{\partial^2 B_z}{\partial x^2} x^2 + \frac{1}{3!} \frac{\partial^3 B_z}{\partial x^3} x^3 + \dots$$

# Hill's equation with nonlinear terms

Including higher order terms in the expansion of the magnetic field

$$B_z + iB_x = B_0 \rho_0 \left[ \sum_{n=1}^M \frac{k_n(s) + ij_n(s)}{n!} (x + iz)^n \right]$$

$$k_n = \frac{1}{B_0 \rho_0} \left. \frac{\partial^n B_y}{\partial x^n} \right|_{(0,0)} \quad \text{normal multipoles}$$

$$j_n = \frac{1}{B_0 \rho_0} \left. \frac{\partial^n B_x}{\partial x^n} \right|_{(0,0)} \quad \text{skew multipoles}$$

the Hill's equations acquire additional nonlinear terms

$$\frac{d^2 x}{ds^2} + \left( \frac{1}{\rho^2(s)} - k_1(s) \right) x = \operatorname{Re} \left[ \sum_{n=2}^M \frac{k_n(s) + ij_n(s)}{n!} (x + iz)^n \right]$$

$$\frac{d^2 z}{ds^2} + k_1(s) z = -\operatorname{Im} \left[ \sum_{n=2}^M \frac{k_n(s) + ij_n(s)}{n!} (x + iz)^n \right]$$

**No analytical solution available in general:**

**the equations have to be solved by tracking or analysed perturbatively**

# Example: nonlinear errors in the LHC main dipoles

Finite size coils reproduce only partially the  $\cos-\theta$  desing necessary to achieve a pure dipole fields

$$\text{Dipole } I(\phi) = I_0 \cos \phi$$

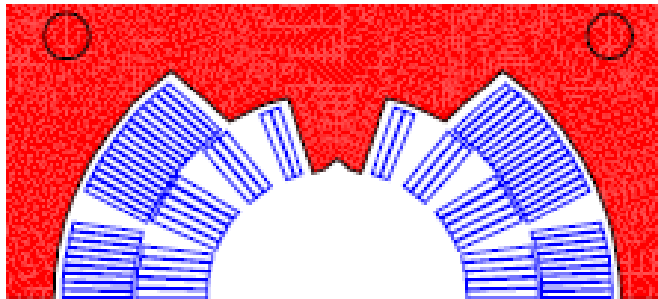
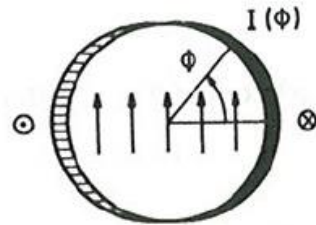

LHC main dipole cross section

TABLE I

MEASURED MULTIPOLES IN THE MBP2N1 PROTOTYPE:  
AVERAGE OF 18 MEASUREMENTS ALONG THE MAGNET AXIS.  
UNITS OF  $10^{-4}$  AT  $R_{ref} = 17$  mm.

	Collared		Assembled		After cryo	
	Ap. 1	Ap. 2	Ap. 1	Ap. 2	Ap. 1	Ap. 2
<i>a</i> 2	0.94	0.43	0.98	0.75	0.89	0.81
<i>b</i> 2	-0.96	1.25	-5.48	5.73	-4.99	5.13
<i>a</i> 3	-0.11	0.29	-0.38	-0.01	-0.46	0.00
<i>b</i> 3	2.08	2.71	8.09	8.68	8.17	8.71
<i>a</i> 4	0.06	0.05	0.05	0.10	0.07	0.11
<i>b</i> 4	-0.07	0.20	-0.66	0.75	-0.67	0.77
<i>a</i> 5	-0.06	-0.05	-0.07	-0.02	-0.08	-0.02
<i>b</i> 5	-0.63	-0.60	-0.69	-0.64	-0.76	-0.71
<i>a</i> 6	0.03	0.03	0.02	0.03	0.02	0.03
<i>b</i> 6	0.00	-0.01	-0.02	0.03	-0.03	0.03
<i>a</i> 7	0.03	0.03	0.02	0.00	0.02	0.01
<i>b</i> 7	0.65	0.70	0.57	0.61	0.58	0.61
<i>b</i> 9	0.25	0.26	0.26	0.26	0.21	0.20
<i>b</i> 11	0.73	0.73	0.63	0.62	0.63	0.62

Multipolar errors up to very high order have a significant impact on the nonlinear beam dynamics.

# Sextupole magnets

Nonlinear magnetic fields are introduced in the lattice (chromatic sextupoles)

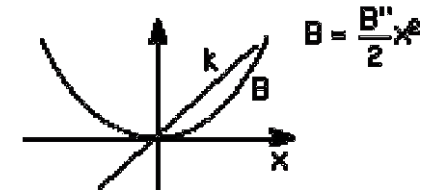
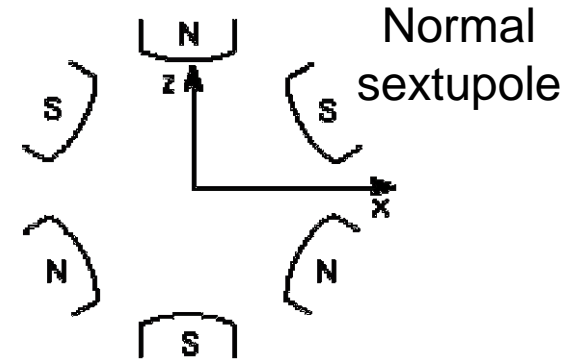
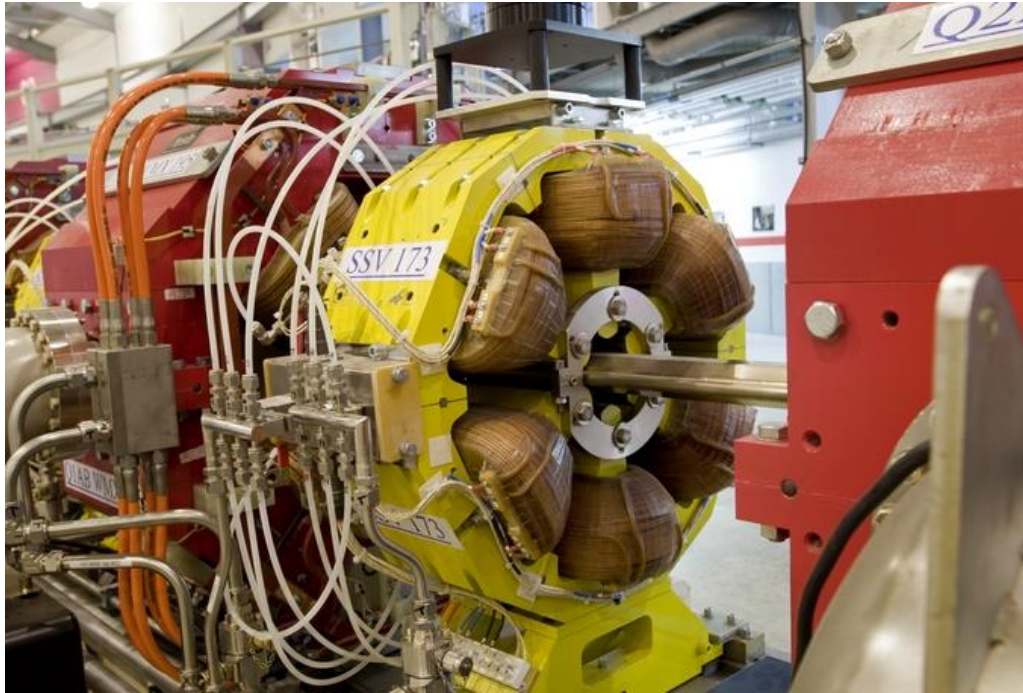

$$B_z = \frac{1}{2} \frac{\partial^2 B_z}{\partial x^2} (x^2 - z^2) \quad \text{Normal sextupole}$$

$$B_z = \frac{1}{2} \frac{\partial^2 B_x}{\partial x^2} \cdot 2xz \quad \text{Skew sextupole}$$

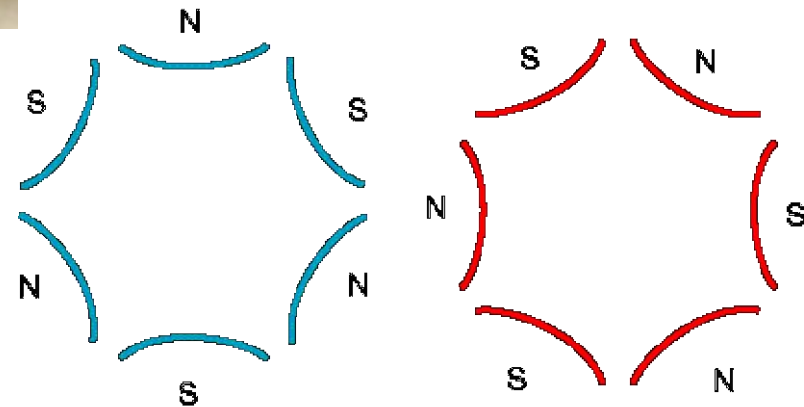

NORMAL 6 POLE

SKEW 6 POLE

# Example: nonlinear elements in small emittance machines

Small emittance  $\rightarrow$  Strong quadrupoles  $\rightarrow$  Large (natural) chromaticity

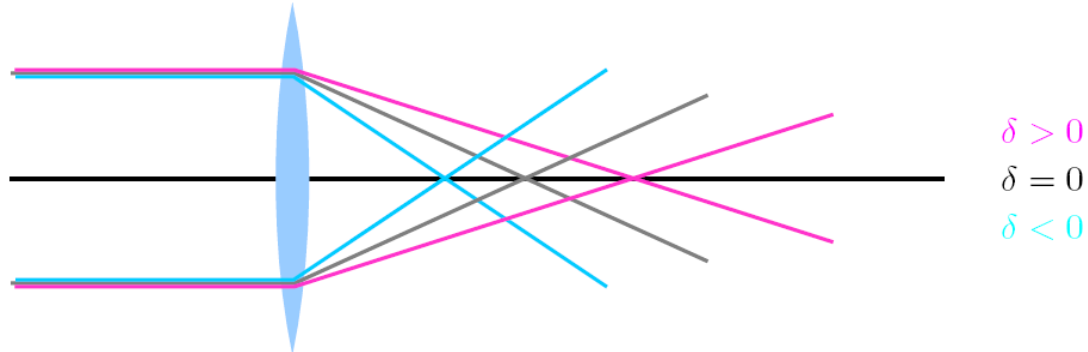

$\rightarrow$  Strong sextupoles (sextupoles guarantee the focussing of off-energy particles)

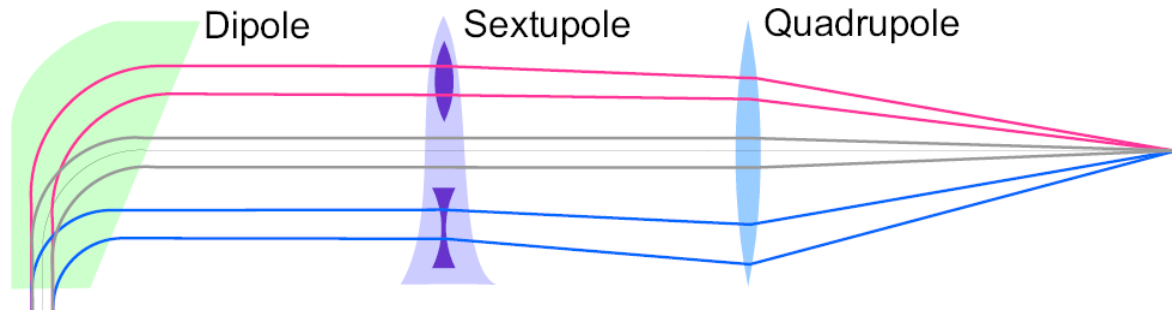

**strong sextupoles have a significant impact on the electron dynamics**

$\rightarrow$  additional sextupoles are required to correct nonlinear aberrations

# Phenomenology of nonlinear motion (I)

The orbit in phase space for a system of **linear Hill's equation** are ellipses (or circles)

The frequency of revolution of the particles is the same on all ellipses

The orbit in the phase space for a system of **nonlinear Hill's equations** are no longer simple ellipses (or circles);

The frequency of oscillations depends on the amplitude

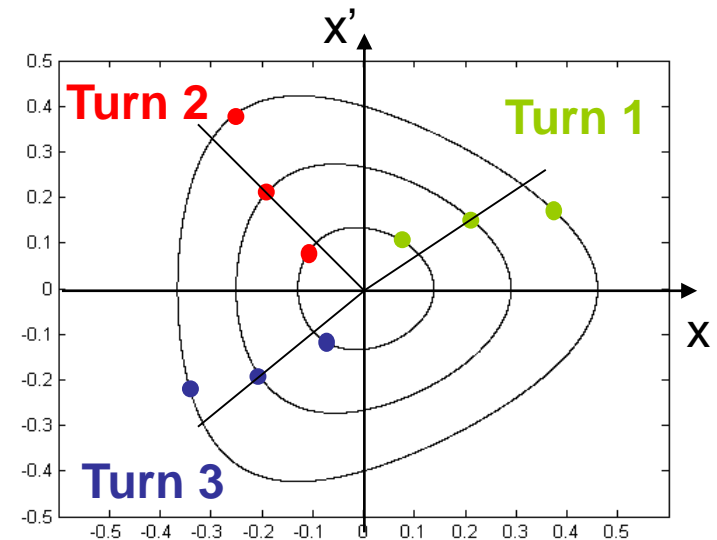
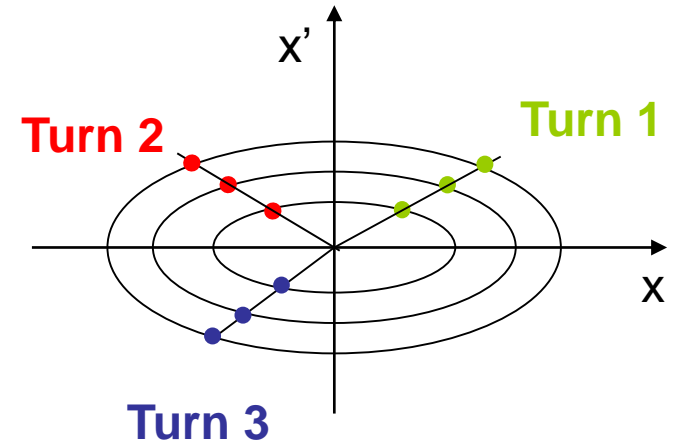



# Resonances

When the betatron tunes satisfy a resonance relation

$$mQ_x + nQ_z = p$$

the motion of the charged particle repeats itself periodically

If there are errors and perturbations which are sampled periodically their effect can build up and destroy the stability of motion

The resonant condition defines a set of lines in the tune diagram

The working point has to be chosen away from the resonance lines, especially the lowest order one

(example CERN-SPS working point)

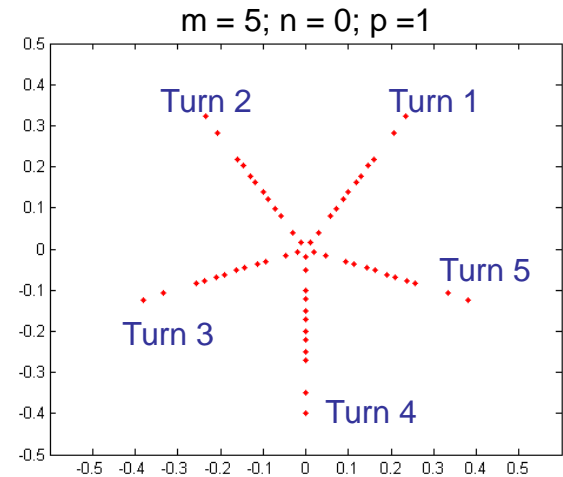

5-th order resonance phase space plot  
(machine with no errors)

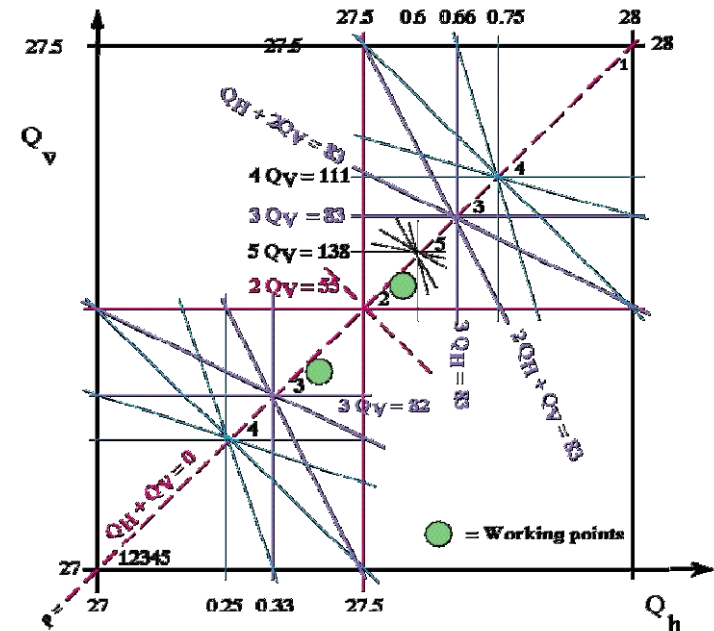

# Phenomenology of nonlinear motion (II)

Stable and unstable fixed points appears which are connected by separatrices

Islands enclose the stable fixed points

On a resonance the particle jumps from one island to the next and the tune is locked at the resonance value

region of chaotic motion appear

The region of stable motion, called **dynamic aperture**, is limited by the appearance of unstable fixed points and trajectories with fast escape to infinity

Phase space plots of close to a 5<sup>th</sup> order resonance

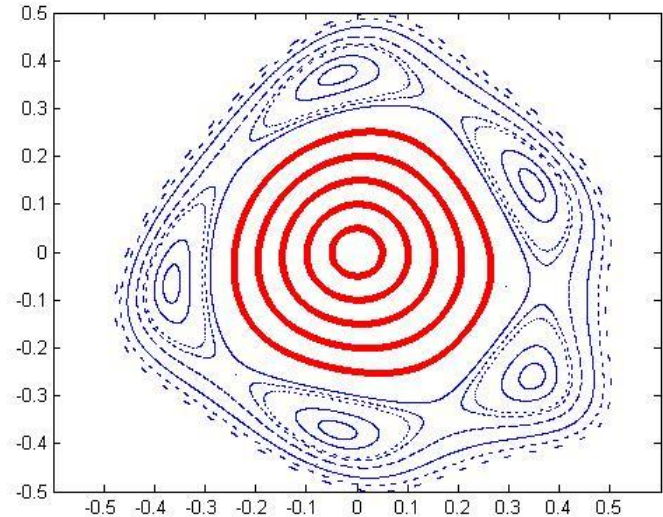

Tune vs amplitude

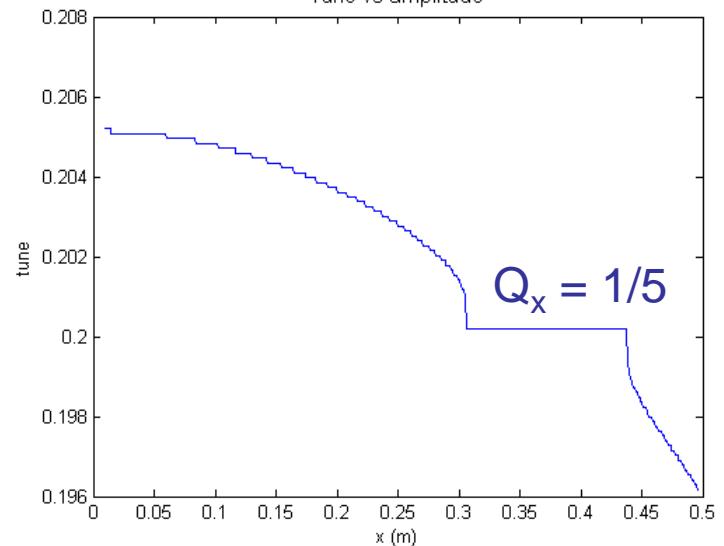

# Phenomenology of nonlinear motion (III)

The orbits in phase space of a non linear system can be broadly divided in

- Regular orbit  $\Rightarrow$  stable or unstable
- Chaotic orbit  $\Rightarrow$  no guarantee for stability but diffusion rate may be very small

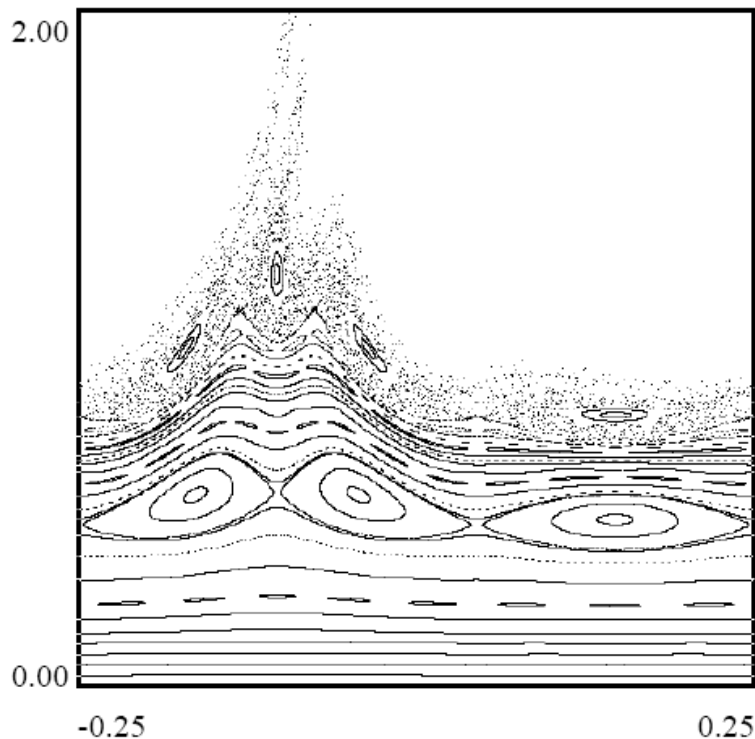

The particle motion on a regular and stable orbit is quasi-periodic

$$z(n) = \sum_{k=1}^n c_k e^{-2\pi i \nu_k n} \quad c_k = a_k e^{i\phi_k}$$

The betatron tunes are the main frequencies corresponding to the peak of the spectrum in the two planes of motion

The frequencies are given by linear combination of the betatron tunes.

Only a finite number of lines appears effectively in the decomposition.

# Phenomenology of nonlinear motion (IV)

An example of the frequency decomposition of the nonlinear motion in the case of a stable regular orbit from Diamond tracking data

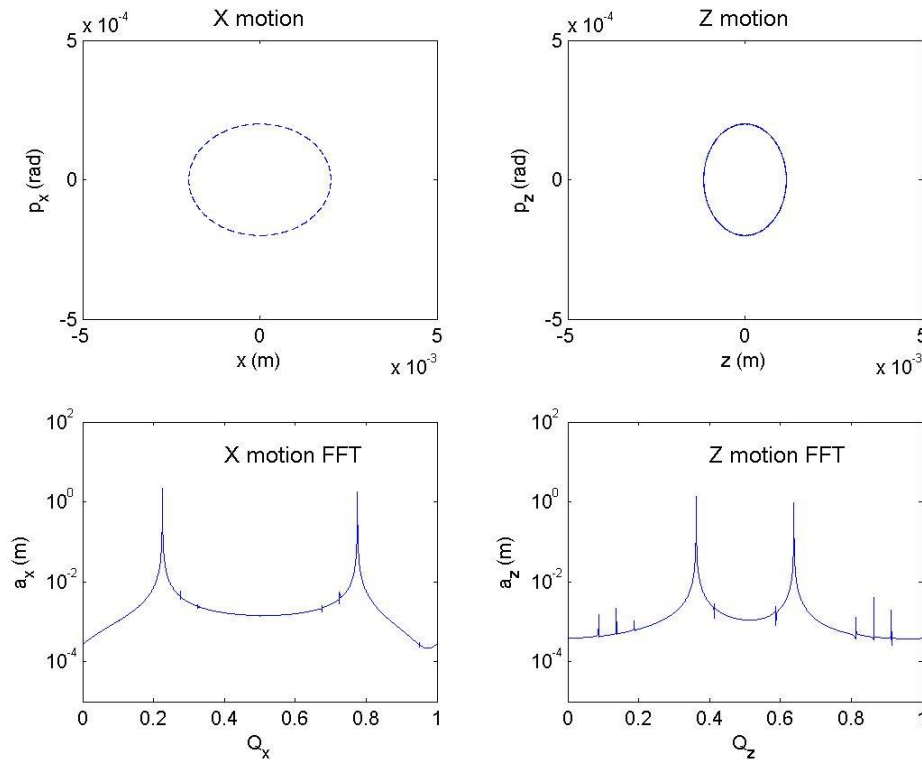

## Spectral Lines detected with a super FFT algorithm

e.g. Horizontal:

- (1, 0)       $1.10 \cdot 10^{-3}$     horizontal tune
- (0, 2)       $1.04 \cdot 10^{-6}$      $Q_x + 2 Q_z$
- (-3, 0)      $2.21 \cdot 10^{-7}$      $4 Q_x$
- (-1, 2)      $1.31 \cdot 10^{-7}$      $2 Q_x + 2 Q_z$
- (-2, 0)      $9.90 \cdot 10^{-8}$      $3 Q_x$
- (-1, 4)      $2.08 \cdot 10^{-8}$      $2 Q_x + 4 Q_z$

If the machine is linear (i.e. only dipole and quadrupole) only the betatron tunes appear in the spectrum. The other lines are generated by the non linear elements

# Phenomenology of nonlinear motion summary

- detuning with amplitude
- orbit distortion
- resonances (fixed points and islands)
- regular stable trajectories (quasi periodic decompositions)
- chaotic trajectories (generally unstable)
- regular unstable trajectories
- limited stable phase space area available to the beam

# Simplified treatment of resonances

A simplified treatment of the resonance can be obtained by considering a single nonlinear element along the ring and looking at its effect on the charged particle motion in phase space:

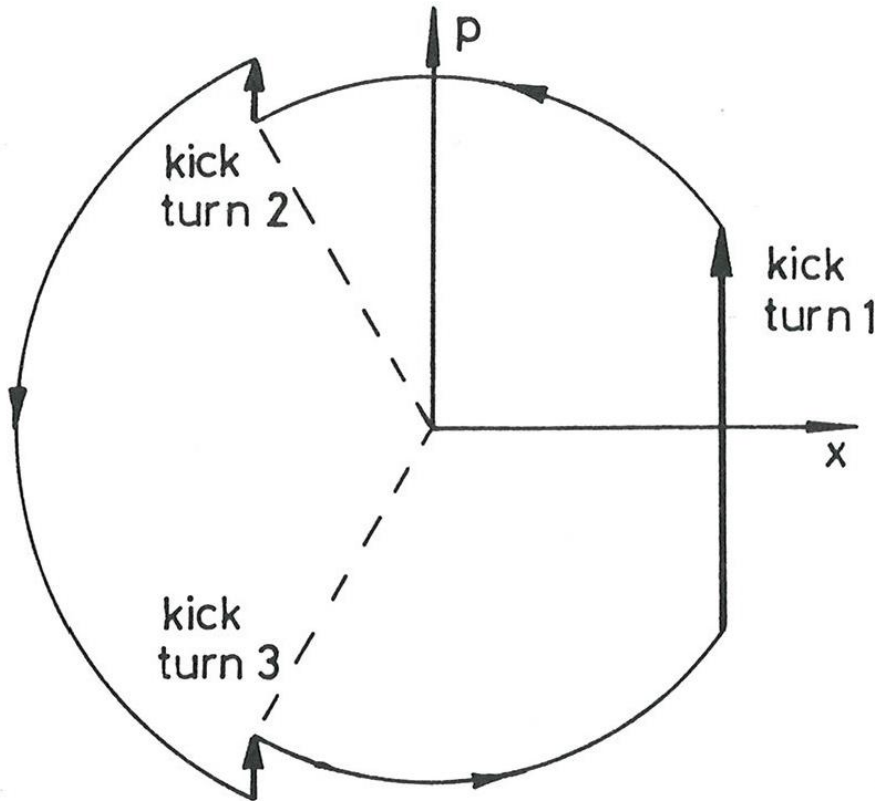

The rest of the ring has no nonlinear element: the motion is just a rotation described by the unperturbed betatron tune  $Q$ , i.e.

$$x = A \cos(\varphi) \quad \varphi = Q\theta$$

and  $\theta$  ( $0 < \theta < 2\pi$ ) is the azimuthal angle along the ring.

When the particle reaches the nonlinear element it receives a kick proportional to the multipolar field error found

$$\Delta p = \frac{\beta L}{B\rho n!} \frac{\partial^n B_y}{\partial x^n} x^n$$

# Example: second order resonance (I)

The effect of the kick can be computed analytically. Assume a quadrupole kick

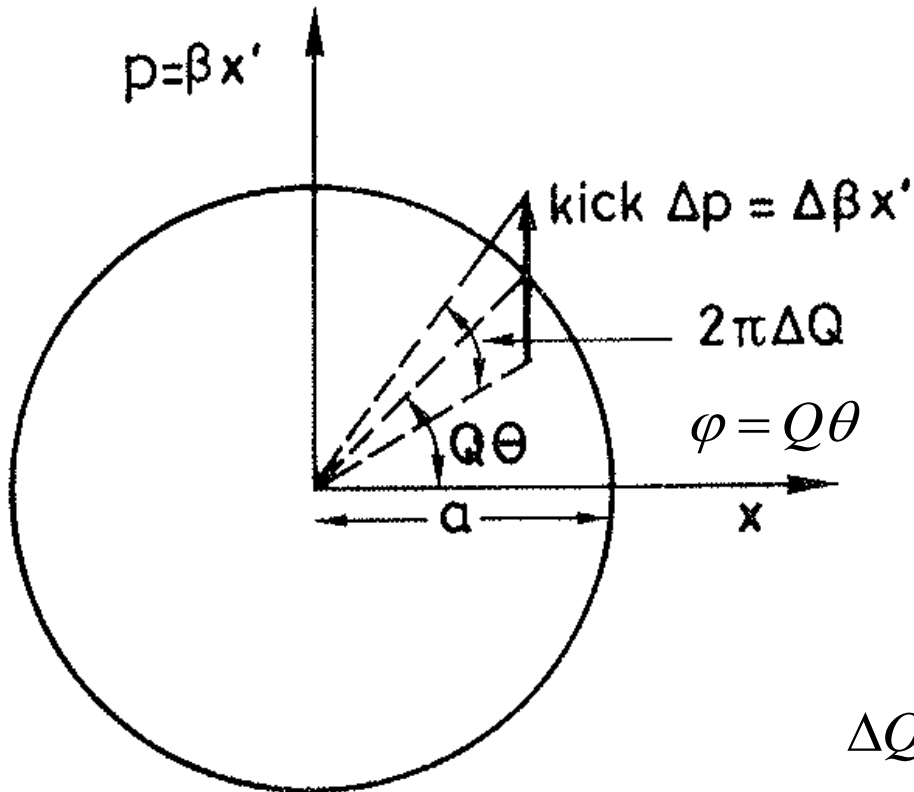

$$\Delta p = \beta \Delta x' = \frac{\beta L \Delta g}{B \rho} x \quad \text{Eq. 1}$$

The kick perturbs the amplitude and the phase

$$\Delta a = \Delta p \sin(\varphi) \quad (\text{radially})$$

$$2\pi\Delta Q = \frac{\Delta p}{a} \cos(\varphi)$$

Substituting in Eq. 1 we obtain

$$\Delta Q = \frac{\beta L \Delta g}{2\pi B \rho} \cos^2(\varphi) = \frac{\beta L \Delta g}{4\pi B \rho} [\cos(2\varphi) + 1]$$

Over one turn the perturbed phase advance is  $\Delta\varphi = 2\pi(Q + \Delta Q)$  and the total phase will become  $\varphi \rightarrow \varphi + 2\pi(Q + \Delta Q)$

## Example: second order resonance (II)

The tune shift due to the kick  $\Delta Q = \frac{\beta L \Delta g}{4\pi B \rho} [\cos(2\varphi) + 1]$  has a constant term

and a term dependent on the phase with which the charged particle meets the perturbing element.

Correspondingly, the perturbed tune  $Q + \Delta Q$  changes at each turn, oscillating around the mean value with

$$\Delta Q = \frac{\beta L \Delta g}{4\pi B \rho} \cos(2\varphi) \quad \text{with an amplitude} \quad \Delta Q_{\max} = \frac{\beta L \Delta g}{4\pi B \rho}$$

If this band contains the half integer resonance, eventually, on a certain turn, the perturbed tune reaches the half integer resonance

$$Q + \Delta Q = \frac{p}{2}$$

This happens when  $\varphi = \varphi_r$

$$Q + \Delta Q = Q + \frac{\beta L \Delta g}{4\pi B \rho} \cos(2\varphi_r) = \frac{p}{2} \quad \text{Eq. 2}$$



# Resonance stopband

When this happens the particle locks to the resonance since, in the subsequent turns, the perturbation to the tune will remain the same and will keep the perturbed tune fixed to the resonant value

$$\varphi_r \rightarrow \varphi_r + 2\pi(Q + \Delta Q) = \varphi_r + 2\pi p/2 = \varphi_r + \pi p$$

and the corresponding change in tune  $\Delta Q = \frac{\beta L \Delta g}{4\pi B \rho} \cos(2\varphi_r + 2\pi p) = \frac{\beta L \Delta g}{4\pi B \rho} \cos(2\varphi_r)$  gives again Eq. 2

We can say that the half integer line has a width

$$\delta Q = \frac{\beta L \Delta g}{4\pi B \rho}$$

called resonance **stopband**.

All particles with tune within the stop band, will end up locked to the resonance

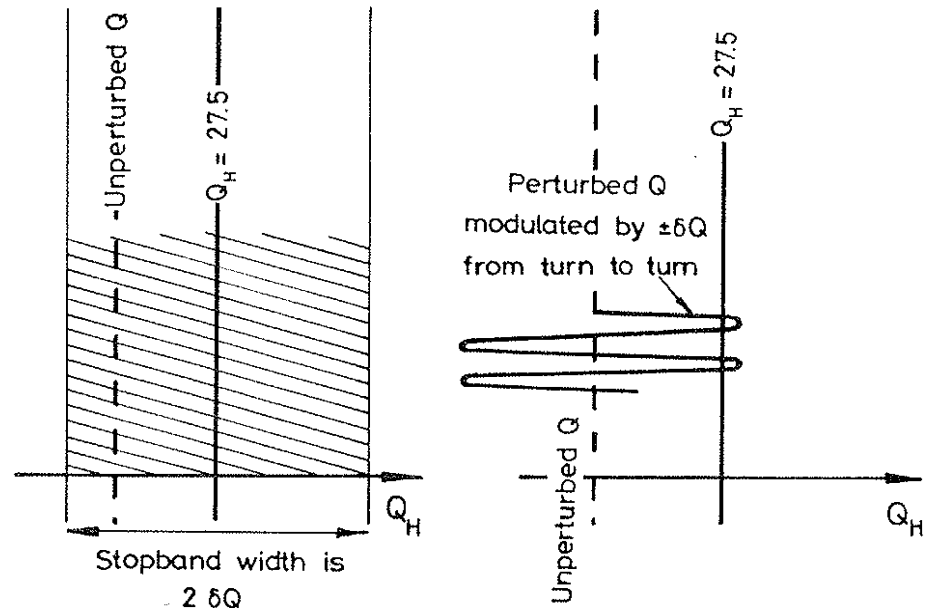

Once the particle is locked to the resonance the trajectory becomes periodic. This situation can lead to particle losses due to the second order resonance

## Example: third order resonance

The kick due to a normal sextupole, can be written as  $\Delta p = \beta \Delta x' = \frac{\beta L B''}{2B\rho} x^2$

Repeating the same procedure we can compute the tune shift due to the sextupole kick as

$$\Delta Q = \frac{\beta L B'' a}{16\pi B\rho} [\cos(3\varphi) + 3\cos(\varphi)]$$

If the tune is close to a third order resonance ( $Q = 1/3$ ), within the stopband given by

$$\Delta Q_{\max} = \frac{\beta L B'' a}{16\pi B\rho}$$

after a sufficient number of turns the tune will lock at the third order resonance, every three turns the motion will repeat identical and the amplitude will grow indefinitely.

Similarly it can be shown that an octupole excites a fourth order resonance, and a  $2n$ -pole excites a  $n$ -th order resonance

# Hamiltonian of a relativistic charged particle in an electromagnetic field

Remember from special relativity that the relativistic momenta are given by

$$p_x = \frac{mV_x}{\sqrt{1 - (v/c)^2}} \quad p_z = \frac{mV_z}{\sqrt{1 - (v/c)^2}} \quad p_s = \frac{mV_s}{\sqrt{1 - (v/c)^2}}$$

and the energy of a free particle is

$$E = \left[ p_x^2 c^2 + p_z^2 c^2 + p_s^2 c^2 + m_0^2 c^4 \right]^{1/2}$$

The Hamiltonian of a charged particle with coordinates  $(x, z, s)$  in an electromagnetic field described by the potentials  $(\bar{A}, \Phi)$ , is obtained by using the generalised particle momentum

$$H(\bar{q}, \bar{p}; t) = e\Phi + c \left[ (\bar{p} - e\bar{A})^2 + m_0^2 c^2 \right]^{1/2}$$

# Hamiltonian for a charged particle in an accelerator

Choosing the reference frame along the reference orbit and measuring transverse deviation with respect to the reference orbit the Hamiltonian reads

$$H(\bar{q}, \bar{p}; t) = e\Phi + c \left[ (p_x - eA_x)^2 + (p_z - eA_z)^2 + \left( \frac{p_s - eA_s}{1 - x/\rho} \right)^2 + m_0^2 c^2 \right]^{1/2}$$

Choosing the Coulomb gauge and ignoring electrostatic fields we can put  $\Phi = 0$

Using  $s$  as independent variable in place of  $t$  the new Hamiltonian reads

$$K(x, p_x, z, p_z, t, -H; s) = -eA_s - \left( 1 + \frac{x}{\rho} \right) \sqrt{\left( \frac{H}{c} \right)^2 - m^2 c^2 - (p_x - eA_x)^2 - (p_z - eA_z)^2}$$

Using the normalised momenta  $\bar{p}_x = \frac{p_x}{p_0} = \frac{p_x}{H/c}$   $\bar{p}_z = \frac{p_z}{p_0} = \frac{p_z}{H/c}$

$$K(x, \bar{p}_x, z, \bar{p}_z, t, -H; s) = -\frac{e}{p_0} A_s - \left( 1 + \frac{x}{\rho} \right) \sqrt{1 - \left( \bar{p}_x - \frac{eA_x}{p_0} \right)^2 - \left( \bar{p}_z - \frac{eA_z}{p_0} \right)^2}$$

## Hamiltonian cont'd

Assuming that the magnetic field is purely transverse  $A_x = A_z = 0$ , i.e. hard edge model with no ends effect, we have

$$K(x, \bar{p}_x, z, \bar{p}_z, t, -H; s) = -\frac{e}{p_0} A_s - \left(1 + \frac{x}{\rho}\right) \sqrt{1 - \bar{p}_x^2 - \bar{p}_z^2}$$

In terms of the multipole expansion of the magnetic field we have

$$\frac{eA_s}{p_0} = \frac{1}{\rho} \left( x + \frac{x^2}{2\rho} \right) - \text{Re} \sum_{n=1}^M (k_n + ij_n) \frac{(x + iz)^{n+1}}{(n+1)!}$$

Assuming small angles  $p_x \ll p_0$ ;  $p_z \ll p_0$  and small radius machines, we have

$$K = \frac{\bar{p}_x^2 + \bar{p}_z^2}{2} - \frac{x^2}{2\rho^2} + \text{Re} \sum_{n=1}^M \frac{k_n + ij_n}{(n+1)!} (x + iz)^{n+1}$$

# Hills' equations from the Hamiltonian

Keeping only lowest order terms (quadratic) in the Hamiltonian, we are left with

$$K = \frac{\bar{p}_x^2 + \bar{p}_z^2}{2} - \frac{x^2}{2\rho(s)^2} + \frac{k_1(s)}{2}(x^2 - z^2)$$

The equations of motions are

$$\frac{dq_x}{ds} = \frac{\partial K}{\partial p_x} \quad \frac{dp_x}{ds} = -\frac{\partial K}{\partial q_x}$$

which combined, coincide with the linear Hill's equations for the betatron motion

$$\frac{d^2 y}{ds^2} + K_y(s)y = 0 \quad K_x(s) = \frac{1}{\rho^2(s)} - k_1(s)$$
$$K_z(s) = k_1(s)$$

# Bibliography

E. Wilson, CAS Lectures 95-06 and 85-19

E. Wilson, Introduction to Particle Accelerators

G. Guignard, CERN 76-06 and CERN 78-11

J. Bengtsson, Nonlinear Transverse Dynamics in Storage Rings, CERN 88-05

J. Laskar et al., The measure of chaos by numerical analysis of the fundamental frequencies, Physica D65, 253, (1992).