

SiPM and Scintillator characterization for highly granular calorimeters

Laszlo Varga (CERN, Eotvos Lorand University HU)

December 10- 11, 2015
CALICE AHCAL Main Meeting



Motivation

- Improve understanding of scintillators and SiPMs and related systematic effects in HCAL and ECAL applications
- Characterize impact of scintillator wrappings and tile size on measured light yield

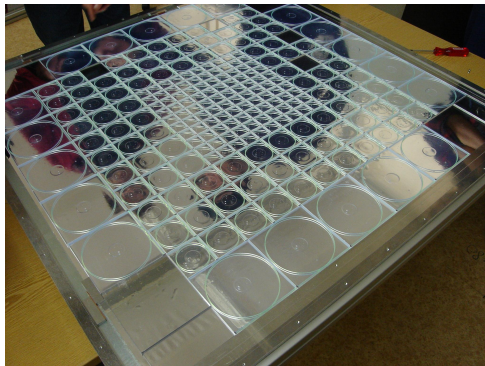

Sensitive layer of the CALICE AHCAL

Calibration of the SiPM: Gain vs. Temperature

Schematic of the Gain vs. Temperature measurement

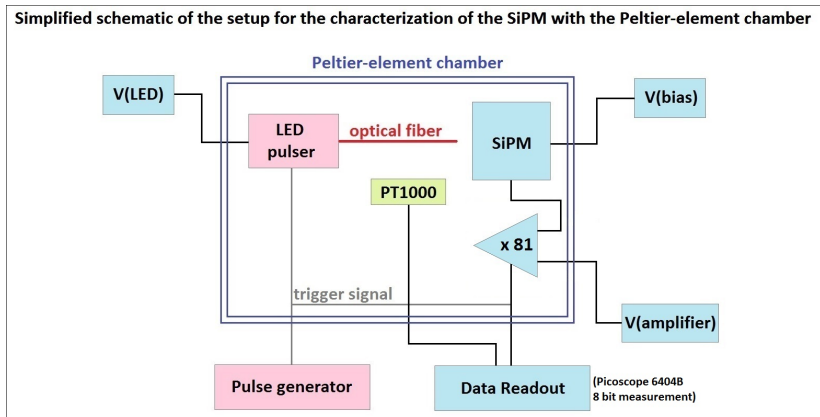

- Optical fiber in front of the SiPM connected to an LED pulser
- Measure SiPM signal from individual photons for gain calibration
- Temperature regulation is done by a thermally isolated Peltier-element chamber with temperature range covering well region of interest [15°C - 30°C]

The interior of the Peltier-element chamber

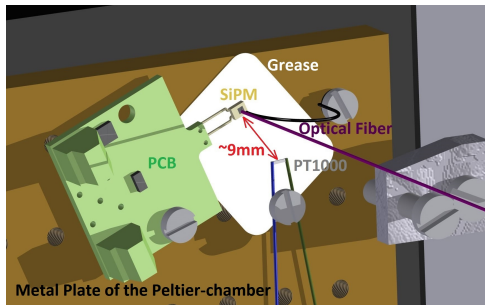
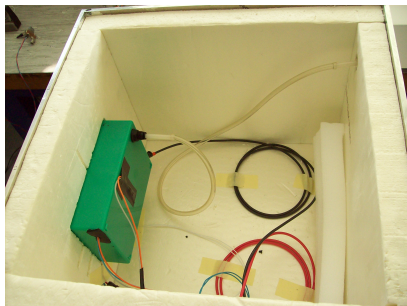

- The temperature of the metal plate inside is adjustable
- Ensure good heat flow between metal plate, SiPM and thermometer (PT1000) by using thermally conductive grease
- The temperature of the SiPM is measured with the PT1000 thermometer
- Temperature of metal plate is measure directly on metal plate

The method of the charge measurement

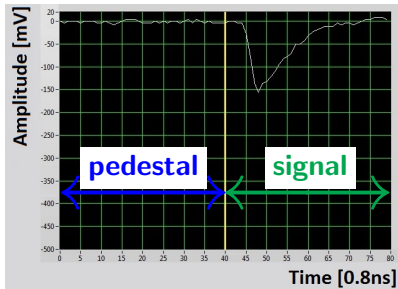

$$\int dt$$

Signal-Pedestal

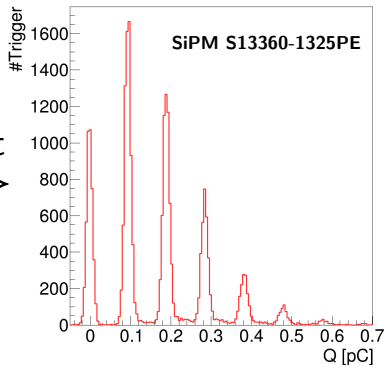

- Two time windows for pedestal and signal measurement
- Convert signal and pedestal response to charge by time integration
- Subtract pedestal from signal event-by-event

The fitting procedure

- Measure the charge of single photons
- Measure T simultaneously
- Fit as many peaks as possible using separate Gaussian functions with correlated parameters:

$$A_{\text{Pois}} \cdot \text{Poisson}(n_{\text{peak}}; \lambda) \cdot \text{Gauss}(x; Q_{\text{PE1}} + i \cdot d; \sigma_i)$$
- d = distance between the peaks
 \Rightarrow Gain (=G)
- Repeat the method for every T values
 \Rightarrow G – T dependence

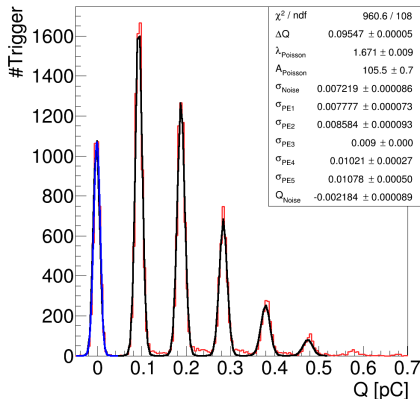

G - T calibration results

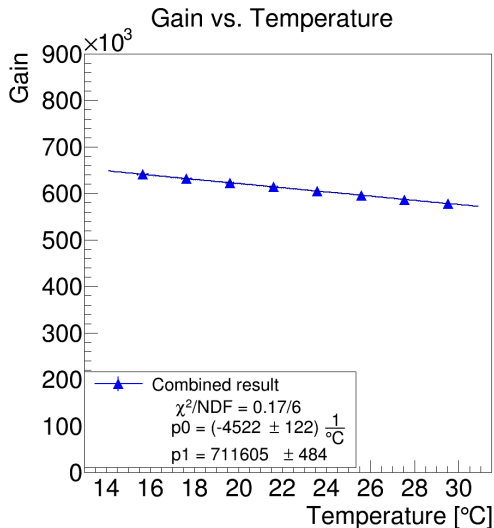

- Scanned a temperature range [15.5°C- 29.5°C] two times (↑ and ↓) with 2°C steps
- Combine the ↑ and ↓ measurements
- Fit G - T with linear function:
 $G(T) = p_0 \cdot T + p_1$
 $\Rightarrow 0.76 \left[\frac{\%}{^\circ\text{C}} \right]$ dependency
- Stable results within < 1% when changing N_{bins} , N_{peaks} , LED settings

Results of the scintillator tile scans

The experimental layout for tile-measurements at CERN

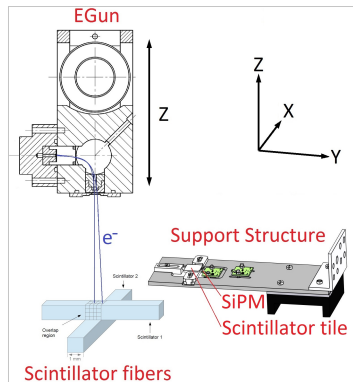
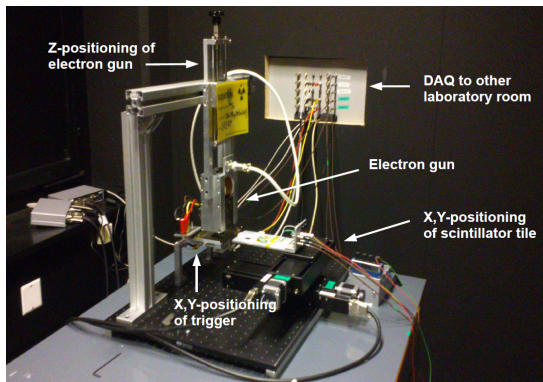

Immediate environment of the scintillator tile

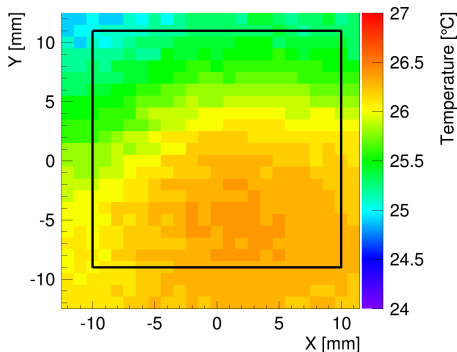
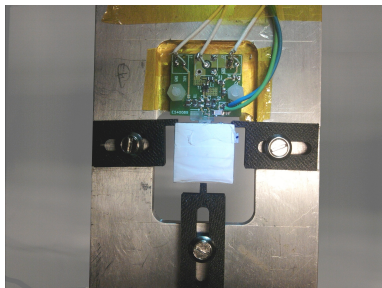

- Use tile support structure with low material close to the tile to avoid signal from stray electrons of the support structure in the tile
- 1 mm step size, 100 s measurement time for each step
- Temperature variation during the measurement $\sim 2^\circ\text{C}$
 - ⇒ influence on the SiPM gain $\sim 1.5\%$
 - ⇒ correct the temperature to $T_{\text{ref}} = 25^\circ\text{C}$

Scanned tile set

Wrapped tiles

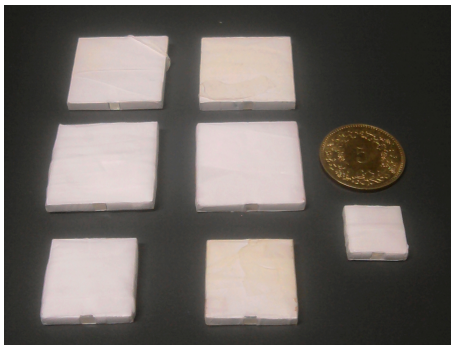

Painted tiles

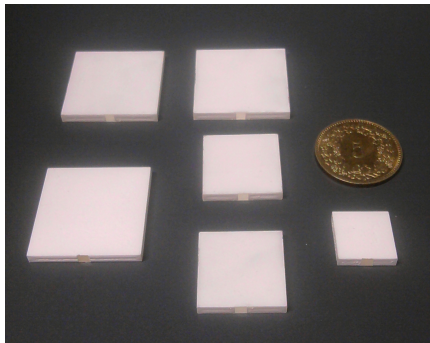

- coating:
 - ⇒ wrapping (3M foil)
 - ⇒ reflection paint

- size:
 - ⇒ $\square 20 \times 2 \text{ mm}^3$
 - ⇒ $\square 15 \times 2 \text{ mm}^3$
 - ⇒ $\square 10 \times 2 \text{ mm}^3$

Regions of a tile scan

e^- beam is $\sim 1\text{mm}^2$

\Rightarrow 3 regions depending on the beam position:

- e^- beam outside of the tile
- e^- beam on the tile edge
- e^- beam inside of the tile

B1W20 - Trigger map

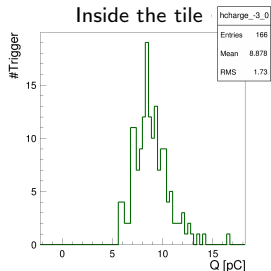
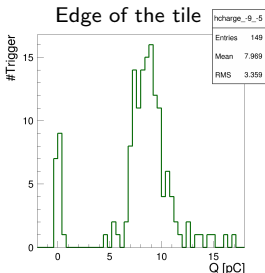
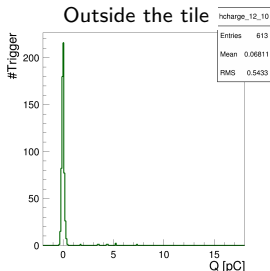
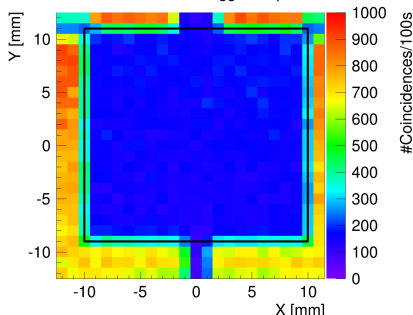

Regions of a tile scan

e^- beam is $\sim 1\text{mm}^2$

\Rightarrow 3 regions depending on the beam position:

- e^- beam outside of the tile
- e^- beam on the tile edge
- e^- beam inside of the tile

Remove events with charge similar to $Q_{\text{ped. subwindow}}$

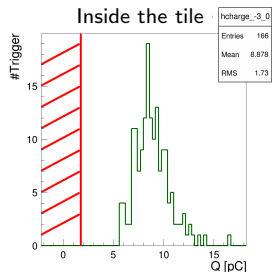
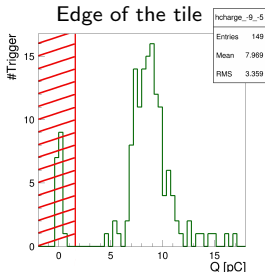
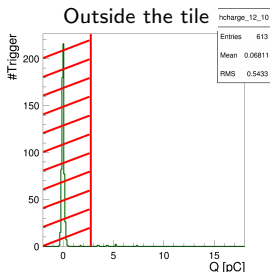
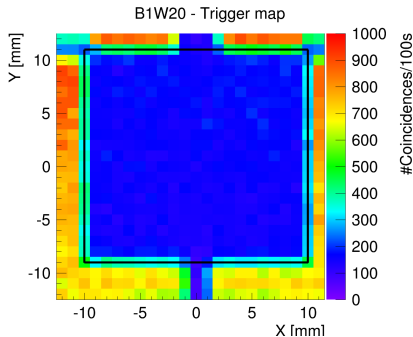

Evaluation of the tile scans

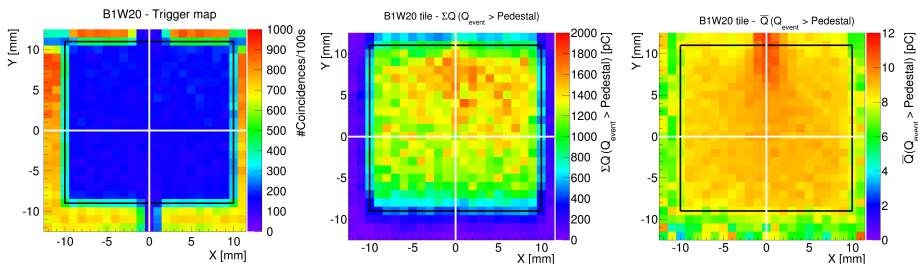

- 3 types of map from the scanned area:
 - ⇒ Trigger map: Locate the edges of a tile
 - ⇒ Sum of the charge map: Investigate the edge effects and the uniformity
 - ⇒ Mean of the charge map: Compare the light yield of the tiles and study the systematic uncertainties
- Slice the tiles in the middle in x and y directions

Slices of all wrapped tiles

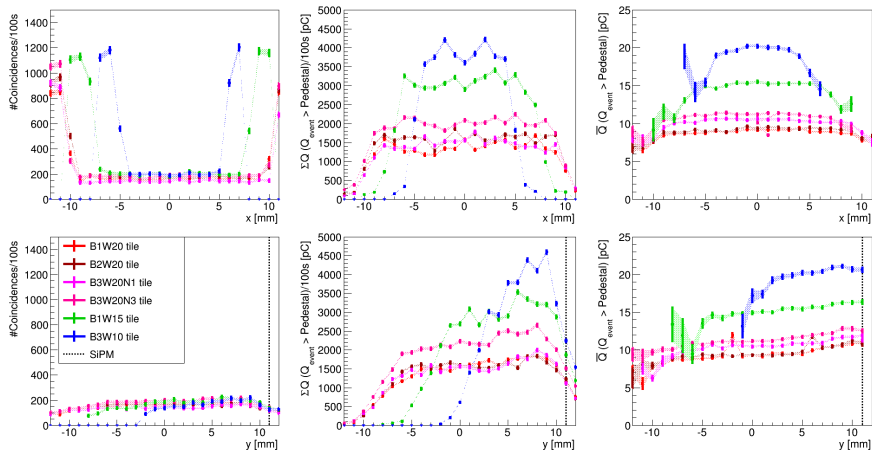

- The light yield scales with the sizes of the tile (\sim SiPM area to tile front area)
- The light yields of the wrapped tiles of same size differ to each other by 20%

Slices of all painted tiles

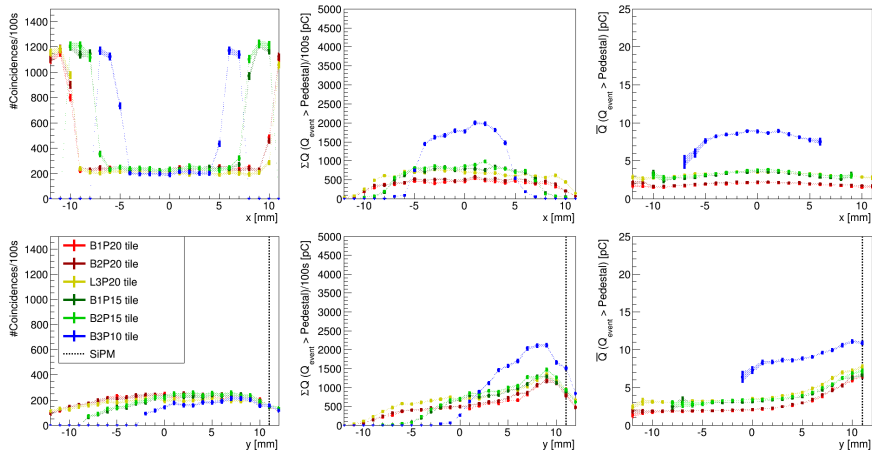

- The light yield of the painted tiles is $\sim 4-5$ times lower than for wrapped tiles
- The light yield is more similar for painted tiles of same size (within 7%) than for wrapped tiles (20%)

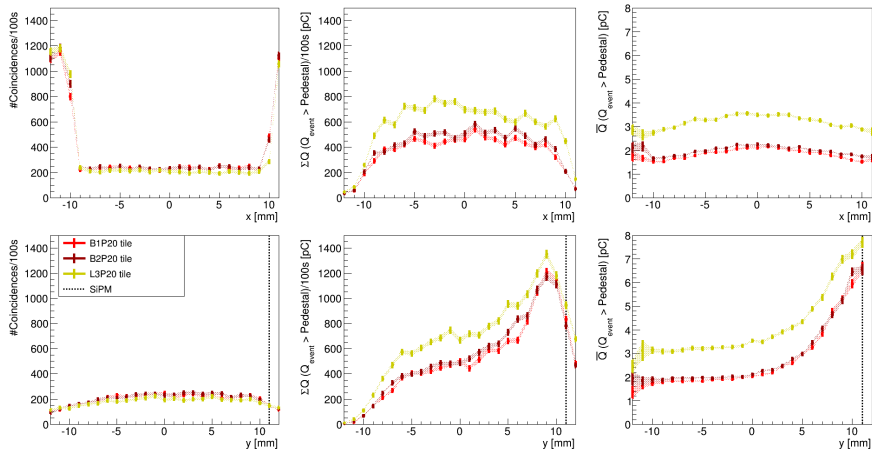
Slices of $20 \times 20 \text{ mm}^2$ painted tiles

- The light yield of the painted tiles can be increased by using thicker painting:
 - ⇒ 2 layers of painting
 - ⇒ 3 layers of painting (50% more light yield)

Summary and Outlook

- Gain-temperature calibration

- ⇒ Controlled temperature with Peltier-element chamber [15.5°C- 29.5°C]
- ⇒ Ensured good heat flow between all components using thermal grease
- ⇒ Calibrated gain as a function of temperature and studied systematic uncertainties

- Tile scans

- ⇒ The light yield of the wrapped tile is $\sim 4-5$ times higher than for the painted tile independent of the size
- ⇒ The light yield scales with the sizes of the tile (\sim SiPM area to tile front area)
- ⇒ The light yield is more similar for painted tiles of same size (within 7%) than for wrapped tiles (20%)
- ⇒ The light yield of the wrapped tiles is more homogeneous than the painted tiles
- ⇒ The light yield of the painted tiles can be increased using thicker painting

- Outlook

- ⇒ Connection between T dependence of gain and tile scan measurements
- ⇒ Multi-tile scans with 2 or 4 tiles of different sizes
- ⇒ Comparison of different SiPMs (pitch, type)

Thank you for your attention!

Reminder: The SiPM

- Silicon Photomultipliers (SiPMs) are photon sensitive devices built from an avalanche photodiode array on common Si substrate
 - The gain (G) of a SiPM depends on the temperature (T)
 - For a correct signal reconstruction, the temperature dependence needs to be known \rightarrow Gain-Temperature calibration
 - Gain can be estimated using well-defined signal from single photons
-
- Hamamatsu MPPC:
 - 1.3x1.3 mm² effective photonsensitive area
 - 2668 pixels, 25 μ m pixel size
 - Type No.: S13360-1325PE
 - Serial No.: 10036

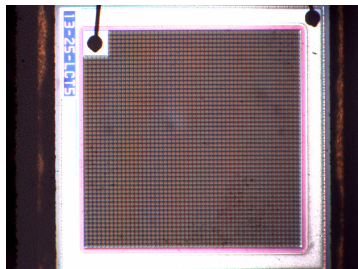

Rendered setup at September 2015

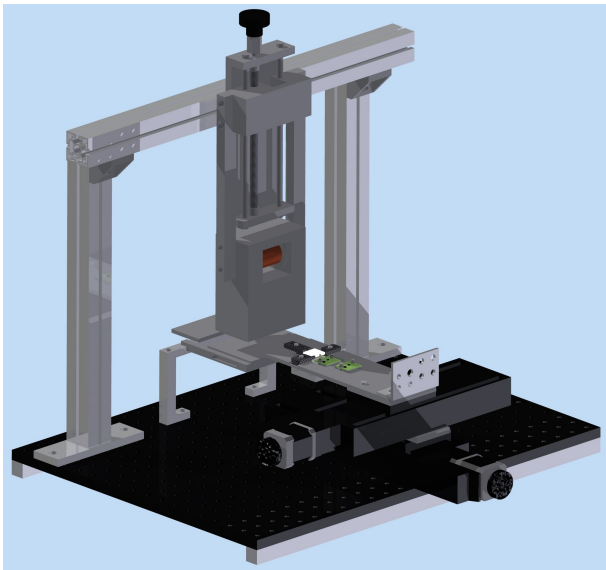

Setup at November 2014

- At the beginning:
use "high-material" tile holders to hold the scintillator in place
- The #Trigger map shows the transparency of the support structure
- Even if the electron beam does not hit the scintillator, stray particles produced in the tile holders leak into scintillator resulting in a measurable signal

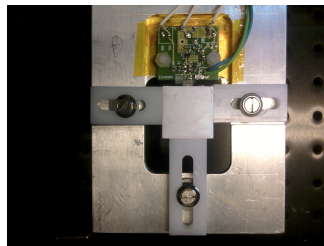

#Trigger map of a tilescan

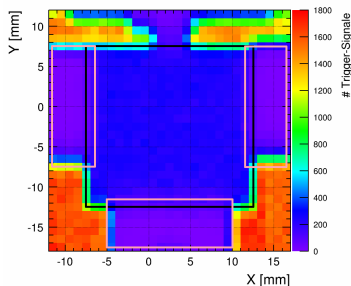

\bar{Q} map of a scintillator tile

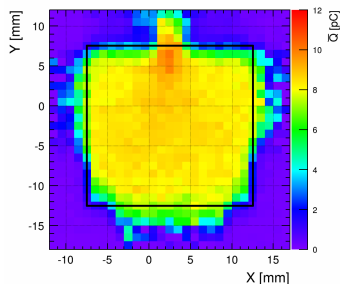

Inside of the Peltier-element chamber

