



The beam current is the basic quantity of the beam.

- It is the first check of the accelerator functionality
- It has to be determined in an absolute manner
- Important for transmission measurement and to prevent beam losses.

Different devices are used:

- **Transformers:** Measurement of the beam's **magnetic field**

They are non-destructive. No dependence on beam energy

They have lower detection threshold.

- **Faraday cups:** Measurement of the beam's **electrical charges**

They are destructive. For low energies only

Low currents can be determined.

- **Particle detectors:** Measurement of the particle's **energy loss** in matter

Examples are scintillators, ionization chambers, secondary e⁻ emission monitors

Used for low currents at high energies e.g. for slow extraction from a synchrotron.

Beam Structure of a pulsed LINAC



Pulsed LINACs and cyclotrons used for injection to synchrotrons with $t_{pulse} \approx 100 \mu s$:

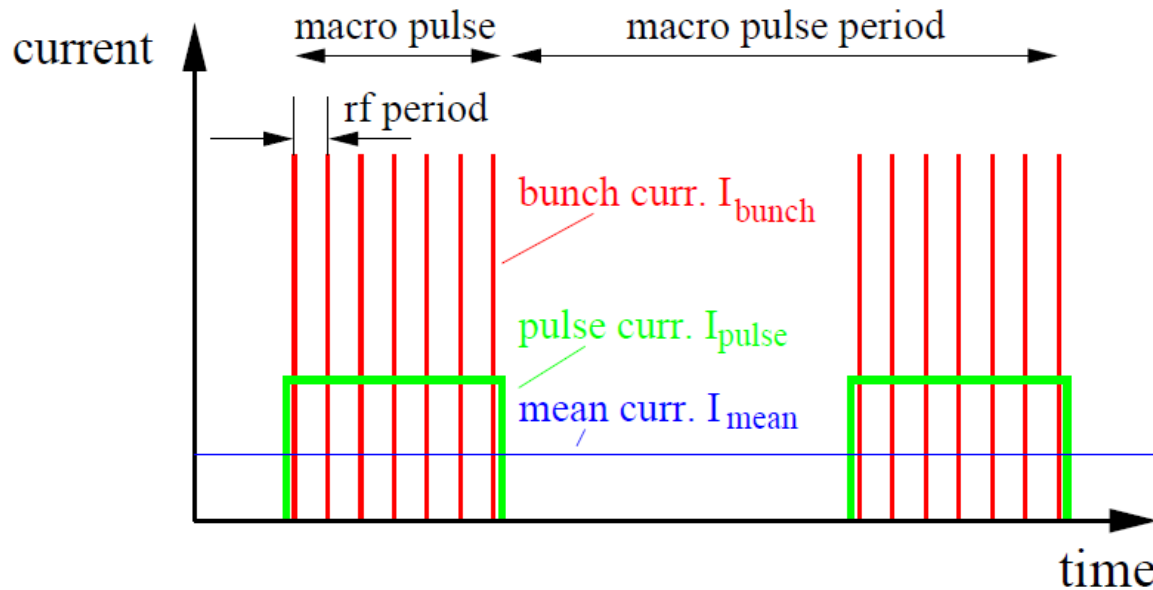

One distinguish between:

- Mean current I_{mean}
→ long time average in [A]
- Pulse current I_{pulse}
→ during the macro pulse in [A]
- Bunch current I_{bunch}
→ during the bunch in [C/bunch]
or [particles/bunch]

Remark: Van-de-Graaff (ele-static):
→ no bunch structure

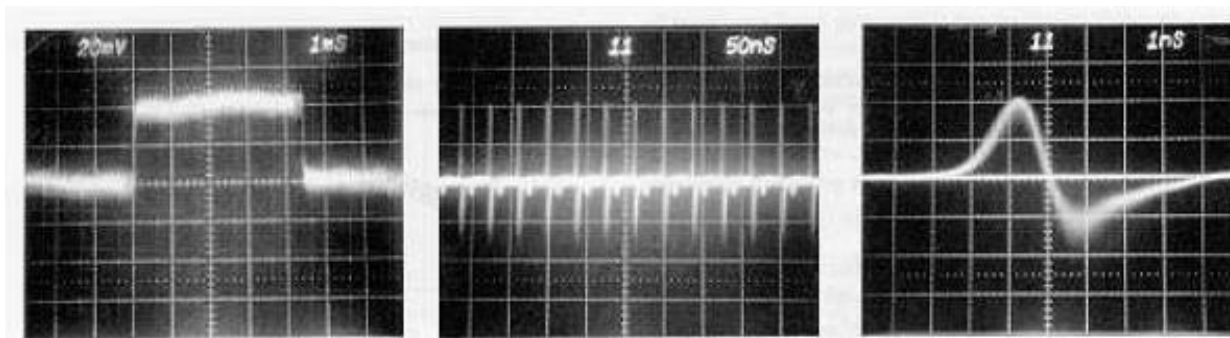

Example:
Pulse and bunch structure at GSI LINAC:

Magnetic field of the beam and the ideal Transformer



➤ Beam current of N_{part} charges with velocity β

$$I_{beam} = qe \cdot \frac{N_{part}}{t} = qe \cdot \beta c \cdot \frac{N_{part}}{l}$$

➤ cylindrical symmetry

→ only azimuthal component

$$\vec{B} = \mu_0 \frac{I_{beam}}{2\pi r} \cdot \vec{e}_\varphi$$

Example: $I = 1\mu\text{A}$, $r = 10\text{cm} \Rightarrow B_{beam} = 2\text{pT}$, earth $B_{earth} = 50\mu\text{T}$

Idea: Beam as primary winding and sense by sec. winding.

⇒ Loaded current transformer

$$I_1/I_2 = N_2/N_1 \Rightarrow I_{sec} = 1/N \cdot I_{beam}$$

➤ Inductance of a torus of μ_r

$$L = \frac{\mu_0 \mu_r}{2\pi} \cdot l N^2 \cdot \ln \frac{r_{out}}{r_{in}}$$

➤ Goal of Torus: Large inductance L and guiding of field lines.

Definition: $U = L \cdot dI/dt$

magnetic field B
at radius r:

$$B \sim 1/r$$

$$\vec{B} \parallel \vec{e}_\varphi$$

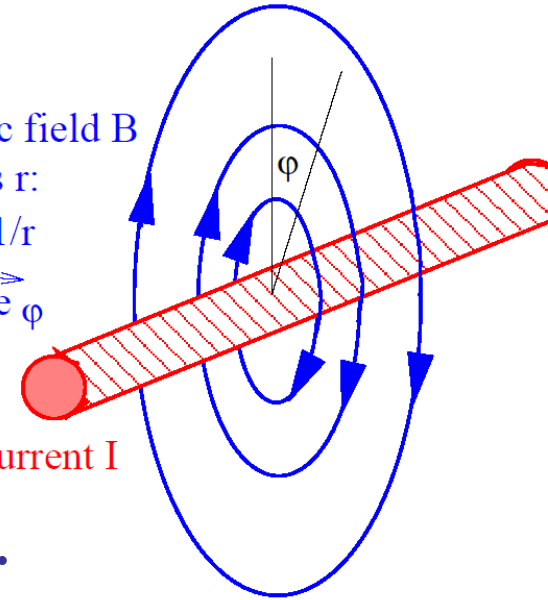

beam current I

Torus to guide the magnetic field

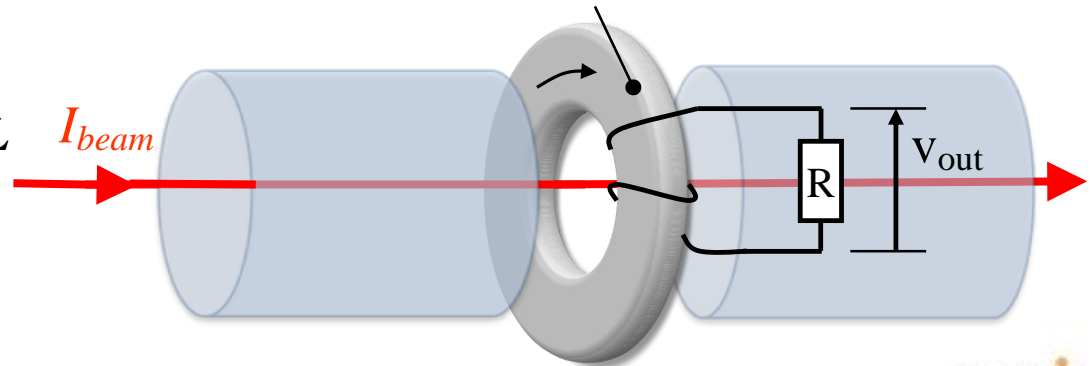

Passive Transformer (or Fast Current Transformer FCT)



Simplified electrical circuit of a passively loaded transformer:

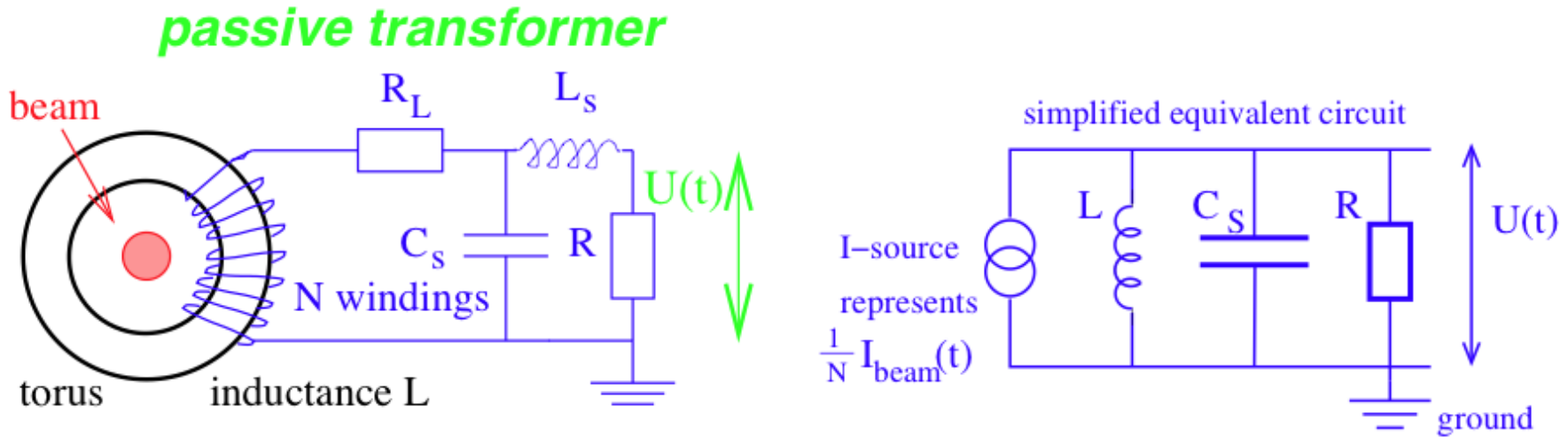

A voltage is measured: $U = R \cdot I_{sec} = R / N \cdot I_{beam} \equiv S \cdot I_{beam}$

with **S sensitivity** [V/A], equivalent to transfer function or transfer impedance **Z**

Equivalent circuit for analysis of sensitivity and bandwidth

(disregarding the loss resistivity R_L)

Bandwidth of a Passive Transformer



Analysis of a simplified electrical circuit of a passively loaded transformer: *passive transformer*

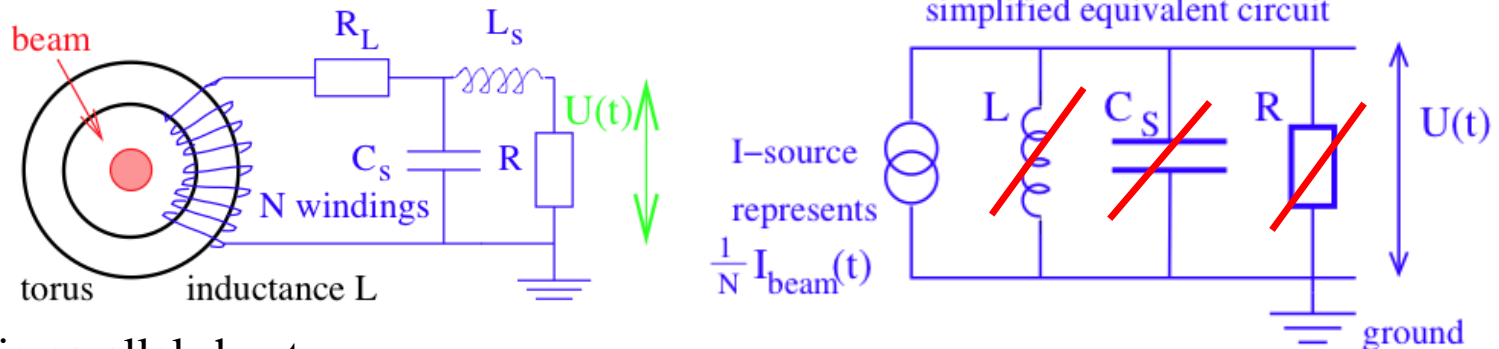

For this parallel shunt:

$$\frac{1}{Z} = \frac{1}{i\omega L} + \frac{1}{R} + i\omega C_S \Leftrightarrow Z = \frac{i\omega L}{1 + i\omega L/R - \omega L/R \cdot \omega R C_S}$$

➤ **Low frequency** $\omega \ll R/L$: $Z \rightarrow i\omega L$

i.e. no dc-transformation

➤ **High frequency** $\omega \gg 1/RC_S$: $Z \rightarrow 1/i\omega C_S$

i.e. current flow through C_S

➤ **Working region** $R/L < \omega < 1/RC_S$: $Z \approx R$

i.e. voltage drop at R and sensitivity $S=R/N$.

No oscillations due to over-damping by low $R = 50 \Omega$ to ground.

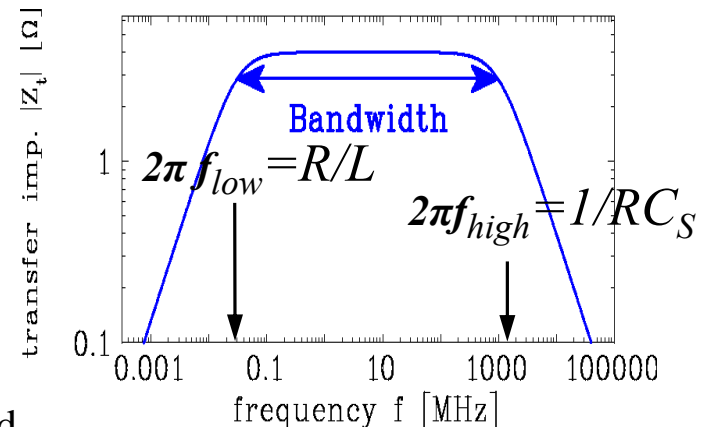

Response of the Passive Transformer: Rise and Droop Time



Time domain description:

Droop time: $\tau_{droop} = 1/(2\pi f_{low}) = L/R$

Rise time: $\tau_{rise} = 1/(2\pi f_{high}) = 1/RC_S$ (ideal without cables)

Rise time: $\tau_{rise} = 1/(2\pi f_{high}) = \sqrt{L_S C_S}$ (with cables)

R_L : loss resistivity, R : for measuring.

For the working region the voltage output is

$$U(t) = \frac{R}{N} \cdot e^{-t/\tau_{droop}} \cdot I_{beam}$$

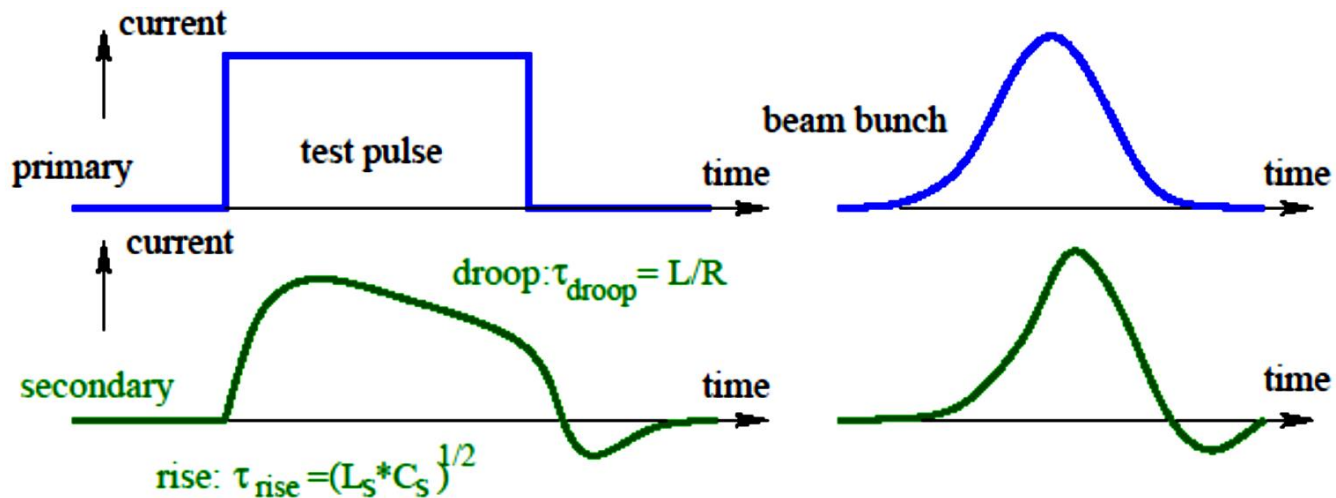
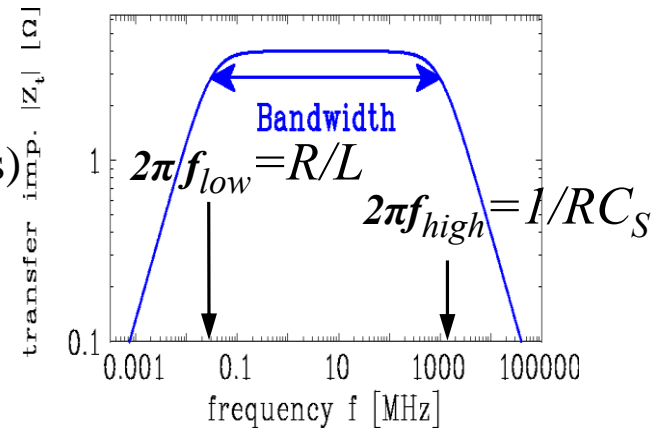

Example for passive Transformer

For bunch observation

e.g. transfer between synchrotrons
a bandwidth of $2 \text{ kHz} < f < 1 \text{ GHz}$

$\Leftrightarrow 1 \text{ ns} < t < 200 \text{ } \mu\text{s}$ is well suited.

Example GSI type:

Inner radius	$r_i = 70 \text{ mm}$
Outer radius	$r_o = 90 \text{ mm}$
Torus thickness	$l = 16 \text{ mm}$
Torus material	Vitrovac 6025: (CoFe) _{70%} (MoSiB) _{30%}
Permeability	$\mu_r \simeq 10^5$ for $f < 100 \text{ kHz}$, $\mu_r \propto 1/f$ above
Windings	10
Sensitivity	4 V/A at $R = 50 \text{ } \Omega$, 10^4 V/A with ampl.
Resolution	$40 \text{ } \mu\text{A}_{rms}$
$\tau_{droop} = L/R$	0.2 ms
$\tau_{rise} = \sqrt{L_S C_S}$	1 ns
Bandwidth	2 kHz to 300 MHz

From
Company Bergoz



Fast extraction from GSI synchrotron:

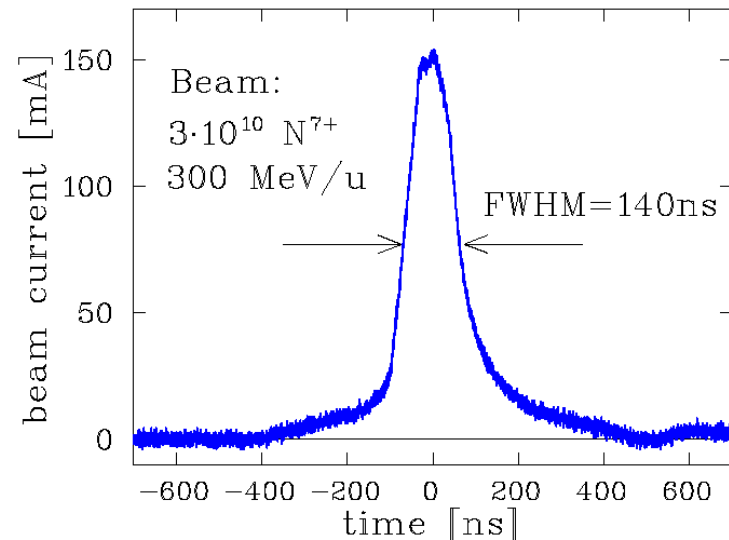

'Active' Transformer with longer Droop Time



Active Transformer or Alternating Current Transformer ACT:

uses a trans-impedance amplifier (I/U converter) to $R \approx 0 \Omega$ load impedance i.e. a current sink
+ compensation feedback
 \Rightarrow longer droop time τ_{droop}

Application: measurement of longer $t > 10 \mu\text{s}$ e.g. at pulsed LINACs

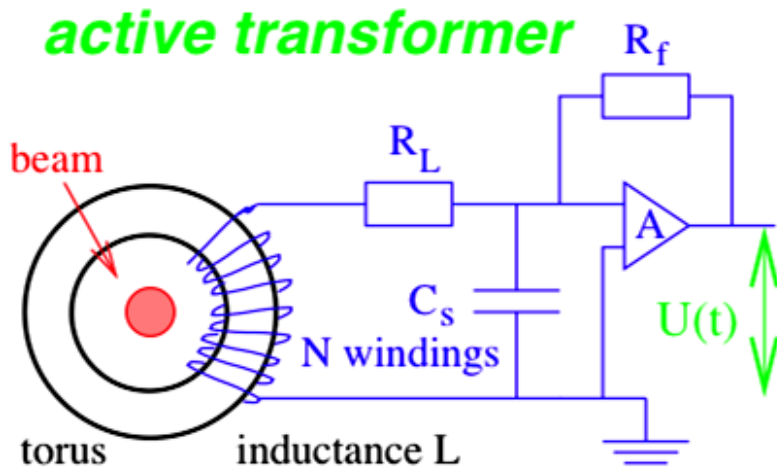

The input resistor is for an op-amp: $R_f/A \ll R_L$

$$\Rightarrow \tau_{droop} = L/(R_f/A + R_L) \approx L/R_L$$

Droop time constant can be up to 1 s!

The feedback resistor is also used for range switching.

An additional active feedback loop is used to compensate the droop.

'Active' Transformer Realization



Active transformer for the measurement of long $t > 10 \mu\text{s}$ pulses e.g. at pulsed LINACs



Torus inner radius	$r_i=30 \text{ mm}$
Torus outer radius	$r_o=45 \text{ mm}$
Core thickness	$l=25 \text{ mm}$
Core material	Vitrovac 6025 $(\text{CoFe})_{70\%}(\text{MoSiB})_{30\%}$
Core permeability	$\mu_r=10^5$
Number of windings	2x10 crossed
Max. sensitivity	10^6 V/A
Beam current range	10 μA to 100 mA
Bandwidth	1 MHz
Droop	0.5 % for 5 ms
rms resolution	0.2 μA for full bw

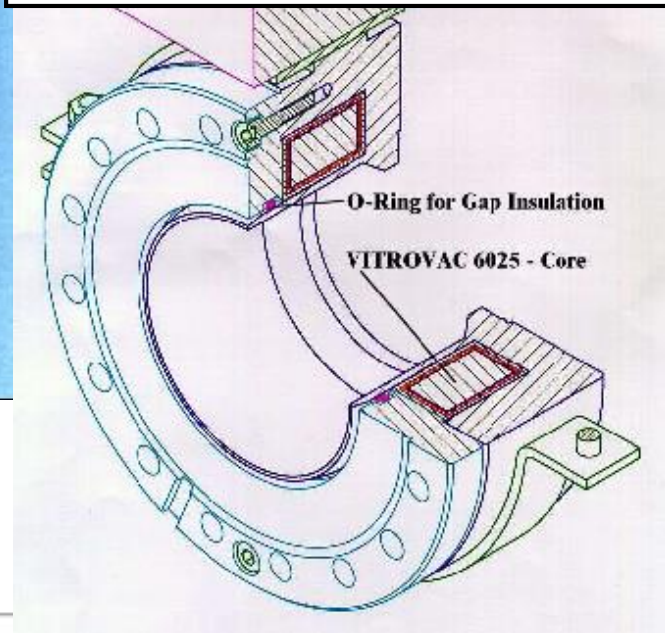

'Active' Transformer Measurement



Active transformer for the measurement of long $t > 10 \mu\text{s}$ pulses e.g. at pulsed LINACs

Example: Transmission and macro-pulse shape for Ni^{2+} beam at GSI LINAC

Example: Multi-turn injection of a Ni^{26+} beam into GSI Synchrotron, $5 \mu\text{s}$ per turn

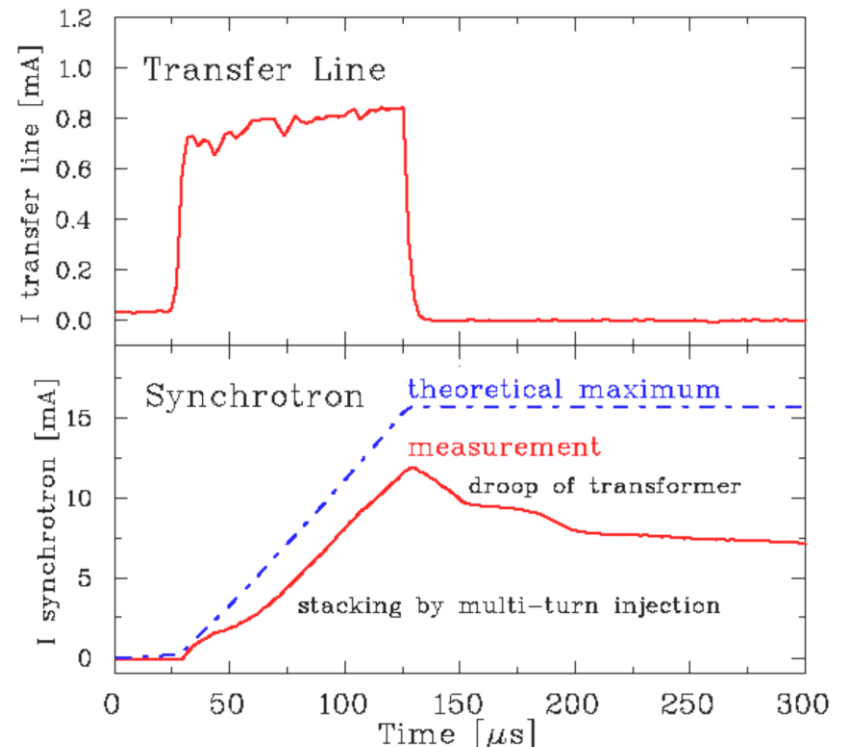
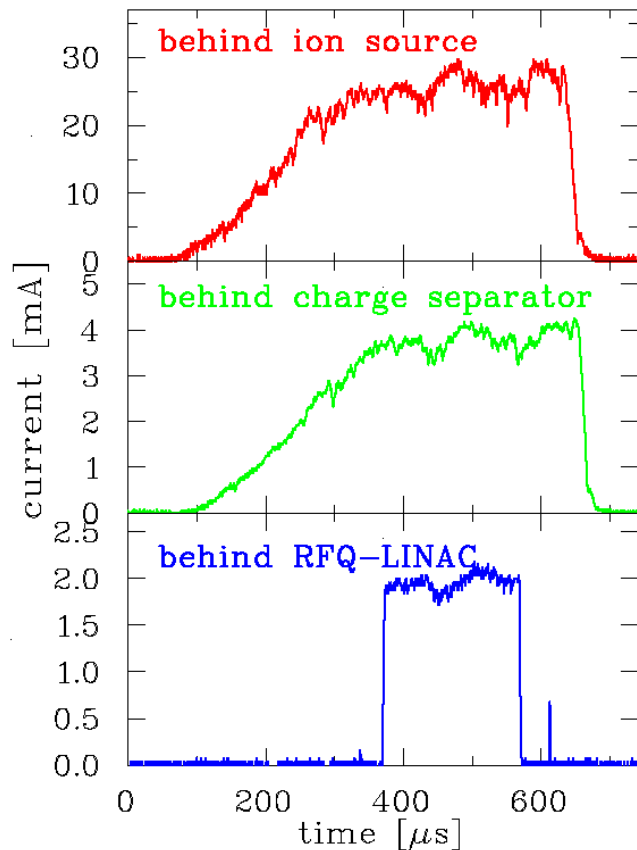

Shielding of a Transformer

Task of the shield:

- The image current of the walls have to be bypassed by a gap and a metal housing.
- This housing uses μ -metal and acts as a shield of external B-field
(remember: $I_{beam} = 1 \mu\text{A}$, $r = 10 \text{ cm} \Rightarrow B_{beam} = 2\text{pT}$, earth field $B_{earth} = 50 \mu\text{T}$)

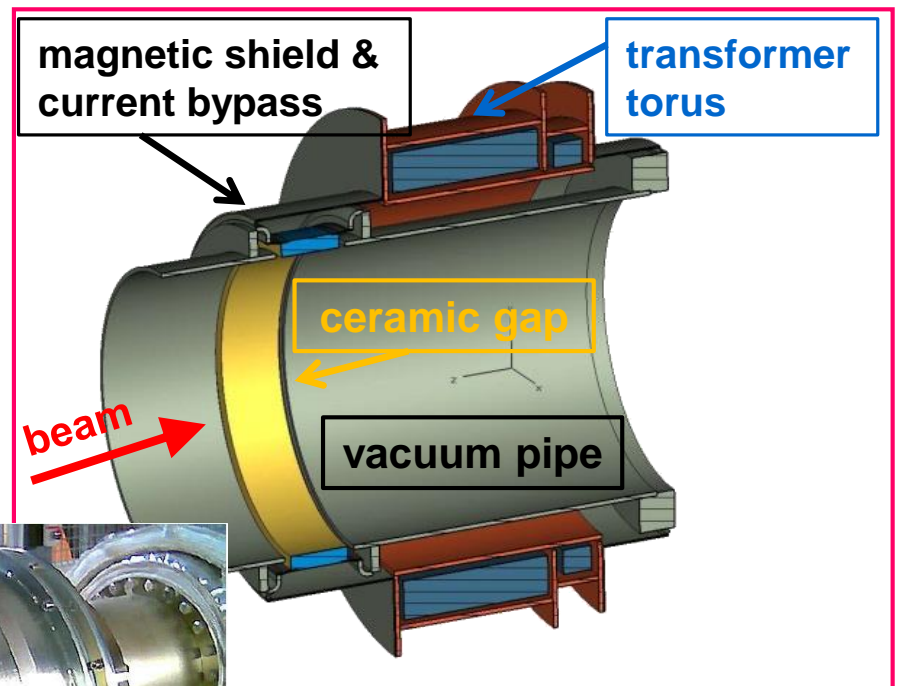
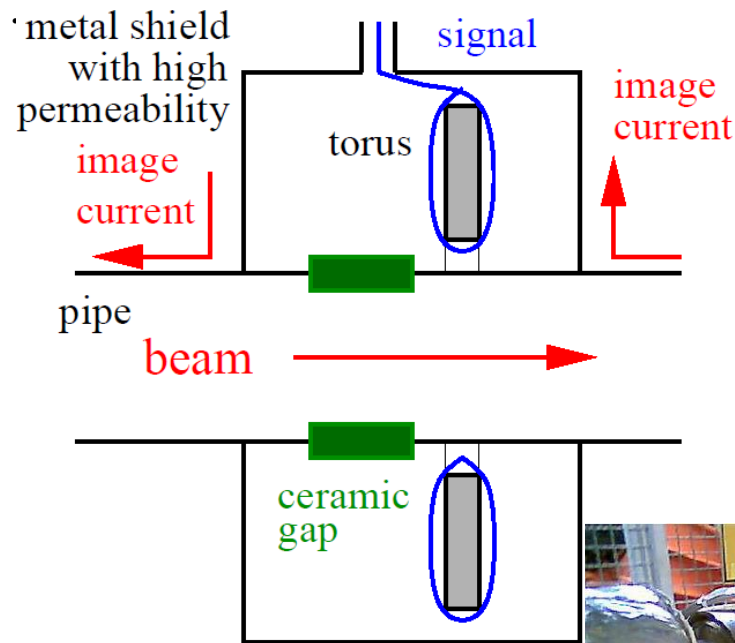

Design Criteria for a Current Transformer



Criteria:

1. The output voltage is $U \propto I/N \Rightarrow$ low number of windings for large signal.
2. For a low droop, a large inductance L is required due to $\tau_{droop} = L/R$:
 $L \propto N^2$ and $L \propto \mu_r$ ($\mu_r \approx 10^5$ for amorphous alloy)
3. For a large bandwidth the integrating capacitance C_s should be low $\tau_{rise} = \sqrt{L_s C_s}$

Depending on applications the behavior is influenced by external elements:

➤ **Passive transformer:** $R = 50 \Omega$, $\tau_{rise} \approx 1$ ns for short pulses

Application: Transfer between synchrotrons : $100 \text{ ns} < t_{pulse} < 10 \mu\text{s}$

➤ **Active transformer:** Current sink by I/U-converter, $\tau_{droop} \approx 1$ s for long pulses

Application: macro-pulses at LINACs : $100 \mu\text{s} < t_{pulse} < 10 \text{ ms}$

General:

- The beam pipe has to be intersected to prevent the flow of the image current through the torus
- The torus is made of $25 \mu\text{m}$ isolated flat ribbon spiraled to get a torus of $\approx 15 \text{ mm}$ thickness, to have large electrical resistivity
- Additional winding for calibration with current source

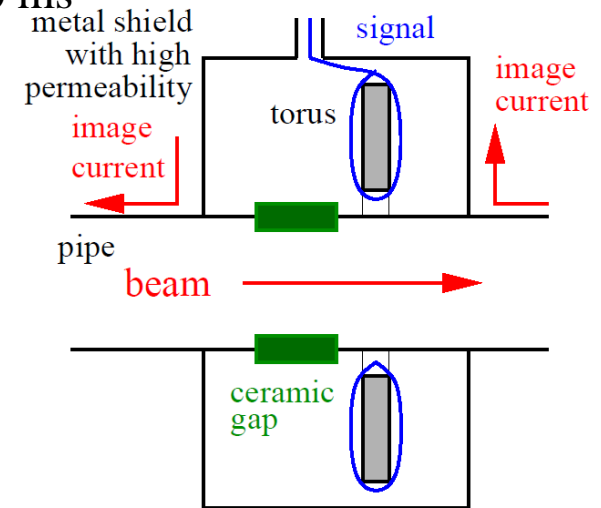

The Artist' View of Transformers



The active transformer ACCT



The passive, fast transformer FCT

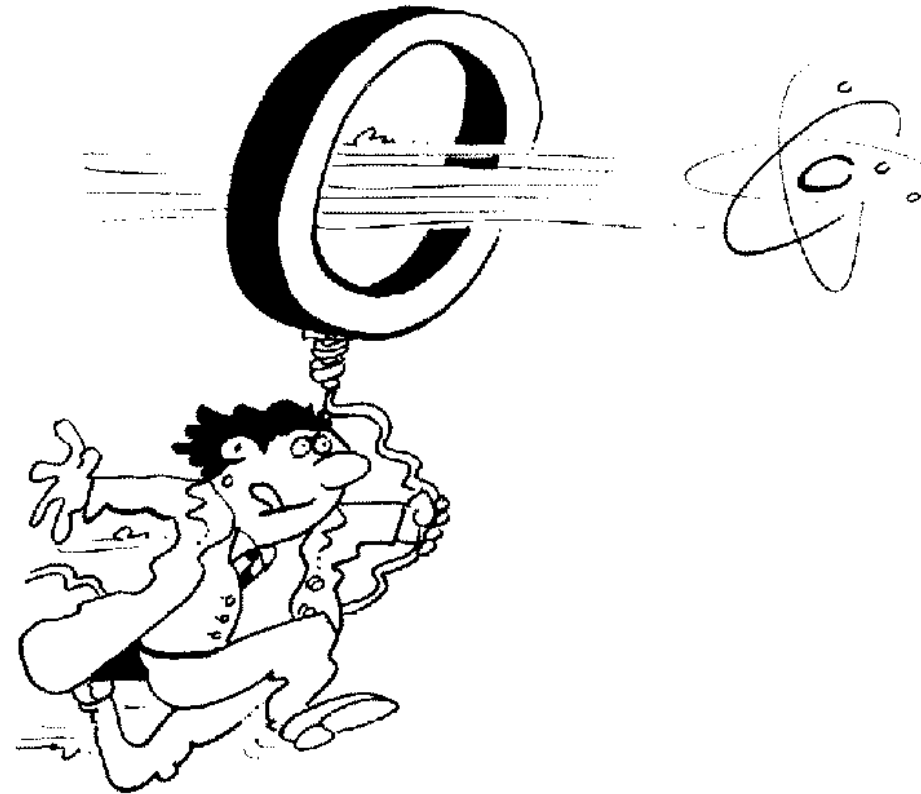

Cartoons by Company Bergoz, Saint Genis

The dc Transformer



How to measure the DC current? The current transformer discussed sees only B-flux *changes*. The DC Current Transformer (DCCT) → look at the magnetic saturation of two torii.

- **Modulation** of the primary windings forces both torii into saturation twice per cycle
- **Sense windings** measure the modulation signal and cancel each other.
- But with the I_{beam} , the saturation is shifted and I_{sense} is not zero
- **Compensation current** adjustable until I_{sense} is zero once again

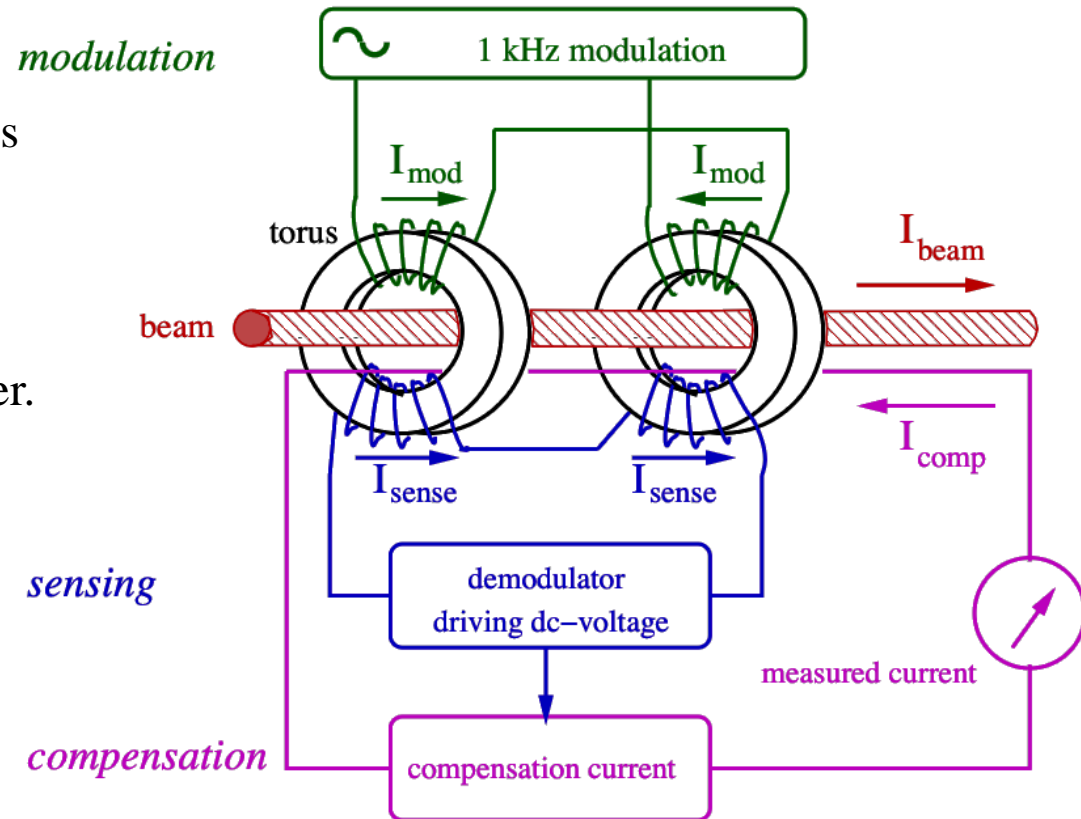

The dc Transformer

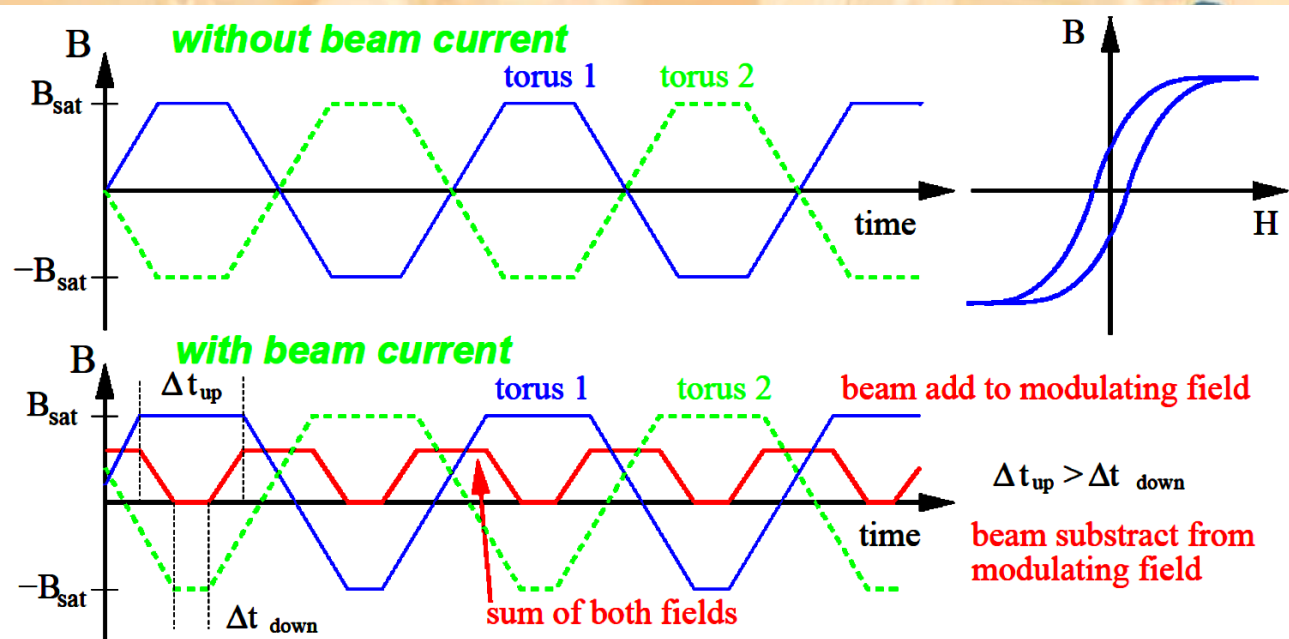

➤ **Modulation without beam:**

typically about 1 kHz to saturation → **no net flux**

➤ **Modulation with beam:**

saturation is reached at different times, → net flux

➤ **Net flux:** double frequency than modulation

➤ **Feedback:** Current fed to compensation winding for larger sensitivity

➤ **Two magnetic cores:** Must be very similar.

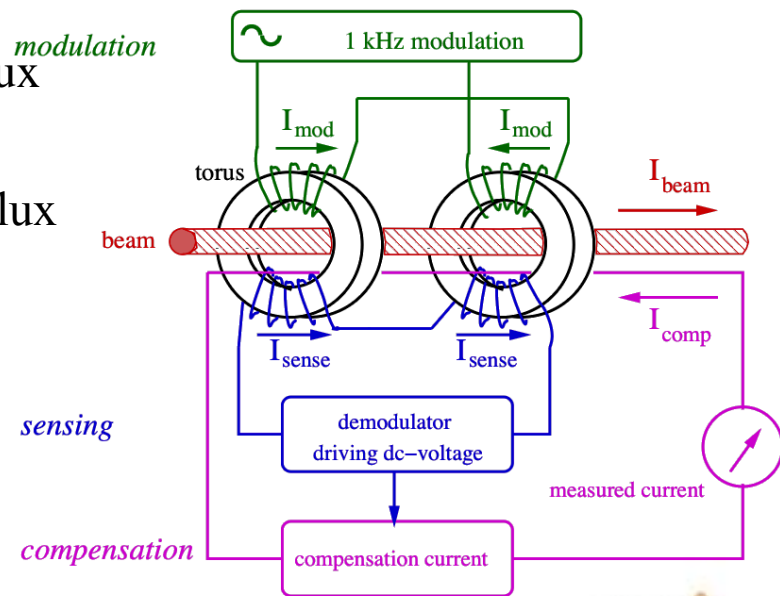

The dc Transformer Realization



Example: The DCCT at GSI synchrotron (designed 1990 at GSI):

Core radii	$r_i = 135 \text{ mm}, r_o = 145 \text{ mm}$
Core thickness	10 mm
Core material	Vitrovac 6025: $(\text{CoFe})_{70\%}(\text{MoSiB})_{30\%}$
Core permeability	$\mu_r \simeq 10^5$
Saturation B_{sat}	$\simeq 0.6 \text{ T}$
Isolating cap	Al_2O_3
Number of windings	16 for modulation and sensing 12 for feedback
Ranges for beam current	300 μA to 1 A
Resolution	2 μA
Bandwidth	dc to 20 kHz
rise time	20 μs
Offset compensation	$\pm 2.5 \mu\text{A}$ in auto mode < 15 $\mu\text{A}/\text{day}$ in free run
temperature coeff.	1.5 $\mu\text{A}/^\circ\text{C}$

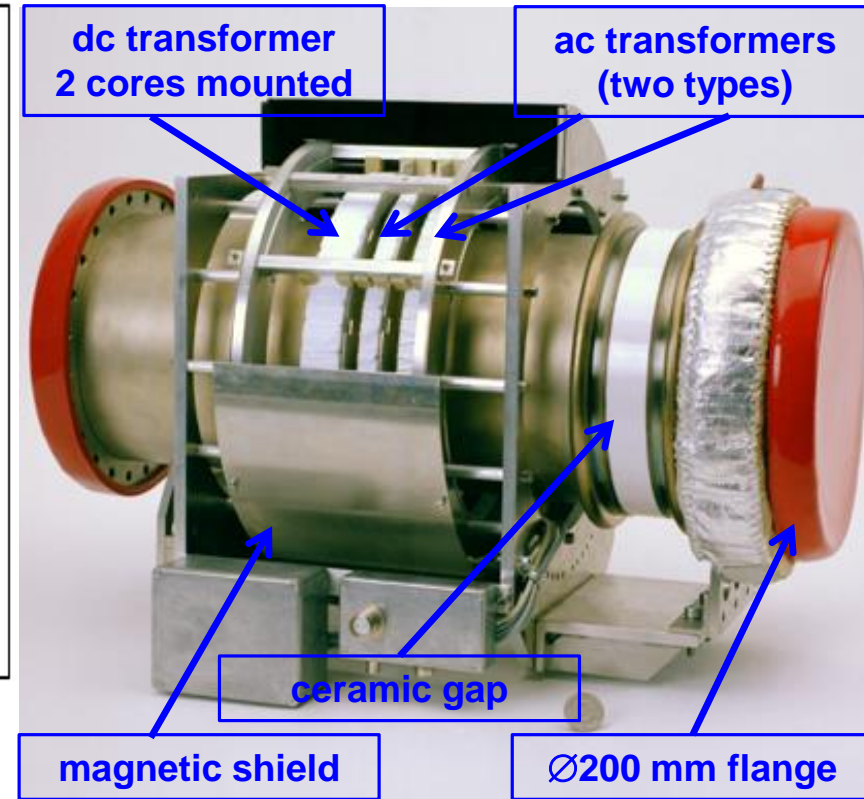

Recent commercial product specification (Bergoz NPCT):

Most parameters are comparable the GSI-model

Temperature coeff.	0.5 $\mu\text{A}/^\circ\text{C}$
Resolution	$\approx 10 \mu\text{A}$ (i.e. not optimized)

Measurement with a dc Transformer



Example: The DCCT at GSI synchrotron:

⇒ Observation of beam behavior with 20 μs time resolution → important operation tool.

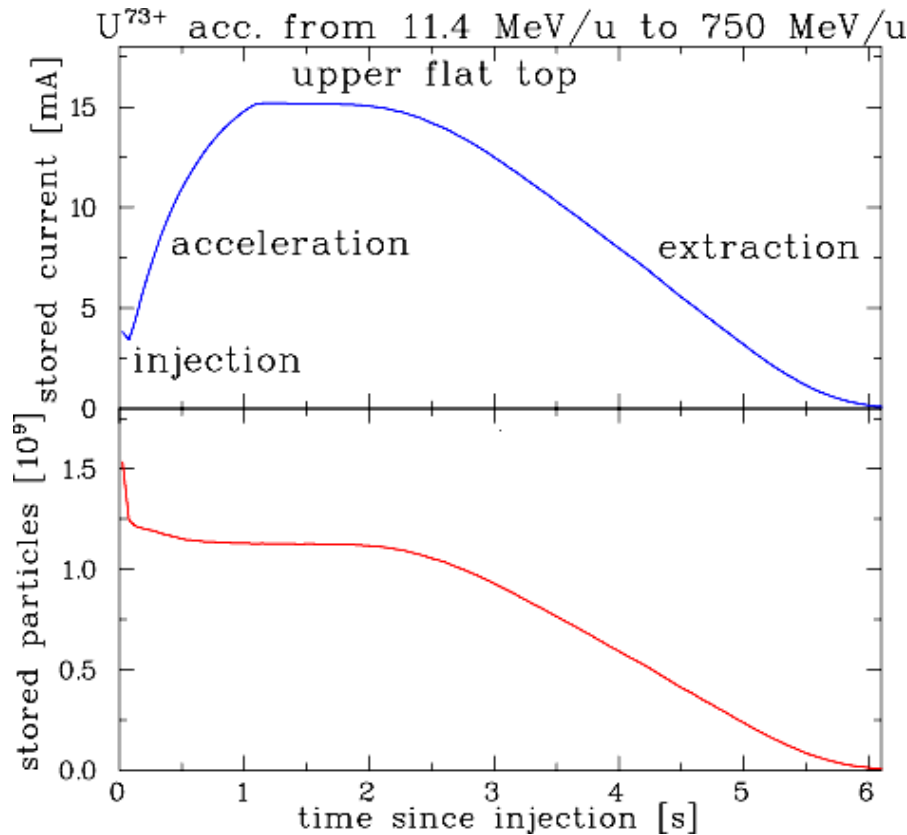

Important parameter:

Detection threshold: 1 μA

(= resolution)

Bandwidth: dc to 20 kHz

Rise-time: 20 μs

Temperature drift: 1.5 $\mu\text{A}/^\circ\text{C}$

⇒ compensation required.

Design Criteria and Limitations for a dc Transformer



Careful shielding against external fields with μ -metal.

- High resistivity of the core material to prevent for eddy current
⇒ thin, insulated strips of alloy.
- Barkhausen noise due to changes of Weiss domains
⇒ unavoidable limit for **DCCT**.
- Core material with low changes of μ_r due to temperature and stress
⇒ low micro-phonic pick-up.
- Thermal noise voltage $U_{eff} = (4kBT \cdot R \cdot f)^{1/2}$
⇒ only required bandwidth f , low input resistor R .
- Preventing for flow of secondary electrons through the core
⇒ need for well controlled beam centering close to the transformer.
⇒ **The current limits are: $\approx 1 \mu\text{A}$ for DCCT**

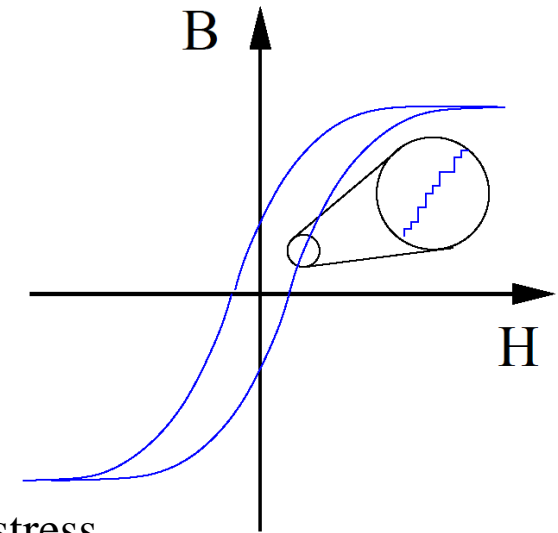

- $\approx 30 \mu\text{A}$ for FCT with 500 MHz bandwidth**
- $\approx 0.3 \mu\text{A}$ for ACT with 1 MHz bandwidth.**

The Artist' View of Transformers



The active transformer ACCT



The passive, fast transformer FCT

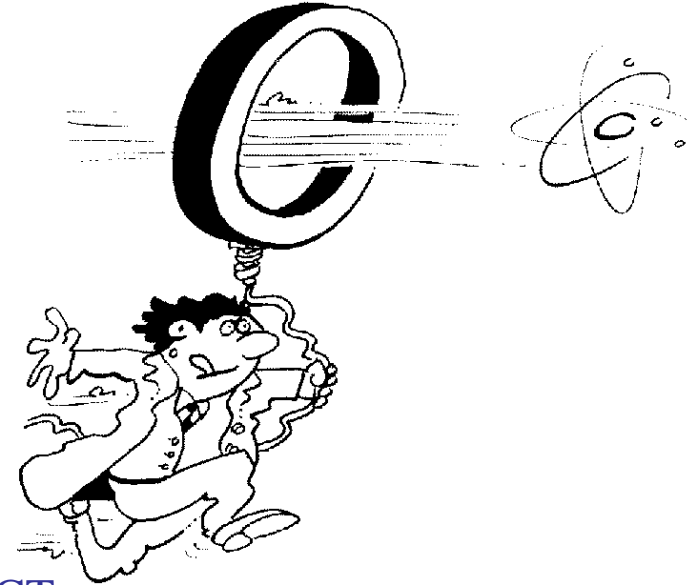

The dc transformer DCCT

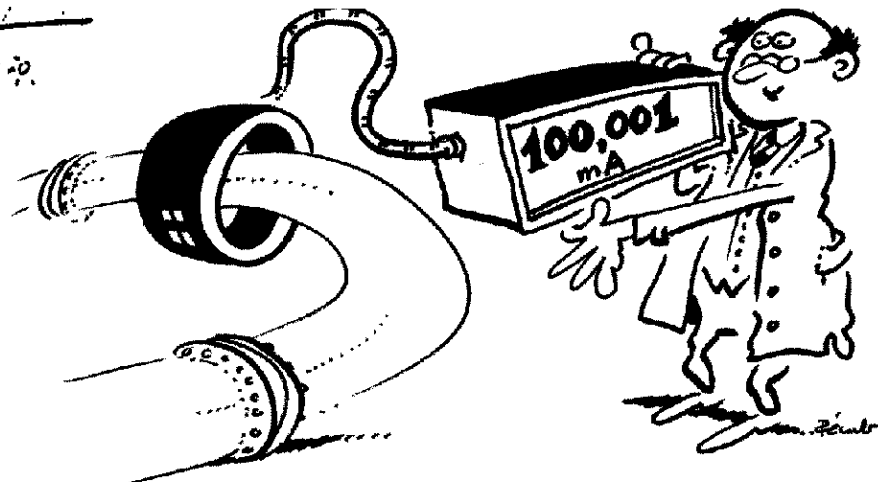

Company Bergoz



The beam current is the basic quantity of the beam.

- It is the first check of the accelerator functionality
- It has to be determined in an absolute manner
- Important for transmission measurement and to prevent beam losses.

Different devices are used:

- **Transformers:** Measurement of the beam's **magnetic field**

They are non-destructive. No dependence on beam energy

They have lower detection threshold.

- **Faraday cups:** Measurement of the beam's **electrical charges**

They are destructive. For low energies only

Low currents can be determined.

- **Particle detectors:** Measurement of the particle's **energy loss** in matter

Examples are scintillators, ionization chambers, secondary e⁻ emission monitors

Used for low currents at high energies e.g. for slow extraction from a synchrotron.

Excuse: Energy Loss of Ions in Copper



Bethe Bloch formula: (simplest formulation)

$$-\frac{dE}{dx} = 4\pi N_A r_e m_e c^2 \cdot \frac{Z_t}{A_t} \rho_t \cdot \frac{Z_p^2}{\beta^2} \left(\ln \frac{2m_e c^2 \gamma^2 \beta^2}{I} - \beta^2 \right)$$

Semi-classical approach:

➤ Projectiles of mass M collide with free electrons of mass m

➤ If $M \gg m$ then the relative energy transfer is low

⇒ many collisions required many electrons participate

proportional to electron density $n_e = \frac{Z_t}{A_t} \rho_t$

⇒ low straggling for the heavy projectile i.e. ‘straight trajectory’

➤ If projectile velocity $\beta \approx 1$ low relative energy change

I is mean ionization potential including kinematic corrections $I \approx 10$ eV for most metals

➤ Strong dependence on projectile charge Z_p

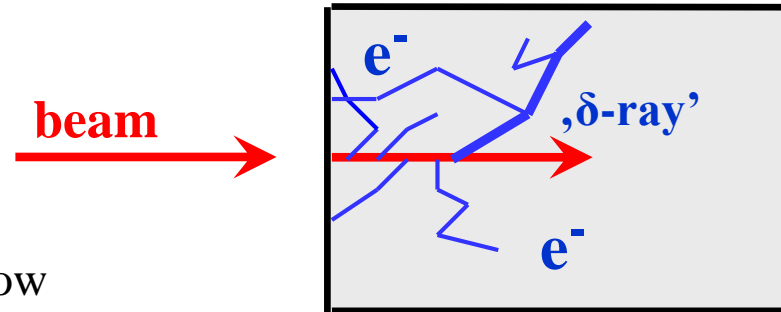

Energy Loss of Ions in Copper



Bethe Bloch formula:
$$-\frac{dE}{dx} = 4\pi N_A r_e m_e c^2 \cdot \frac{Z_t}{A_t} \rho_t \cdot \frac{Z_p^2}{\beta^2} \left(\ln \frac{2m_e c^2 \gamma^2 \beta^2}{I} - \beta^2 \right)$$

Range:
$$R = \int_0^{E_{\max}} \left(\frac{dE}{dx} \right)^{-1} dE$$

with approx. scaling $R \propto E_{\max}^{1.75}$

Numerical calculation

with semi-empirical model e.g. SRIM

Main modification $Z_p \rightarrow Z_p^{\text{eff}}(E_{\text{kin}})$

⇒ Cups only for

$E_{\text{kin}} < 100 \text{ MeV/u}$ due to $R < 10 \text{ mm}$

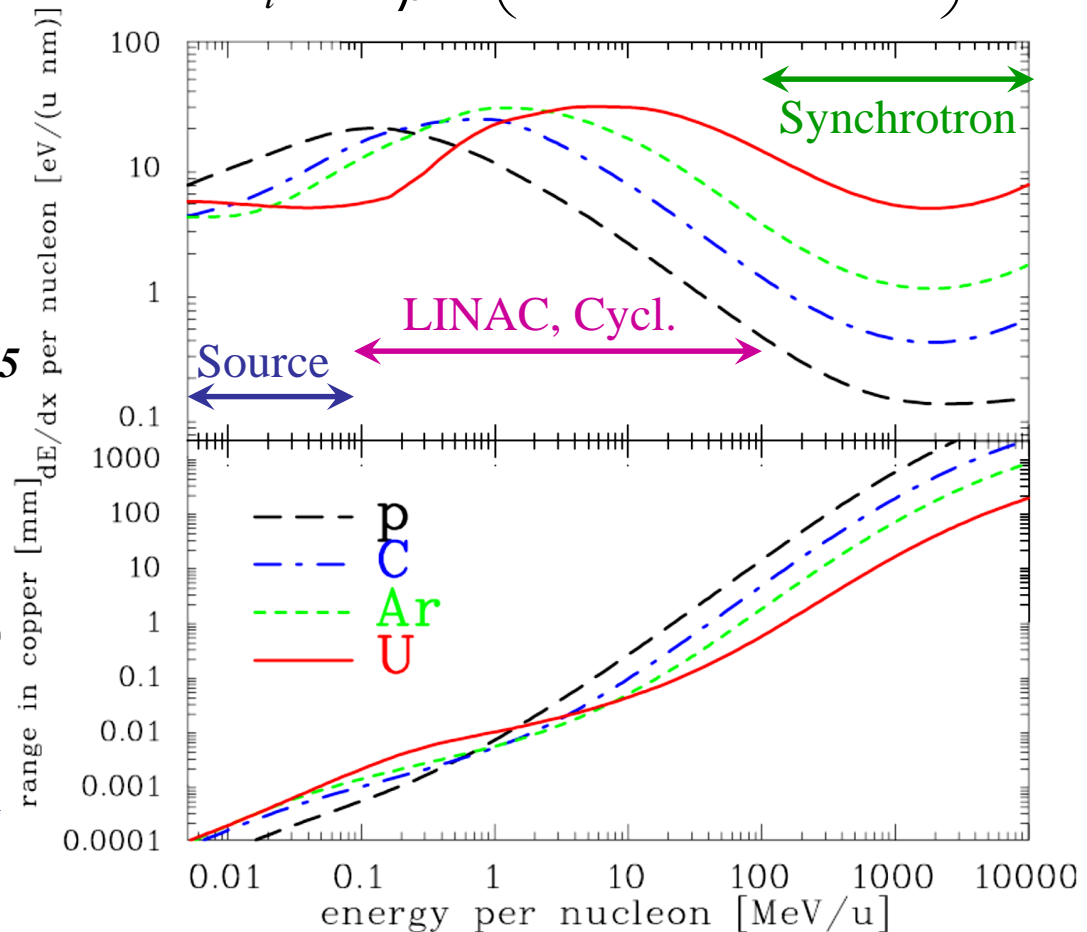

Excuse: Secondary Electron Emission by Ion Impact



Energy loss of ions in metals close to a surface:

Distant collisions → slow e^- with $E_{kin} \leq 10$ eV

→ ‘diffusion’ & scattering with other e^- : scattering length $L_s \approx 1 - 10$ nm

→ at surface ≈ 90 % probability for escape

Closed collision: → fast e^- with $E_{kin} \gg 100$ eV inelastic collision and ‘thermalization’

Secondary **electron yield** and energy distribution comparable for all metals!

$$\Rightarrow Y = const. * dE/dx \quad (\text{Sternglass formula})$$

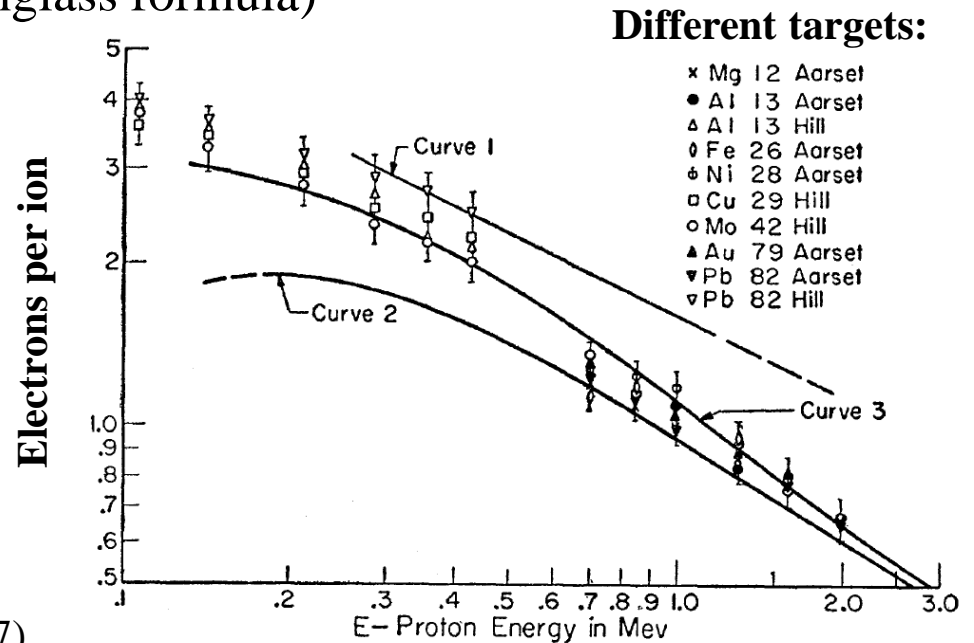
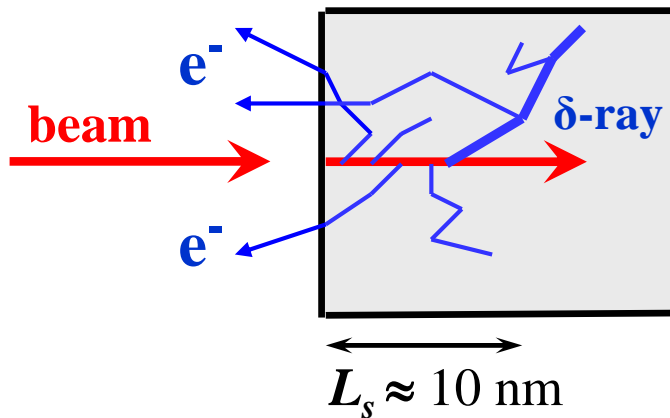

From E.J. Sternglass, Phys. Rev. 108, 1 (1957)

Excuse: Secondary Electron Emission by Ion Impact



Energy loss of ions in metals close to a surface:

Distant collisions \rightarrow slow e^- with $E_{kin} \leq 10$ eV

\rightarrow 'diffusion' & scattering with other e^- : scattering length $L_s \approx 1 - 10$ nm

\rightarrow at surface $\approx 90\%$ probability for escape

Closed collision: \rightarrow fast e^- with $E_{kin} \gg 100$ eV inelastic collision and 'thermalization'

Secondary **electron yield** and energy distribution comparable for all metals!

$$\Rightarrow Y = const. * dE/dx \quad (\text{Sternglass formula})$$

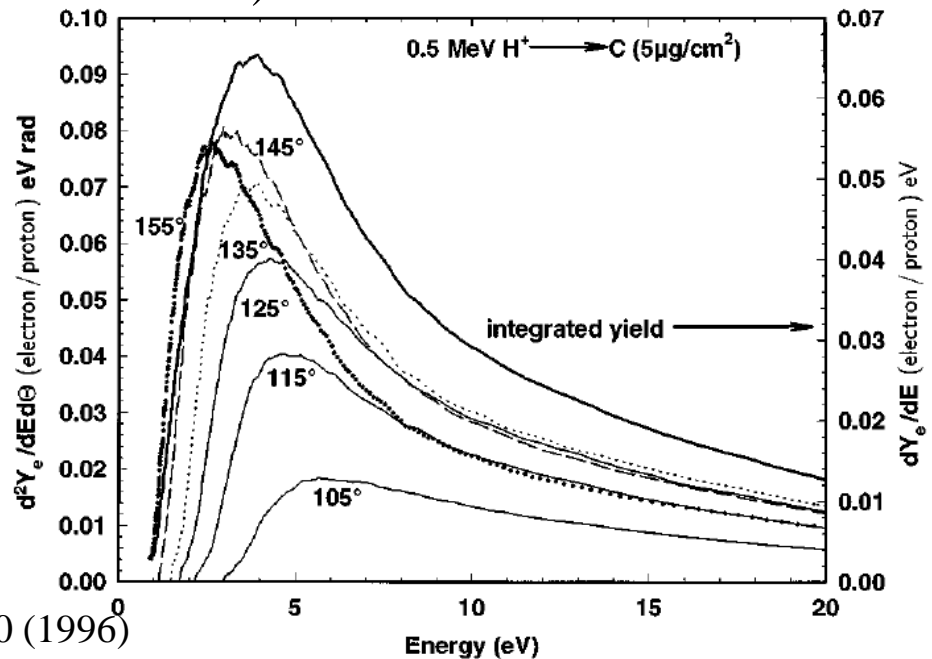
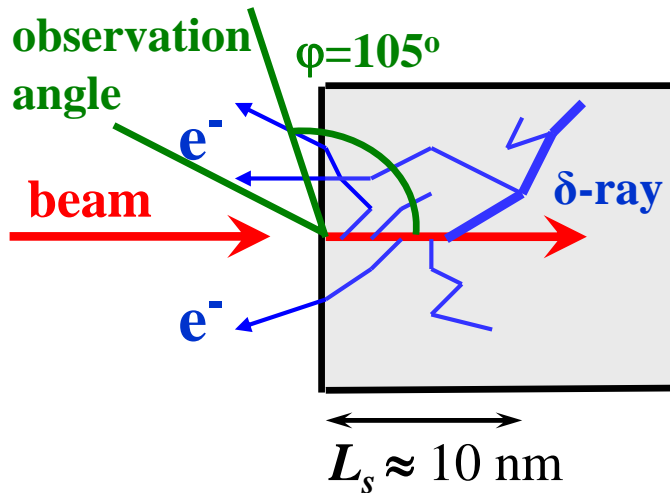

From C.G. Drexler, R.D. DuBois, Phys. Rev. A 53, 1630 (1996)

Faraday Cups for Beam Charge Measurement



The beam particles are collected inside a metal cup
⇒ The beam's charge are recorded as a function of time.

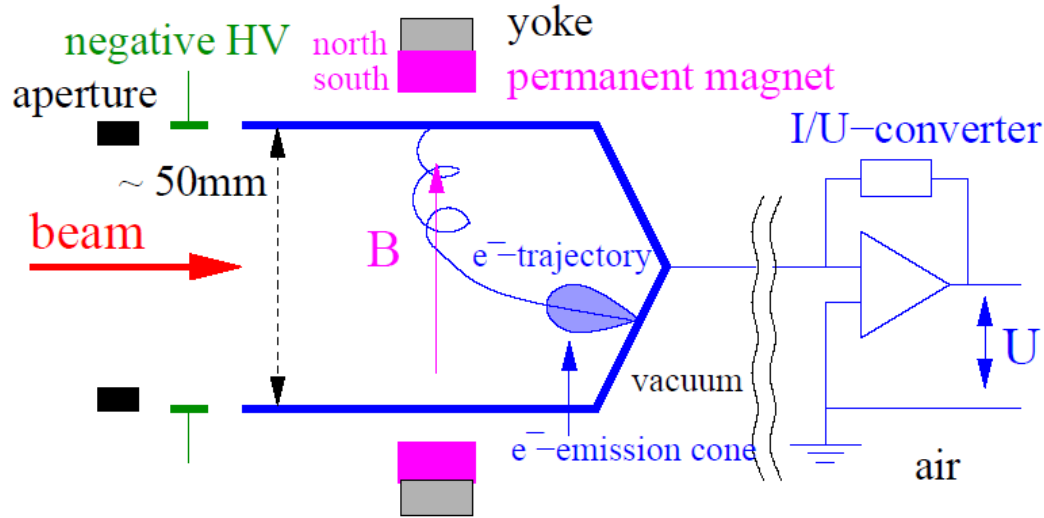

The cup is moved in the beam pass → destructive device

Currents down to 10 pA with bandwidth of 100 Hz!

Magnetic field:

To prevent for secondary electrons leaving the cup
and/or

Electric field:

Potential barrier at the cup entrance.



Realization of a Faraday Cup at GSI LINAC



The Cup is moved into the beam pass.

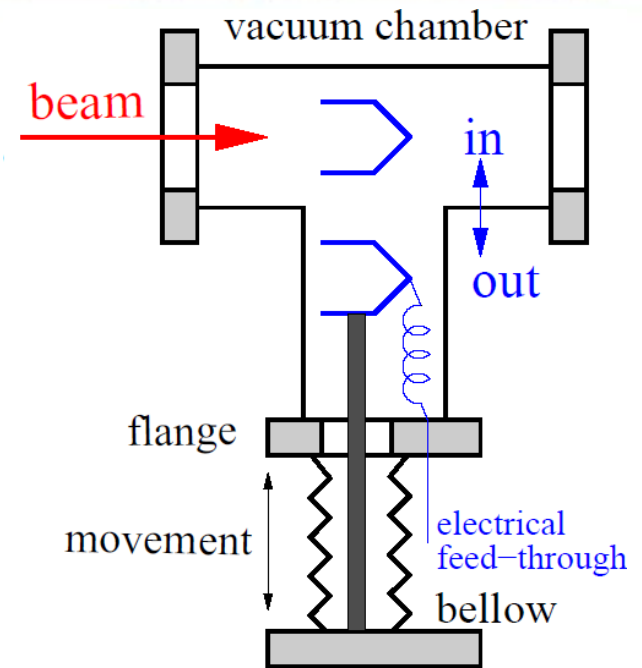
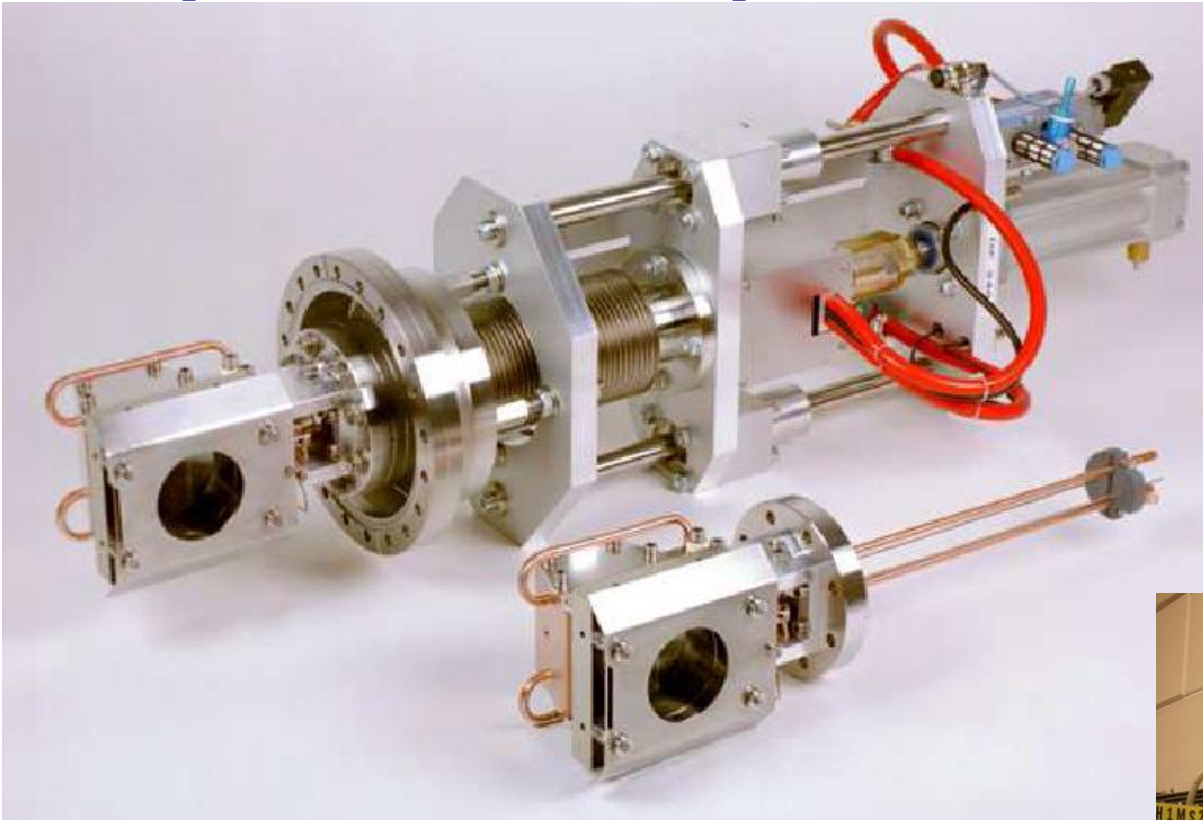

Secondary Electron Suppression: Electric Field

A ring shaped electrode is used at the entrance of Faraday Cup:
 Typical voltage 100 to 1000 V

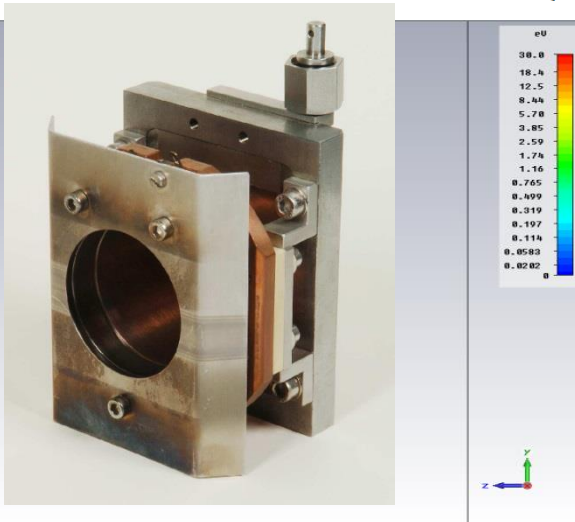
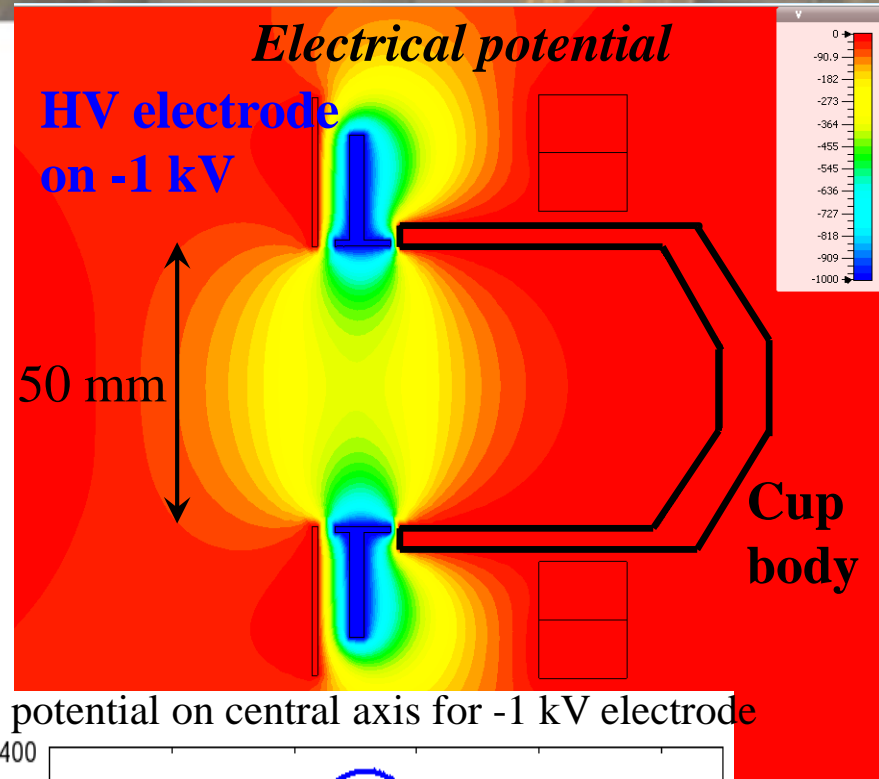
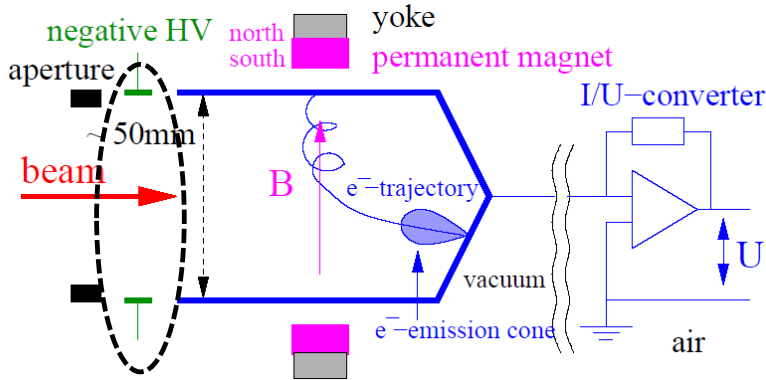

potential on central axis for -1 kV electrode

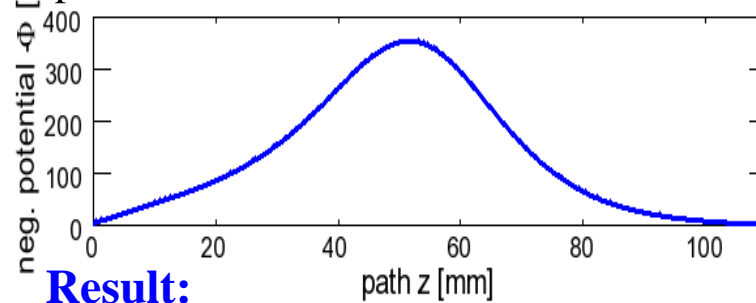

Result:

here: potential at center $\approx 30\%$ of applied voltage

Courtesy of J. Latzko, GSI

Secondary Electron Suppression: Magnetic Field

Co-Sm permanent magnets within the yoke and the calculated magnetic field lines. The central field strength is $B \approx 0.1$ T.

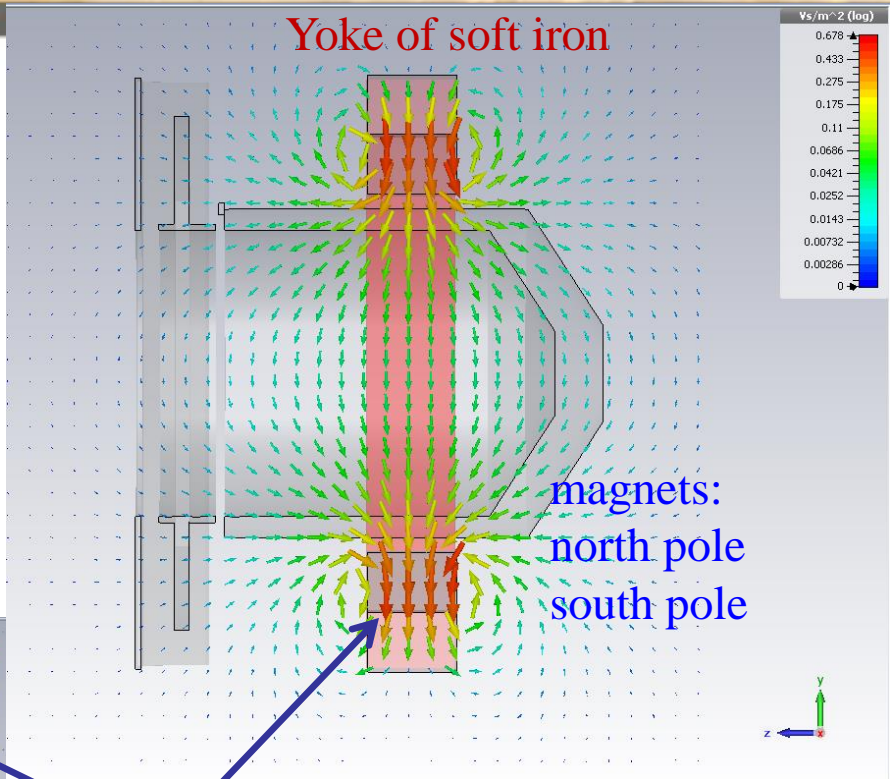
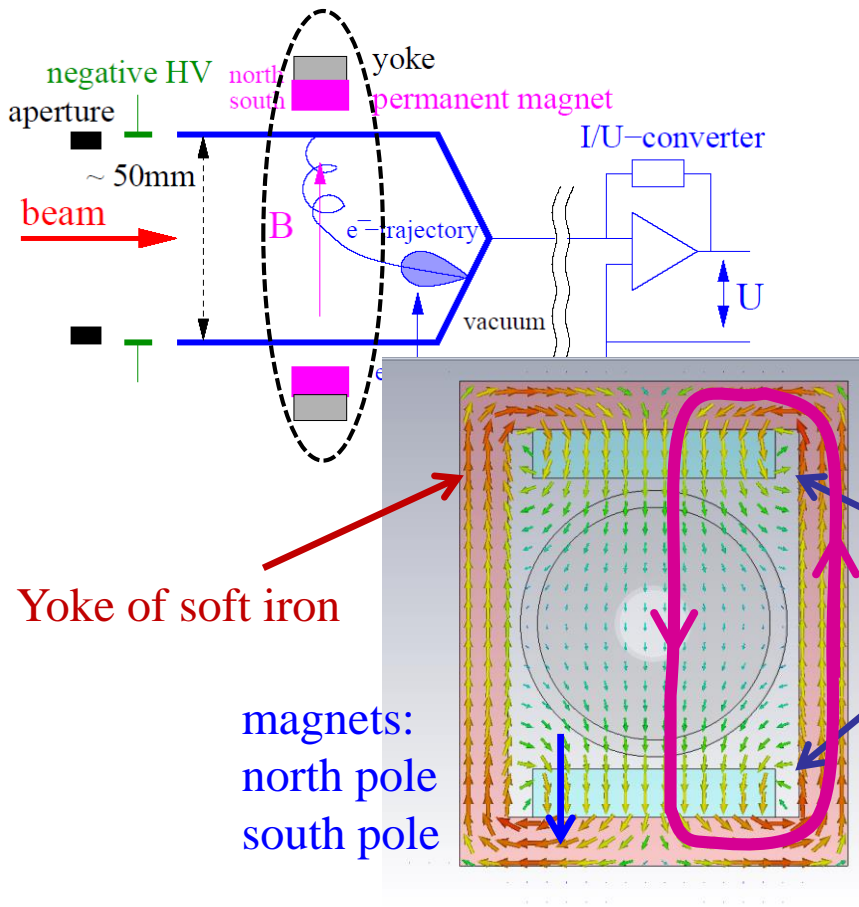

Yoke of soft iron

magnets:
 north pole
 south pole

B permanent magnets

Courtesy of J. Latzko, GSI

Energy Loss of Ions in Copper



Bethe Bloch formula:
$$-\frac{dE}{dx} = 4\pi N_A r_e m_e c^2 \cdot \frac{Z_t}{A_t} \rho_t \cdot \frac{Z_p^2}{\beta^2} \left(\ln \frac{2m_e c^2 \gamma^2 \beta^2}{I} - \beta^2 \right)$$

Range:
$$R = \int_0^{E_{\max}} \left(\frac{dE}{dx} \right)^{-1} dE$$

with approx. scaling $R \propto E_{\max}^{1.75}$

Numerical calculation

with semi-empirical model e.g. SRIM

Main modification $Z_p \rightarrow Z_p^{\text{eff}}(E_{\text{kin}})$

⇒ Cups only for

$E_{\text{kin}} < 100 \text{ MeV/u}$ due to $R < 10 \text{ mm}$

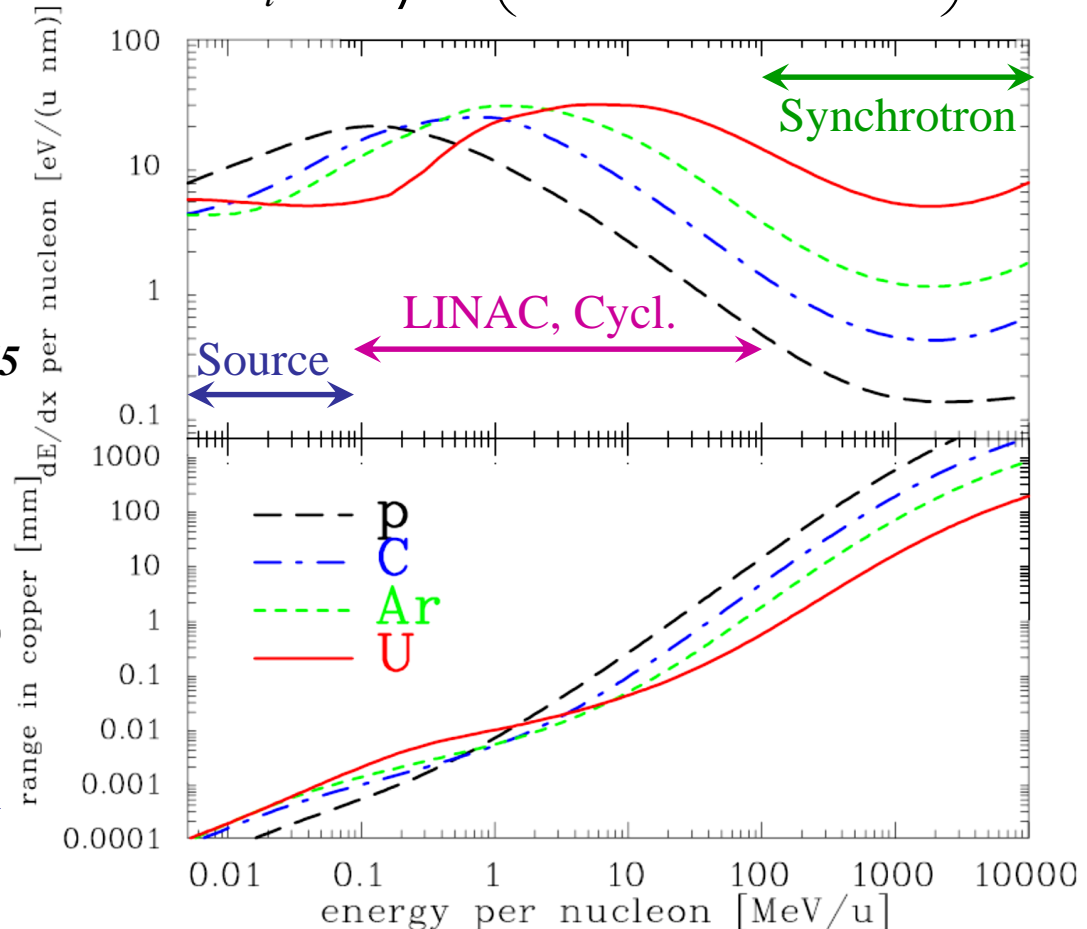

Faraday Cups for high Intensity Ion Beam → Surface Heating



The heating of material has to be considered, given by the energy loss.

The cooling is done by radiation due to Stefan-Boltzmann: $P_r = \epsilon \sigma T^4$

Example: Beam current: 11.4 MeV/u Ar¹⁰⁺ with 10 mA and 1 ms beam delivery

Beam size: 5 mm FWHM → 23 kW/mm², $P_{peak} = 450$ kW total power during 1ms delivery

Foil: 1 μm Tantalum, emissivity $\epsilon = 0.49$

Temperature increase:

T > 2000 °C during beam delivery

Even for low average power,
the material should
survive the peak power!

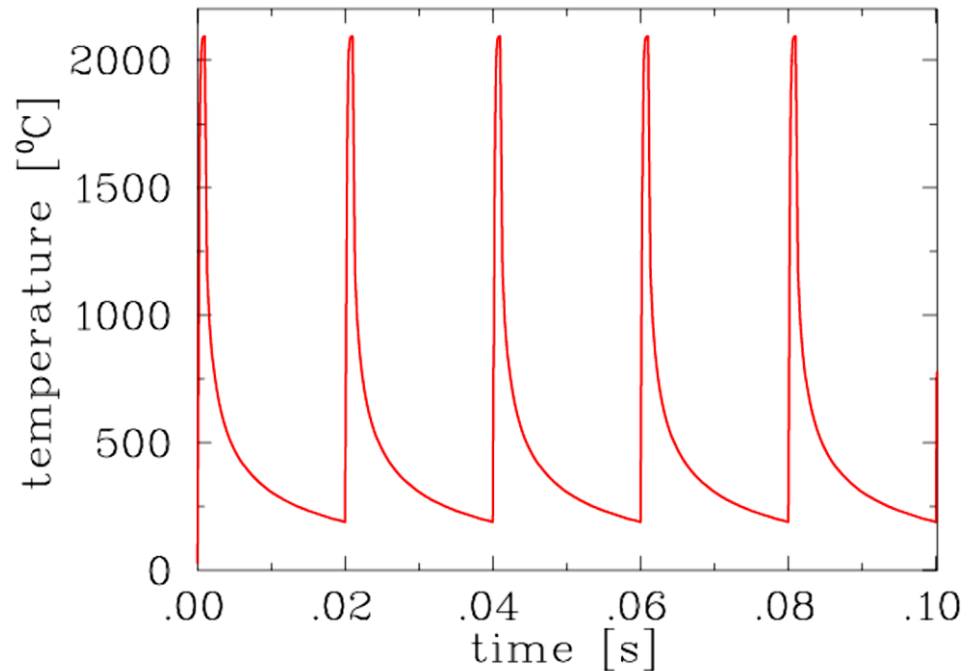

High Power Faraday Cups



Cups designed for 1 MW, 1 ms pulse power → cone of Tungsten-coated Copper

Bismuth for high melting temperature and copper for large head conductivity.

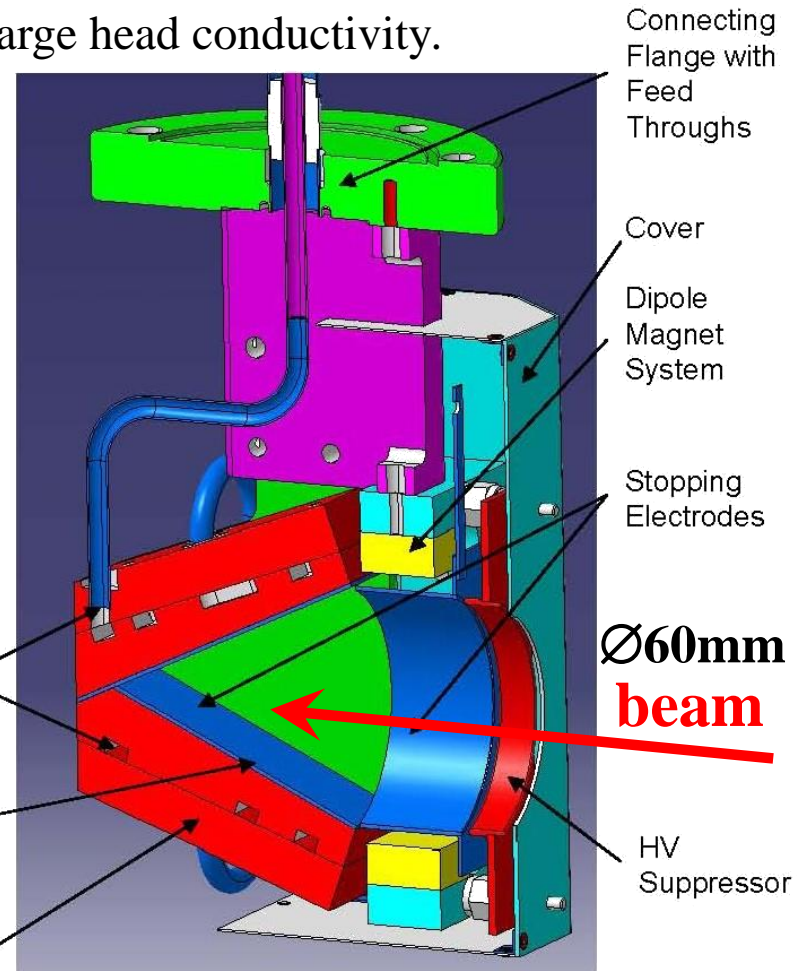
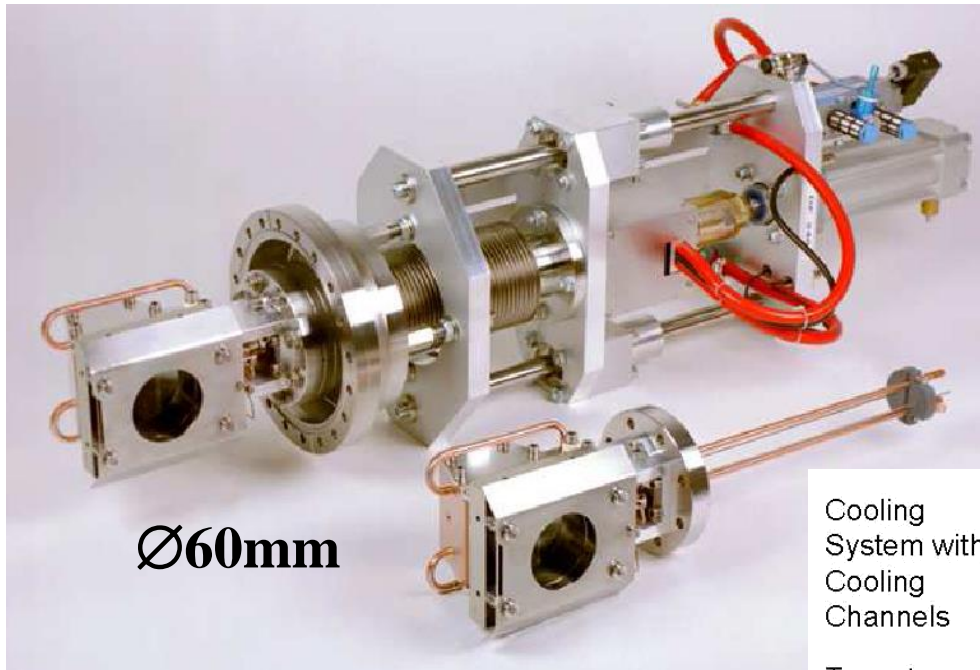

Energy Loss of Electrons in Copper & Faraday Cups of e^-



Bethe Bloch formula is valid for all charged particles.

However, Bremsstrahlung (i.e. γ -rays of some MeV) dominates for energies above 10 MeV.

e^- shows much larger longitudinal and transverse straggling

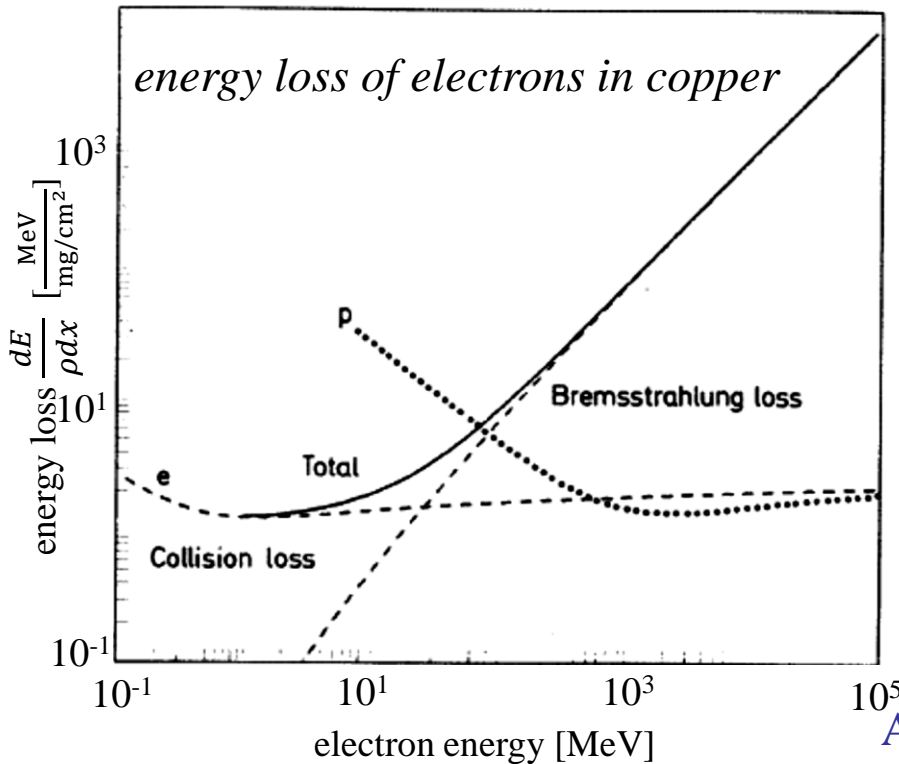

Example of a Faraday cup for 60 MeV Electrons

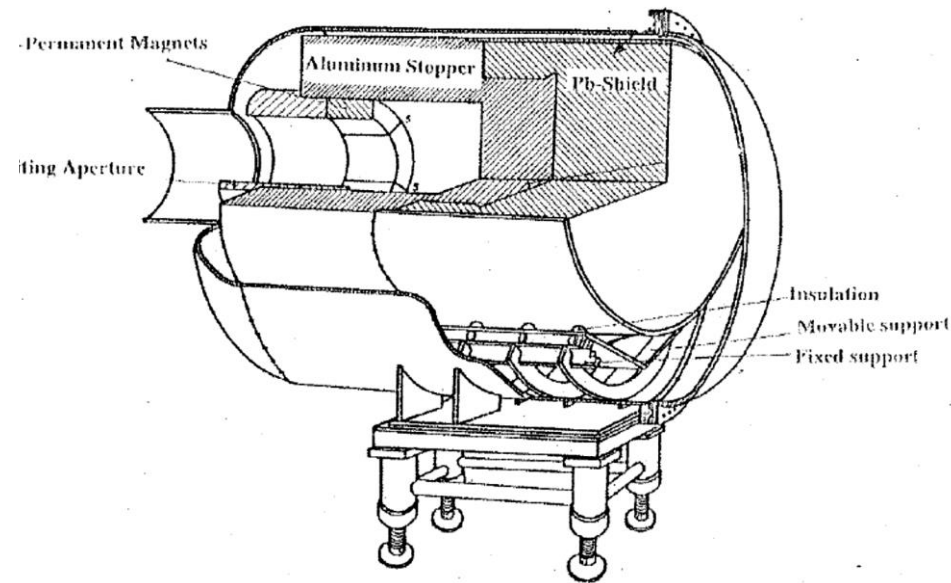

Al stopper: Stopping of e^- gently in low-Z material

Pb-shield: Absorption of Bremsstrahlungs- γ

\Rightarrow Used as beam dump

Energy Loss of Electrons in Copper & Faraday Cups of e^-



Bethe Bloch formula is valid for all charged particles.

However, Bremsstrahlung dominates for energies above 10 MeV.

e^- shows much larger longitudinal and transverse straggling

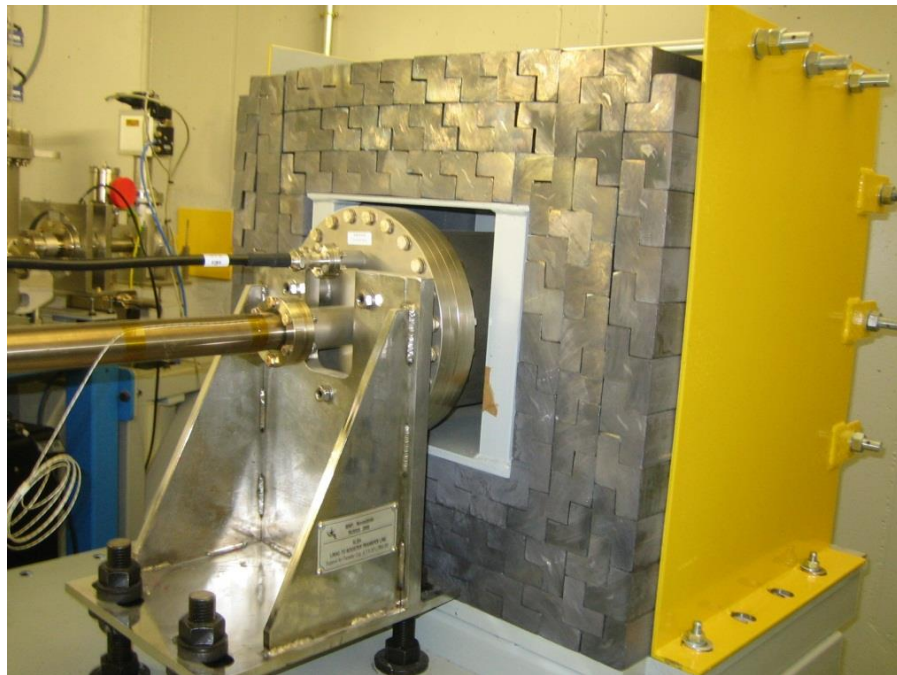

Faraday Cup at ALBA used as beam dump

From U. Iriso (ALBA)

Example of a Faraday cup for 60 MeV Electrons

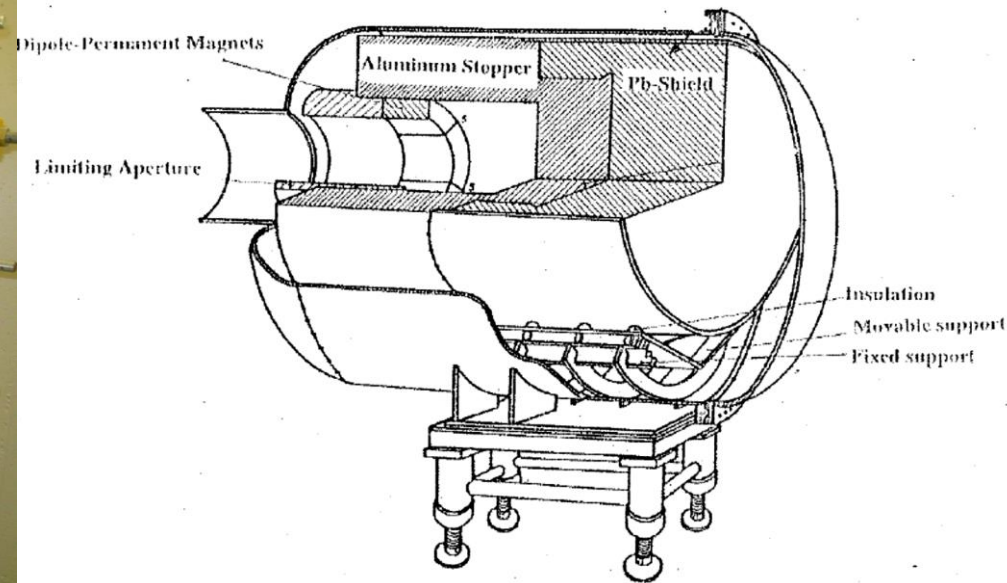

Al stopper: Stopping of e^- gently in low-Z material

Pb-shield: Absorption of Bremsstrahlungs- γ

\Rightarrow Used as beam dump



The beam current is the basic quantity of the beam.

- It is the first check of the accelerator functionality
- It has to be determined in an absolute manner
- Important for transmission measurement and to prevent beam losses.

Different devices are used:

- **Transformers:** Measurement of the beam's **magnetic field**

They are non-destructive. No dependence on beam energy

They have lower detection threshold.

- **Faraday cups:** Measurement of the beam's **electrical charges**

They are destructive. For low energies only

Low currents can be determined.

- **Particle detectors:** Measurement of the particle's **energy loss** in matter

Examples are scintillators, ionization chambers, secondary e⁻ emission monitors

Used for low currents at high energies e.g. for slow extraction from a synchrotron.

Low Current Measurement for slow Extraction



Slow extraction from synchrotron: lower current compared to LINAC, but higher energies and larger range $R \gg 1$ cm.

➤ **Particle counting:**

max: $r \approx 10^6$ 1/s

➤ **Energy loss in gas (IC):**

min: $I_{sec} \approx 1$ pA

max: $I_{sec} \approx 1$ μ A

➤ **Sec. e⁻ emission:**

min: $I_{sec} \approx 1$ pA

➤ **Max. synch. filling:**

Space Charge Limit (SCL).

Particle detector technologies for ions of 1 GeV/u, $A = 1$ cm²:

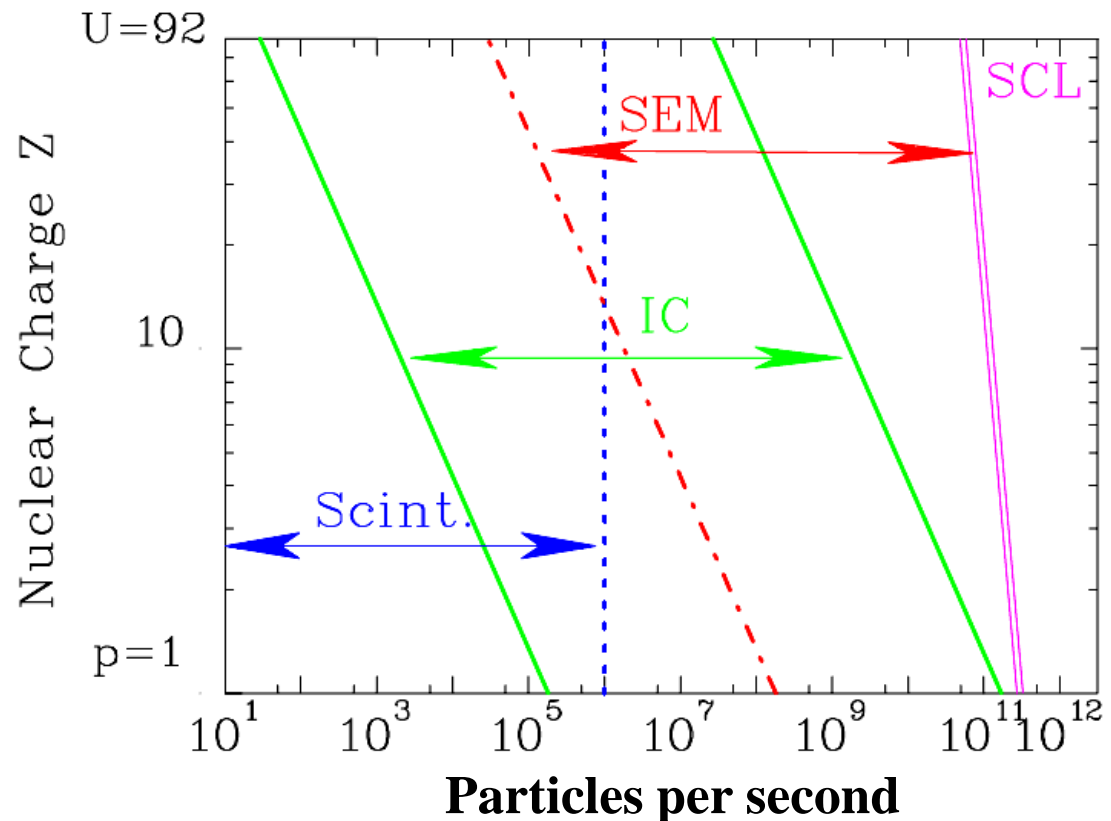

Example of Scintillator Counter



Example: Plastic Scintillator i.e. organic fluorescence molecules in a plastic matrix

Advantage: any mechanical form, cheap, blue wave length, fast decay time

Disadvantage: not radiation hard

Particle counting: PMT → discriminator → scalar → computer

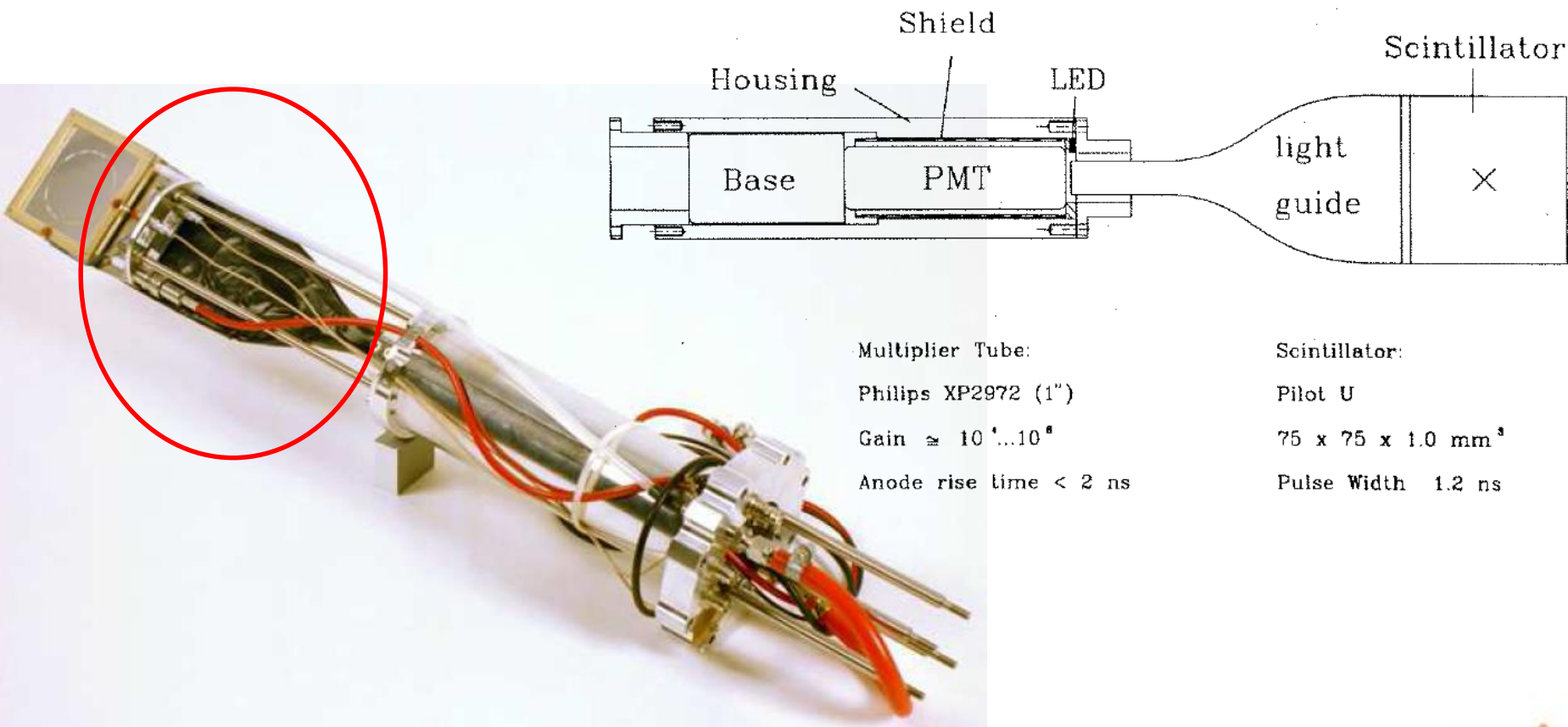

Low Current Measurement: Particle Detectors



Electronic solid state amplifier have finite noise contribution

Theoretical limit: $U_{eff} = \sqrt{4k_B \cdot R \cdot \Delta f \cdot T}$

Signal-to-Noise ratio limits the minimal detectable current

Idea: Amplification of single particles with photo-multiplier, sec. e⁻ multiplier or MCPs and particle counting typically up to $\approx 10^6$ 1/s

Scheme of a photo-multiplier:

➤ Photon hits photo cathode

➤ Secondary electrons are

acc. to next dynode $\Delta U \approx 100$ V

➤ Typ. 10 dynodes $\Rightarrow 10^6$ fold amplification

Advantage: no thermal noise
due to electro static acceleration
Typical 1 V signal output

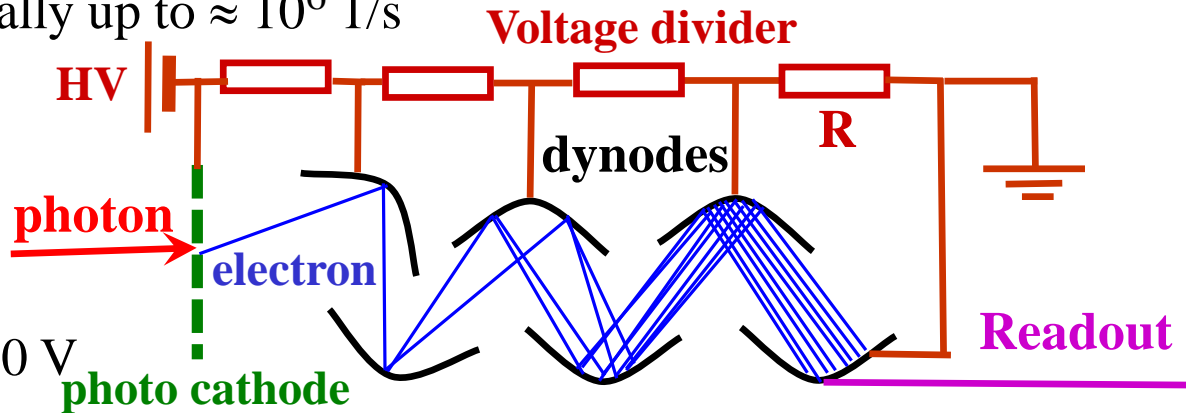

Properties of a good Scintillator



Properties of a good scintillator:

- Light output linear to energy loss
- Fast decay time → high rate
- No self-absorption
- Wave length of fluorescence
 $350 \text{ nm} < \lambda < 500 \text{ nm}$
- Index of refractivity $n \approx 1.5$
→ light-guide
- Radiation hardness
e.g. Ce-activated inorganic
are much more radiation hard.

Analog pulses from a plastic sc. with a low current 300 MeV/u Kr beam.

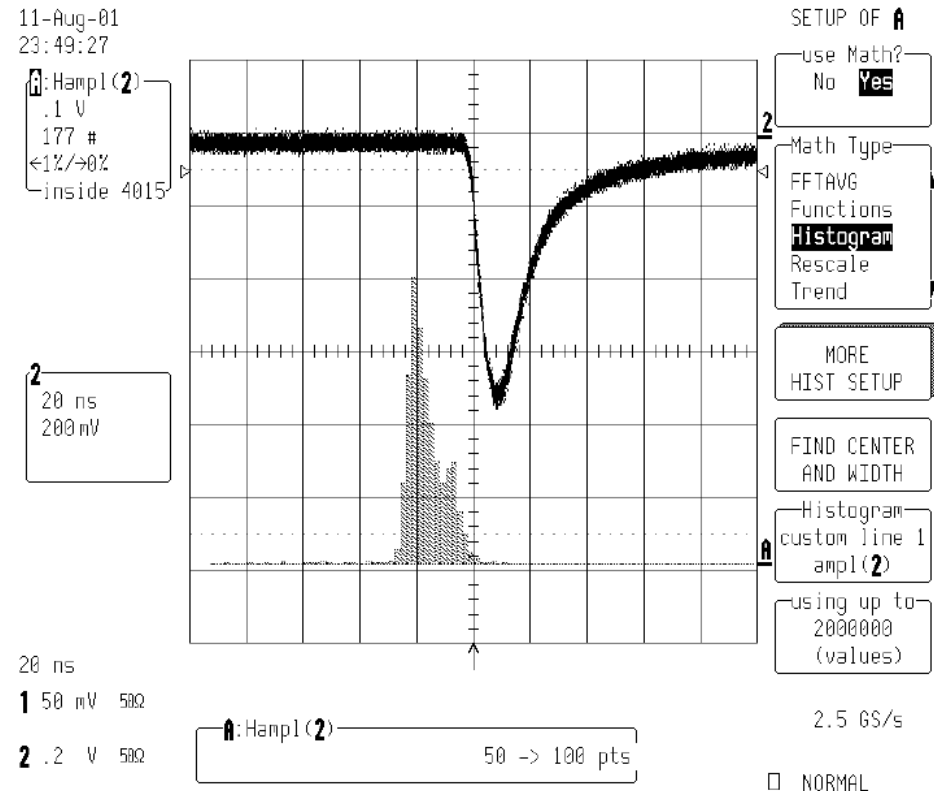

The scaling is 20 ns/div and 100 mV/div.

Monitoring of Slow Extraction



Slow extraction from a synchrotron delivers countable currents

Example: Comparison for different detector types:

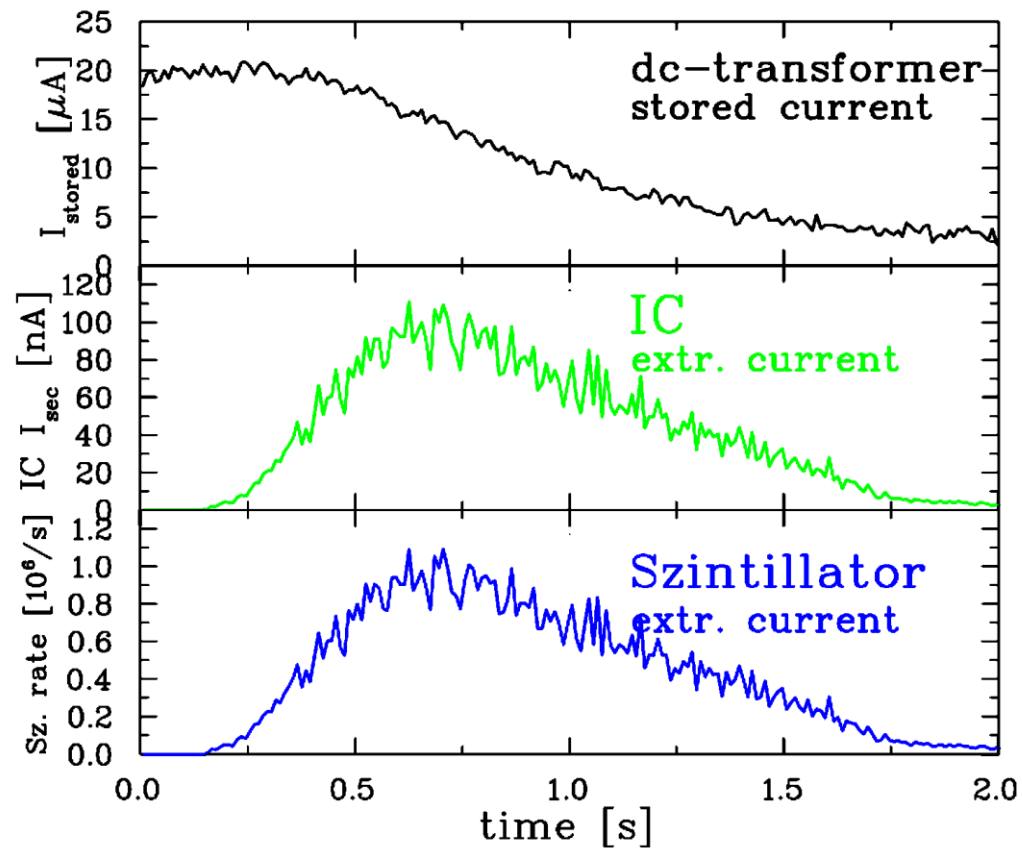

Parameters: dc-transformer inside the synch., ionization chamber and scintillator for a 250 MeV/u Pb^{67+} beam with a total amount of 10^6 particles.

Ionization Chamber (IC): Electron Ion Pairs

Energy loss of charged particles in gases → electron-ion pairs → low current meas.

$$I_{sec} = \frac{1}{W} \cdot \frac{dE}{dx} \Delta x \cdot I_{beam}$$

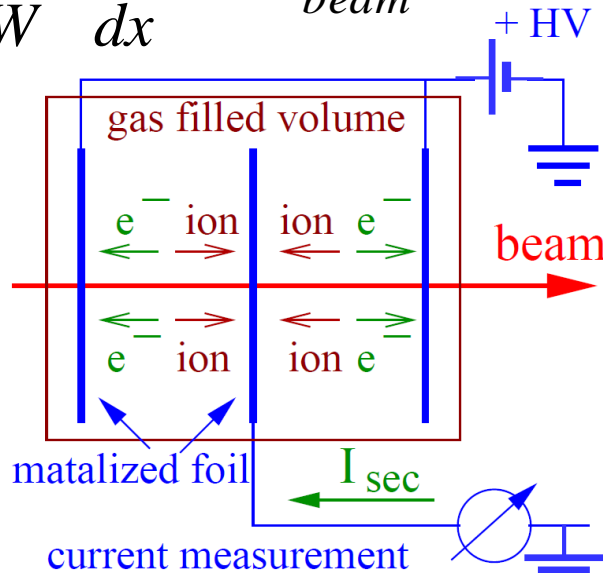

Example: GSI type

active surface	64 × 64 mm ²
active length Δx	5 mm
electrode material	1.5 μm Mylar
coating	100 μg/cm ² silver
gas (flowing)	80 % Ar + 20 %CO ₂
pressure	1 bar
voltage	500 ... 2000 V

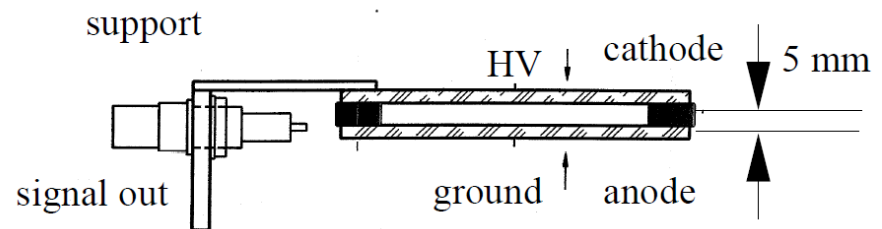
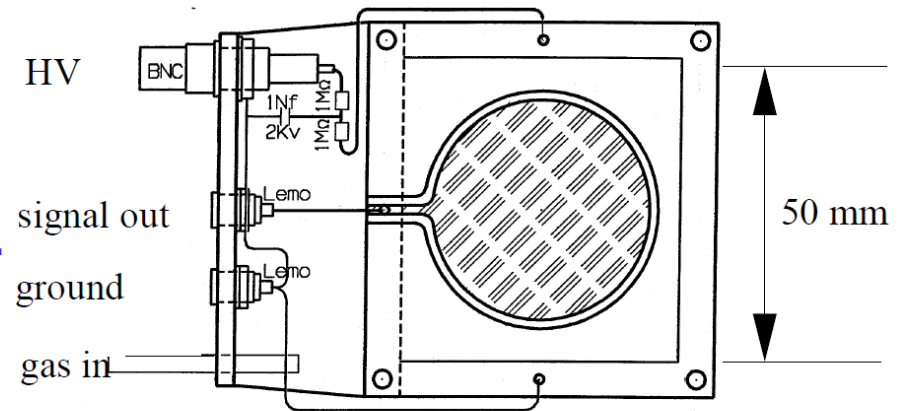

W is average energy for one e⁻ -ion pair:

Gas	ioni. pot. [eV]	W-value [eV]
He	24.5	42.7
O ₂	12.5	32.2
Ar	15.7	26.3
CH ₄	14.5	29.1
CO ₂	13.7	33.0

Secondary Electron Monitor (SEM): Electrons from Surface



For higher intensities SEMs are used.

Due to the energy loss, secondary e^- are emitted from a metal surface.

The amount of secondary e^- is proportional to the energy loss

$$I_{\text{sec}} = Y \cdot \frac{dE}{dx} \cdot I_{\text{beam}}$$

Example: GSI SEM type

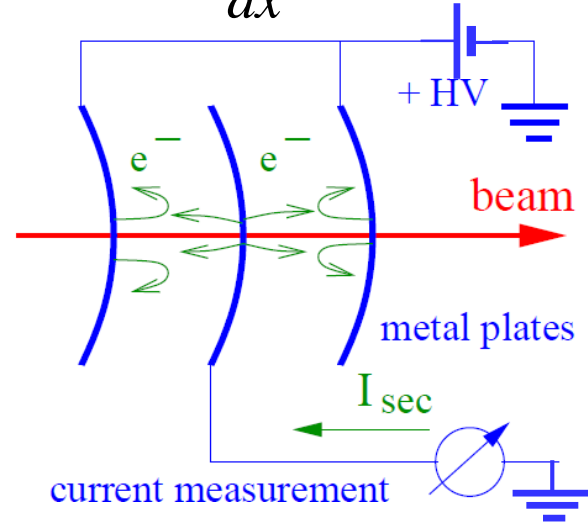

material	pure Al ($\simeq 99.5\%$)
# of electrodes	3
active surface	$80 \times 80 \text{ mm}^2$
distance	5 mm
voltage	100 V

Advantage for Al: good mechanical properties.

Disadvantage: Surface effect!

e.g. decrease of yield Y due to radiation

\Rightarrow Ti foils for a permanent insertion.

It is a *surface* effect:

\rightarrow Sensitive to cleaning procedure

\rightarrow Possible surface modification by radiation

Sometimes they are installed permanently in front of an experiment.

GSI Installation for SEM, IC and Scintillator



SEM in vacuum

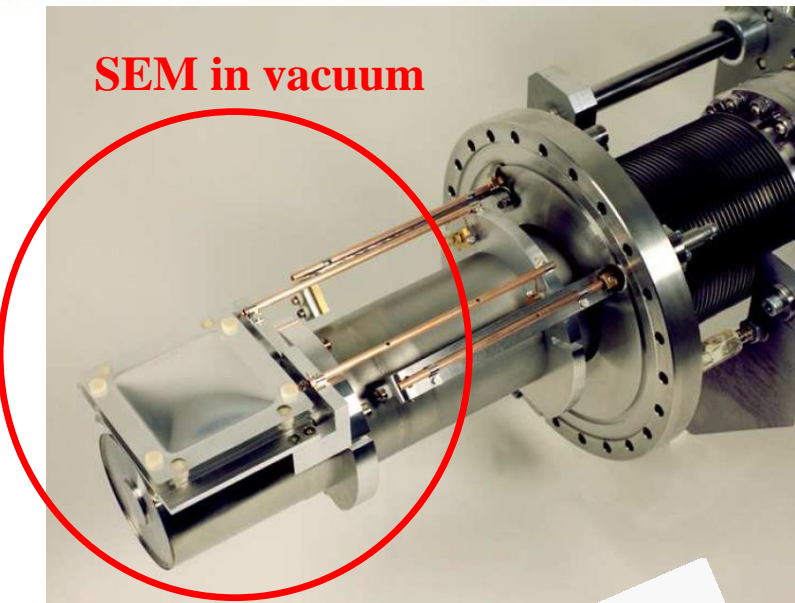

IC in Ar-gas at 1 bar

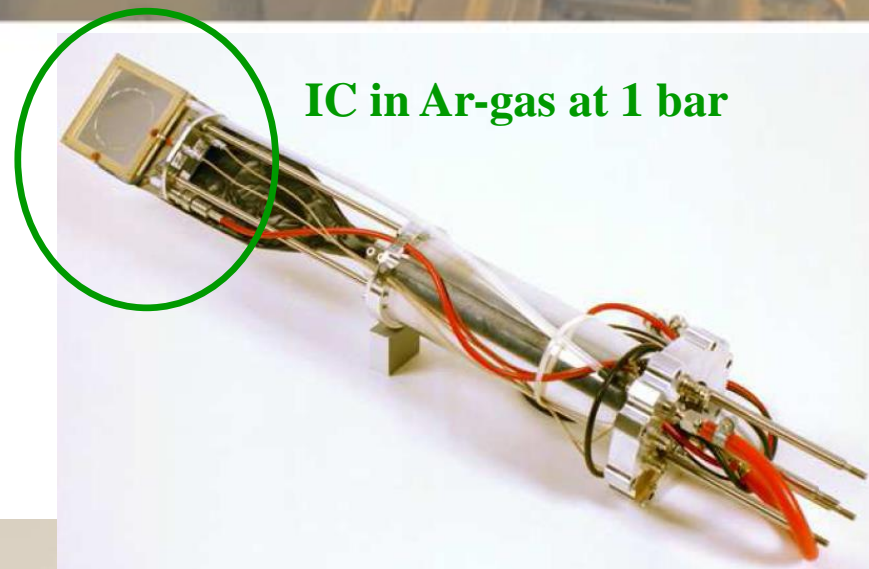

beam

SEM

gas filled

PMT

Scintillator

IC

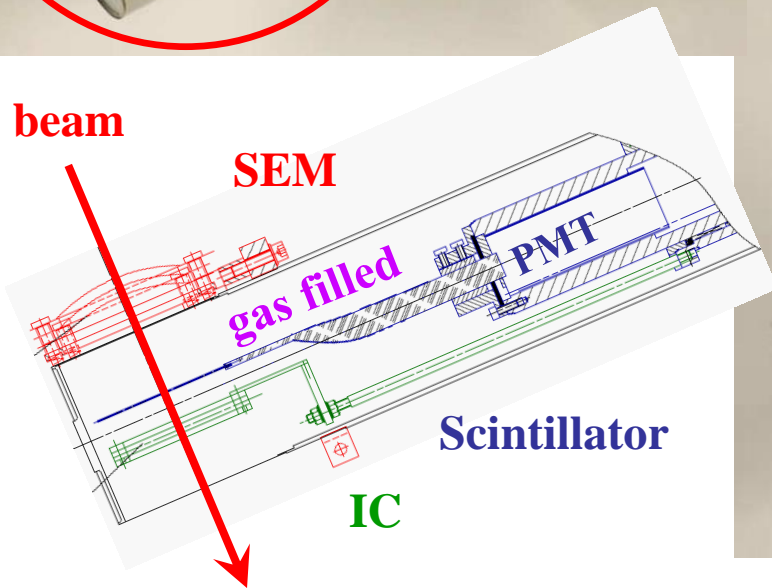

Feed-through with
Ø 200 mm flange

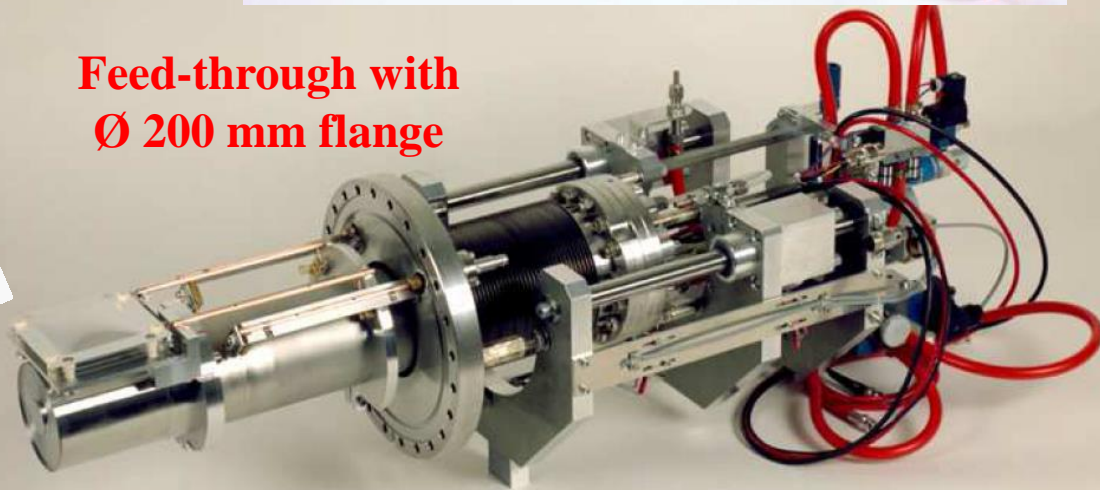

P. Forck et al., DIPAC'97



Summary for Current Measurement



Current is the basic quantity for accelerators!

Transformer: → measurement of the beam's magnetic field

- magnetic field is guided by a high μ toroid
- types: passive (large bandwidth), active (low droop) and dc (two toroids + modulation)
- lower threshold by magnetic noise: about $I_{beam} > 1 \mu\text{A}$
- non-destructive, used for all beams

Faraday cup: → measurement of beam's charge

- low threshold by I/U-converter: $I_{beam} > 10 \text{ pA}$
- totally destructive, used for low energy beams

Scintillator, → measurement of the particle's energy loss

IC, SEM:

- particle counting (Scintillator)
- secondary current: **IC** from gas ionization or **SEM** sec. e^- emission surface
- no lower threshold due to single particle counting
- partly destructive, used for high energy beams

Appendix: The Accelerator Facility at GSI

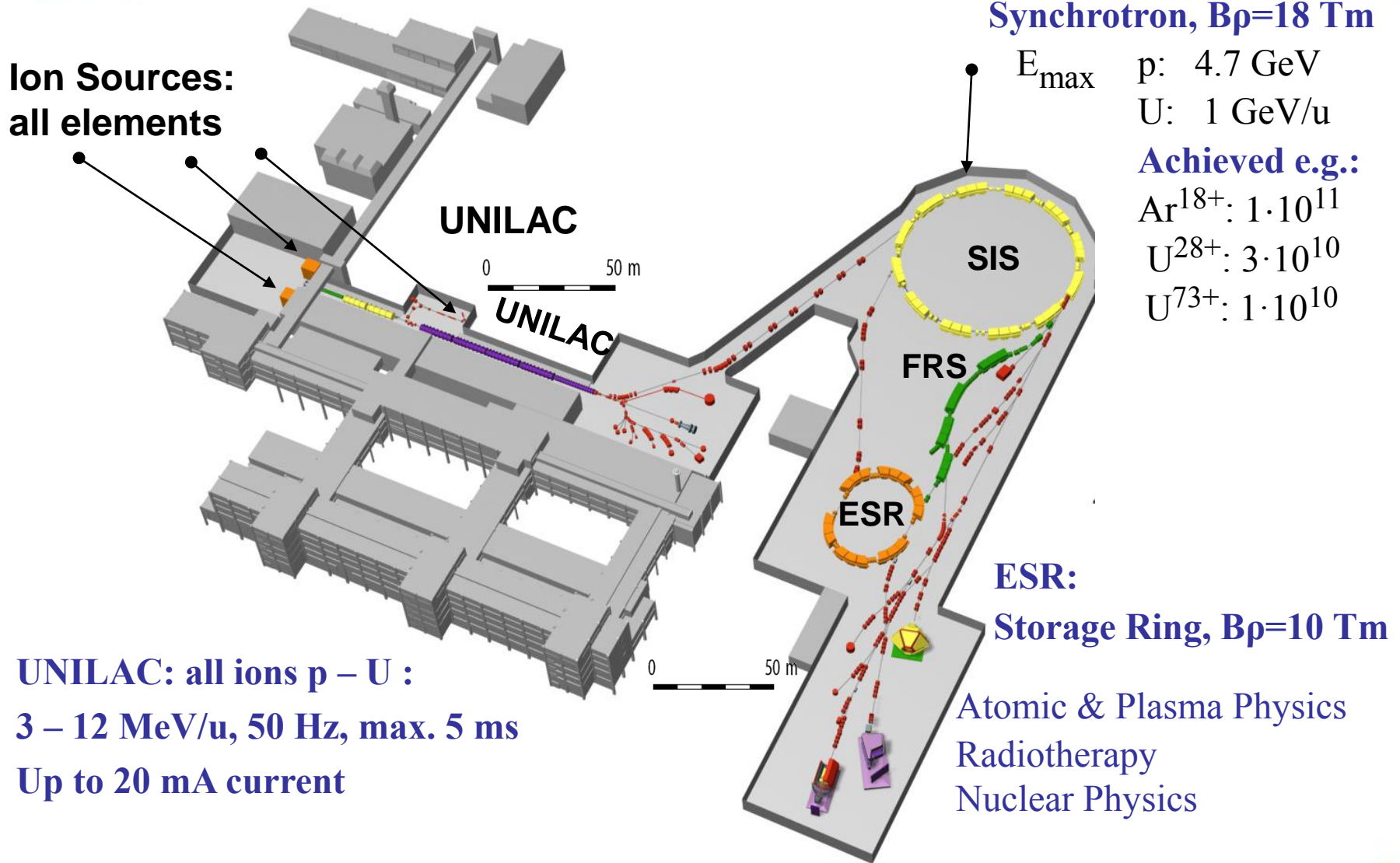

Appendix: Beam Instruments at GSI Accelerator Facility



Ion Sources:
all elements

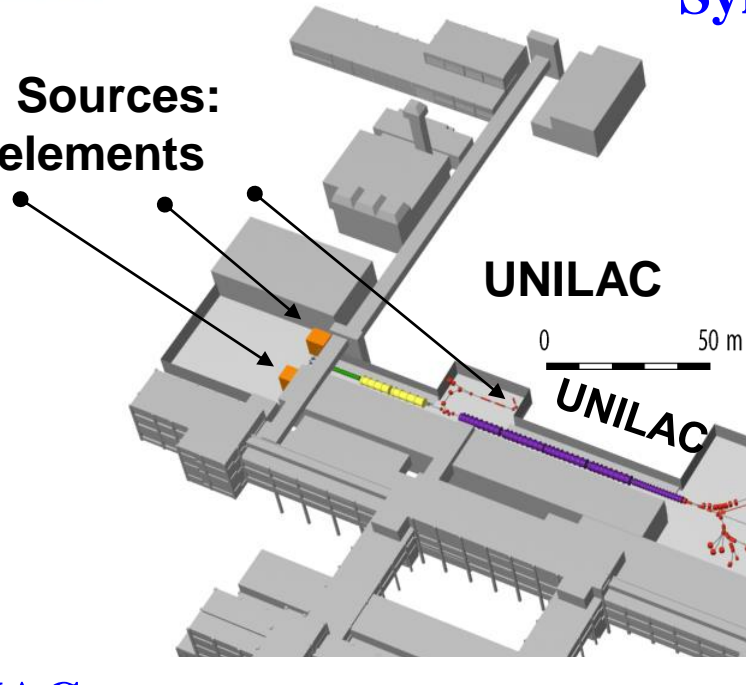

Synchrotron: Current: 2 DCCT, 1 ACCT, 1 FCT
 Profile: 1 SEM-Grid, 1 IPM, 1 Screen
 Position: 16 BPM
 Tune, mom. spread: 1 Exciter + BPM
 1 Schottky

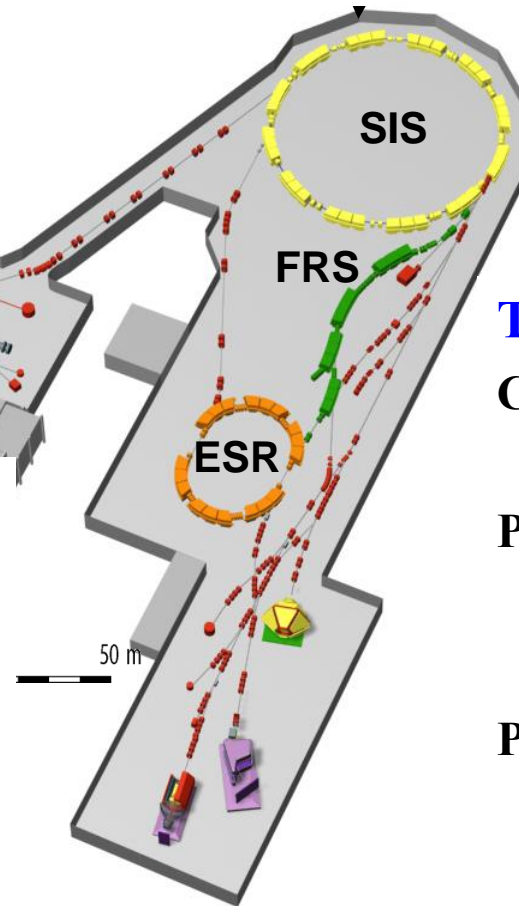

Transport Lines:

Current: 8 FCT
 15 Part. Detec.
 Profile: 10 SEM-Grid
 26 MWPC
 18 Screens
 Position: 8 BPM

LINAC:

Current: 52 transformers, 30 Faraday-Cups
 Profile: 81 SEM-Grids, 6 BIF
 Position & phase: 25 BPM
 Trans. emittance: 9 Slit-Grid, 1 pepper-pot
 Long. emittance: 3 devices of different type

Appendix: UNILAC at GSI: Current Measurement

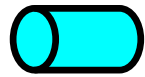

Faraday Cup: for low current measurement and beam stop, total 30

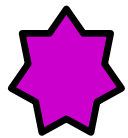

Transformer ACCT: for current measurement and transmission control
total 52 device

They are used for alignment and interlock generation

Transfer to
Synchrotron

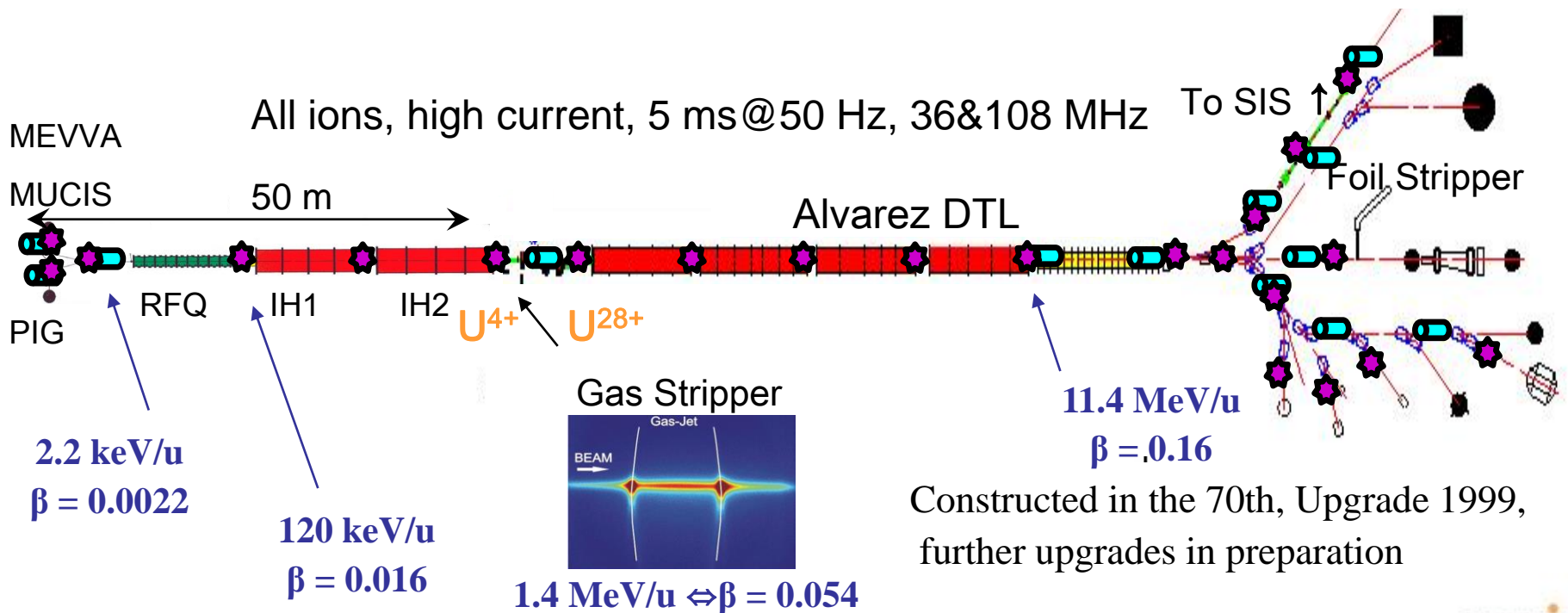

Appendix: GSI Heavy Ion Synchrotron: Overview



acceleration

rf cavity,
quadrupoles, dipoles



Important parameters of SIS-18

Ion (Z)	1 → 92 (p to U)
Circumference	216 m
Inj. type	Multiturn
Injection energy	11 MeV/u
Max. final energy	≈ 2 GeV/u
Ramp duration	0.1 → 1.5 s
Acc. RF	0.8 → 5 MHz
Harmonic	4 (= # bunches)
Bunching factor	0.4 → 0.08
Beam current	10 μA to 100 mA

injec-
tion

extrac-
tion



commissioning 1991





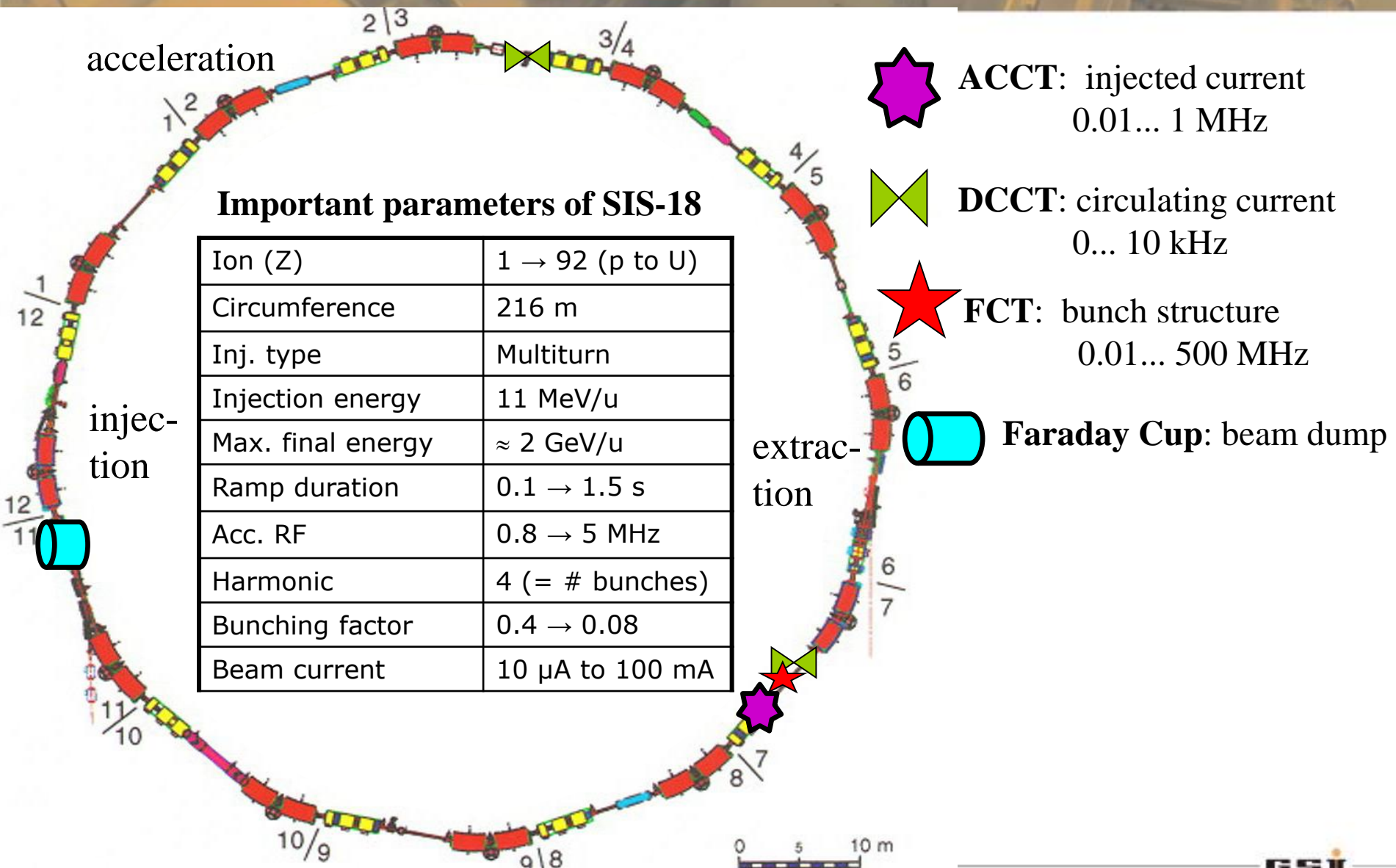

Appendix: GSI Heavy Ion Synchrotron: Current Measurement



Important parameters of SIS-18

Ion (Z)	1 → 92 (p to U)
Circumference	216 m
Inj. type	Multiturn
Injection energy	11 MeV/u
Max. final energy	≈ 2 GeV/u
Ramp duration	0.1 → 1.5 s
Acc. RF	0.8 → 5 MHz
Harmonic	4 (= # bunches)
Bunching factor	0.4 → 0.08
Beam current	10 μA to 100 mA

-  **ACCT:** injected current
0.01... 1 MHz
-  **DCCT:** circulating current
0... 10 kHz
-  **FCT:** bunch structure
0.01... 500 MHz
-  **Faraday Cup:** beam dump

Appendix: 3rd Generation Light Sources



Soleil, Paris, $E_{electron} = 2.5$ GeV, $C = 354$ m

3rd Generation Light Sources:

Synchrotron-based

with $E_{electron} \approx 1 \dots 8$ GeV

Light from undulators & wigglers, dipoles,
with $E_{\gamma} < 10$ keV (optical to deep UV)

Users in:

- Biology
(e.g. protein crystallography)
- Chemistry
(e.g. observation of reaction dynamics)
- material science
(e.g. x-ray diffraction)
- Basic research in solid state and atomic physics

Unique setting: intense, broad-band light emission (monochromator for wavelength selection)

National facilities in many countries, some international facilities.

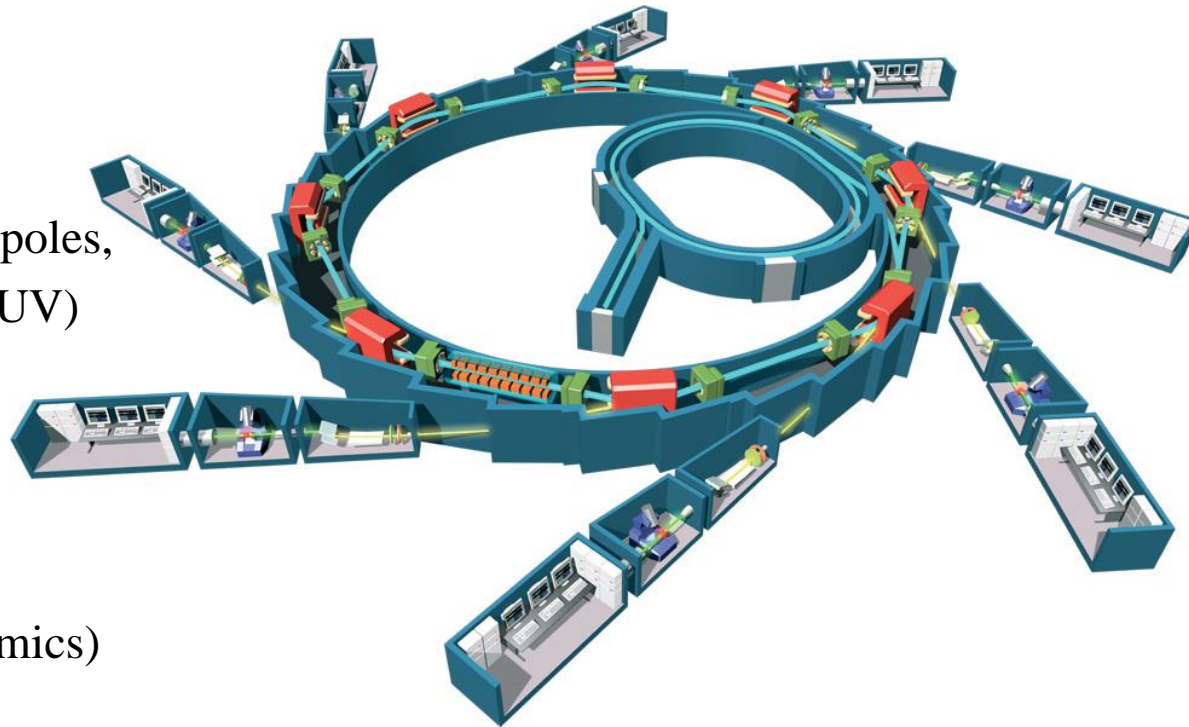

Appendix: The Spanish Synchrotron Light Facility ALBA



3rd generation Spanish national synchrotron light facility in Barcelona



Layout:

Beam lines: up to 30
Electron energy: 3 GeV
Top-up injection
Storage ring length: 268 m
Max. beam current: 0.4 A
Commissioning in 2011



Talk by Ubaldo Iriso: at DIPAC 2011, adweb.desy.de/mpy/DIPAC2011/html/session.htm

see also www.cells.es/Divisions/Accelerators/RF_Diagnostics/Diagnostics

Appendix: The Spanish Synchrotron Light Facility ALBA: Overview

3rd generation Spanish national synchrotron light facility in Barcelona

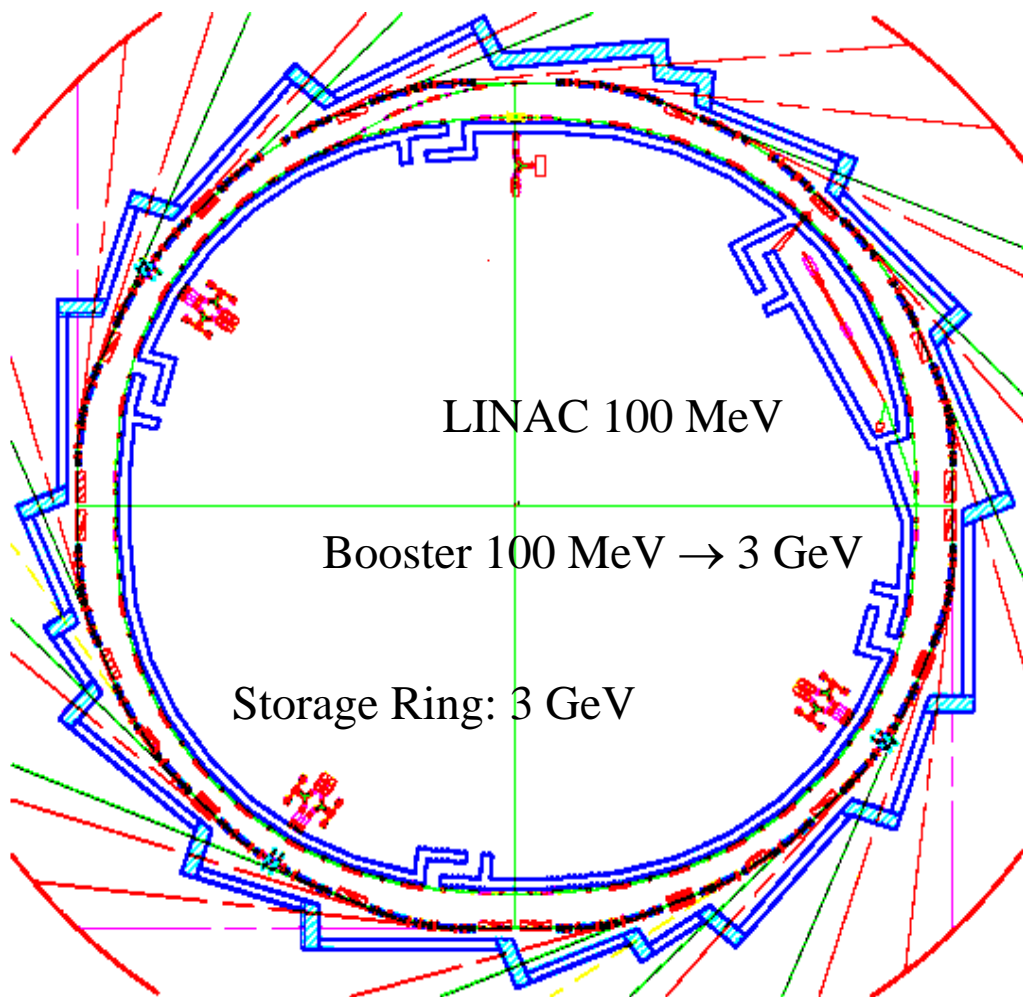

Layout:

- Beam lines: up to 30
- Electron energy: 3 GeV
- Top-up injection
- Storage ring length: 268 m
- Max. beam current: 0.4 A
- Commissioning in 2011

From U. Iriso, ALBA

Appendix: The Synchrotron Light Facility ALBA: Current Meas.

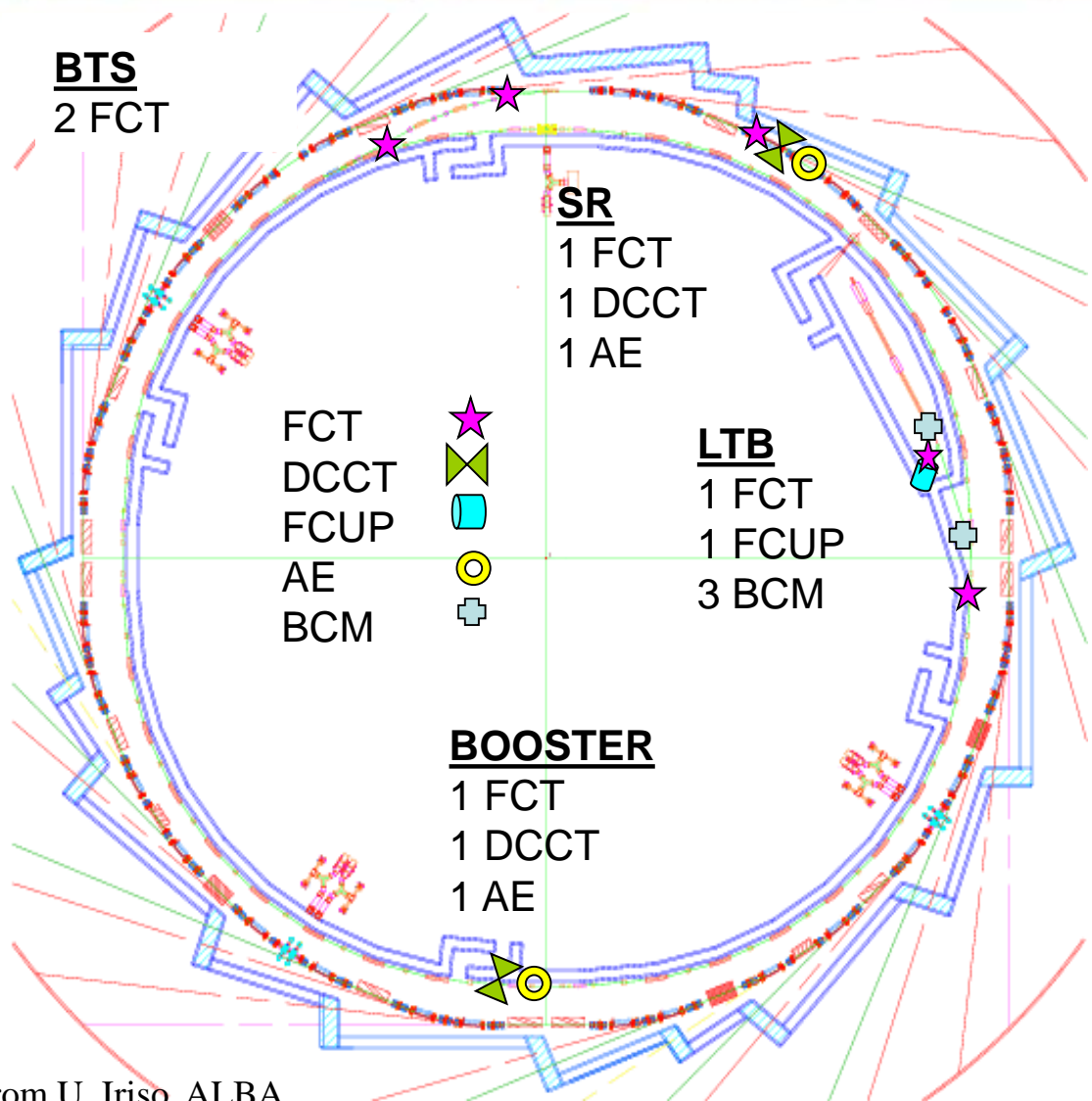

Beam current:

Amount of electrons accelerated, transported and stored

- Several in transport lines
- One per ring

Abbreviation:

FCT: Fast Current Transformer

DCCT: dc transformer

FCUP: Faraday Cup

AE: Annular Electrode

BCM: Bunch Charge Monitor

Remark:

AE: Annular Electrode
i.e. circular electrode acting like a high frequency pick-up

From U. Iriso, ALBA

