

Linac JUAS lecture summary

JUAS 2016

LINACS



Jean-Baptiste Lallement, Veliko Dimov

BE/ABP – CERN

jean-baptiste.lallement@cern.ch

<http://lalleme.web.cern.ch/lalleme/Juas2016/>

Part1: Introduction to Linacs

Linac is the acronym for Linear accelerator, a device where charged particles acquire energy moving on a linear path. There are more than 20'000 linacs in the world – Industry, Research, Medicine.

We can find 2 different types of linacs:

- **Static linacs** are limited by field breakdown to few MeV. Nowadays, they are still used as a very first stage of acceleration. Example of the Cockcroft-Walton.
- **Time varying linacs**
 - **Induction linacs** (not very spread) where a time varying magnetic field generates an electric field. Few MeV energy gain – Several kA beam current.
 - **RF Linacs.**

In an RF linac, the beam is accelerated by time dependent radio-frequency electromagnetic fields. The energy gain depends on the electric field seen by the particles (where and when), their mass and their charge.

The first formal proposal and experimental test of an RF linac was made by **Rolf Wideröe in 1928**, but linear accelerators that were useful for nuclear and elementary particle research did not appear until after the development of microwave technology in World War II when high frequency power generators, developed for radar application, became available. At that time, **Luis Alvarez** proposed an accelerator based on a linear array of drift tubes enclosed in a high-Q cylindrical cavity. Modern linacs were born.

Proton Linacs:

At low energy: Injector to synchrotrons, stand-alone applications.
+ Synchronicity in the range of velocity increase.

At high energy: Production of secondary beams (neutrons, neutrinos, radioactive ions).
+ Average beam current
- Cost / MeV

Electron Linacs:

At low energy: Conventional and well known e- linacs.
+ Very simple and compact.

At high energy: Linear colliders. ONLY option for very high energies!
+ No energy loss due to synchrotron radiation.

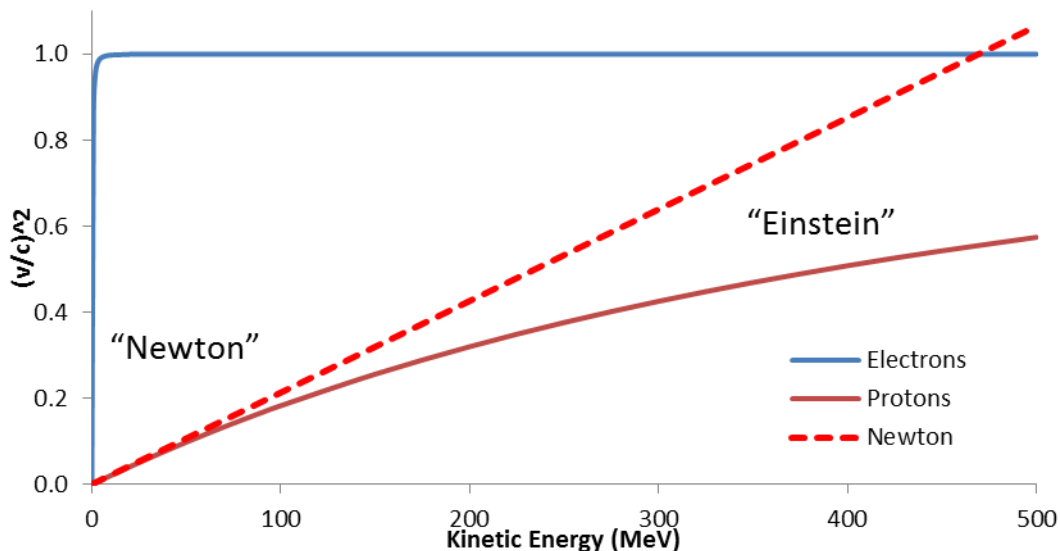

Designing an RF linac consists in:

- Cavity design – Field pattern inside the cavity / Minimize Ohmic losses
- Beam dynamics – Synchronicity / keep good beam quality

Travelling wave cavities are used for ultra-relativistic particles. The wave propagates along the beam direction. Particle whose velocity is close to the phase velocity exchanges energy with it. Difficult to use for ions with $\beta < 1$: Constant cell length does not allow for synchronism and long structures do not allow for sufficient transverse focusing.

Standing wave cavities: closing the walls on both side of the wave guides or disc-loaded structure yields multiple reflections of the waves. After a certain time a standing wave pattern is established. Do to boundary conditions, only certain modes with distinct frequencies are possible in this resonator.

Cavity Parameters

- Average electric field: E_0 , average electric field on axis in the direction of the beam propagation at a given time when $E(t)$ is max. How much field is available for acceleration.

$$E_0 = \frac{1}{L} \int_0^L E(0,0,z) dz$$

- Shunt impedance: Z , ratio of the average electric field squared (E_0^2) to the power (P) per unit length (L) dissipated on the walls surface. How well the RF power is concentrated in the useful region.

$$Z = E_0^2 \cdot \frac{L}{P} \quad \text{or} \quad Z = E_0^2 \cdot \frac{dL}{dP}$$

- Quality factor: **Q**, ratio of the stored energy (U) to the power lost on the wall (P) in one RF cycle.

$$Q = \frac{2\pi \cdot f}{P} \cdot U$$

- Filling time: **t_f**,
 - For Travelling Wave: Time needed for the electromagnetic energy to fill the cavity of length L.

$$t_F = \int_0^L \frac{dz}{v_g(z)}$$

- For Standing Wave: Time it takes for the field to decrease by 1/e after the cavity has been filled. How fast the stored energy is dissipated on the walls.

$$t_F = \frac{2Q}{\omega}$$

- Transit time factor: **T**, ratio of the energy gained in the time varying RF field to that in a DC field. Measure of the reduction in energy gain caused by the sinusoidal time variation of the field in the gap.

$$T = \frac{\int_{-L/2}^{L/2} E_z(z) \cdot e^{-j\left(\frac{\omega z}{\beta c}\right)} dz}{\int_{-L/2}^{L/2} E_z(z) \cdot dz} = \frac{\int_{-L/2}^{L/2} E_z(z) \cdot e^{-j\left(\frac{\omega z}{\beta c}\right)} dz}{E_0 L}$$

$$\Delta W = q \cdot E_0 \cdot L \cdot T \cdot \cos(\phi)$$

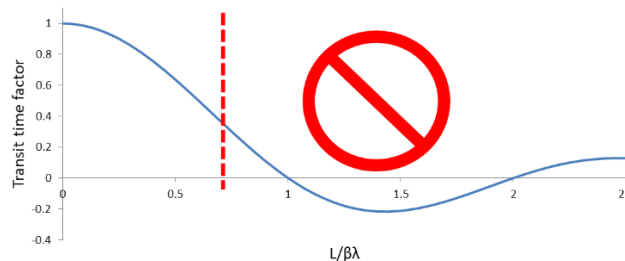

- Effective shunt impedance: **ZT²**, while the shunt impedance measures if the structure design is optimized, the effective shunt impedance measures if the structure is optimized and adapted to the velocity of the particle to be accelerated.

$$ZTT = (E_0 T)^2 \cdot \frac{L}{P}$$

The peak surface electric field and magnetic field are important constraints in cavity design.

In normal conduction cavities, too large peak surface electric field can result in electric breakdown. The **Kilpatrick criterion** is often used as the basis for the peak surface electric field limit in normal conducting cavities.

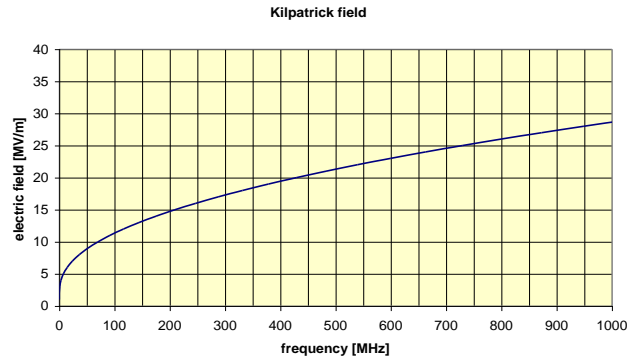

In superconducting cavities high electric field cause field emission, which produces electrons in the cavity volume that absorb RF energy and create additional power loss. The surface magnetic fields correspond to surface currents that produce resistive heating -> **Quench**.

Part2: Cavities and structures.

In free space, electromagnetic field are TEM type. E and B are perpendicular to each other and to the direction of propagation. In bounded medium (in a cavity) the solution of the equation must satisfy the boundary conditions:

$$\begin{aligned} \vec{E}_{\parallel} &= \vec{0} \\ \vec{B}_{\perp} &= \vec{0} \end{aligned}$$

Cavity modes:

- TE mode (transverse electric): The electric field is perpendicular to the direction of propagation in a cylindrical cavity. \mathbf{TE}_{mn}

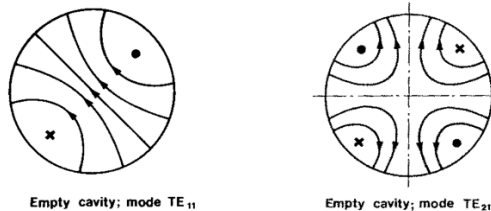

- TM mode (transverse magnetic): The magnetic field is perpendicular to the direction of propagation in a cylindrical cavity. \mathbf{TM}_{mn}

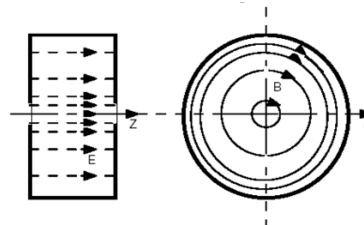

Standing wave modes. For synchronicity and acceleration, particles must be in phase with the E field. During one RF period, the particle travels over a distance of $\beta\lambda$.

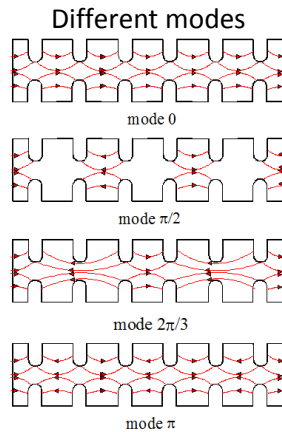

Mode	L
2π	$\beta\lambda$
$\pi/2$	$\beta\lambda/4$
$2\pi/3$	$\beta\lambda/3$
π	$\beta\lambda/2$

Beta.Lambda – $\beta\lambda$ – The linac unit of length: In linacs, we often express the distance between gaps, between periods or between magnets in terms of multiple of $\beta\lambda$. The master clock is given by the RF frequency. At every period T , the field pattern in the cavities is identical. During that time, a particle with a velocity βc , will travel over a distance of $(T \cdot \beta c) = \beta \cdot c/f = \beta\lambda$
During one RF period, a particle travels over $\beta\lambda$.

Basic accelerating structures:

- **RFQ** Radio-Frequency Quadrupole: TE₂₁ mode. Alternating voltage on the electrodes produces a focusing channel. Longitudinal modulation of the electrodes produces a field in the direction of the beam propagation and accelerate the beam. **Transverse focusing – Bunching – Acceleration**

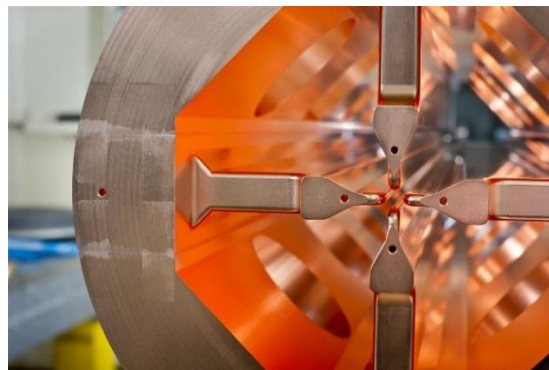

- **IH** Interdigital H structure: TE₁₁ mode. Stem on alternating side of the drift tube force longitudinal field between the drift tubes. Focalisation outside the drift tubes. **Very good shunt impedance.**



- **DTL** Drift Tube Linac: TM10 mode. 2π mode structure. Particles are inside the tubes when the electric field is decelerating. Quadrupoles can be fit inside the drift tube. Strong focusing channel-> **Ideal for high current.**

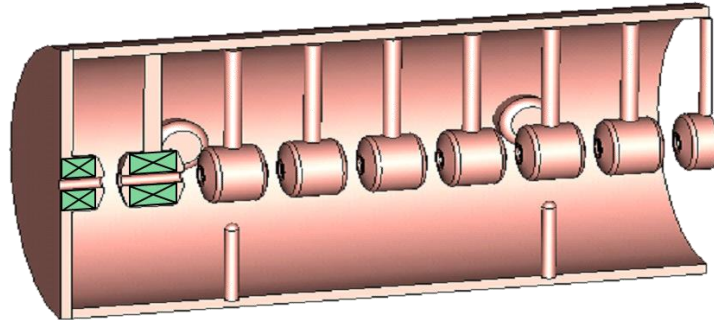

- **CCDTL** Coupled Cavity DTL: Short DTL cavities coupled together. Toward a standardisation of the drift tube design. **Not for too low beta.**

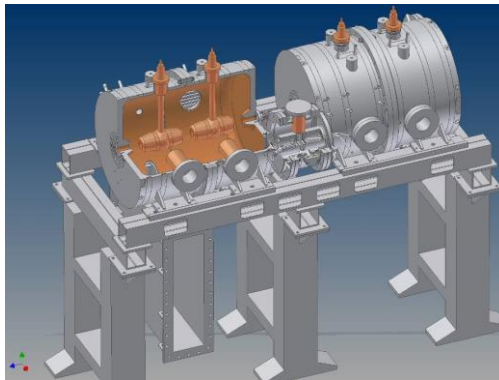

- **SCL** Side Coupled Cavity: Multi cell structure in $\pi/2$ mode for the structure, π mode for the beam. High frequencies. **Ideal for high beta particles.**

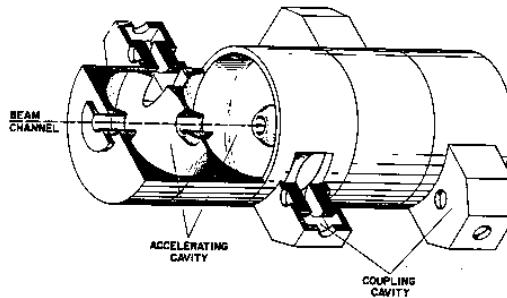

- **PIMS** Pi Mode Structure: Mode is in the name. **Type of cavities used at the LEP!** Can also be used for protons (medium beta).

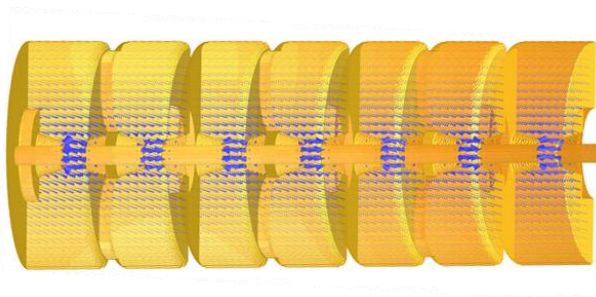

- **Superconducting cavities zoo:** Low losses, high efficiency and effective energy gain.
 - **Elliptical:** π mode – 350-700 MHz for protons – up to 3 GHz for e-.



- **Spokes, HWR** Half wave resonators, **QWR** Quarter wave resonators: From 1 to 4 gaps. Short cavities such that focusing in between. Ideal for low beta – High current (CW).

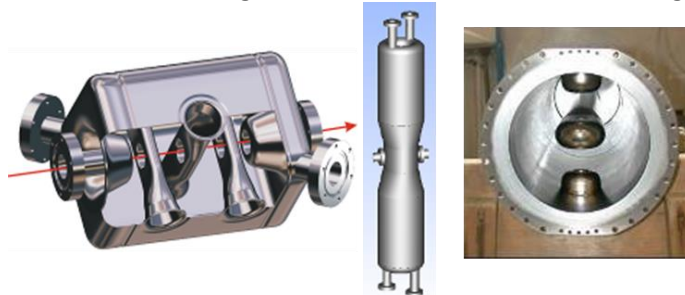

Cavities characteristics summary, to take with caution. **Choice of linac cavities depends on many criterion:** Particle type, current, duty factor, frequency, energies (in and out), expertise in the lab, collaboration with external institutes, possibility of upgrade...

Cavity Type	Beta Range	Frequency	Particles
RFQ	Low! – 0.1	40-500 MHz	Protons, Ions
IH	0.02 – 0.08	40-100 MHz	Ions (Protons)
DTL	0.05 – 0.5	100-400 MHz	Protons, Ions
SCL	0.5 – 1 (ideal is 1)	600-3000 MHz	Protons, Electrons
HWR-QWR-Spokes	0.02-0.5	100-400 MHz	Protons, Ions
Elliptical	> 0.5-0.7	350 – 3000 MHz	Protons, Electrons

Part3: Beam dynamics.

Beam dynamics defines how to accelerate and focus the beam.

A particle bunch is characterized by its distribution in the 6D phase space. Horizontal, vertical and longitudinal. In Linac convention: z in the direction of beam propagation, y vertical pointing up, x horizontal pointing left (going with the beam). A particle is fully defined by its 6 coordinates x, x', y, y', z, z'.

One can define an ellipse in the phase space with the Twiss parameters α , β , γ and the emittance ϵ . $\epsilon = E / \pi$, is the area of the ellipse divide by π .

The ellipse equation is:

$$\gamma x^2 + 2\alpha x x' + \beta (x')^2 = \epsilon$$

Where

$$\beta\gamma - \alpha^2 = 1$$

- α is a measure of the focalisation
- β proportional to the square of beam size. Always positive
- γ proportional to the square of divergence. Always positive

And the RMS emittance is define by

$$\epsilon_{rms} = \sqrt{\overline{x^2} \overline{x'^2} - \overline{xx'}^2}$$

Emittance ellipse

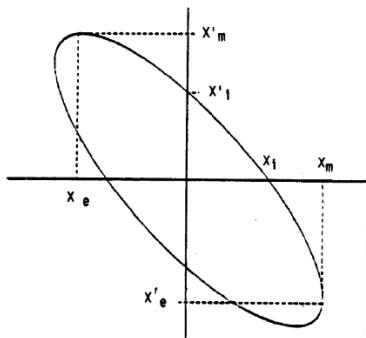

$$x_m = \sqrt{\beta\epsilon} \quad \text{and} \quad x'_m = \sqrt{\gamma\epsilon}$$

In the absence of non-linear forces, the ellipse area is constant: Liouville's theorem.
Normalised emittance: $\beta\gamma\epsilon$ – ($\beta\gamma$ relativistic)

Longitudinal dynamics

Linac convention: Field is maximum for a 0° phase.

Energy gain:

$$\Delta W = q \cdot E_0 \cdot L \cdot T \cdot \cos(\phi)$$

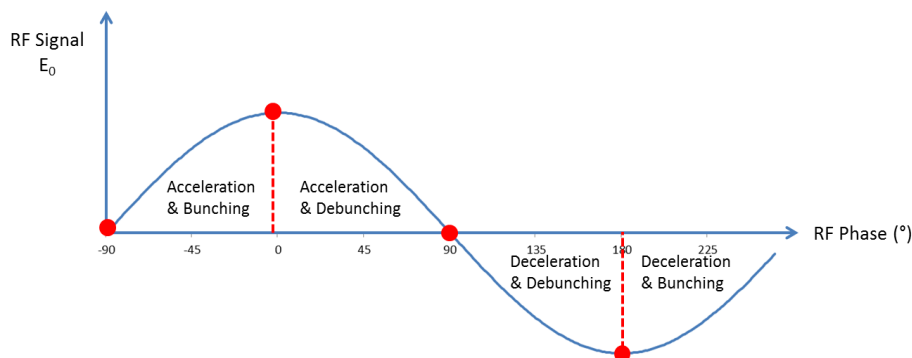

Separatrix

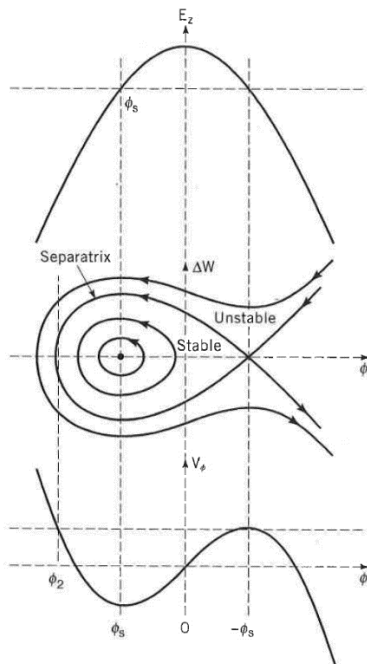

Defines stable and unstable areas:

Stable area: The particles are captured in the bucket. They are accelerated and bunched.

The area of the bucket depends on the effective accelerating field and the synchronous phase.

Separatrix equation:

$$\frac{\omega}{2mc^3 \beta_s^3 \gamma_s^3} (\Delta W)^2 + qE_0 T [\sin(\varphi_s + \Delta\varphi) + \sin \varphi_s - (2\varphi_s + \Delta\varphi) \cos \varphi_s] = 0$$

Longitudinal phase advance: The characterisation of the longitudinal forces that keep the beam bunched.

Longitudinal phase advance per unit of length

$$k_{0l} = \sqrt{\frac{2\pi q E_0 T \sin(-\varphi_s)}{mc^2 \beta_s^3 \gamma_s^3 \lambda}}$$

Longitudinal phase advance per period (where $N \beta \lambda$ is a period)

$$\sigma_{0l} = \sqrt{\frac{2\pi q E_0 T N^2 \lambda \sin(-\varphi_s)}{mc^2 \beta_s^3 \gamma_s^3}}$$

It is important to adapt the cavity geometry to the velocity of the particle: **Synchronicity**.

- Case1: $\beta_s = \beta_g \ll 1$ -> structure is continuously changing to adapt to the synchronous particle velocity change (ex. DTL).
- Case2: $\beta_s \approx \beta_g$ -> structure is adapted in step to the synchronous particle velocity change. Phase slippage (ex. elliptical cavities for protons).
- Case3: $\beta_s = \beta_g \approx 1$. Constant structure.

Transverse dynamics

Various type of focusing element and focusing channels can be found: Solenoids, quadrupoles, bending edges... Doublets, FFDD, triplet...

A beam is matched to a regular focusing channel when after every period, the Twiss parameters, α , β and γ are identical.

The transverse phase advance defines the transverse "focusing strength". It can be calculated from the beta function (the smaller the beta function, the smaller the beam size, larger the phase advance). Need more focusing to "compress" the beam!

$$\sigma_t = \int_0^z \frac{1}{\beta(z)} dz$$

Transverse phase advance (zero current) for a FD and FFDD channels.

Lattice	Period	σ_0 (per period)	k_0 per meter
FD	2L	$\frac{qGLL}{\beta\gamma mc}$	$\frac{qGl}{2\beta\gamma mc}$
FFDD	4L	$\frac{2\sqrt{2}qGLL}{\beta\gamma mc}$	$\frac{\sqrt{2}qGl}{2\beta\gamma mc}$

In presence of acceleration (while bunching), the RF field tends to defocus the beam transversely. This effect is called RF defocusing.

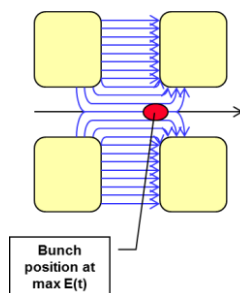

3 Main reasons for RF defocusing.

- The fields vary in time as the particles cross the gap.
- The fields acting on the particle depend on the radial particle displacement, which varies across the gap.
- The particle velocity increases while the particle crosses the gap, so that the particle does not spend equal times in each half of the gap.

Phase advance with RF defocusing becomes:

$$k_{ot} = \sqrt{\left(\frac{qGl}{2mc\beta\gamma}\right)^2 - \frac{\pi q E_0 T \sin(-\phi)}{mc^2 \lambda (\beta\gamma)^3}}$$

Where the negative term depends on EOT (field level) and $\sin(-\phi)$. We can have a transverse focusing effect when going to $0^\circ < \phi < 180^\circ$, but the beam would then get debunched longitudinally ...

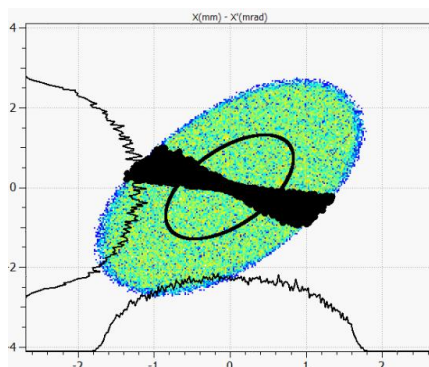

Black particle were selected on the line at the starting point of a FODO channel with RF gaps at -90° synchronous phase. After the line, particles that are at the edge of the ellipse, experienced a different phase advance than the ones close to the centre. Their rotation velocity inside the ellipse was changed by the RF defocusing.

Space charge: Particle bunch self-repulsion force. Equally charged particle tends to repel each other. This is the space charge effect. It adds a defocusing force to the beam and decrease the phase advance (both transverse and longitudinal).

The transverse phase advance per meter in presence of space charge is:

$$k_{ot} = \sqrt{\left(\frac{qGl}{2mc\beta\gamma}\right)^2 - \frac{\pi qE_0 T \sin(-\phi)}{mc^2 \lambda (\beta\gamma)^3} - \frac{3Z_0 q I \lambda (1-f)}{8\pi mc^2 \beta^2 \gamma^3 r_x r_y r_z}}$$

The space charge term (negative) depends on the beam current and bunch volume. The space charge effect is not uniform inside a bunch. Centre particles do not see any effect (Gauss Law).

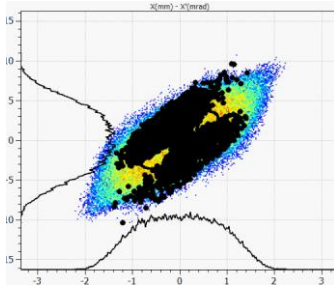

Black particles were selected on the line at the starting point of a FODO channel with space charge calculation included. After only a few periods, their distribution starts to be shuffled. Especially close to the edge of the beam, where the space charge forces are the strongest.