



Injection/Extraction



L. Farvacque, T. Perron

E.S.R.F.

Introduction

- There are a lot of ways to inject/extract particles into/out of an accelerator. The choice of these depends essentially on the accelerator type but may also be imposed by some constraints specific to a given machine.
- It is therefore difficult to describe in an exhaustive manner all possible or existing injection/extraction schemes. The aim of this lecture is to give some general considerations and to illustrate them with some typical examples.
- 3 parts:
 - injection
 - extraction + 2 examples
 - magnetic elements

Injection



- Final stage of transfer of beam from one accelerator (linear or a circular) to another (accelerator or storage ring)
- Goal: achieve the transfer with minimum beam loss (i.e. maximum injection efficiency). This does not only involve putting the injected particles on to the beam path of the machine but also involves getting these particles trapped in the machine acceptances (transverses and longitudinal) so that they can be stored or further accelerated.
- The specific case of the **cyclotrons** will not be addressed in this lecture.
- Injection into a **linear accelerator (linac)** is not a problem, because it is a single pass accelerator. The accelerated beam does not come back to the injection point: It is easy to inject the beam on axis at the entry point of the accelerating structure.
- Injection into a **circular machine** is more delicate because the freshly injected beam again passes the injection point in the following turns: The action of the injection elements should not concern the beam when it comes back after one turn.

Recall: Phase space

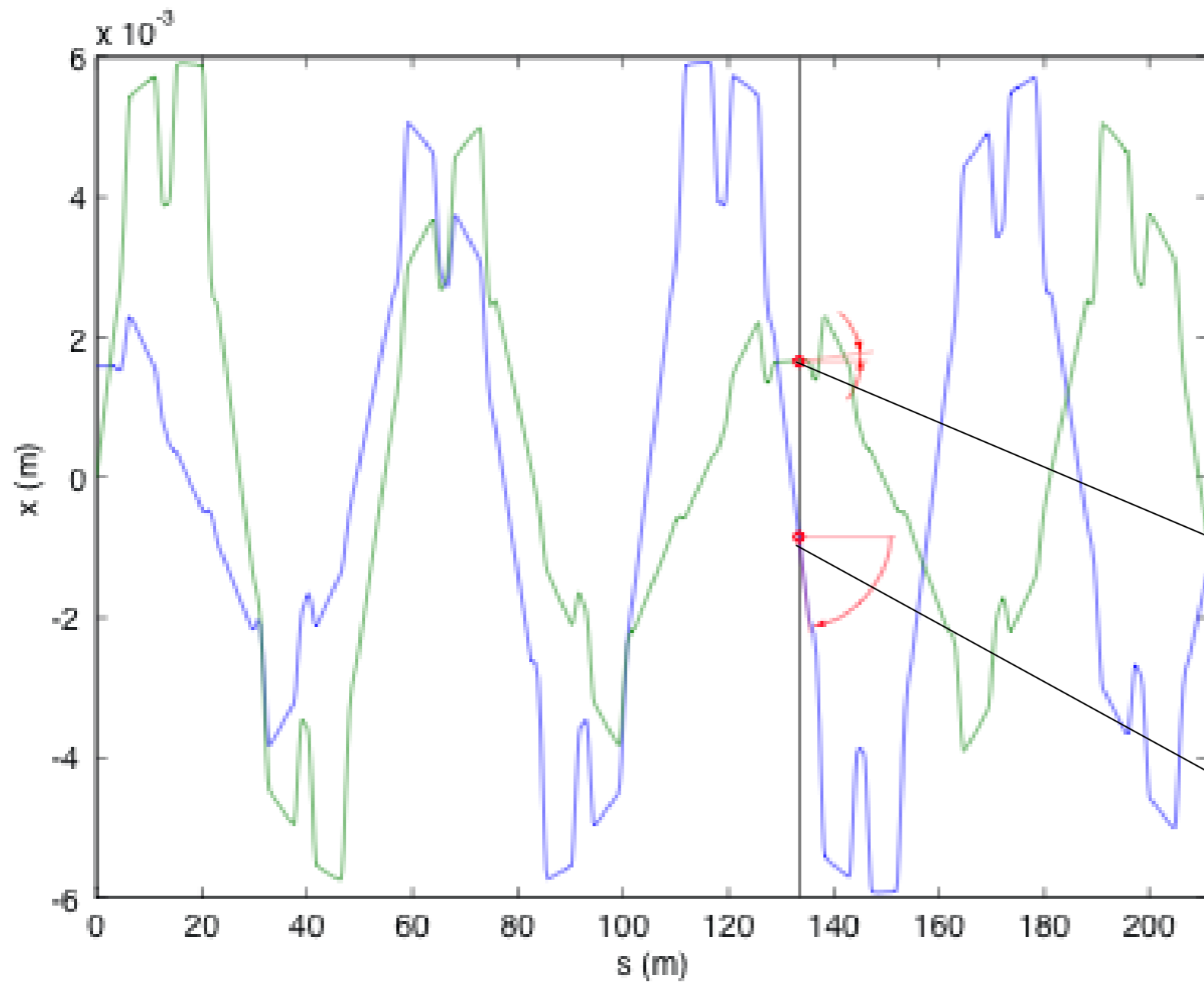

The trajectory of a particle along a circular machine is oscillating around the reference orbit.

At any location along the machine, each trajectory can be represented in phase-space by two coordinates per plane:

$$(x, x' = dx/ds)$$

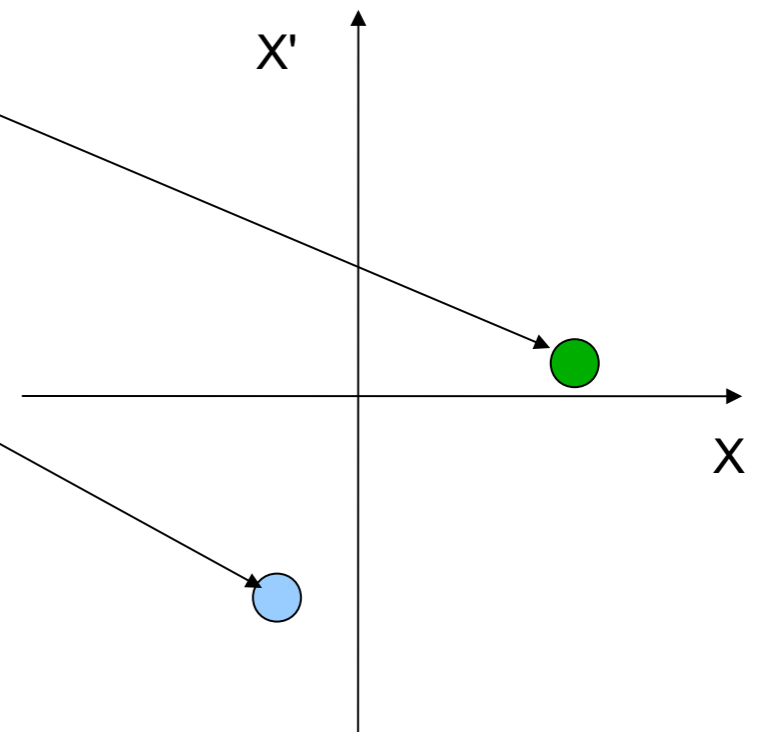

Injection/Extraction

Recall: Phase space

In a circular machine, at a given position s_0 , the motion of a particle turn after turn is represented by an ellipse:

$$\gamma x^2 + 2\alpha x x' + \beta x'^2 = Cst$$

Normalized phase space is defined using the following change of variables.

$$X = \frac{x}{\sqrt{\beta}} \quad X' = x' \sqrt{\beta} + \alpha \frac{x}{\sqrt{\beta}}$$

Phase space trajectories are then circles and keep the same shape along the machine.

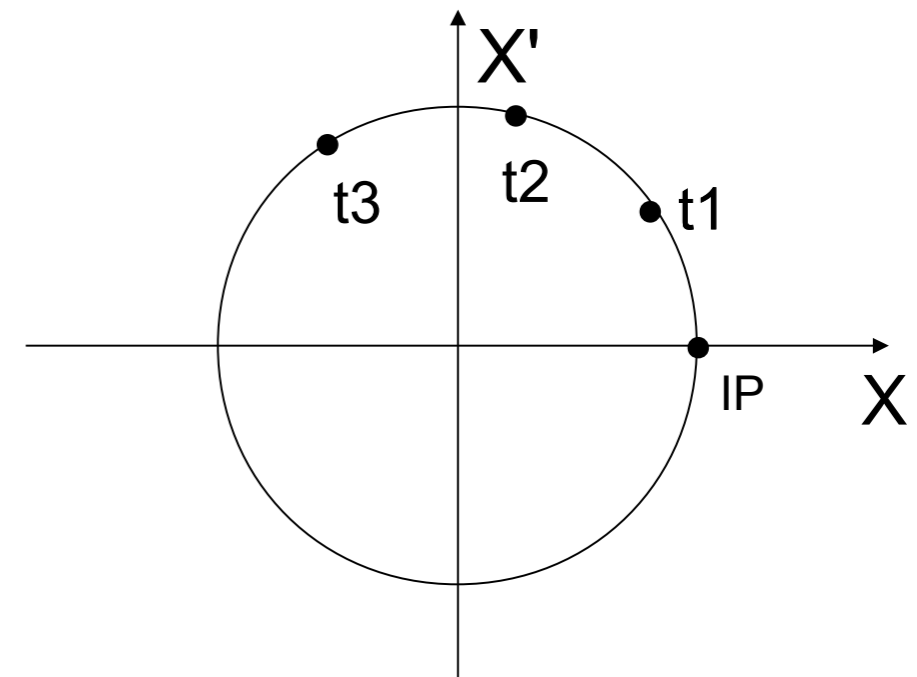
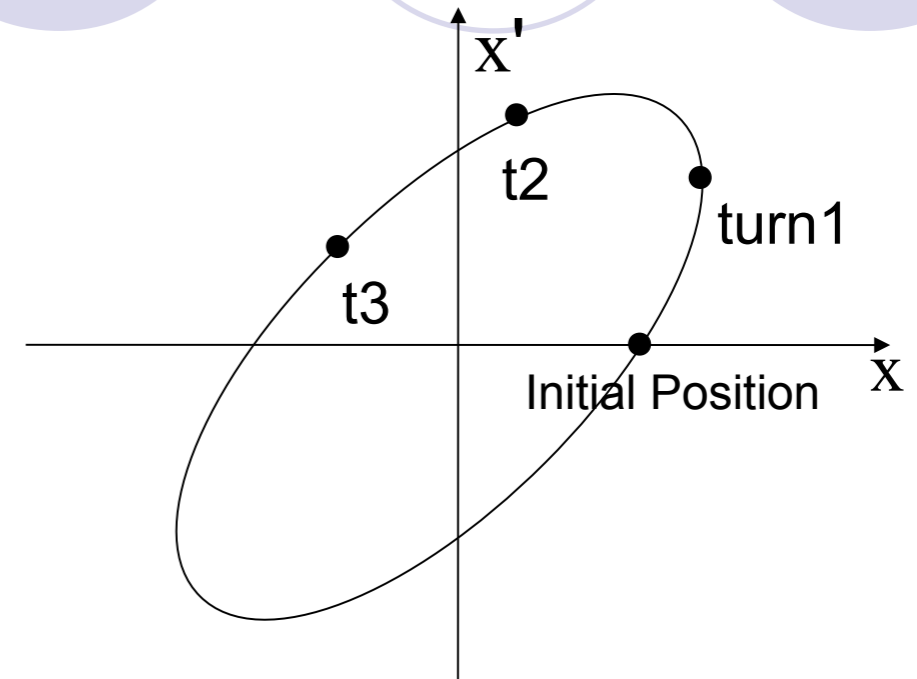

Recall: emittance and beam sizes

A particle beam is often reasonably well described by a two dimensional Gaussian distribution in phase space.

The curves of constant phase space density are then ellipses, with equation:

$$\gamma x^2 + 2\alpha x x' + \beta x'^2 = \epsilon$$

The r.m.s. sizes $\sigma_{x,z}$ of a beam are defined by:

$$\sigma_{x,z} = \sqrt{\beta_{x,z} \cdot \epsilon_{x,z}}$$

with

$\epsilon_{x,z}$: emittance of the beam (invariant)

$\beta_{x,z}$: local beta function

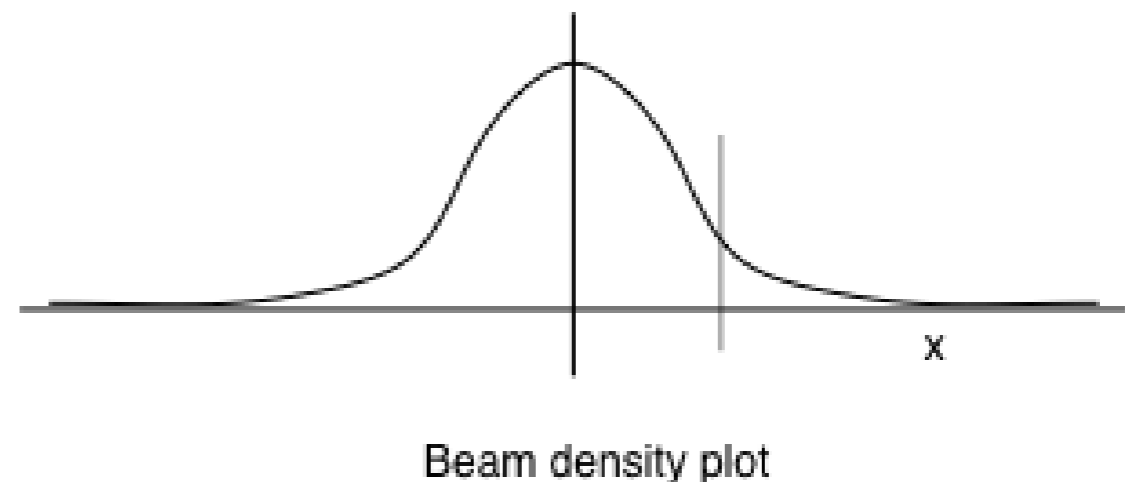
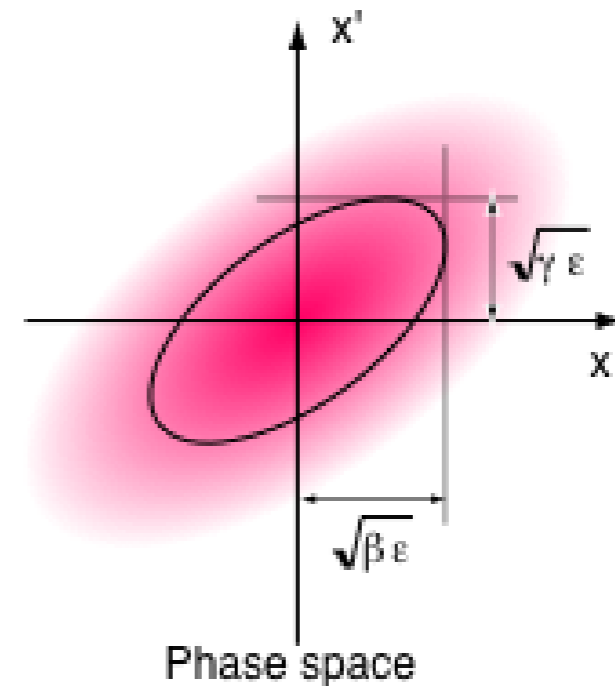

Recall: emittance and beam sizes

- At a place where there is a non-zero dispersion function $D_{x,z}$, one needs to add (quadratically in the case of a gaussian beam) the contribution of the energy spread in the beam $\delta p/p$:

$$\sigma_{x,z} = \sqrt{\beta_{x,z} \cdot \varepsilon_{x,z} + D_{x,z}^2 \cdot \left(\frac{\delta p}{p}\right)^2}$$

- Note: for a Gaussian distribution with r.m.s. σ ,
- 68.3 % of the particles are contained inside $[-\sigma, +\sigma]$
- 95.5 % of the particles are contained inside $[-2\sigma, +2\sigma]$
- 99.7 % of the particles are contained inside $[-3\sigma, +3\sigma]$
- and the Full Width Half Maximum is $\text{FWHM} = 2.35 \sigma$

Recall: Acceptance

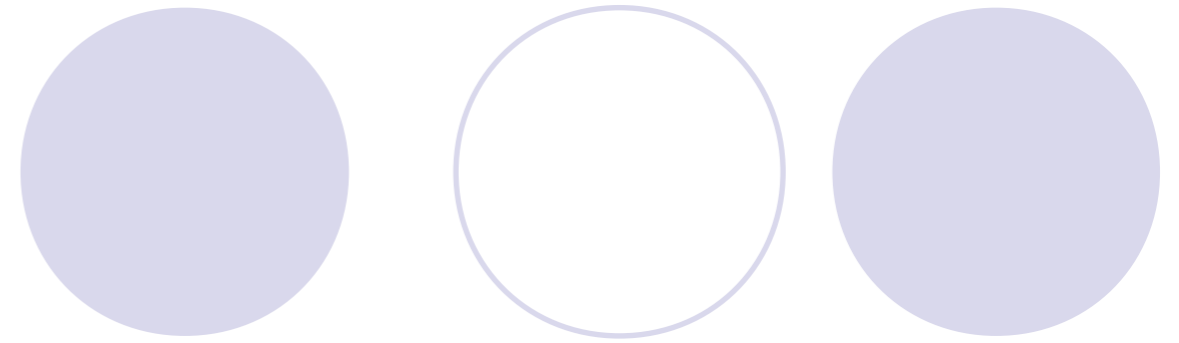

Acceptance is the area in phase space defined by the largest possible amplitude of oscillation.

If a particle is outside the acceptance it will get lost.

The acceptance can be of two types:

- Physical acceptance, defined by the **most limiting aperture in the machine**
- Dynamical acceptance, due to non linear fields driving the beam unstable for large amplitudes.

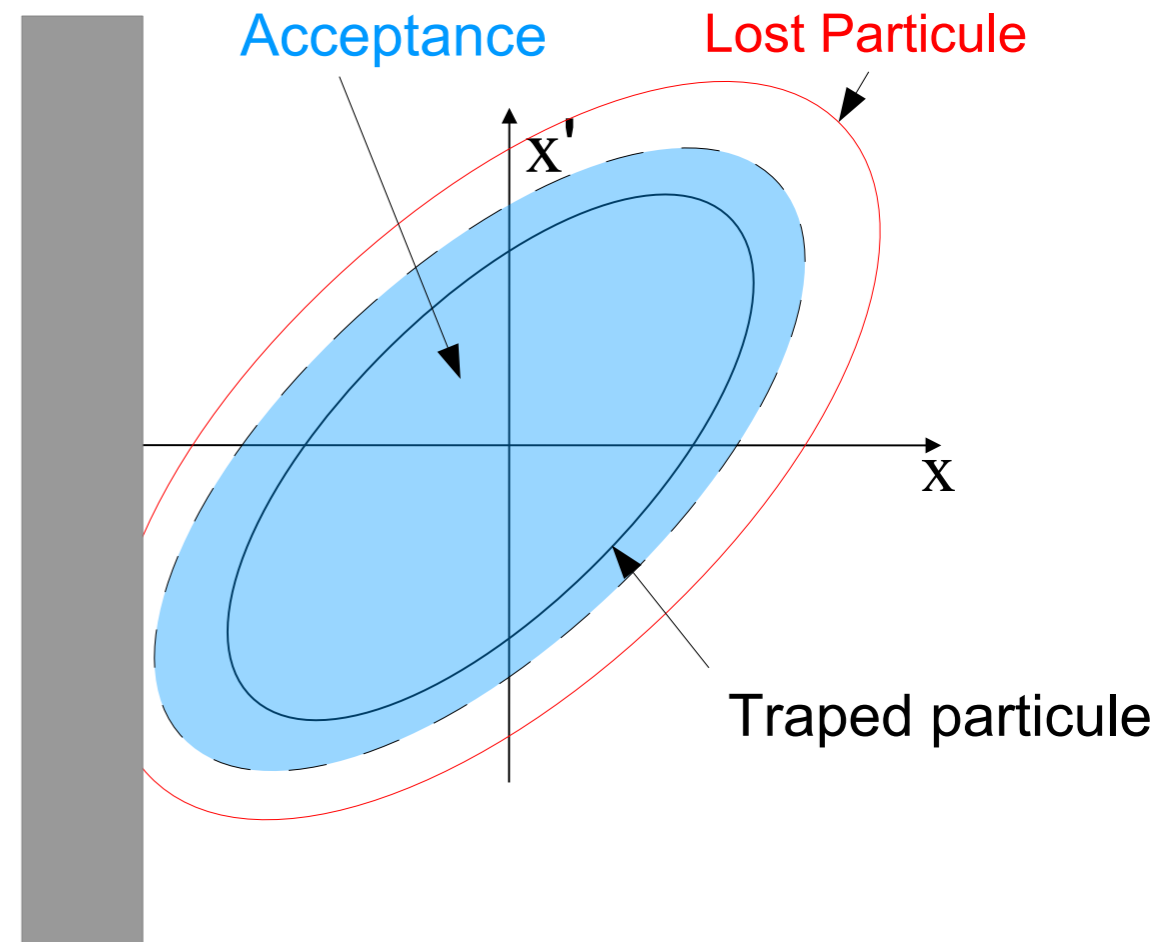

Obstacle (beam pipe for example)

Recall: Liouville Theorem

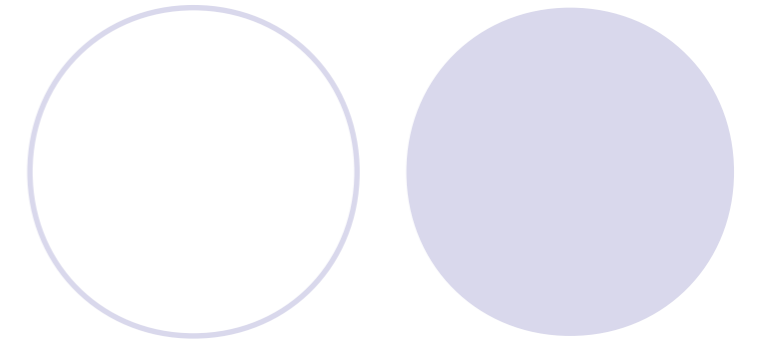

If no damping or radiation, and no space charge effects, beam volume in 6D phase space is constant:

For horizontal phase space during injection, area occupied by the different beams is constant :

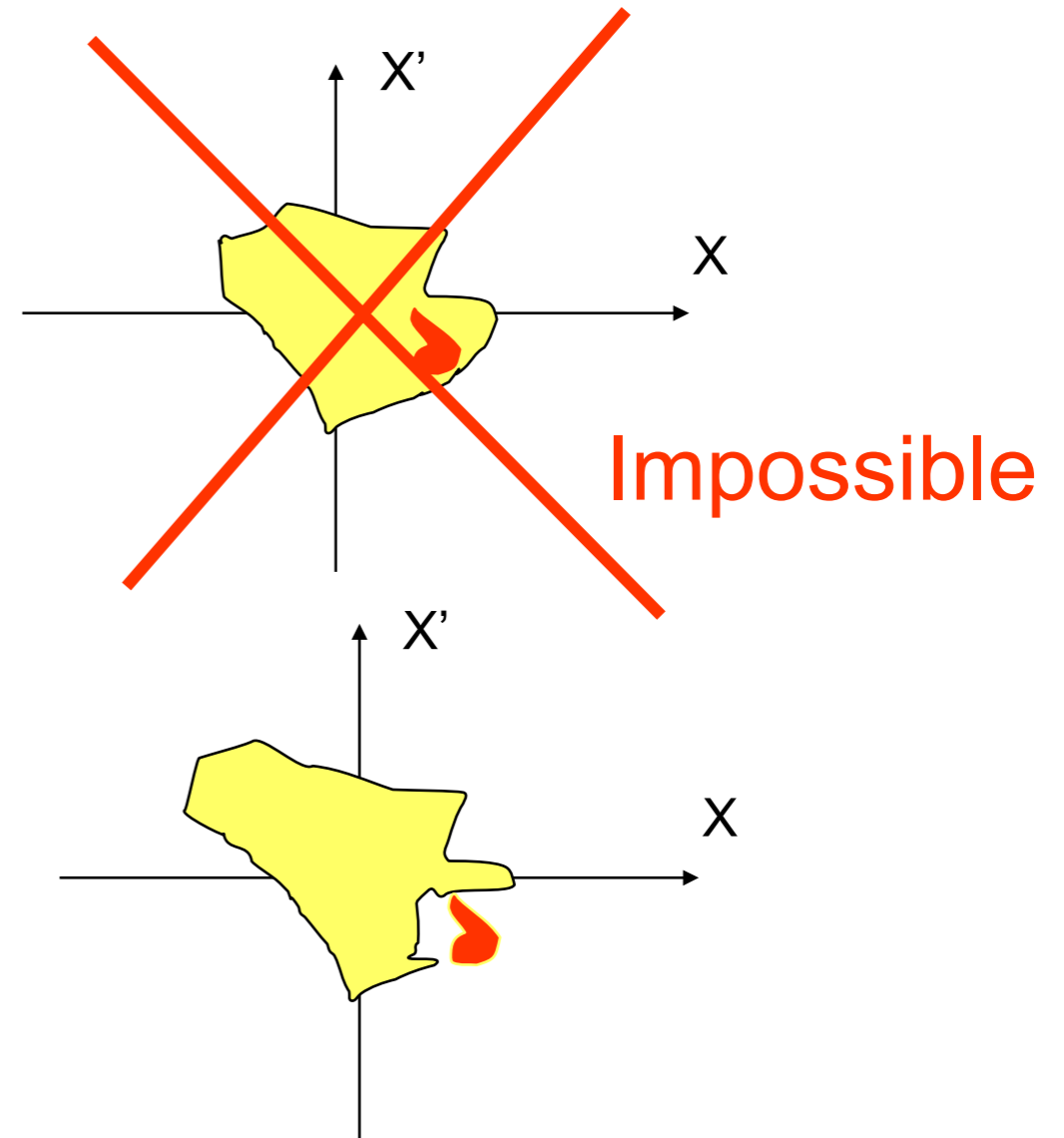
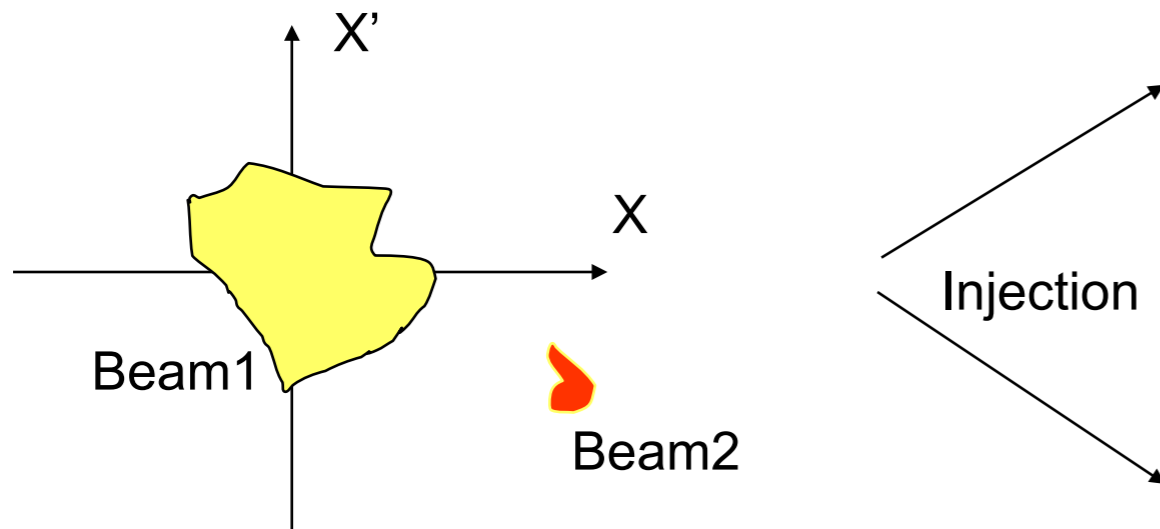

No superposition possible

Injection, real space

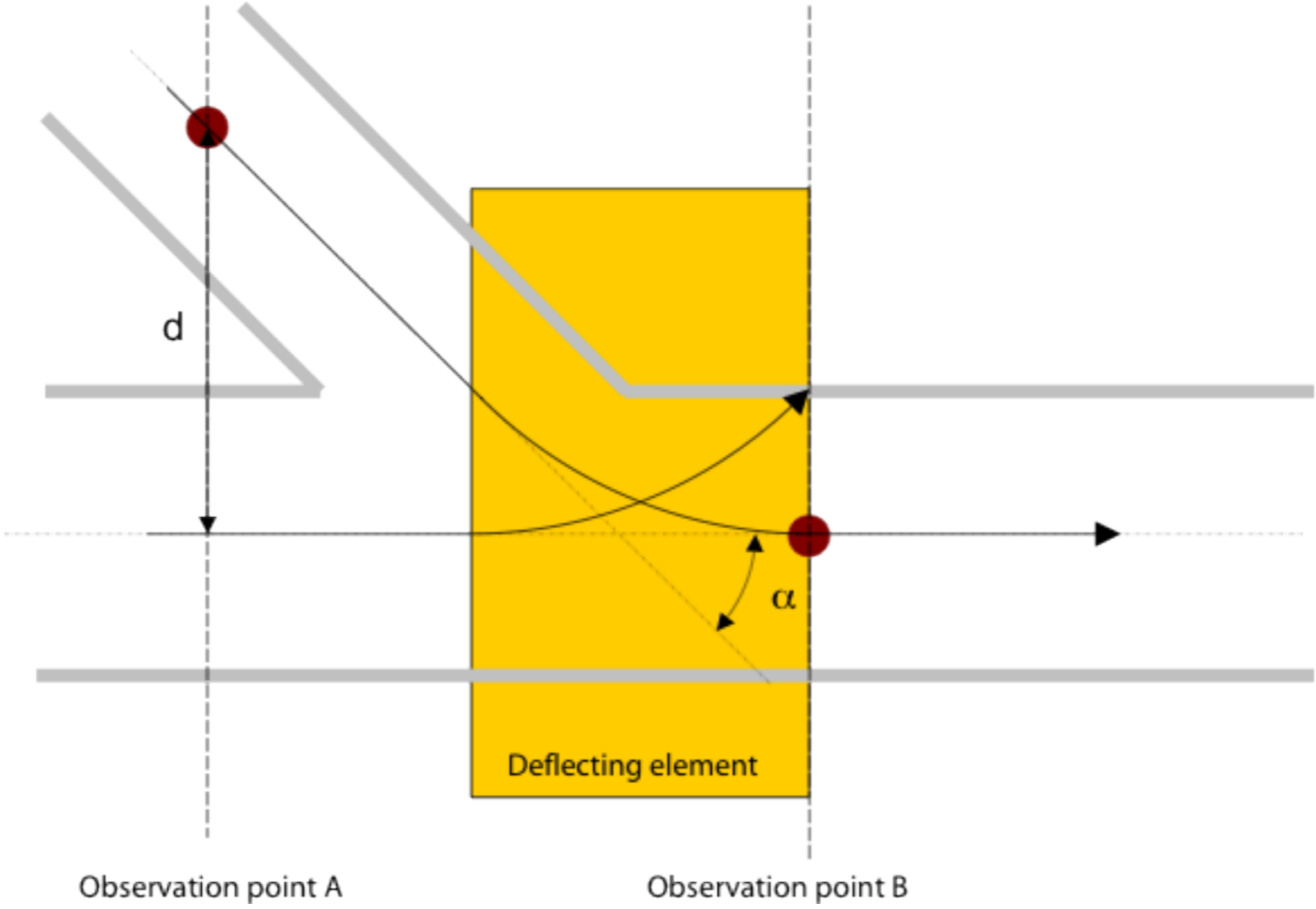

Injection, phase space

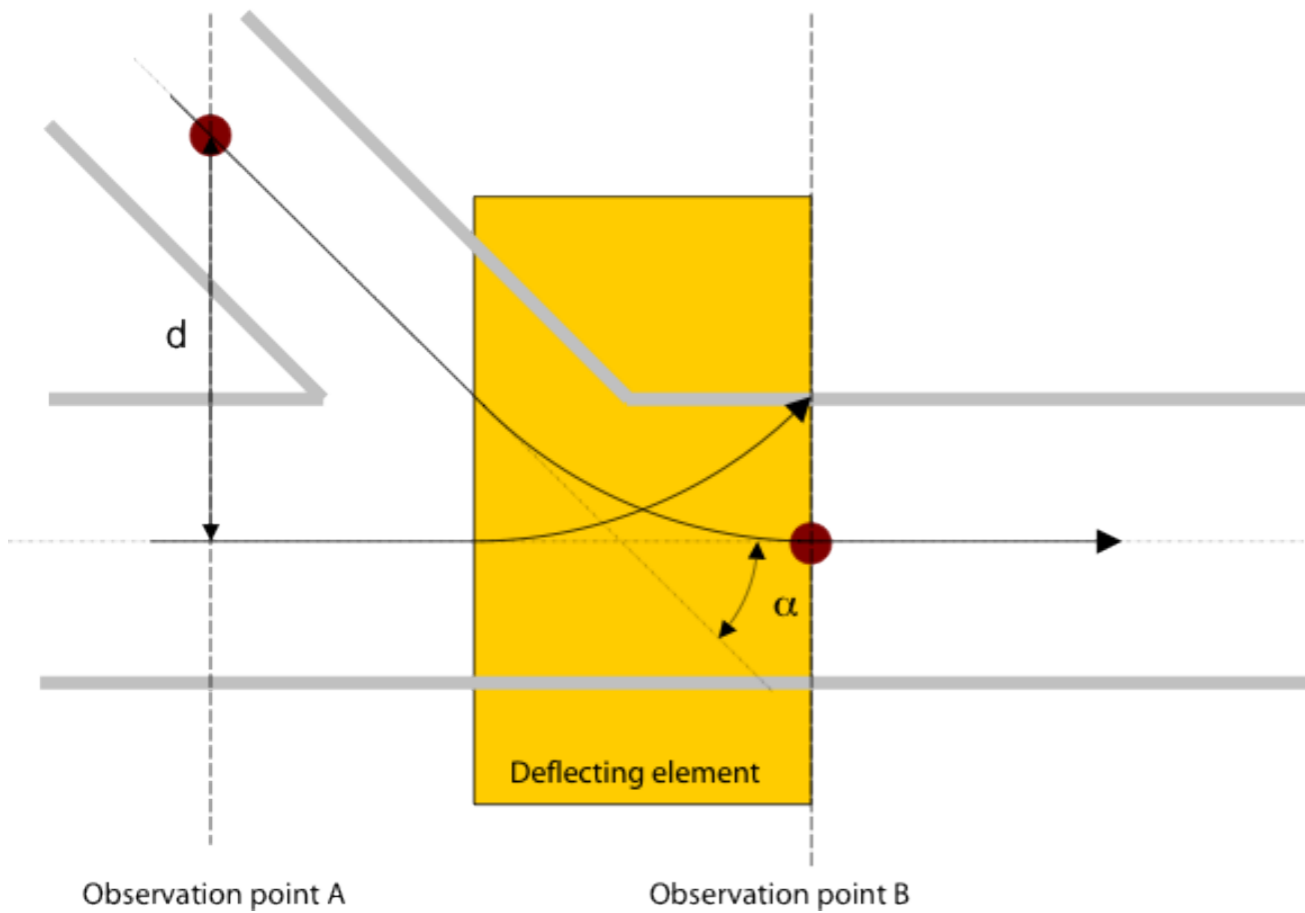

Real space

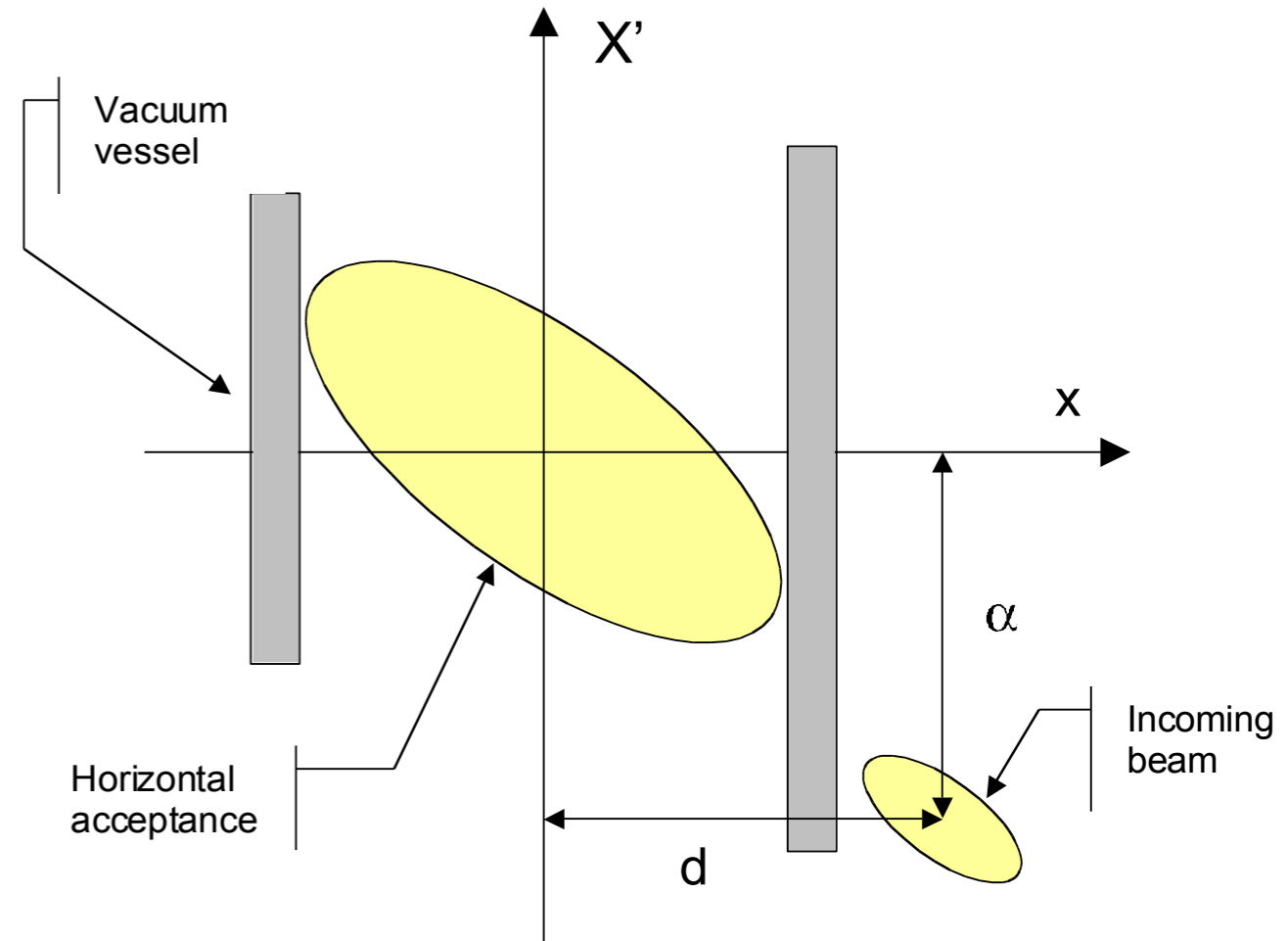

Phase space
(point A)

Magnetic elements

Kicker

Fast dipoles with homogenous field over the vacuum chamber cross section.

Pulsed magnets with fast raising and falling times required to control the timing of interaction with the beam.

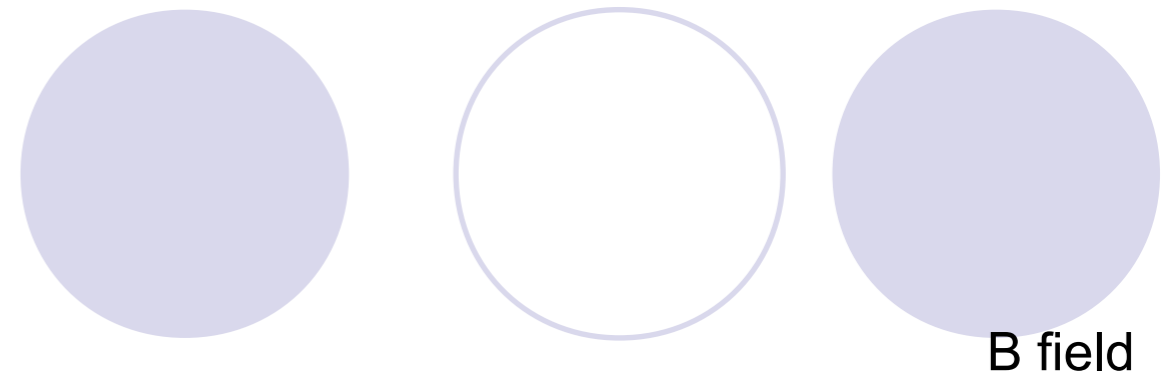

Septum

Dipole on one side of the blade, no field on the other side. The blade is screening the field but is an obstacle to the stored beam.

Usually pulsed magnets because high peak fields are needed.

Injection



- There are basically two different injection processes:
 - The **single turn** injection process, where one single pulse is injected into an accelerator (booster...) before being accelerated and then extracted.
 - The **multi-turn** injection process, where one or several pulses are injected over several turns or accumulated one after the other. This essentially concerns the storage rings but also some accelerators.
- In the majority of cases, injection is performed in the horizontal plane.

Single turn injection (on-axis injection)

- The beam is injected onto a central orbit using electromagnetic elements (usually a **septum magnet** and a **kicker**)
- As the injected beam is put on the ring axis at the exit of the kicker, this is also called “**on-axis injection**”.
- The septum and the kicker should not act on the injected beam when it comes back after one turn, otherwise it would be thrown out of the acceptance of the accelerator. This requires that:
 - The stray field of the septum unit is at an acceptable level,
 - The kicker field is reduced to zero in a time that is short compared to the revolution period.

On-axis injection

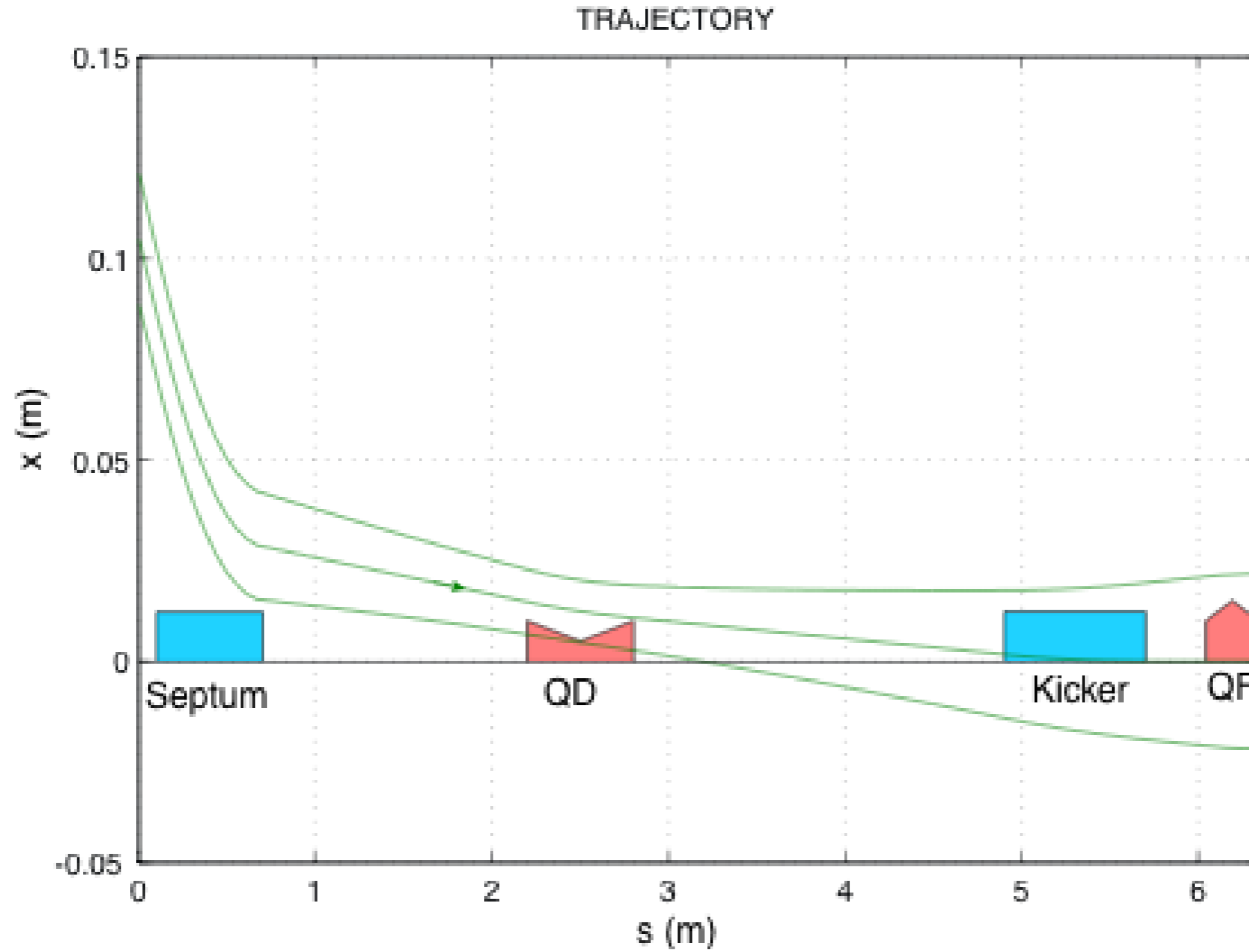
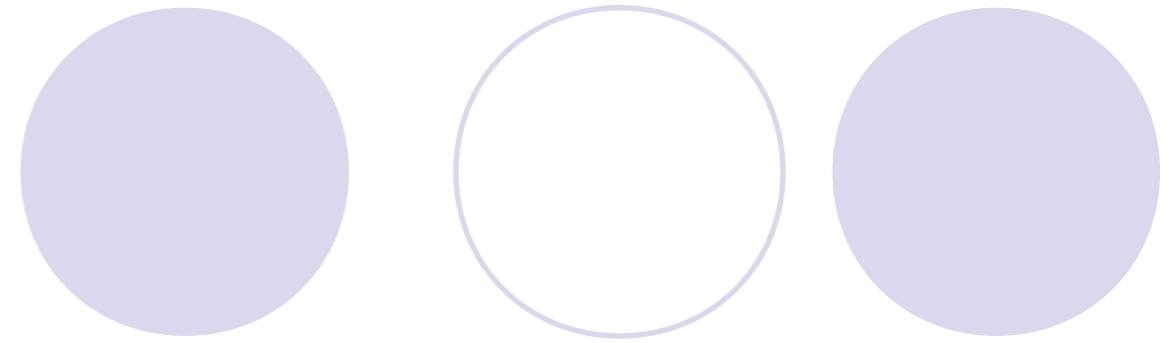

Injection/Extraction

On-axis injection

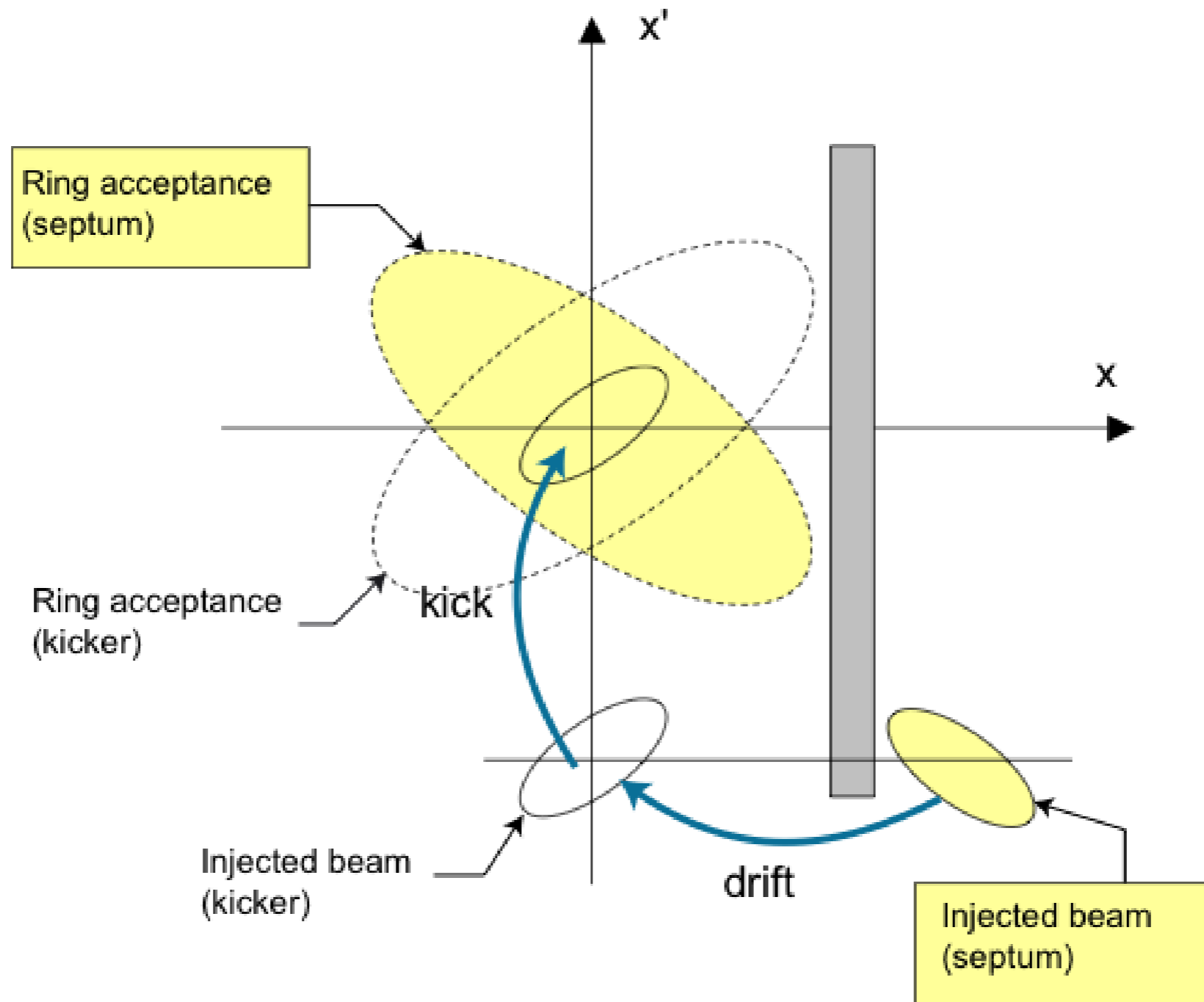

Injection/Extraction

Matching



- The first requirement for the injected beam is that it is matched at the entry point to the ring. This means that, at the exit of the septum unit, the betatron and dispersion functions

$$\beta_x, \alpha_x, \beta_y, \alpha_y, D_x, D'_x, D_y, D'_y$$

must be identical with the machine lattice parameters at that point.

- This is primordial when the emittance of the injected beam is comparable to the acceptance of the ring.
- This matching is performed using the dipoles and quadrupoles of the upstream transfer line.

Example of bad matching

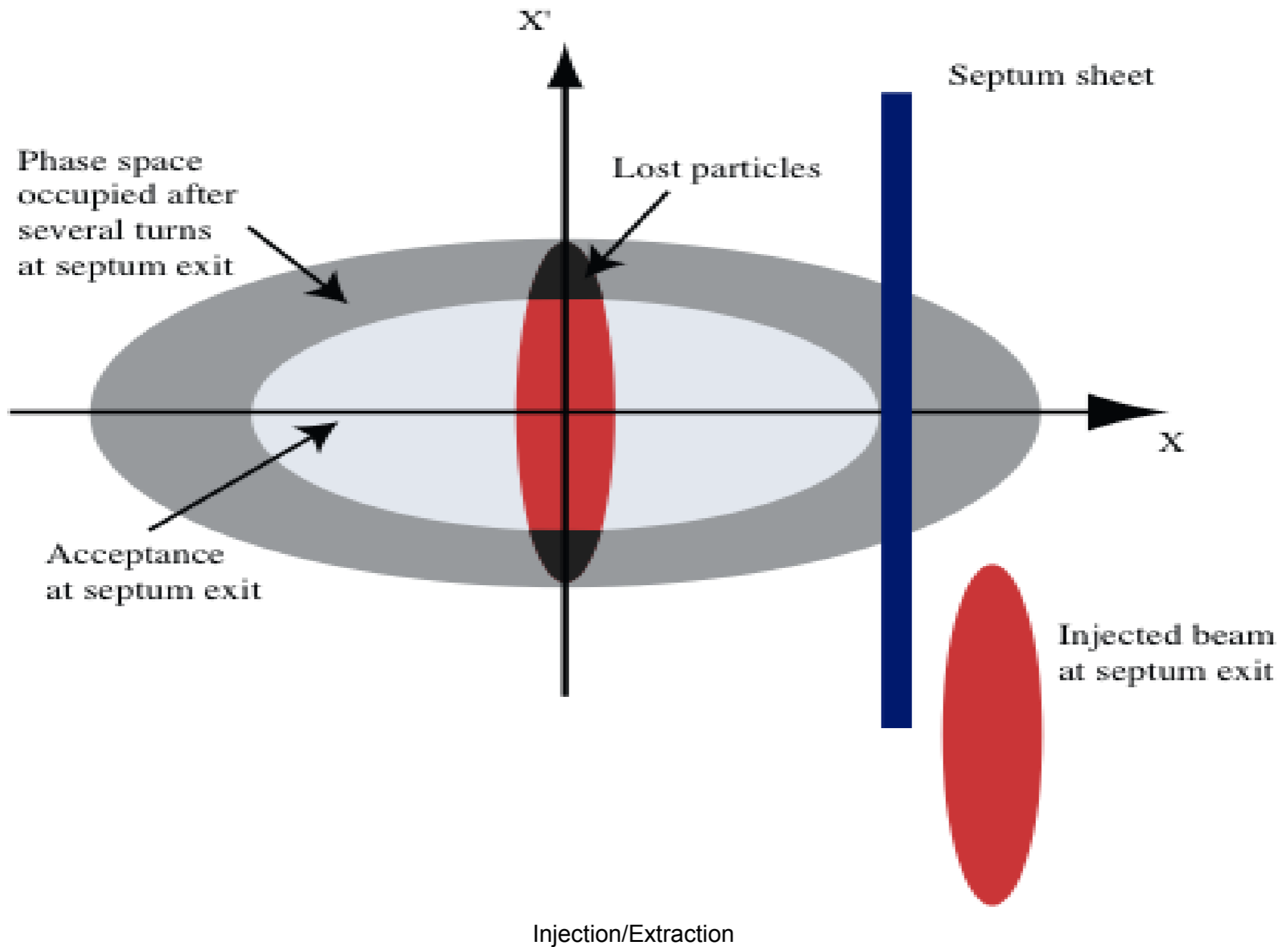

Injection parameters: septum position

Usually the injection septum is the main limitation of the horizontal acceptance (Minimum kick angle to be provided by the fast kicker \Rightarrow septum as close as possible to the machine axis). The center of the injected beam is at a position X_s :

- W_{acc} the half width of the acceptance or distance between machine axis and septum blade.
- ΔX_{co} margin for orbit errors or defects of the septum blade.
- W_{inj} the half width of the injected beam.
- W_{blade} the septum blade width as given by technical drawings.

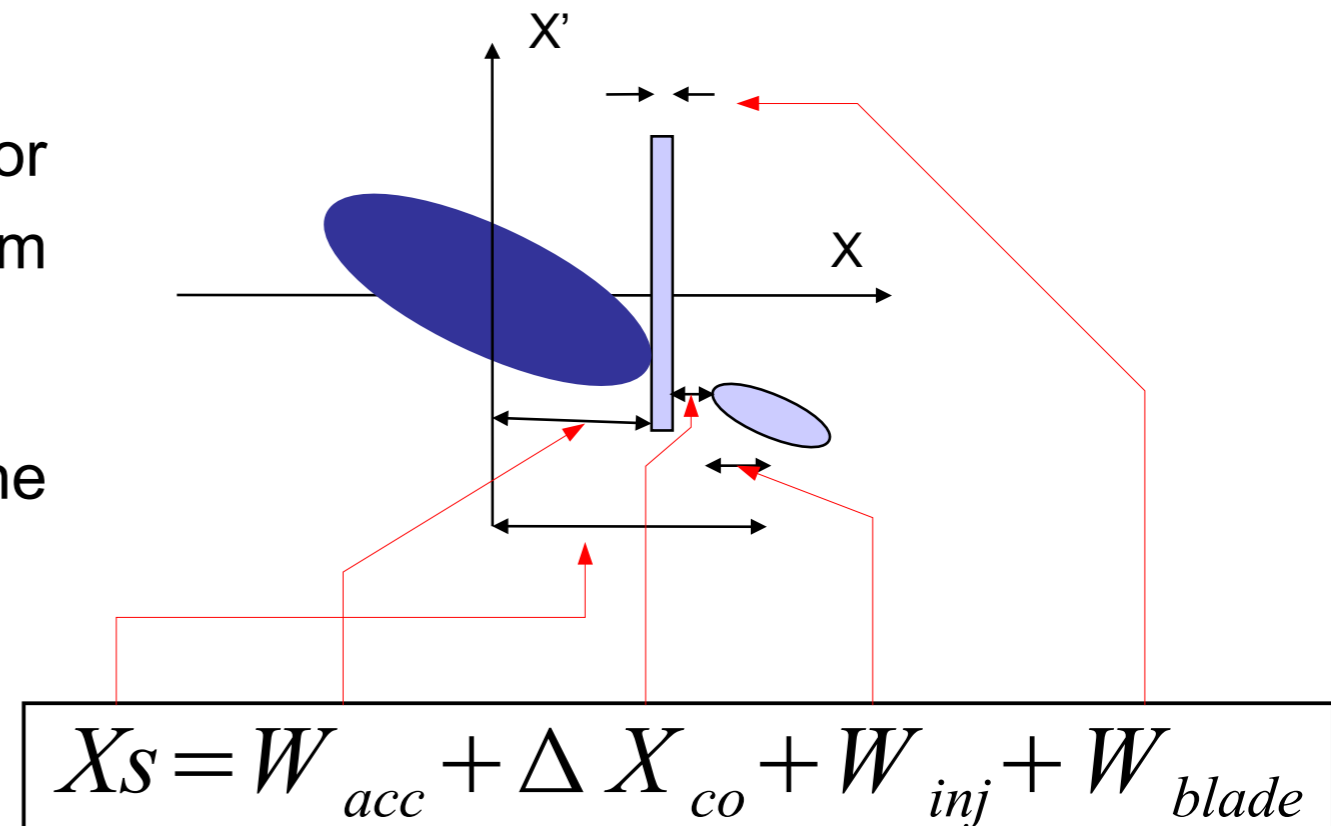

Injection parameters

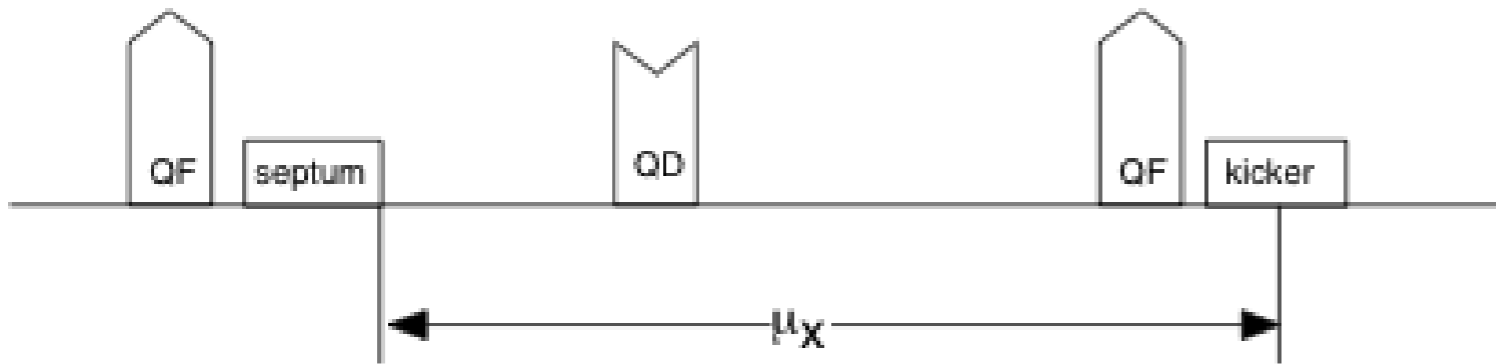

If μ is the betatron phase advance between the exit of the septum and the kicker, the transfer from septum to kicker, in normalised coordinates, is written as:

$$(\alpha_x x + \beta_x x') / \sqrt{\beta_x}$$

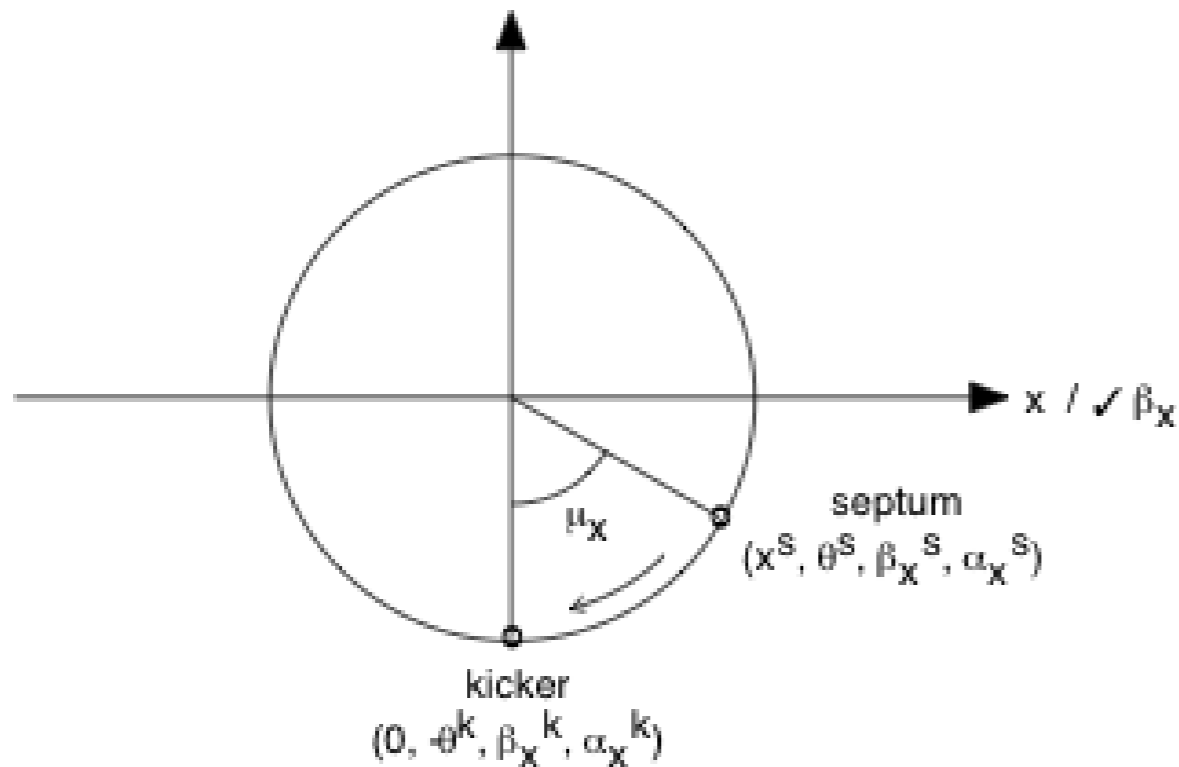

$$\begin{pmatrix} X_K \\ X'_K \end{pmatrix} = \begin{pmatrix} \cos \mu & \sin \mu \\ -\sin \mu & \cos \mu \end{pmatrix} \cdot \begin{pmatrix} X_S \\ X'_S \end{pmatrix}$$

How can I minimise x' the kick to be given by the fast kicker ?

Injection parameters: kick angles

The injected beam must reach the ring axis at the place of the kicker:

$$X_k = \cos \mu X_s + \sin \mu X'_s = 0$$

Knowing the beam position X_s at the exit of the septum, this gives conditions for the angles at septum and kicker locations:

$$X'_s = -\frac{X_s \cos \mu}{\sin \mu} \quad X'_k = -\frac{X_s}{\sin \mu}$$

Going back to normal coordinates, we get the beam angle at the exit of the septum:

$$x'_s = -\frac{(\alpha_s + \cot \mu)x_s}{\beta_s}$$

The kick angle that the kicker must provide to the beam to bring it back to the ring orbit is:

$$\theta_k = -x'_k = \frac{x_s}{\sin \mu \sqrt{\beta_k \beta_s}}$$

β_k, β_s : beta functions at the kicker and septum

Injection parameters: conclusions

$$x'_K = - \frac{x_S}{\sin \mu \sqrt{\beta_K \beta_S}}$$

- To minimise the angle to be provided by the kicker:
 - Large beta values at the septum and kicker locations
 - Phase advance μ_x close to $\pi/2$.
- This is the case in a standard FODO lattice where the septum and kicker are located in the vicinity of focusing quadrupoles at a distance of one cell.

Off-axis injection

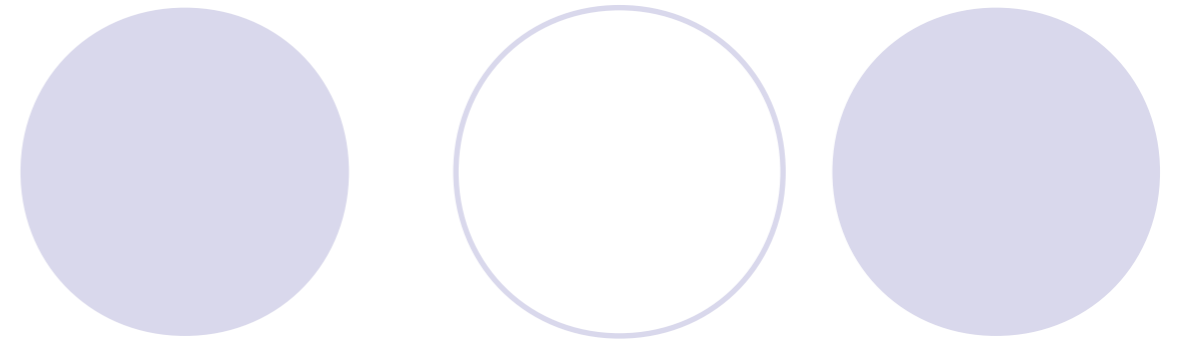

- The on-axis injection considered so far is only applicable if:
 - the phase space, into which the delivered beam is to be injected, is free of particles (otherwise the already circulating particles would be thrown out of the accelerator acceptance by the kicker firing),
 - the beam pulse to be injected is shorter than the revolution time of the accelerator.
- Off-axis injection is necessary when the injected pulse (or train of pulses) is longer than the revolution time, or in the event of **accumulation** into a storage ring.
- A different technique is employed for electrons (and positrons) than for protons or heavier particles. We first consider the case of a long beam pulse to be injected (multi-turn injection of protons) and then the accumulation of an electron beam in a storage ring.

Multi-turn injection

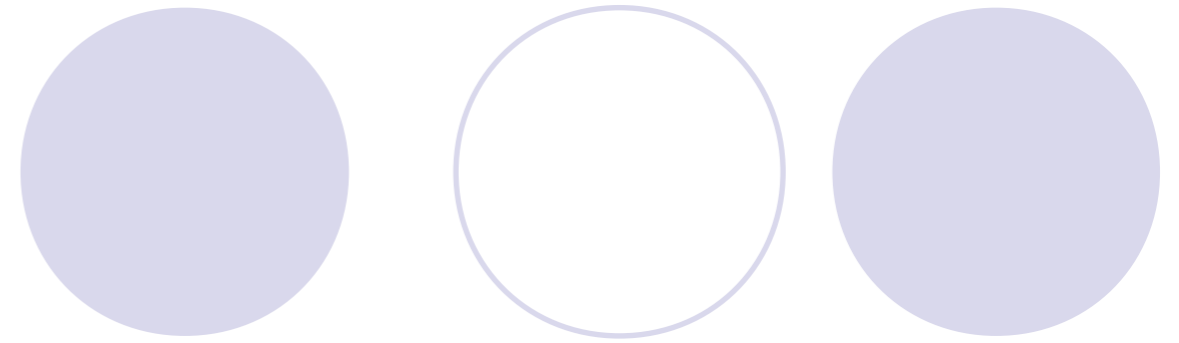

Conventional multi-turn injection uses an input septum unit associated with a programmed **orbit bump** in the vicinity of the septum. Such localised beam bumps can be produced by two or more kicker magnets.

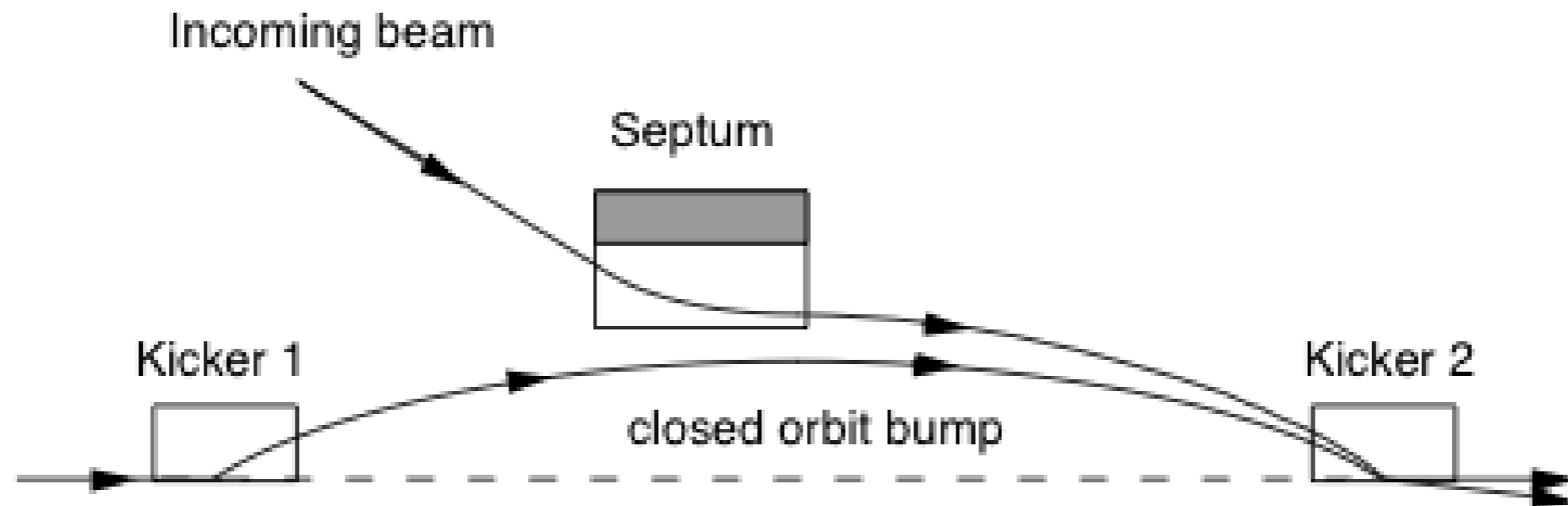

The role of the orbit bump is to **shift the horizontal transverse acceptance** of the ring towards the injected beam at the exit of the septum.

Multi-turn injection

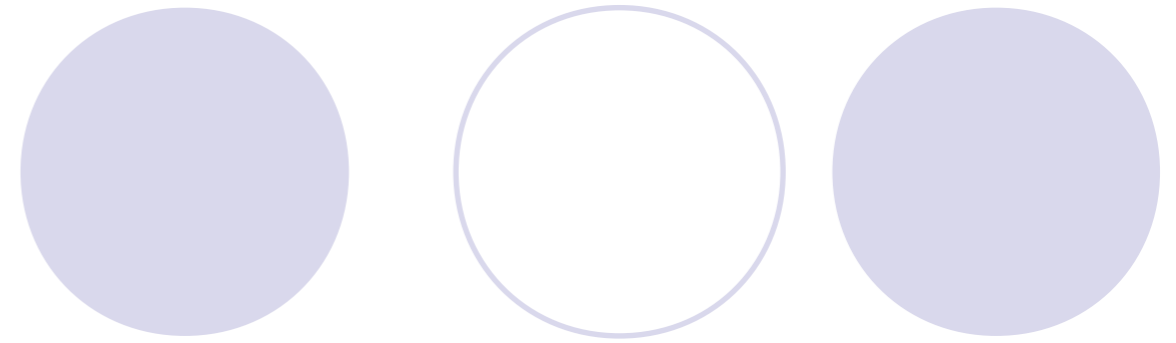

Let us study the limits for the accumulation process and first consider the dependance on the tune. In this following case the beam to be injected is injected “off axis” with a fractional tune of 0.25:

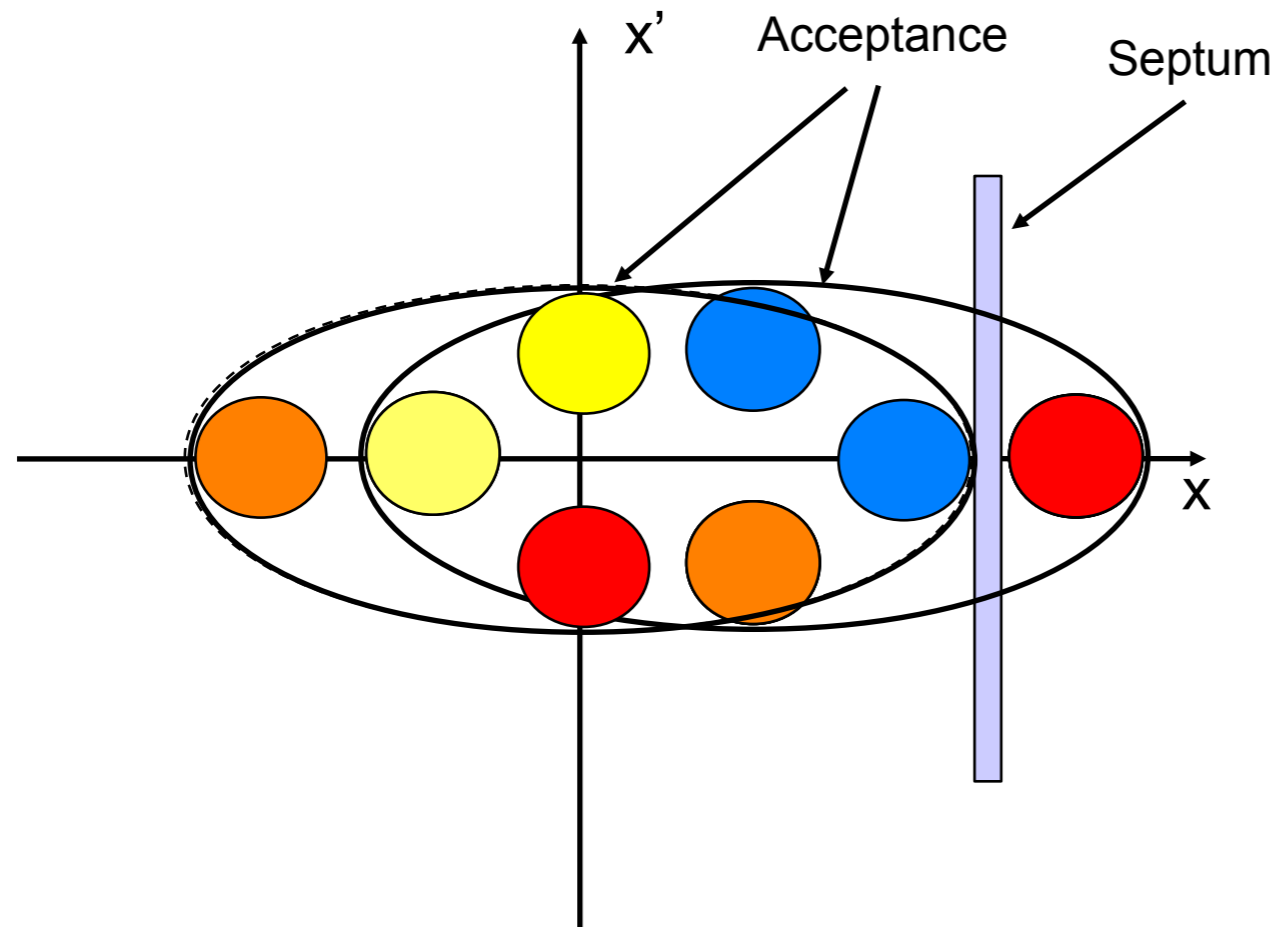

- Powering of the bump
- Injection of the first turn
- 2nd turn
- 3rd turn
- 4th turn
- Switching the bump off

In this case, the kicker bump has to be switched off, at the latest, before the injected beam completes the fourth turn.

Multi-turn injection

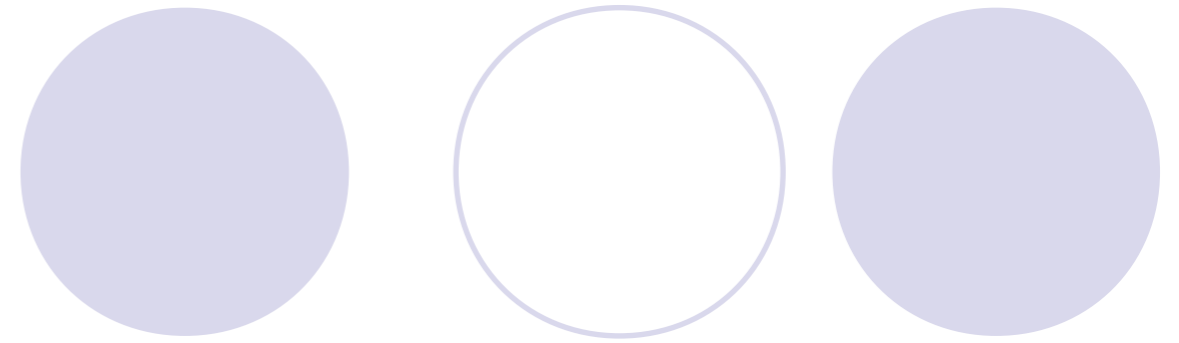

- In the case of the orbit bump making the closed orbit coincide with the center of the incoming beam in the septum magnet one would again find the case of an on-axis injection as considered before.
- The orbit bump can be made large enough to bring the first particles on axis, and then has to be reduced to enable stacking during the next four turns, and reduced again for the following four turns,.. until the full acceptance has been filled.

Multi-turn injection

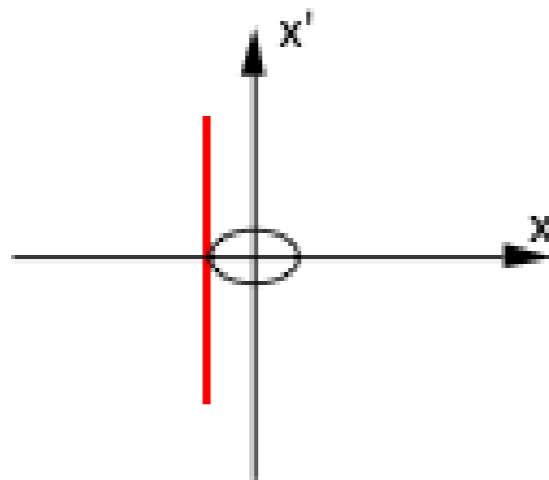

First turn : on axis

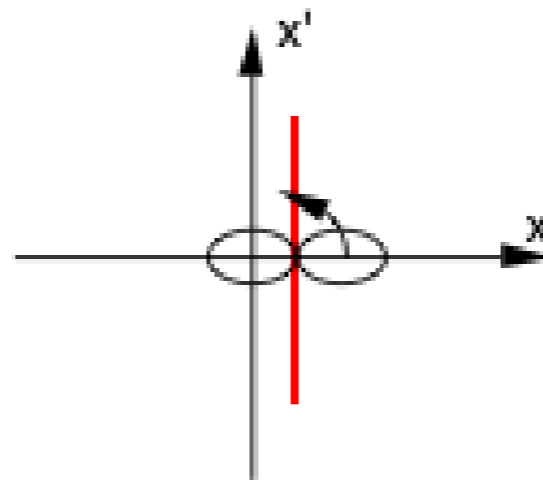

2nd turn : off axis
bump reduced

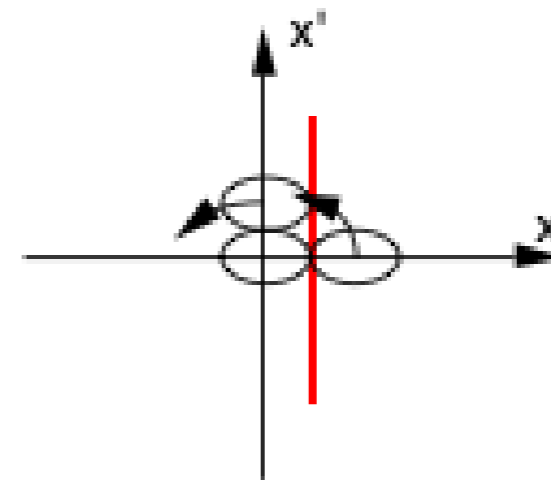

3rd turn : off axis

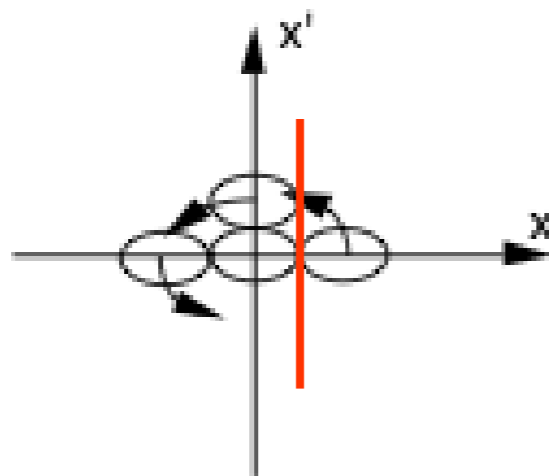

4th turn : off axis

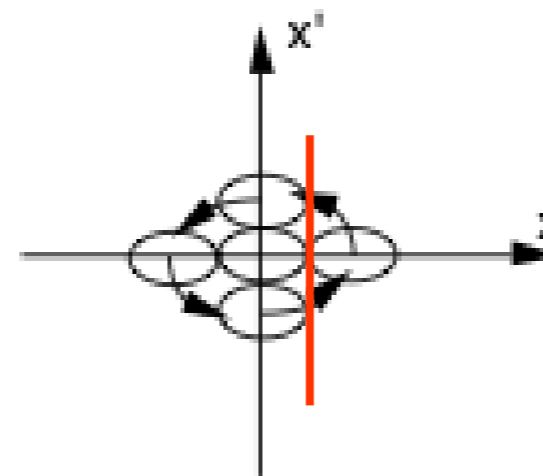

5th turn : off axis

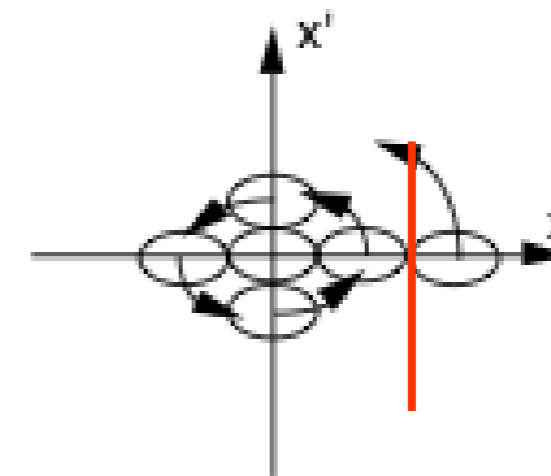

6th turn : off axis
bump reduced

Multi-turn injection



- There are other ways of preventing the stored beam from hitting the septum after one turn, such as using a large dispersion at the place of the septum and injecting the beam off-momentum.
- The injected beam will then start a betatron oscillation around the chromatic closed orbit. Then by either ramping the energy of the machine, or decelerating the injected beam, the chromatic closed orbit can be moved further from the septum.

Multi-turn injection

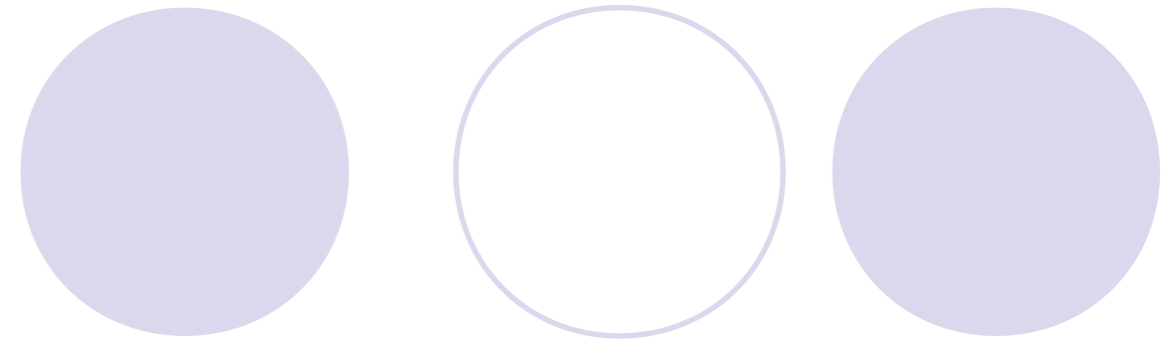

- Evolution of beam pulses which are injected at an energy δ_0 above the ring energy and then decelerated just after being injected.
 - ($\delta = E_{injbeam} - E_{ring}$)
- The advantage of such methods is a reduced horizontal emittance of the stored beam but with a larger energy spread.

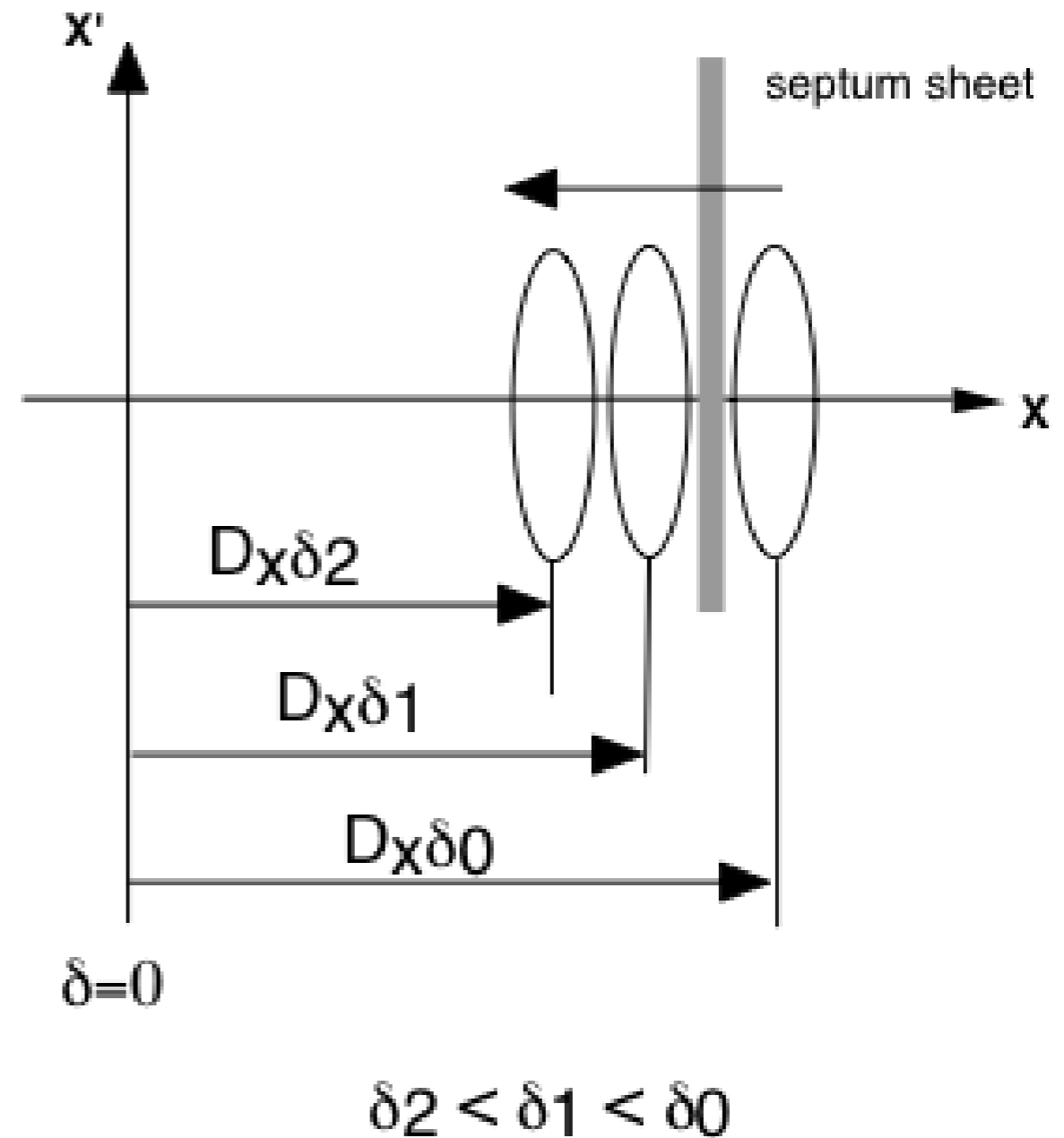

Multi-turn injection

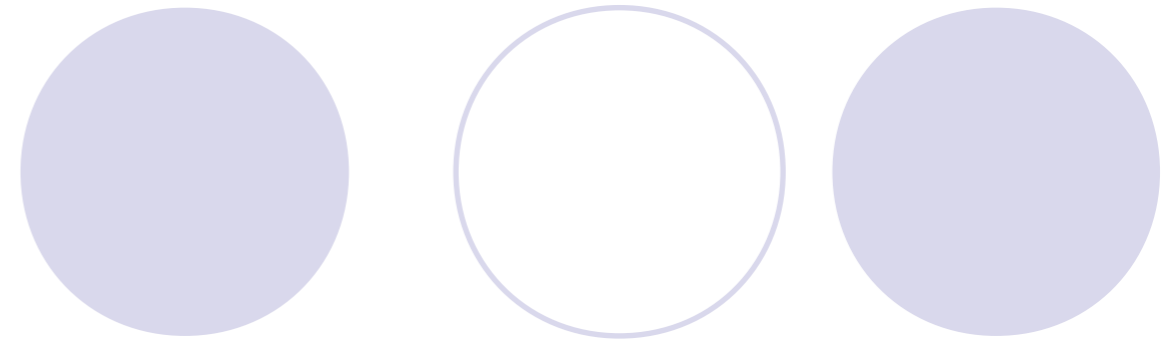

- In the case of multi-turn injection the injection process has to stop when the available phase space (acceptance) is fully filled with “stacks” of particles. If one would try to inject into a phase space area that is already filled with particles, these already stacked particles would get lost.
- In the case of a proton storage ring the density of the beam to be injected and the available phase space defines the maximum stored current.

- There is some emittance dilution essentially due to the transverse space charge effects. They induce non-negligible tune shifts and non-linear forces which result in the loss of particles as the machine aperture intercepts the halo that develops.
- With the increasing intensity of the machines, the consequence of the beam losses has become increasingly significant and new injection schemes were investigated.

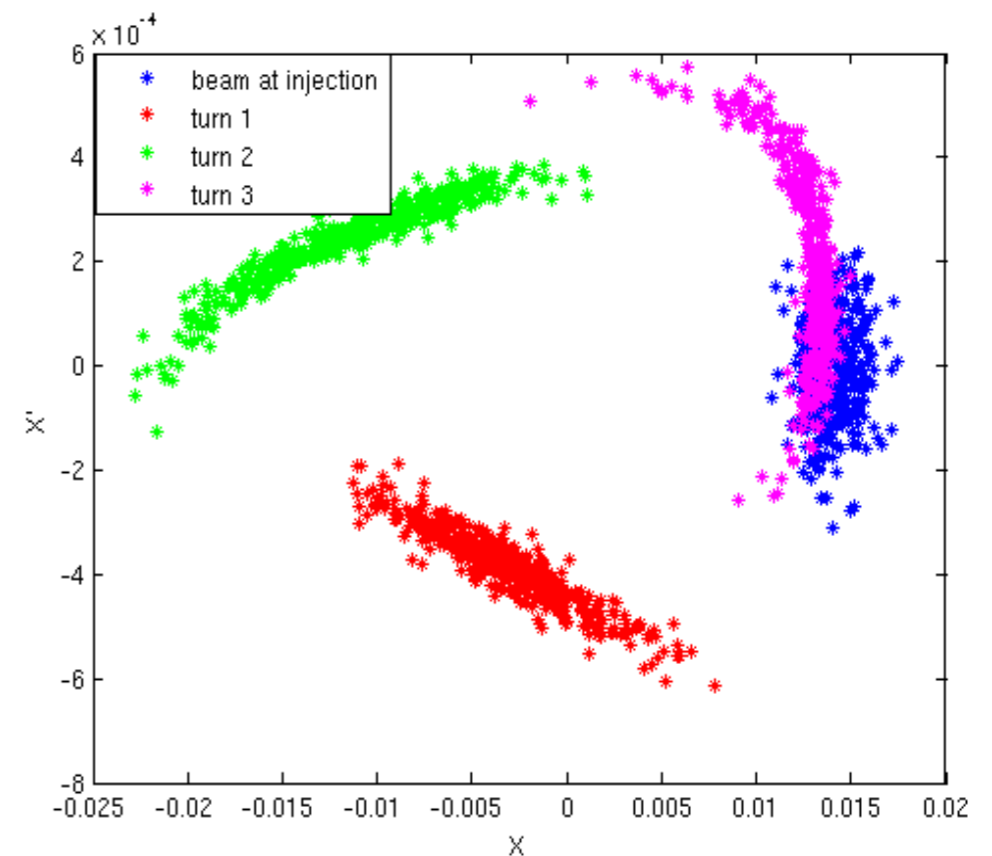

Emittance dilution of the ESRF injected beam.

Charge-exchange injection

- To overcome the saturation problem in the case of proton injection, and following the development of intense H^- ion sources, most of the high intensity proton rings now use the H^- charge exchange injection process.

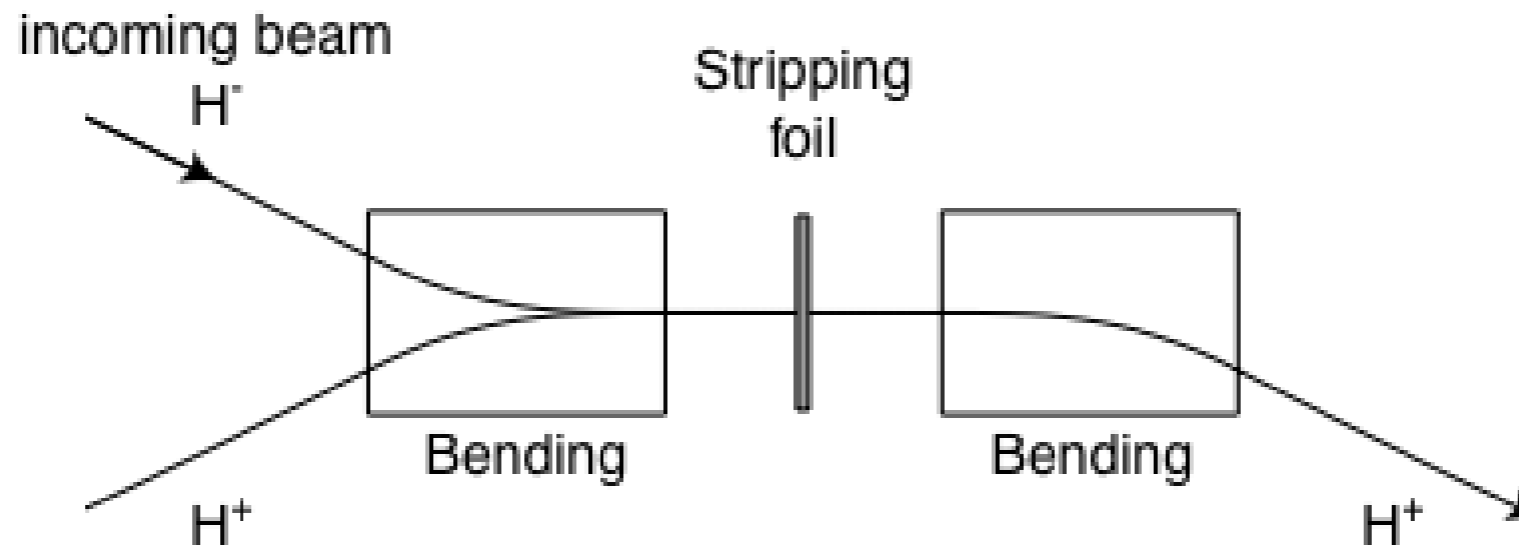

- The basic principle is to change the charge of the particle after it has passed the injector magnet. This is done by inserting a thin stripping foil which removes the two loosely bound electrons of the H^- . The foil thickness is chosen to give a high stripping efficiency (98%) without introducing appreciable scattering and momentum spread (this depends on the injection energy).

Charge-exchange injection

- The advantage of this process is that there is no need to shift the transverse acceptance outside the physical aperture: Injection can be performed during a **large number of turns with superposition in phase space**.
- An orbit bump is still useful to avoid crossing the stripping foil after injection is finished.
- This method enables to fill the transverse acceptance with a uniform transverse density distribution to minimise the space charge forces.
- Such a uniform filling may be achieved by applying a **“painting”** of the acceptance: a vertical steering of the H⁻ in the injection line and a variation of the horizontal orbit bump in the vicinity of the stripping foil are applied simultaneously to fill the acceptance.

Electron accumulation

- Electrons are at a sufficient energy for space-charge forces to be insignificant,
- Electron circular machines are submitted to the Synchrotron **radiation damping**: after a few damping times the emittance is only governed by the radiation equilibrium.
- A single turn is first injected off-axis. Radiation damping effects in the ring then lead to the damping of the horizontal betatron oscillations of the injected particles. The injection process may then be repeated.
- The injection is not limiting the maximum intensity which can be stored on electron storage rings.

Electron accumulation

- After a few damping times, the injected electrons occupy the center of the density distribution and have freed the phase space at the outer areas of the acceptance. The beam bump is then energised again and a second beam pulse is injected.
- The sequence is repeated until a sufficient circulating intensity is obtained.

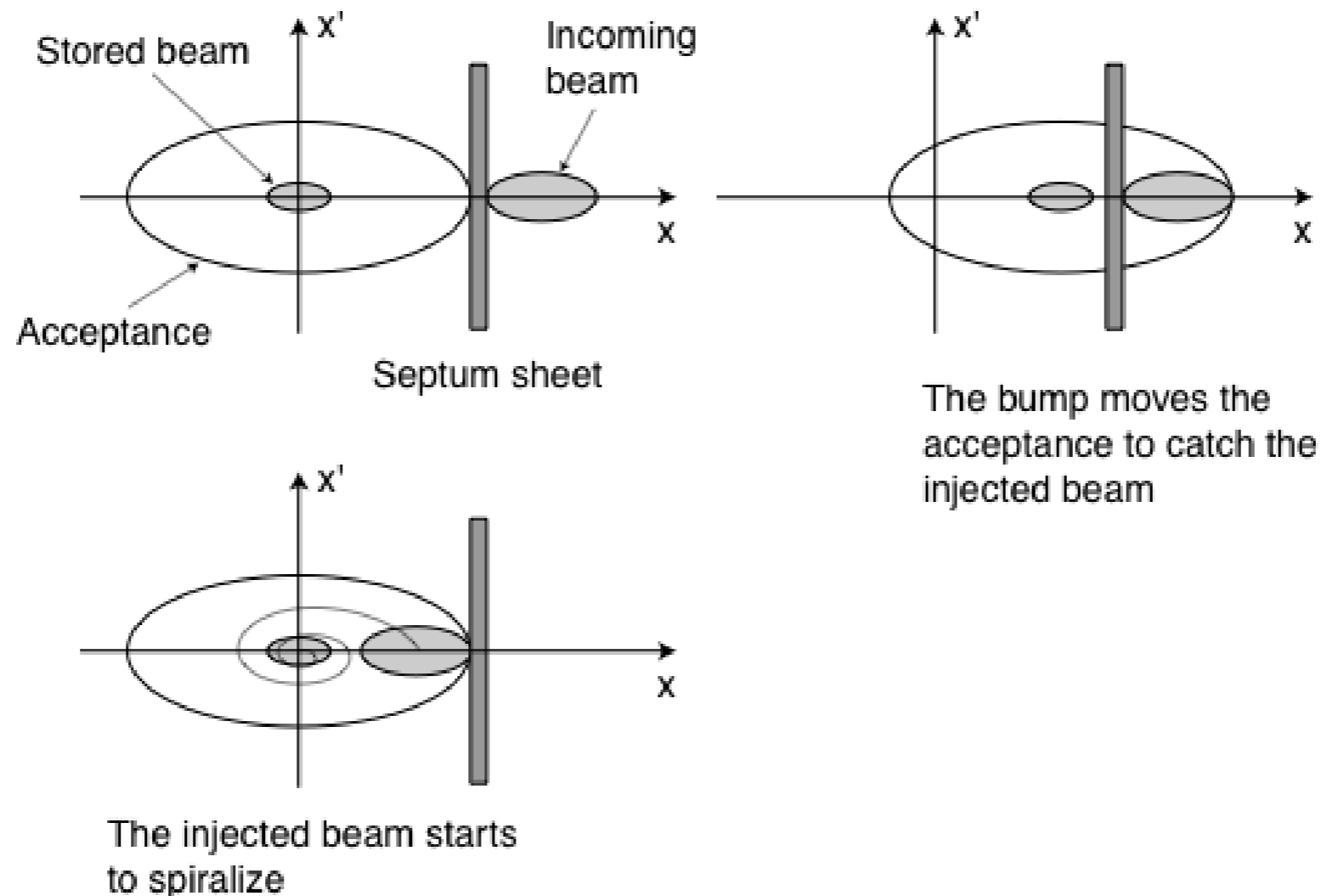

Electron accumulation

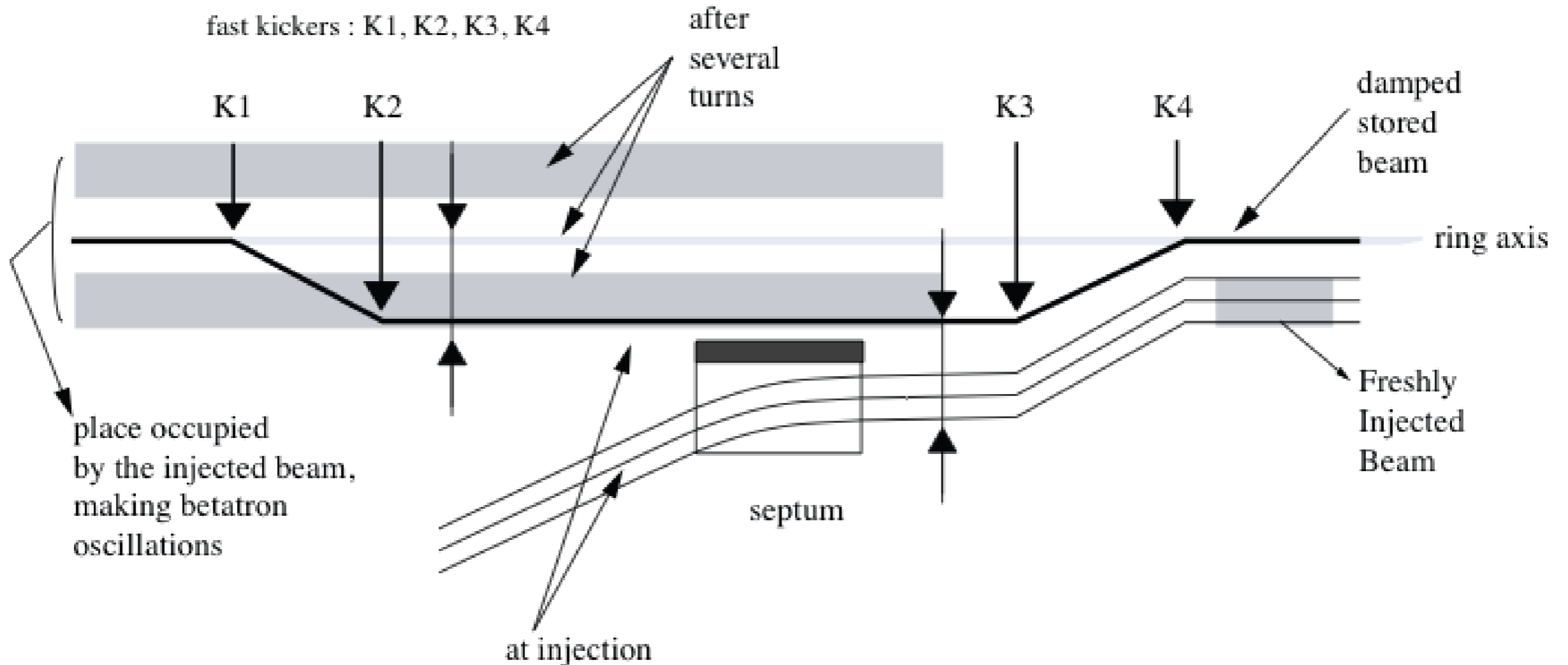

The beam after injection occupies the full chamber width up to the septum, then after a few damping times, it is reduced to the equilibrium size and the same process can be repeated again.

Example of innovative injection scheme: Single kicker injection

K. Harada, Y. Kobayashi, KEK
Photon factory

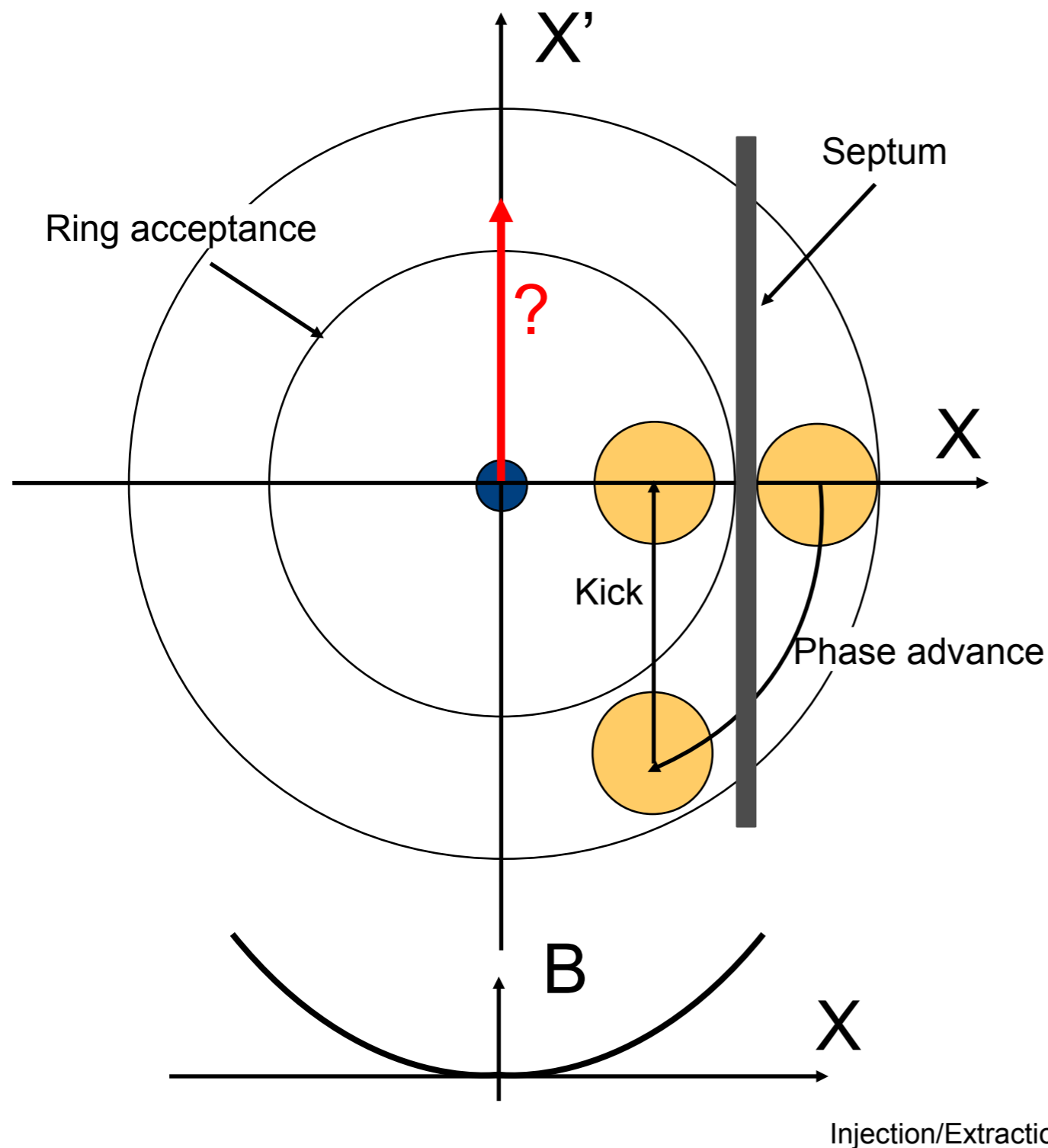

Injection

The beam is outside the acceptance

Drift along the circumference

The beam is still outside the acceptance

Kick

The injected beam enters the acceptance

The circulating beam is not perturbed by the non-linear field

Example of innovative injection scheme: Single kicker injection

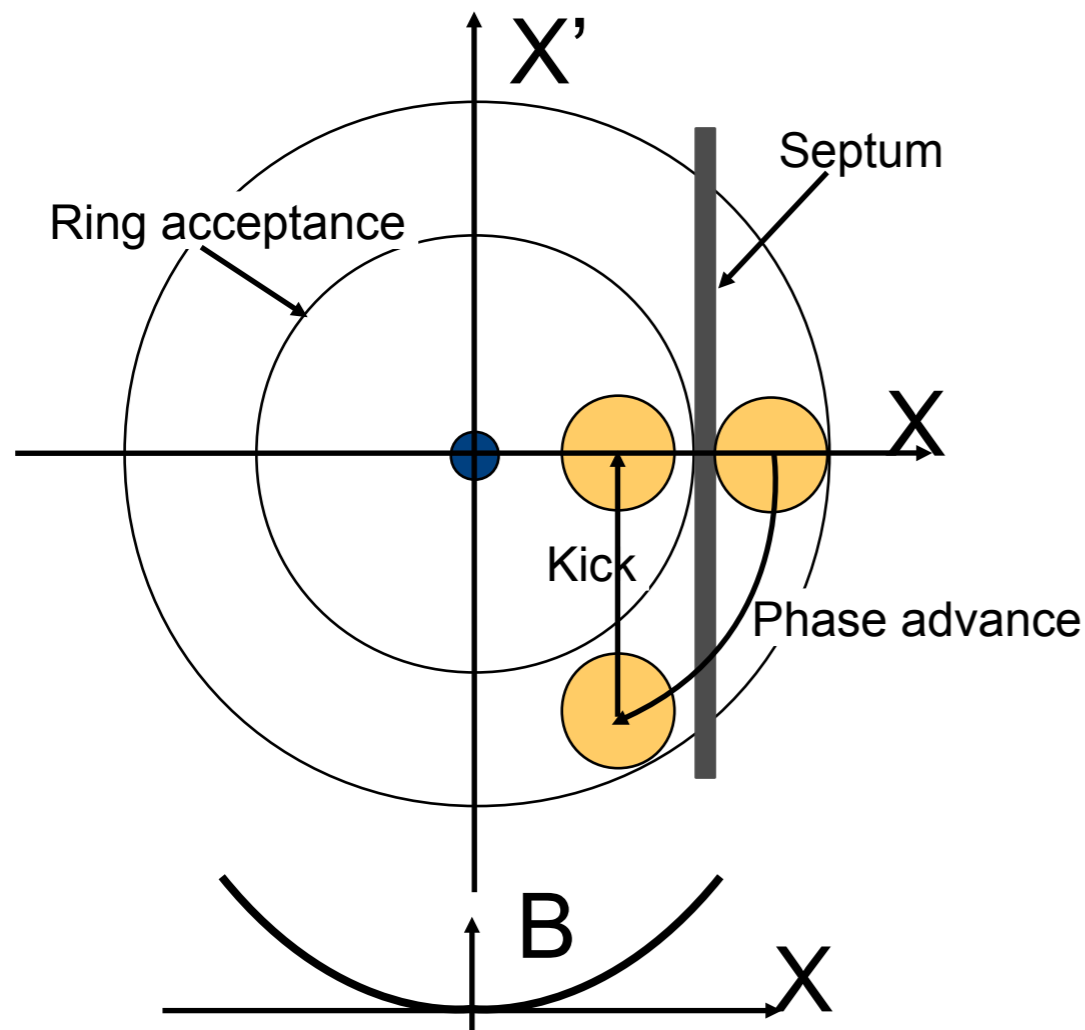

Advantages

Single kicker magnet instead of 3/4 kickers.
no perturbation on the circulating beam.

Difficulties

Magnet design : this kicker is able to provide a fast deflection in the mrad order at a given position separated from a zero field region by only a few mm.

Strong non linear field disturbs linear

Successful tests at BESSY in 2013.

Some new machines injection schemes are based on this concept.

RF capture



- The injected beam has also to be trapped in the **longitudinal acceptance** of the accelerator. Several cases are to be considered depending on whether the injected beam is already bunched or not, and when the RF system of the ring is turned on:
 - Bunched beam with RF on
 - Coasting beam with RF on
 - Injection without RF

Bunched beam with RF on

- The simplest case is when the frequency of the RF injector system is the same as the one of the ring. The phase between the two RF systems has to be adjusted correctly so that the injected bunches fall just inside the ring RF buckets.

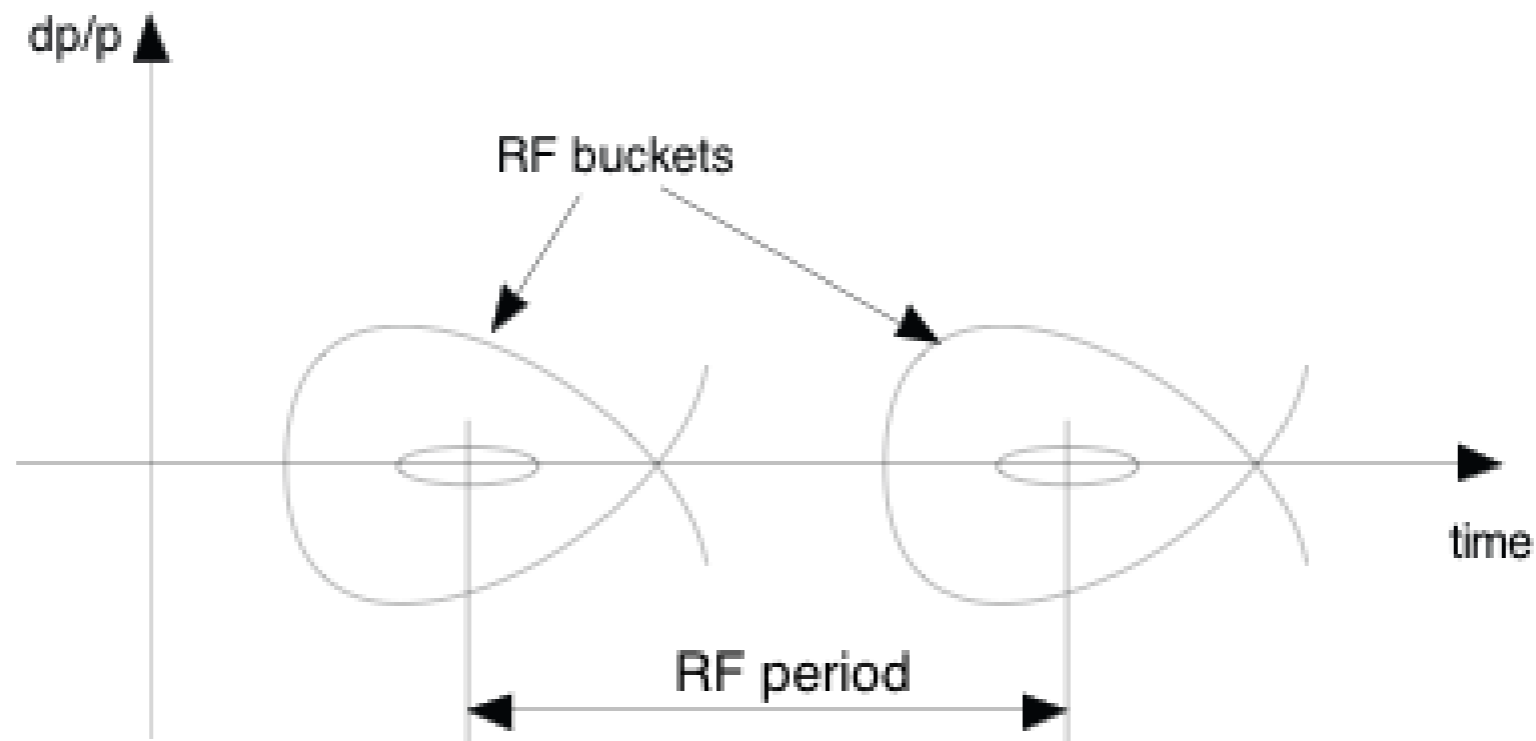

Coasting beam with RF on

- Only the particles that fall inside the RF buckets will be captured. The bucket size (RF voltage) has to be optimised in order to have the maximum phase acceptance while keeping the maximum energy deviation within the transverse energy acceptance of the machine.

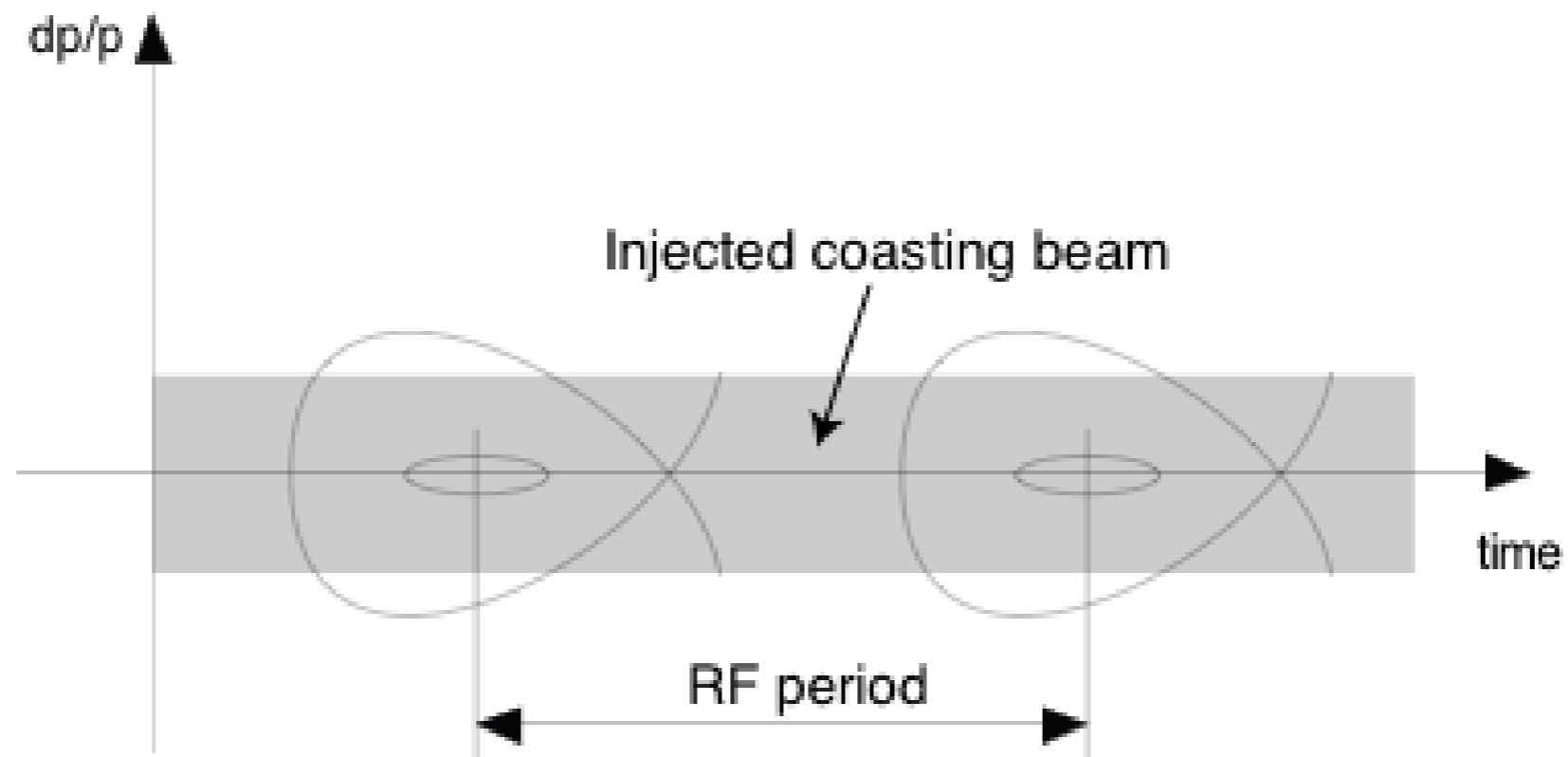

Injection without RF



- Once the injection process is completed, the RF is turned on progressively in order to bunch the beam (adiabatic capture).

Phase space matching in transfer line

- The last stage of a transfer line must enable the matching of the optical functions in the two transverse phase spaces: This means, controlling at the exit of the septum unit, the following betatron and dispersion functions
 - $\beta_x, \alpha_x, \beta_y, \alpha_y, D_x, D'_x, D_y, D'_y$
- These are **8 constraints** which require **8 quadrupoles**. In most of the cases, the injector and the ring are in the same horizontal plane, which means that in the absence of vertical bending magnets, there is no vertical dispersion: $D_y = D'_y = 0$.
- Then only 6 quadrupoles are required.

Phase space matching in transfer line

- As the septum provides a horizontal bending angle, this has to be taken into account for the matching of D_x and D'_x .
- If there are several bending magnets along the transfer line it can be interesting to separate the roles of the quadrupoles which match the beta functions by placing them in a dispersion-free straight section.
- The steering in the horizontal plane is generally made by fine tuning of the injection magnets, whereas two steerer magnets are required at the end of the line to adjust the vertical beam angle and position at the injection point.

Phase space matching in transfer line

Horizontal matching for of-axis injection is more complex:

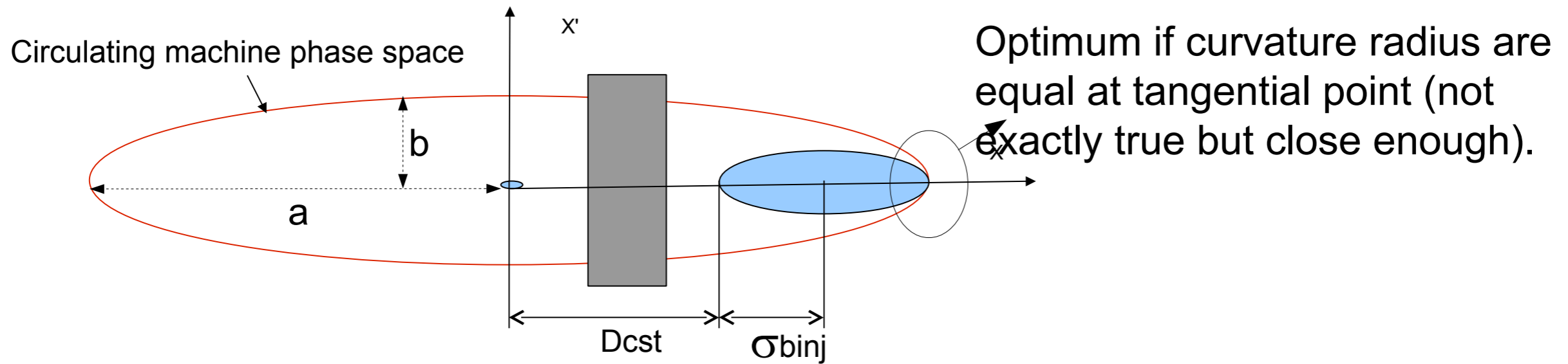

Curvature radius of an ellipse on it's principal axe

$$R_c = \frac{b^2}{a}$$

Red ellipse (acceptance):

$$a = \sqrt{(Ac \times \beta_{sr})} = d_{cst} + 2 \times \sigma_{binj}$$

$$b = \sqrt{\left(\frac{Ac}{\beta_{sr}}\right)}$$

Blue ellipse (injected beam)

$$a = \sigma_{binj}$$

$$b = \frac{\sigma_{binj}}{\beta_{binj}}$$

Phase space matching in transfer line

Horizontal matching for of-axis injection is more complex:

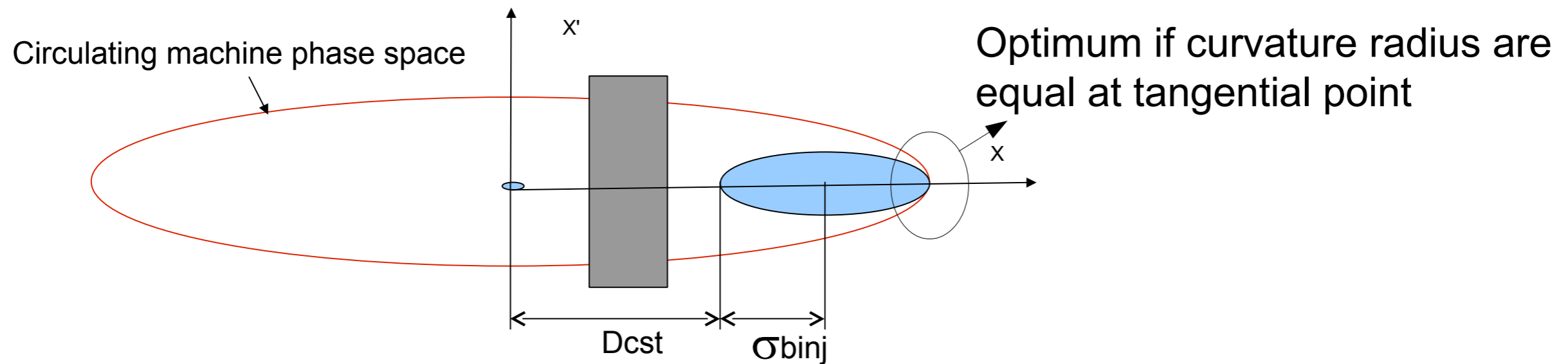

Optimum beta of injected beam as a function of circulating beam beta function at injection

$$\beta_{inj}^{-2} = \left(\frac{d_{cst}}{\sigma_{binj}} + 2 \right) \times \beta_{sr}^{-2}$$

Calculation assumes a linear machine whereas injection takes place at the edge of acceptance where phase space is usually distorted by non-linearities.

For derivation of the exact optimum see: "SLS booster to ring transfer optics for optimum injection efficiency" by A. Streun

Phase space matching in transfer line

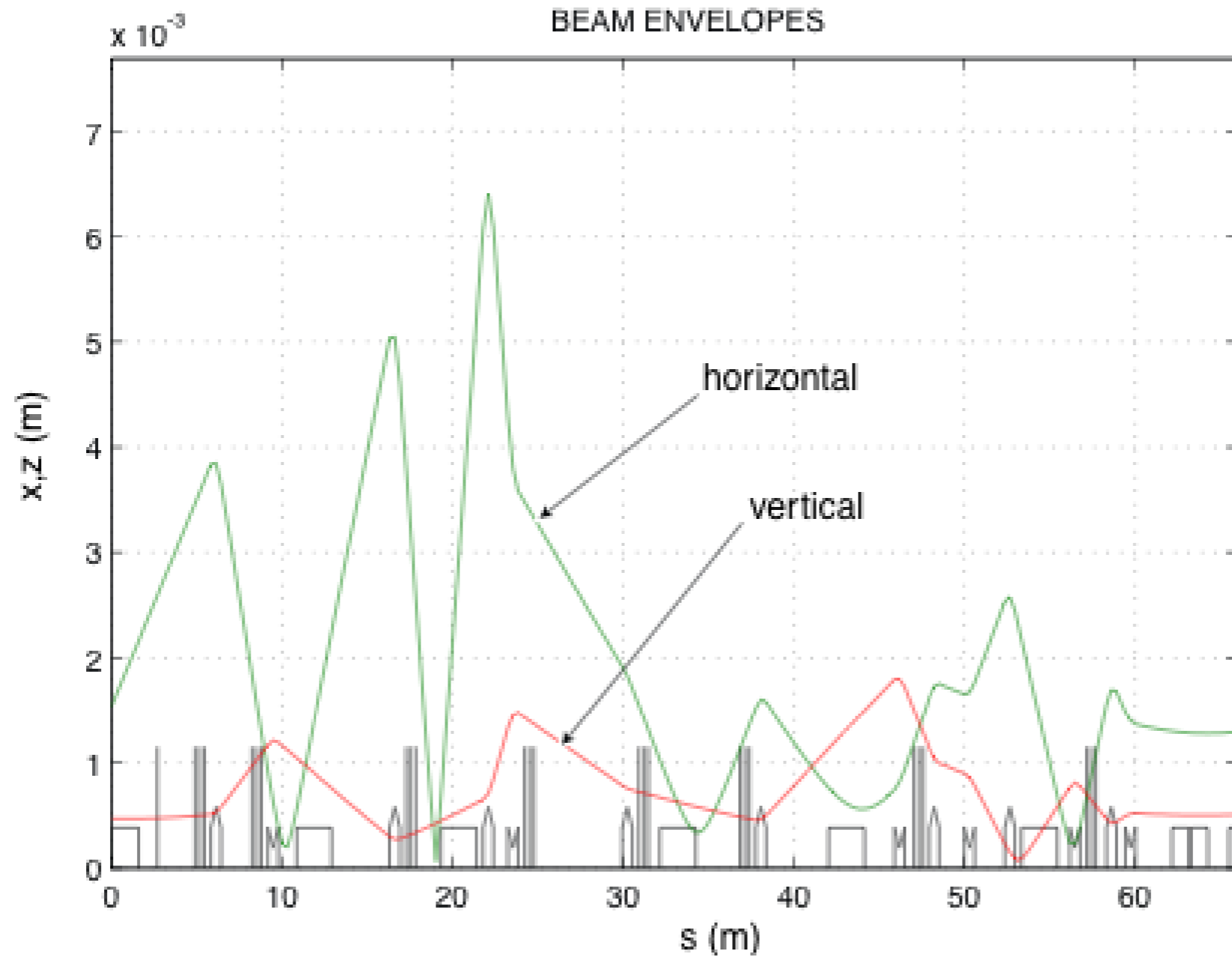

Beam envelopes along the ESRF Booster to Storage ring transfer line

Injection/Extraction

Topping-up

- For Synchrotron Radiation sources, injection into the storage ring can take place in time intervals comparable to the lifetime T_0 of the storage ring beam (e.g. injection at each T_0 , when the stored beam has lost about 40% of its initial charge) or in time intervals which are short compared to the lifetime (e.g. each $T_0 / 1000$, when the stored beam is still almost at its initial charge). The latter case is called topping up mode.

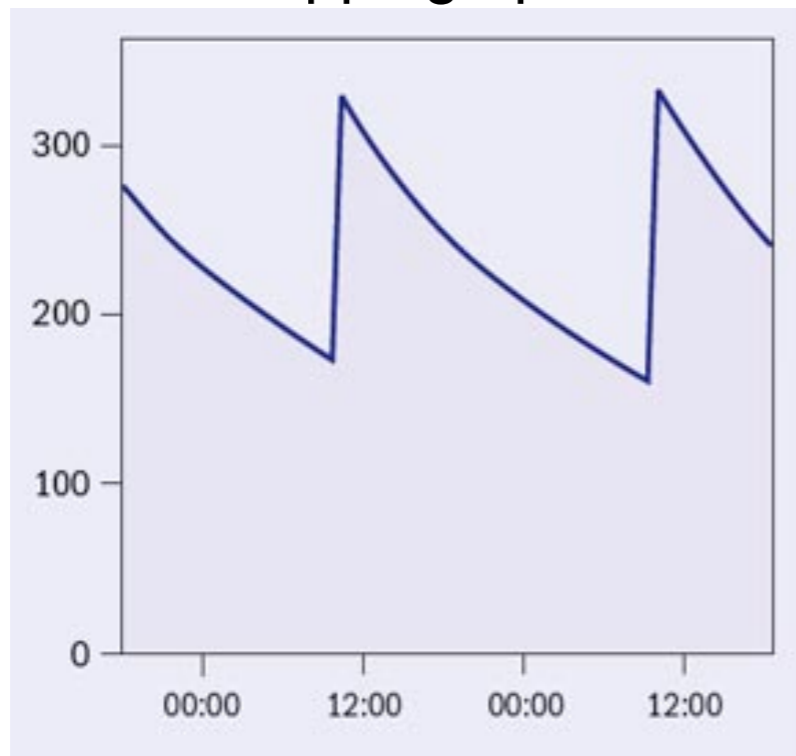

Normal mode: Injection every 12 hours

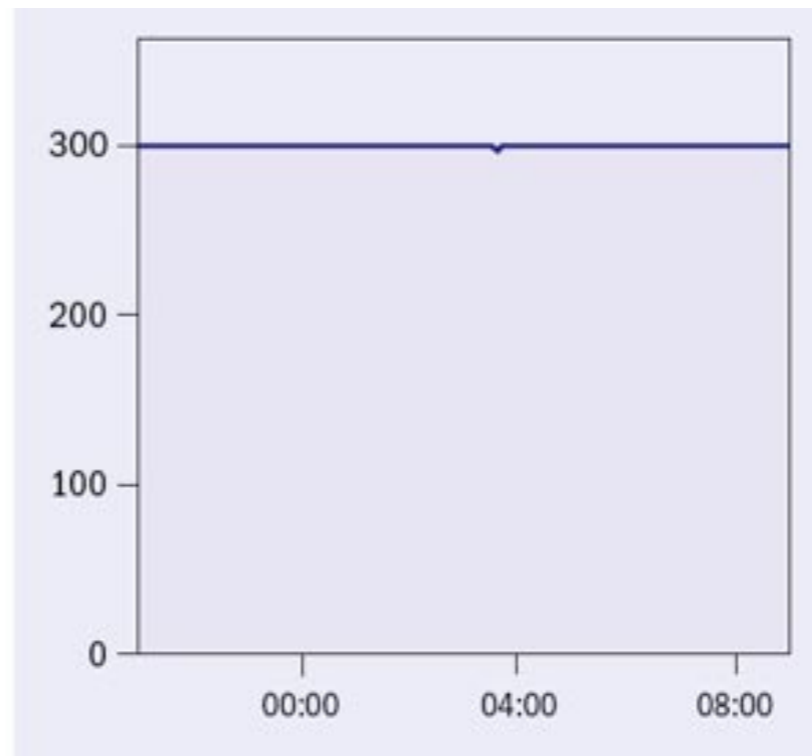

Top-up: Injection every 6 minutes
current variations are below 1%

Top up at ELLETRA

Topping-up



- **The normal injection mode has the advantage that:**
- The decay function over time of the stored current is smooth for many hours.
- The injection system has to be switched on only for short periods during the lifetime T_0 of the stored beam. This saves operation costs and avoids any electromagnetic interference of booster components with the stored beam.
- **And the disadvantage of:**
- Producing variable heat loads in the storage ring and on the optical components of the experimental set ups which affect the stability of the stored beam and the properties and lifetime of the optical components.
- Reducing the averaged photon flux.

Topping-up

A decorative graphic at the top of the slide consists of two rows of circles. The first row has two circles: the left one is solid light blue and contains the text 'Topping-up', and the right one is a white circle with a light blue outline. The second row has three circles: the first and third are solid light blue, and the middle one is a white circle with a light blue outline.

- The topping up mode of injection where one keeps the stored current close to its maximum value with frequent short injections is very attractive when the lifetime T_0 is rather short (a few hours). It avoids the above mentioned disadvantages but:
 - The experiments have to cope with a non smooth decay function of the stored current,
 - The injector has to run throughout the time the storage ring is operated. This results in higher operation costs,
 - The detectors on the experiments must be gated in order to prevent taking data during injection,
 - Topping up is now used at many Synchrotron Radiation sources.

Extraction



- Extraction is the mechanism used to remove beam from an accelerator. Different techniques are used to eject beam from circular machines:
 - Fast one-turn extraction is used in the transfer of beam from one circular machine to another.
 - Experimental facilities generally require slow-extracted beam, with a smooth and uniform spill.
- As for injection, extraction is generally performed in the horizontal plane.

Fast extraction



- The first stage of fast extraction consists in creating an **orbit bump** to slowly bring the beam as close as possible to the first extraction septum.
- Then a **fast kicker** magnet is powered such that the beam is deflected into the extraction channel where it receives sufficient angular deflection to leave the machine. If particles arrive at the kicker while it is ramping, they will be killed onto the septum blade. As a consequence, the rise time of the kicker must be as short as possible.
- The duration and switch-on/switch-off times of the kicker pulse depend on the mode of extraction. Typical values of rise and fall times are 40 to 50 ns.

Fast extraction



- For one-turn extraction, the rise time must be short compared to the revolution period of the ring (then only a small fraction of the particles are lost), the pulse duration is the revolution period and the switch-off time is arbitrary.
- For bunch-by-bunch extraction, the rise time and the fall time must be shorter than the time interval between two successive circulating bunches, and the pulse duration is the bunch repetition period (or less).

Fast extraction

- As for the fast injection, the kicker must deflect the beam by

$$\theta_k = \frac{x_s}{\sin \mu_x \sqrt{\beta_x^k \beta_x^s}}$$

- β_x^k, β_x^s : beta functions at the kicker and septum
- μ_x : betatron phase advance from the kicker to septum
- x_s : required displacement at the septum entry.
- The initial orbit bump is used to reduce the value for x_s .
- Extraction efficiency as good as **100%** can be achieved.

Fast extraction

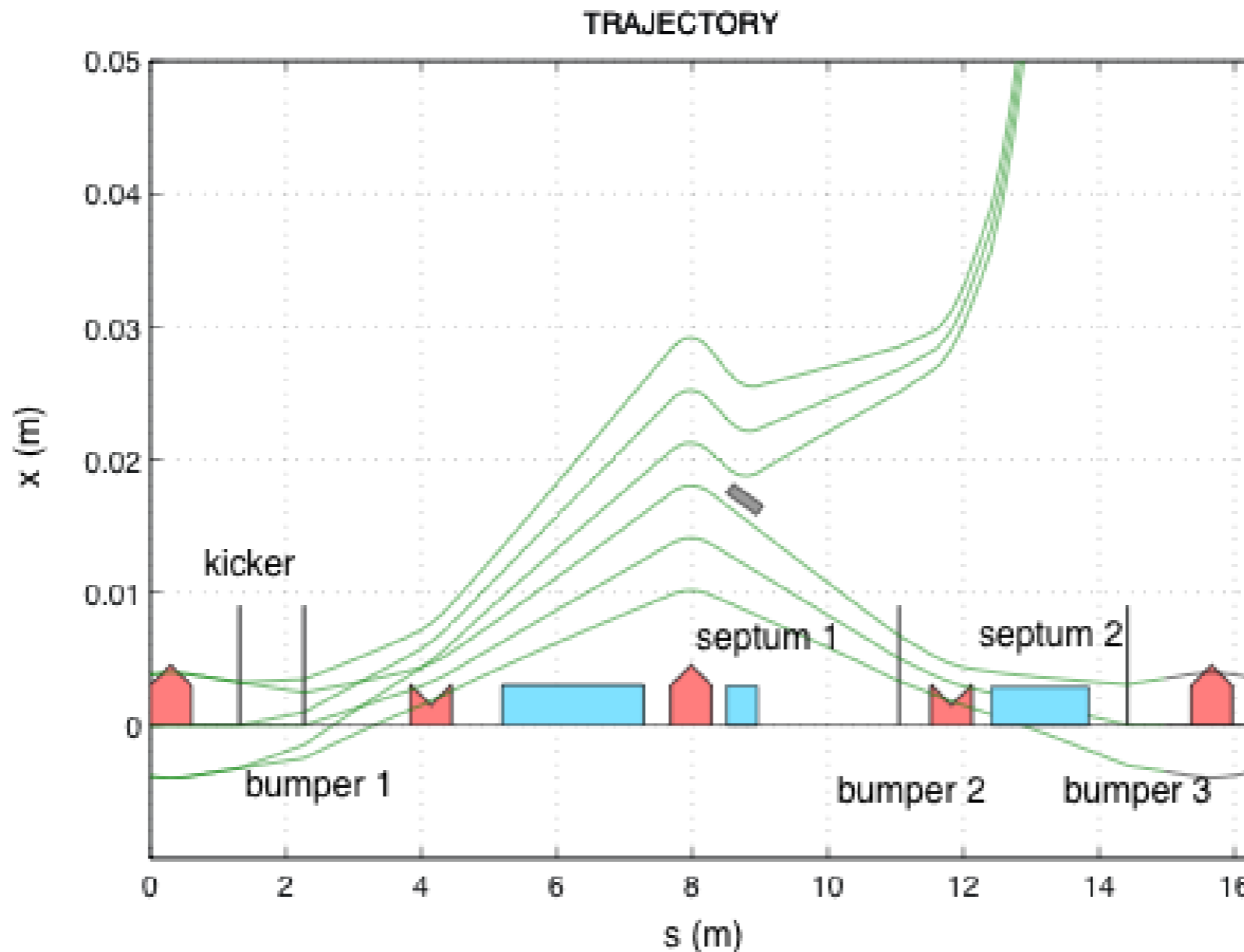

Schematic view of extraction region (ESRF Booster), with three slow bumpers B1, B2, B3, 2 extraction septum magnets Se_1 and Se_2 and one fast kicker magnet Ke .

Resonant extraction



- Slow extraction can be achieved by **controlled excitation of a non-linear betatron resonance** of the ring, often a third-integer resonance.
- The efficiency of slow extraction depends on the thickness of the first ejection septum as compared with the growth of the resonant betatron amplitudes in the final few turns before extraction.

Resonant extraction: principle

- The trajectory of a particle which has a horizontal tune $Q_x = p/3$ is closed over 3 turns. Such a motion can be described by 3 fixed points P , P' and P'' in the normalised phase space diagram: after 3 turns the particle is back to the same angle and position.
- In the presence of a sextupolar perturbation, the particle will get an angular kick proportional to the square of its amplitude, but will still describe a close trajectory between the 3 fixed points P , P' and P'' .
- A particle which has a horizontal tune $Q_x = p/3 + \varepsilon$ (ε small) describes triangular trajectories in the normalised phase space diagram.
- The stable area is defined by three separatrices. The particles which start to move inside this triangle are stable and describe closed trajectories. The particles which are outside this triangle are unstable and describe open trajectories with a diverging motion to the outside.

Resonant extraction

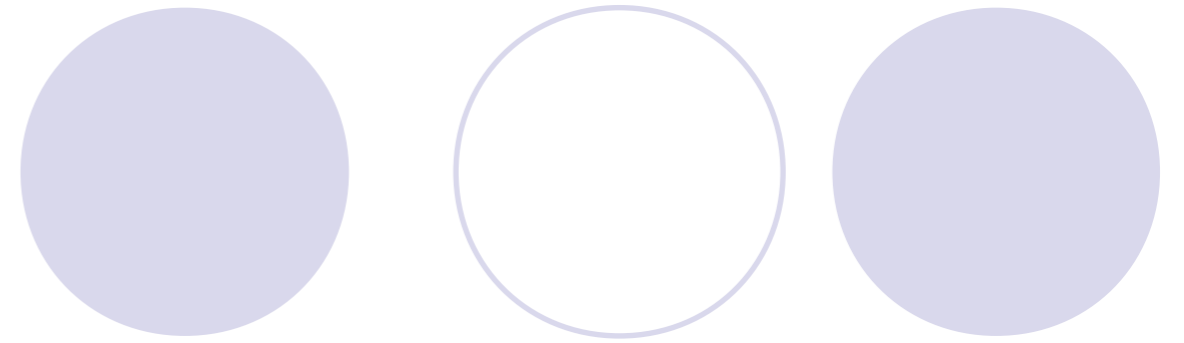

P, P', P'' : fixed points ($v_x = 1/3$)

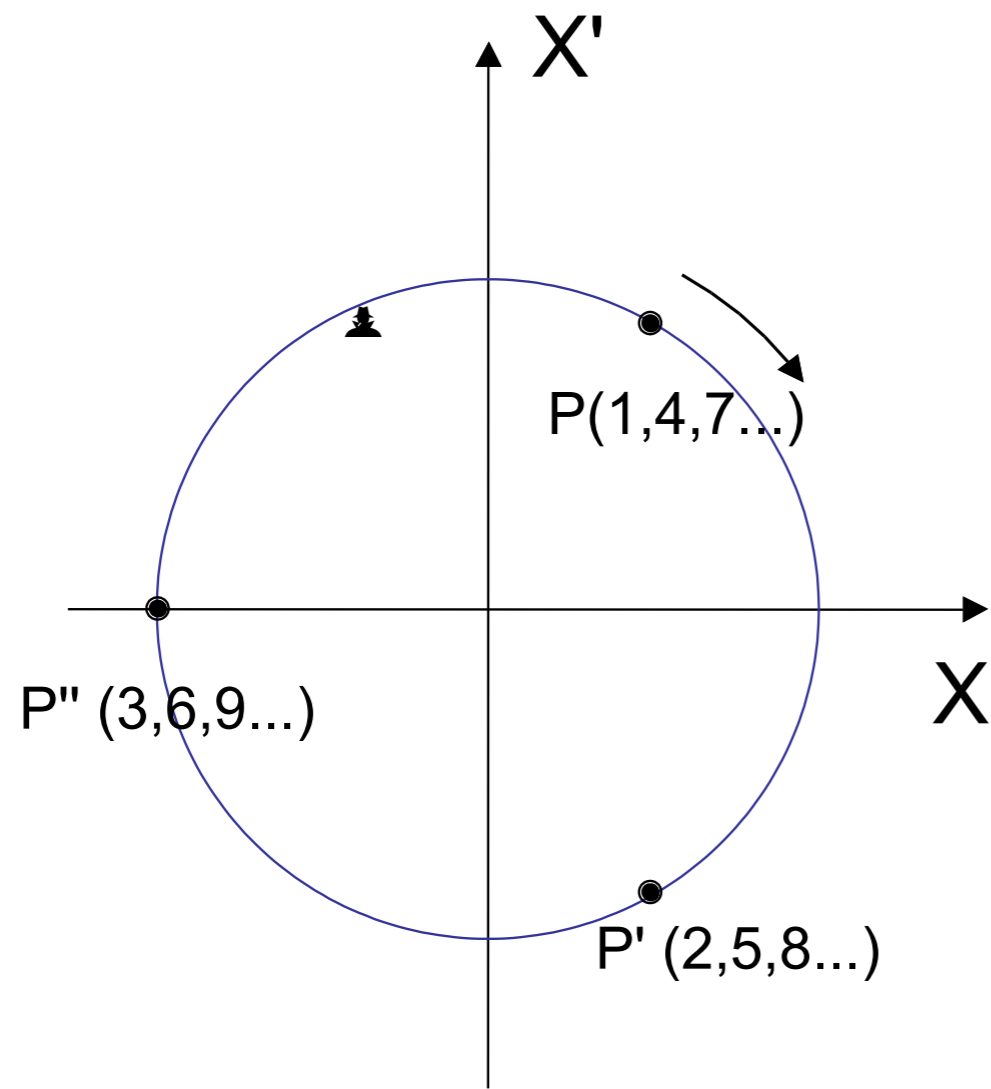

Without sextupoles

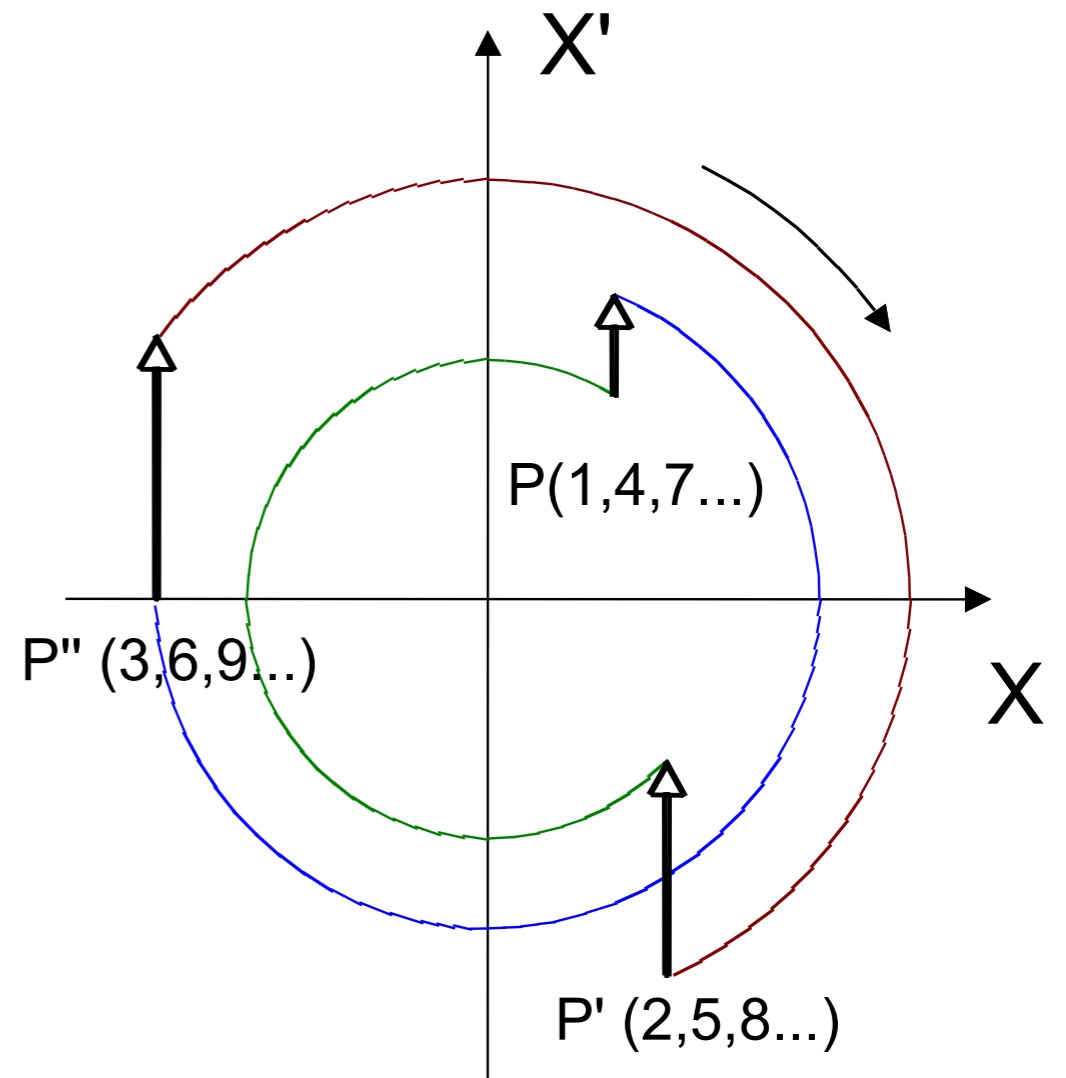

With sextupoles

Resonant extraction

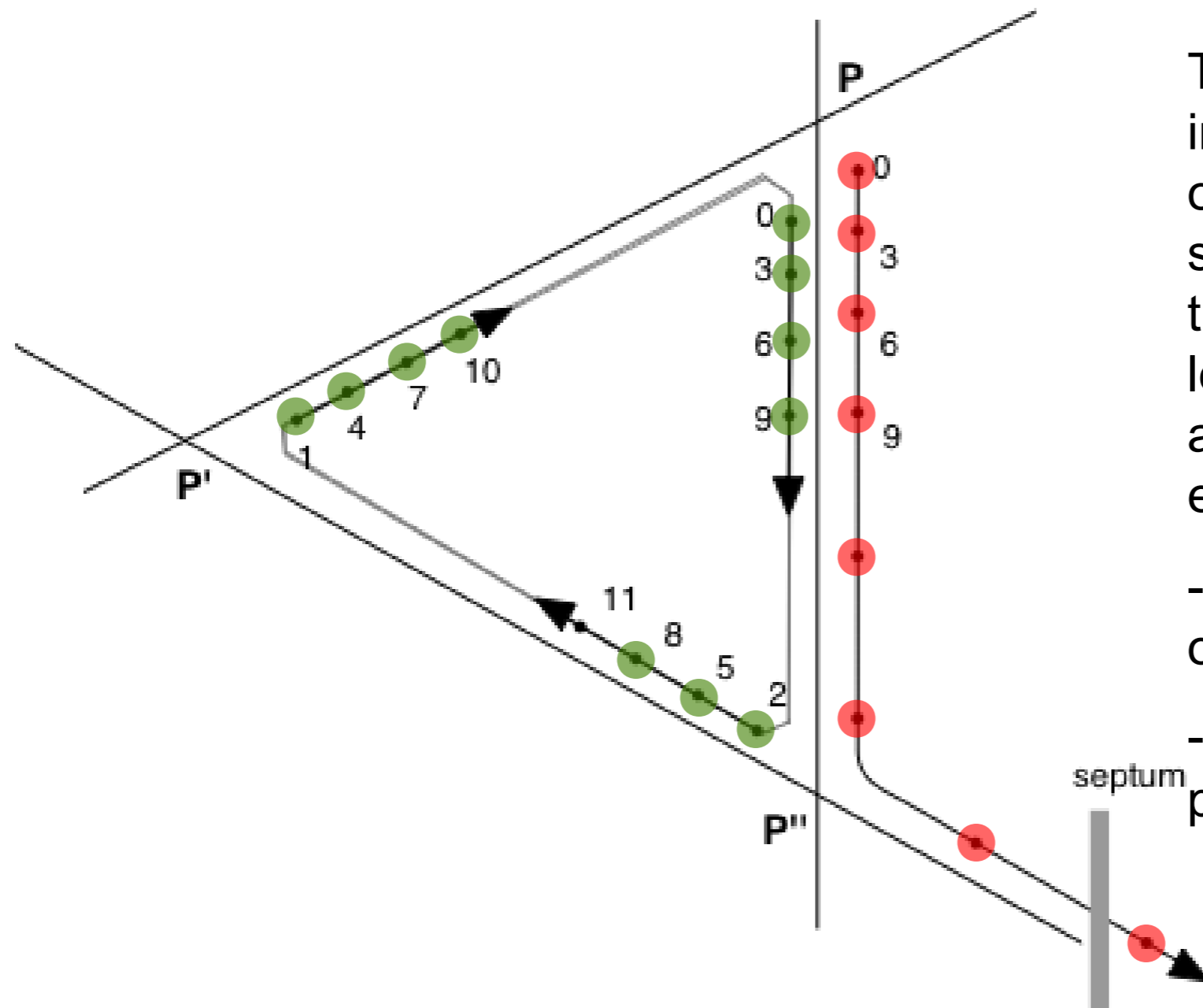

The resonant extraction consists in shrinking progressively the area of the triangle defined by the separatrix so that the motion of the particles becomes unstable, leading to a larger and larger amplitude of oscillation. The extraction speed is tuned using:

- Sextupoles to control the shape of the separatrix.
- Quadrupoles to control the proximity with the $1/3$ resonance.

Resonant extraction



- Particles are brought closer to the resonance by varying their tune with:
 - A fast quadrupole
 - A finite chromaticity and RF settings.
- At the location of the extraction septum, within the last three turns the betatron amplitude of the particle must have grown enough to jump from one side of the septum to the other. This requires a very thin septum blade (electrostatic septum).
- This growth in amplitude of a particle depends on its momentum, its initial amplitude and the proximity of its tune to the resonant tune value (ϵ).
- The dispersion in angle and position of the extracted beam is difficult to control.



Magnetic elements

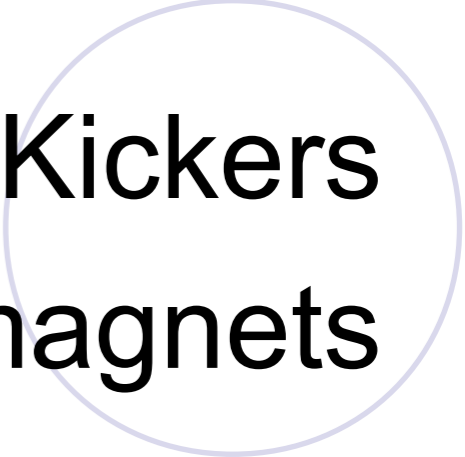
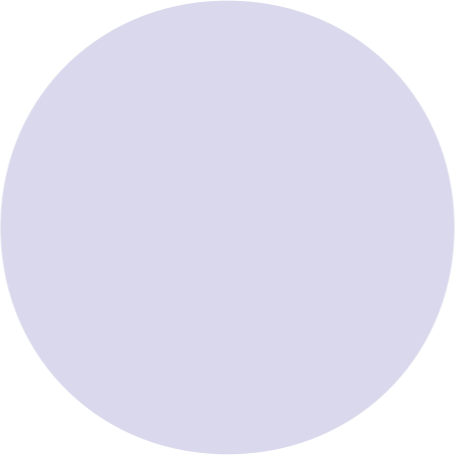
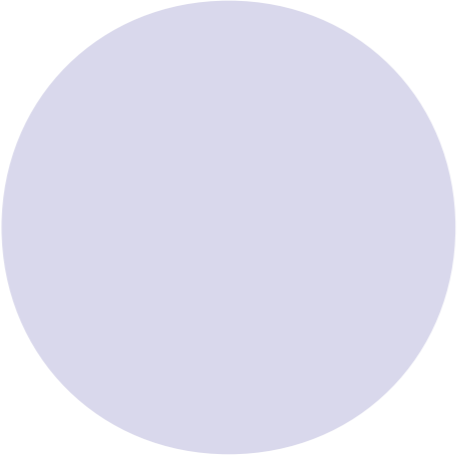

Kickers

Septum magnets

Kicker magnets



- Fast kicker magnets need to be switched on/off in times typically of 50 to 150 ns. This is only possible with magnets with extremely small inductance. Small inductance magnets are usually “air coil magnets”, which cannot produce a high magnetic field without going to impracticable currents.
- The kickers are powered by pulse-forming networks (PFN) which are charged some time prior to the injection and rapidly discharged via fast switches (thyratrons).
- Ferrites are frequently used to contain the field, usually they cannot be tolerated inside the vacuum of the ring, and must be installed around a ceramic vessel. Such ceramic vessels have to be coated with a thin conducting layer deposited on the inner wall of the ceramic, in order to ensure the circulation of the beam image current.

Kicker magnets

- Typical layout of a kicker power supply:

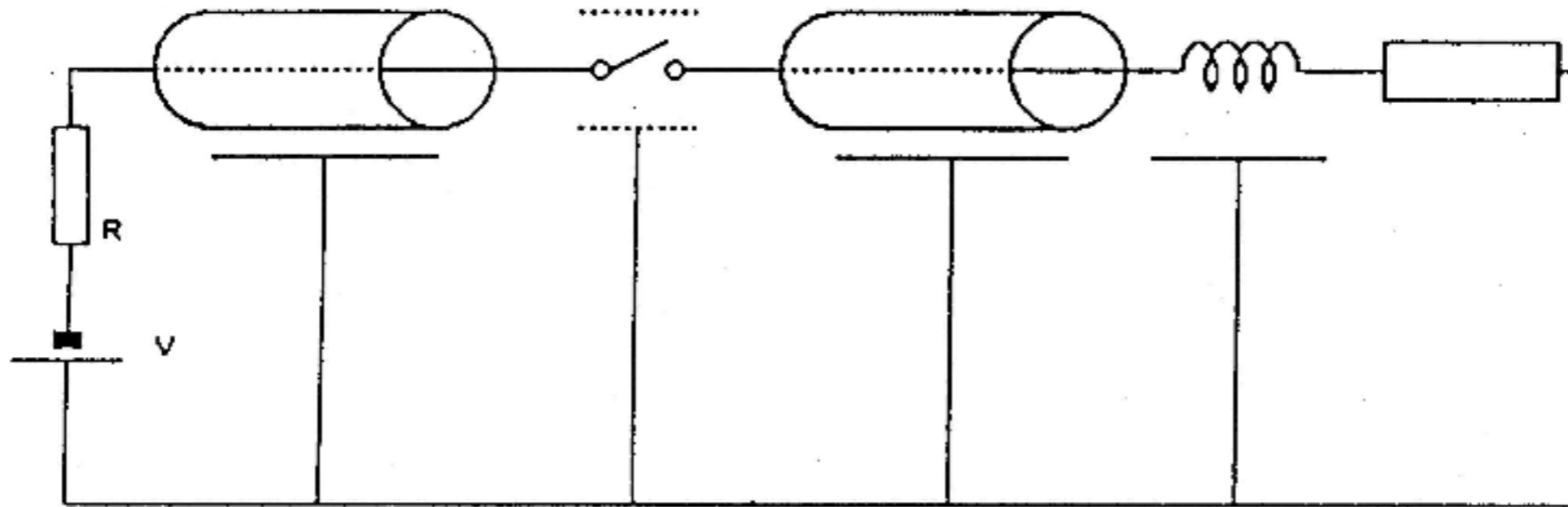

DC-HV
Power
supply

HV-Coax
cable acting
as PFN

Thyatron
switch with
coaxial
mounting

Coax cable
to kicker
magnet

Kicker
magnet
constructed
as delay line

Z termination

Kicker magnets

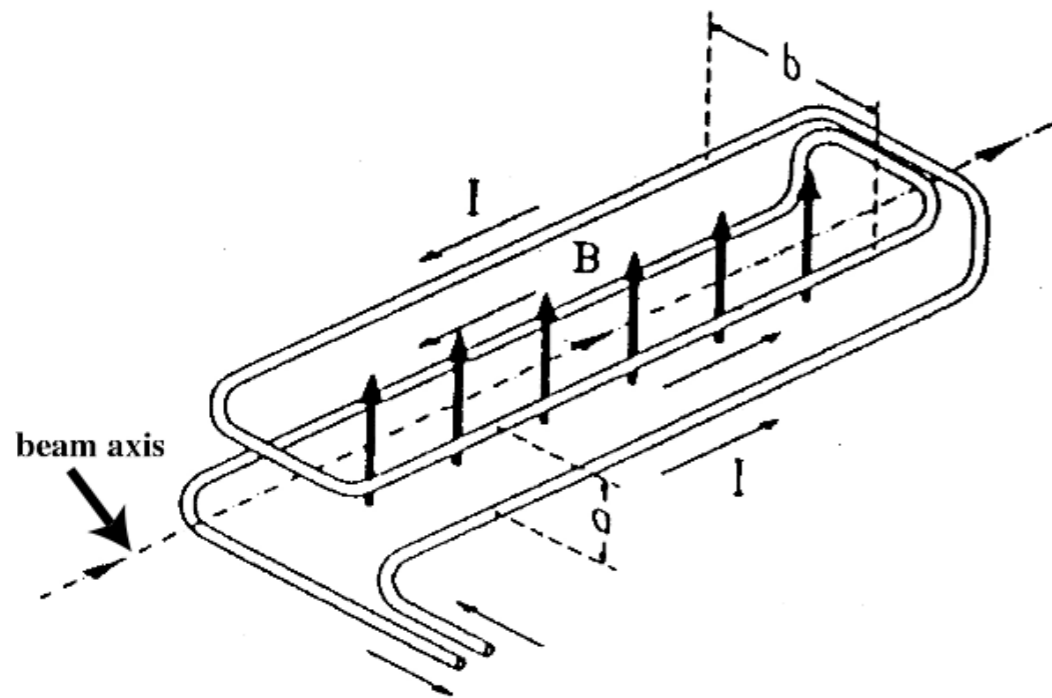

Example of a kicker magnet coil

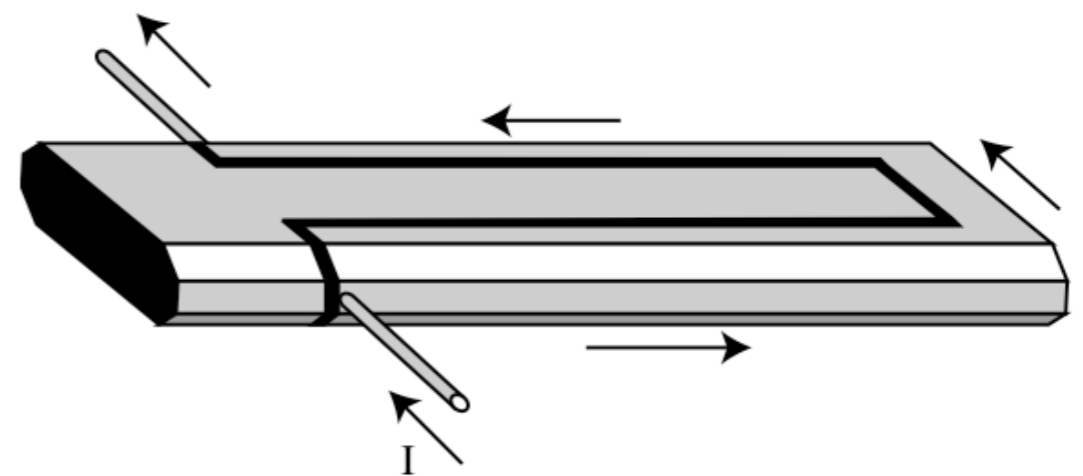
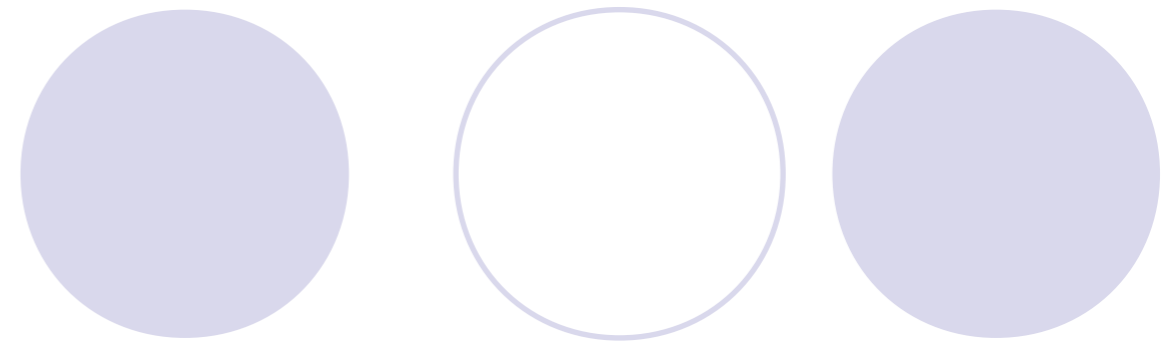

Design of a Kicker magnet for DELTA (Dortmund) The shape of the beam vessel continues to the vacuum chamber cross section, leading to an **extremely low coupling impedance** to the beam (i.e. low loss factor).

Kicker magnets

Parameter	Typical Value
Length	0.45 - 2 m
Field	20 - 60 mT
Impedance	2 - 30 Ω
Peak current	1 - 5 kA
Peak voltage	20 - 80 kV
Rise time	25 - 1000 ns

Injection/Extraction

Septum magnets

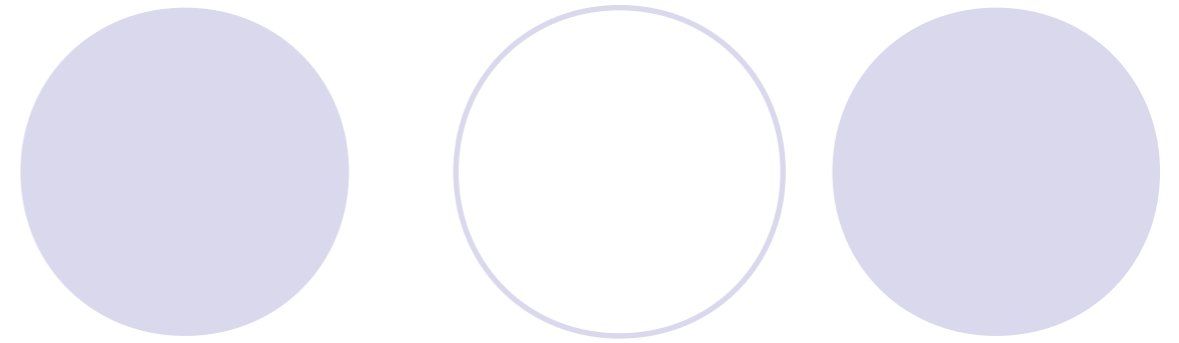

- Given the very small bending angle of typical kicker magnets, it would be nearly impossible to bring the delivered beam sufficiently close to the aperture of the accelerator without interfering with the magnet structure of the accelerator. One therefore uses a second bending magnet, which allows to bring the beam with a large bending angle very close to the closed orbit without affecting particles travelling on the closed orbit: a septum magnet.
- A septum has a blade that separates beams and provides different deflecting fields on either side of the boundary.
- Septum magnets have the characteristic of providing a high magnetic field for the delivered beam very close to the aperture of the accelerator without creating any perturbing magnetic field on the axis of the accelerator. Schematics of such septum magnets are shown below: The separation between the high field in the injection channel from the zero magnetic field of the accelerator axis is provided by a septum blade acting as part of the magnet coil or by an eddy current shield.

Septum magnets

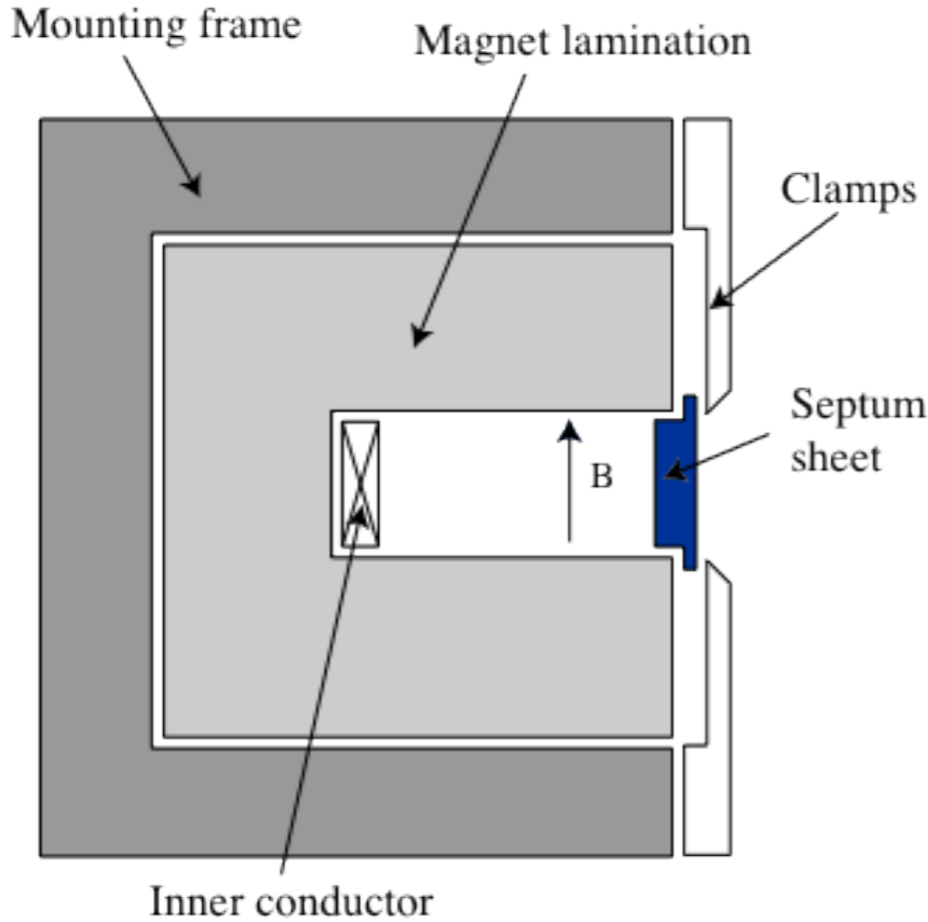

Active septum
DC or pulsed magnet

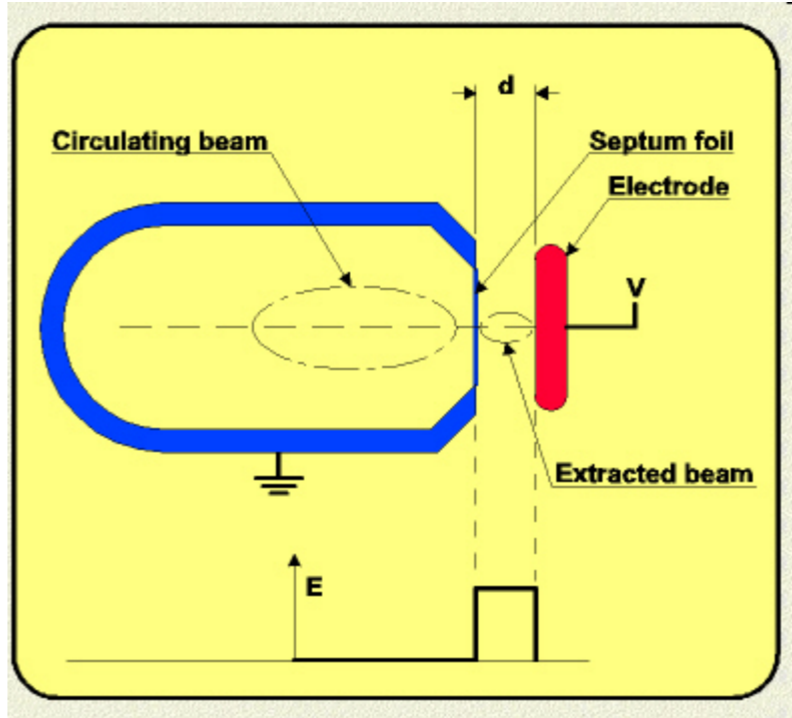
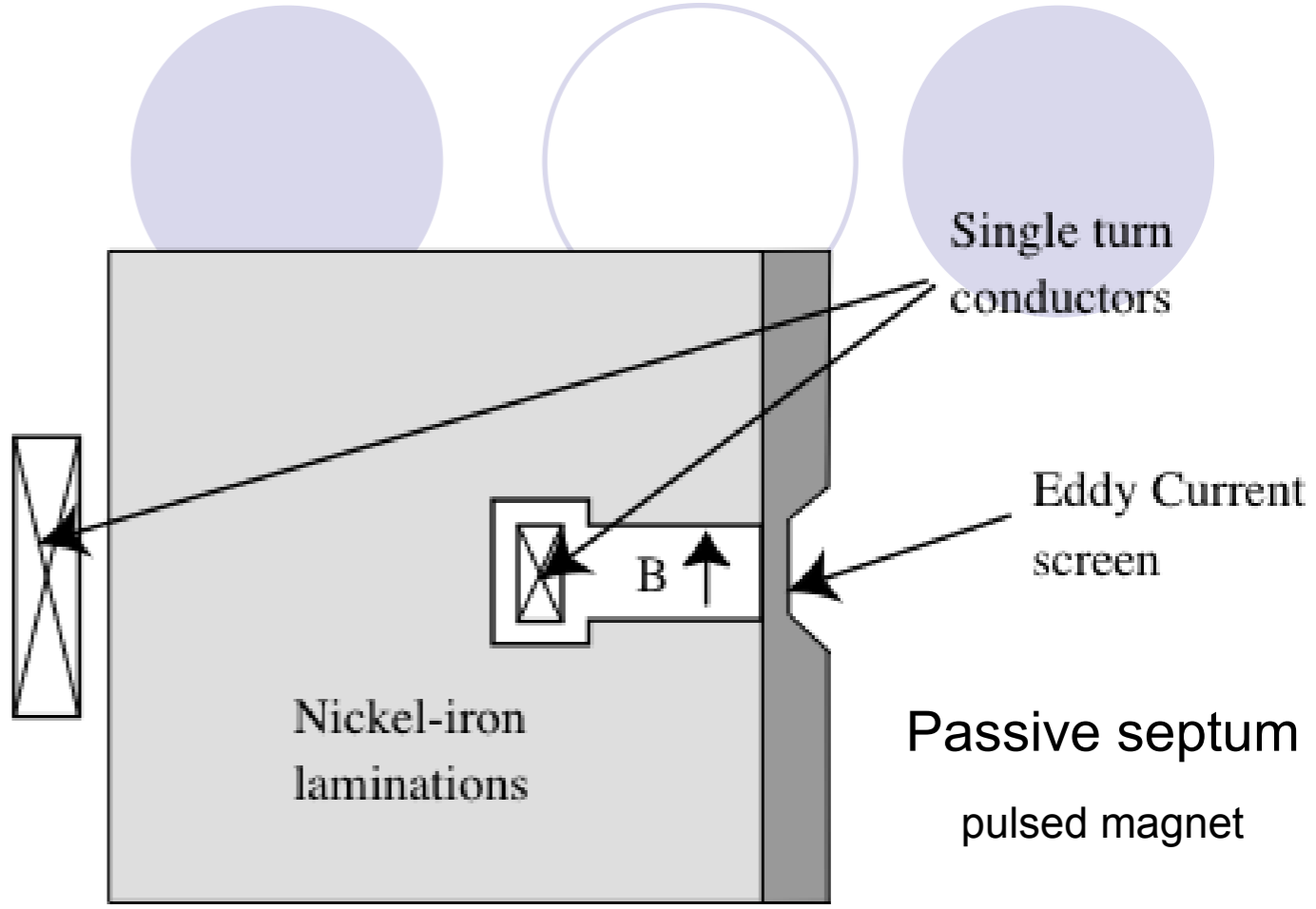

Electrostatic septum
DC

Injection/Extraction

Example: LHC injection chain

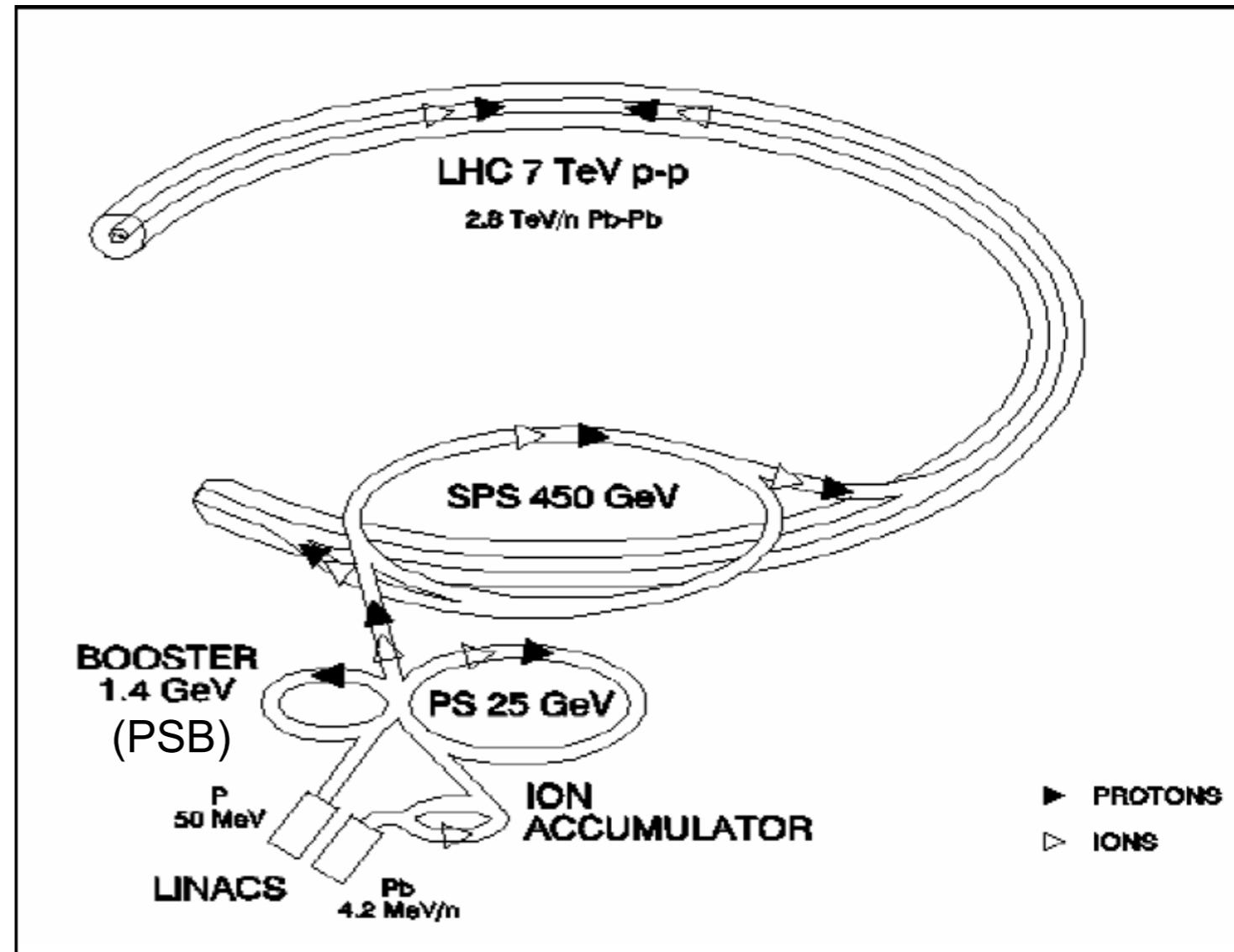
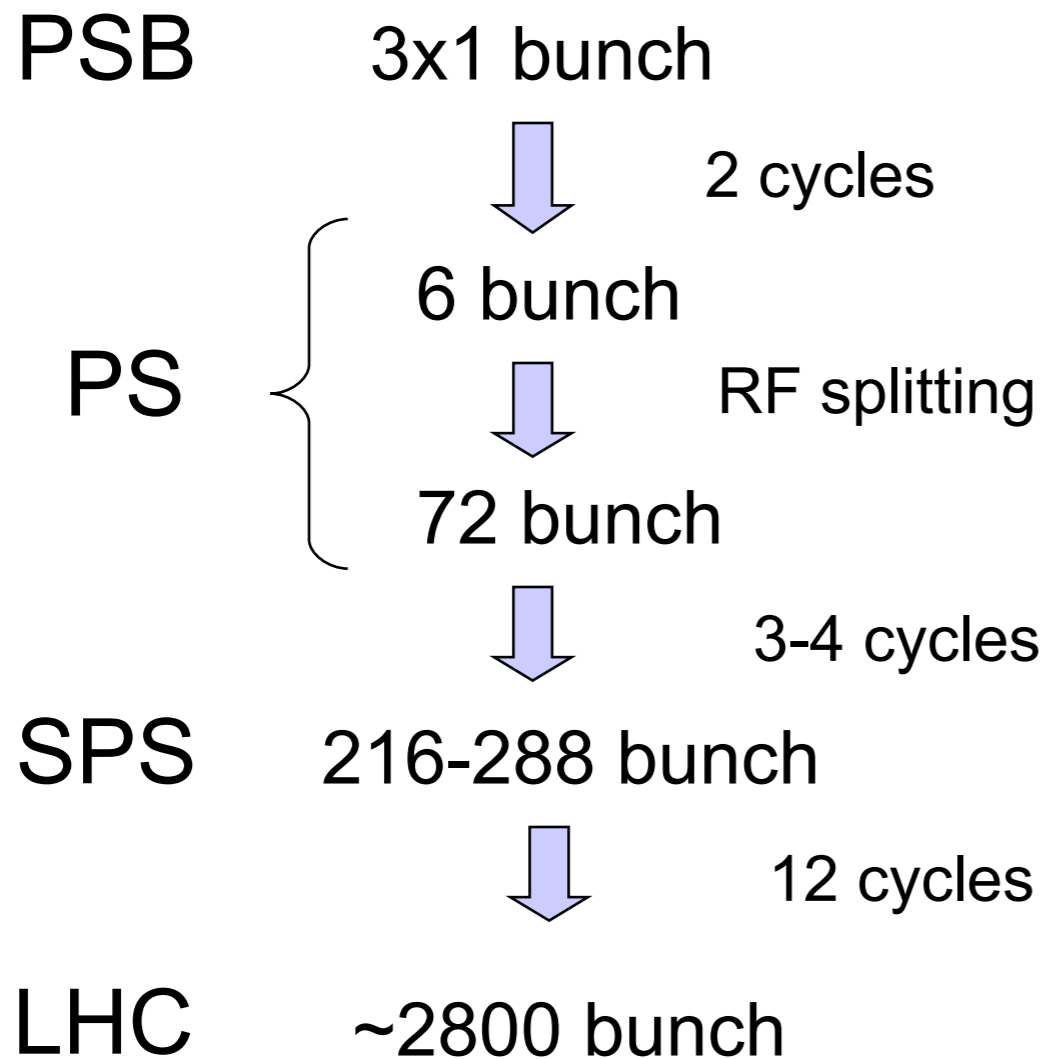

~85% injection efficiency

Example: LHC injection chain

PSB has four accelerators on top of each others which can be synchronised to send puls train in a single transfer line.

The second scheme presented is actually used as space charge forces in the PSB where to strong for 2 LHC bunches in 1 PSB ring

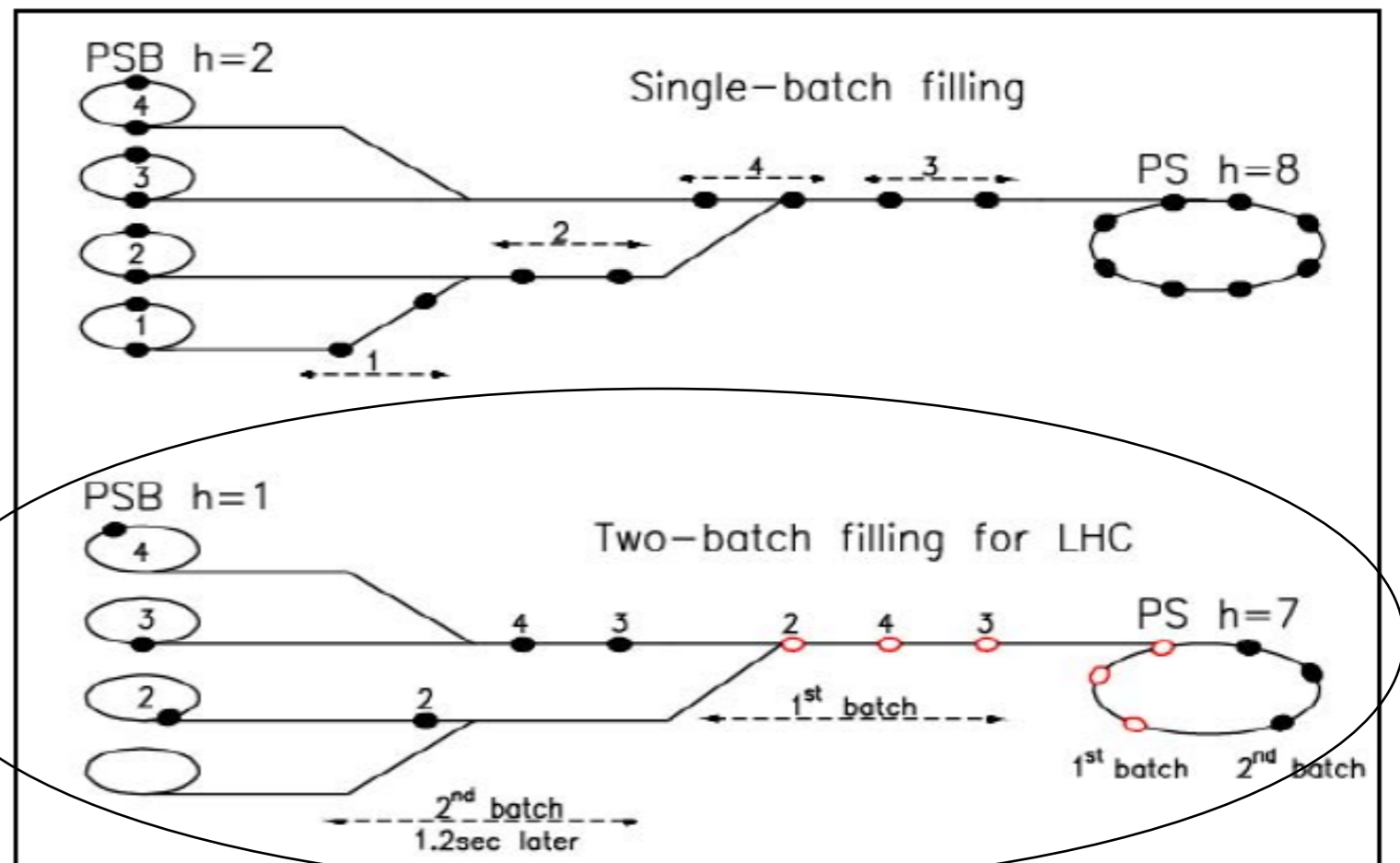

Complex RF manipulation called beam splitting is then dividing the 6 bunches injected in the SPS into 72 bunches.

Example: LHC injection chain

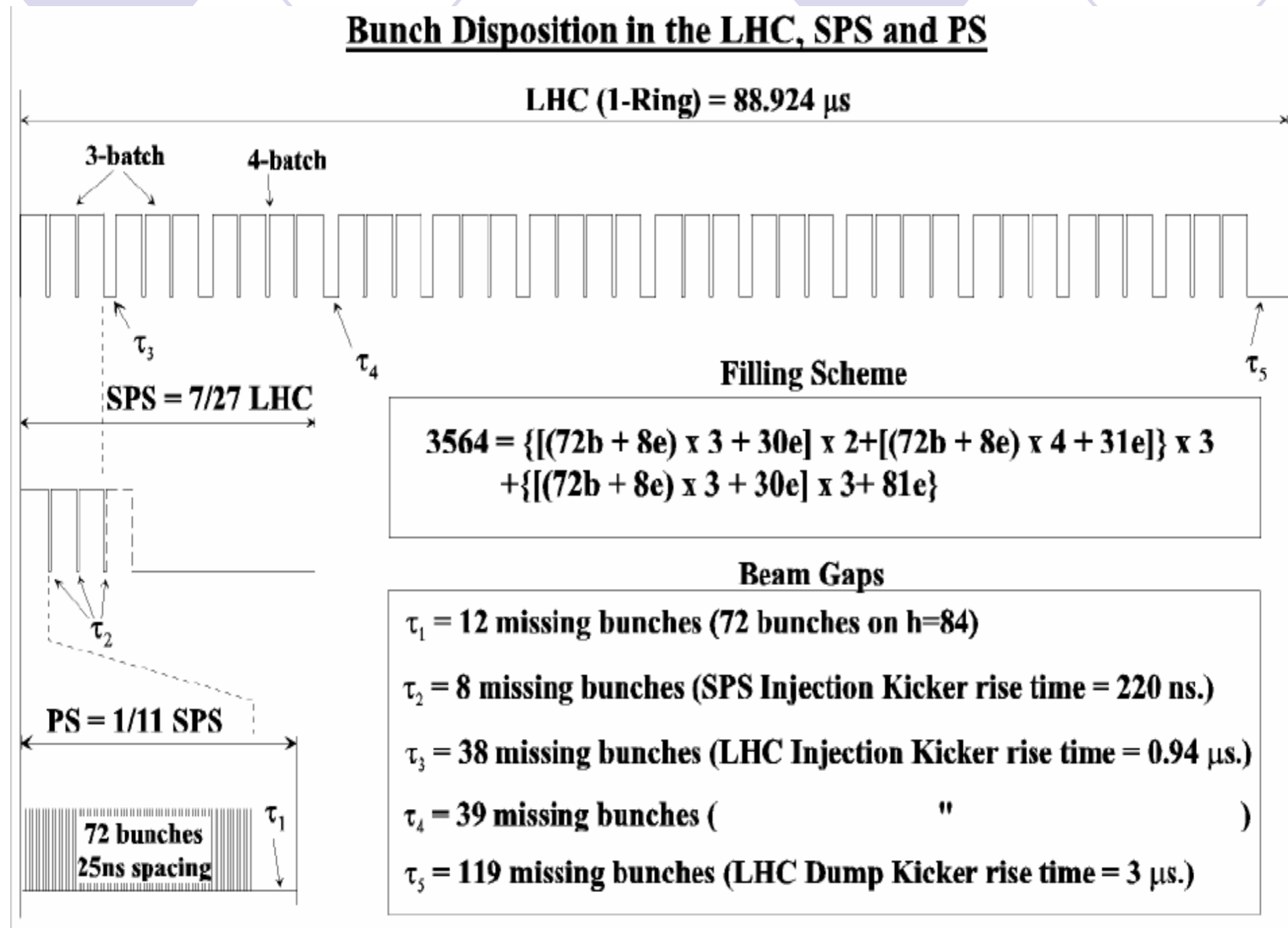

[ref]: LHC design report

Example: PS extraction for FT

Extraction over 5 turns:

$Q_h = 0.25$

Closed bump on:
Part of the beam is sent in the extraction channel
Part of the beam is lost on the septum blade

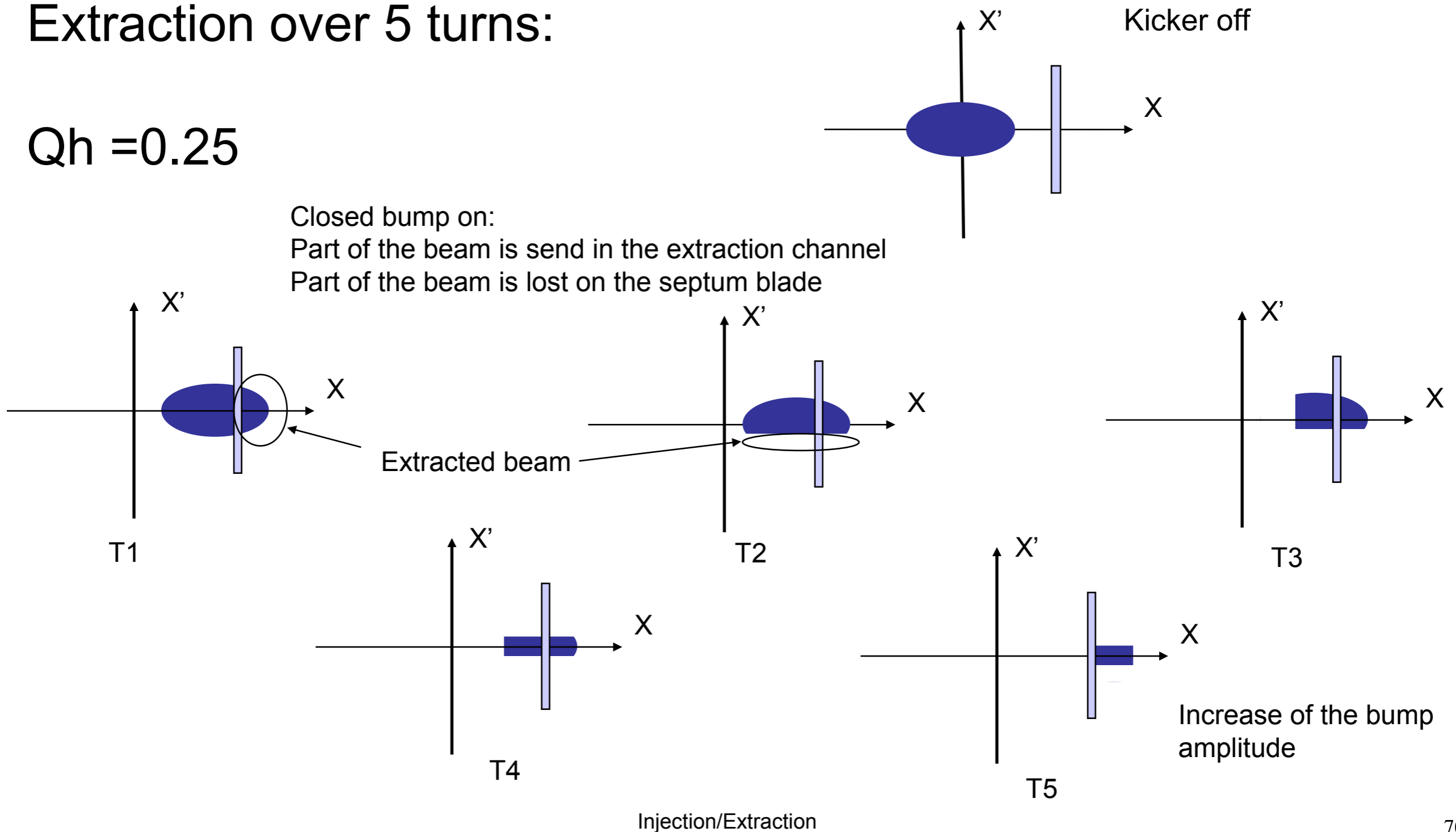

Injection/Extraction

Example: ESRF injection chain

Synchrotron light source, 6Gev electrons

200 Mev linac

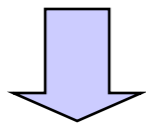

Single turn injection

6Gev Booster synchrotron 300m
~335 bunches

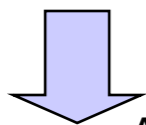

Single turn extraction
+
Accumulation in the storage ring

6Gev storage ring 844m
992 bunches

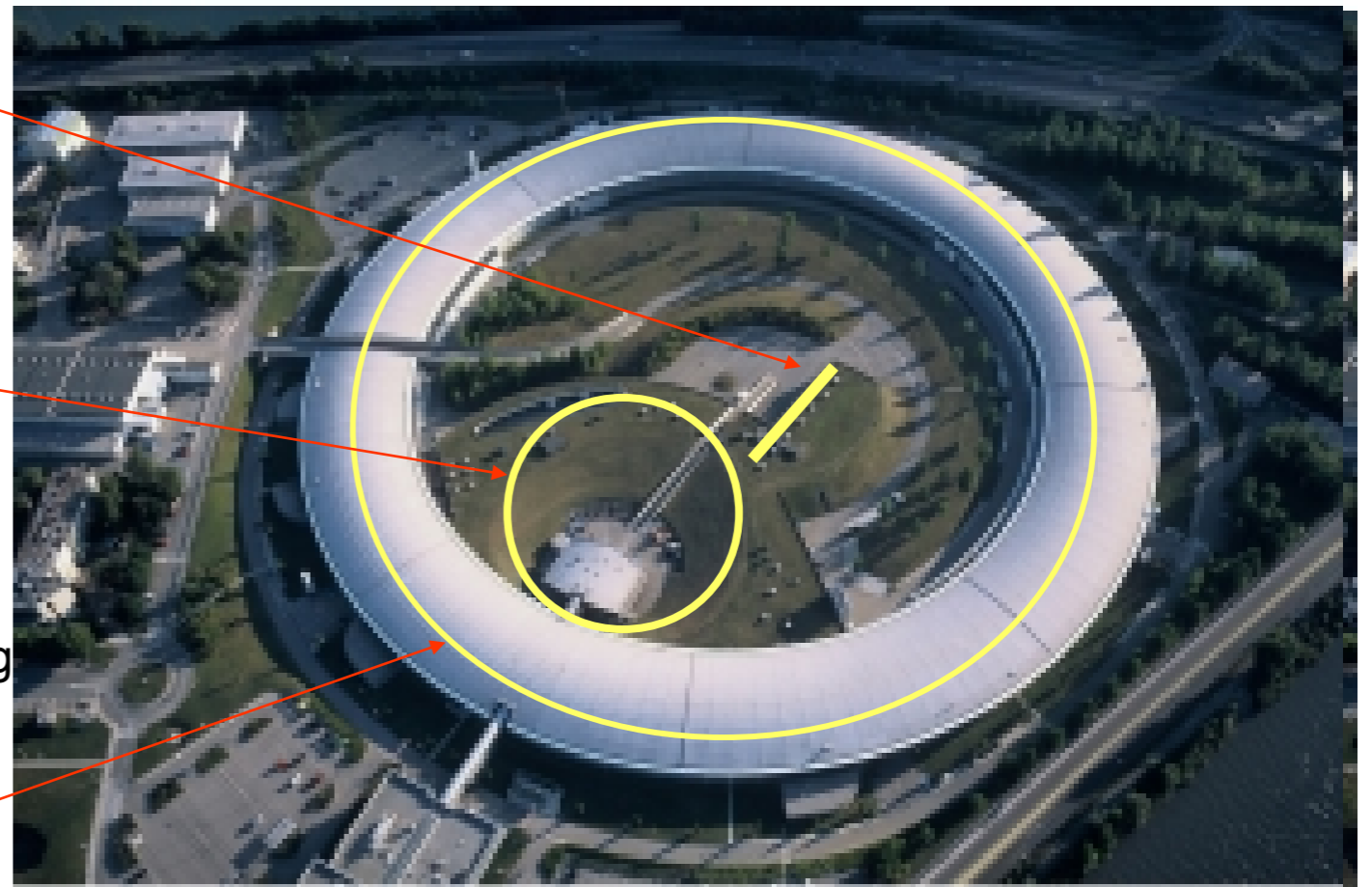

©ESRF - Denis Marel

Example: ESRF injection chain

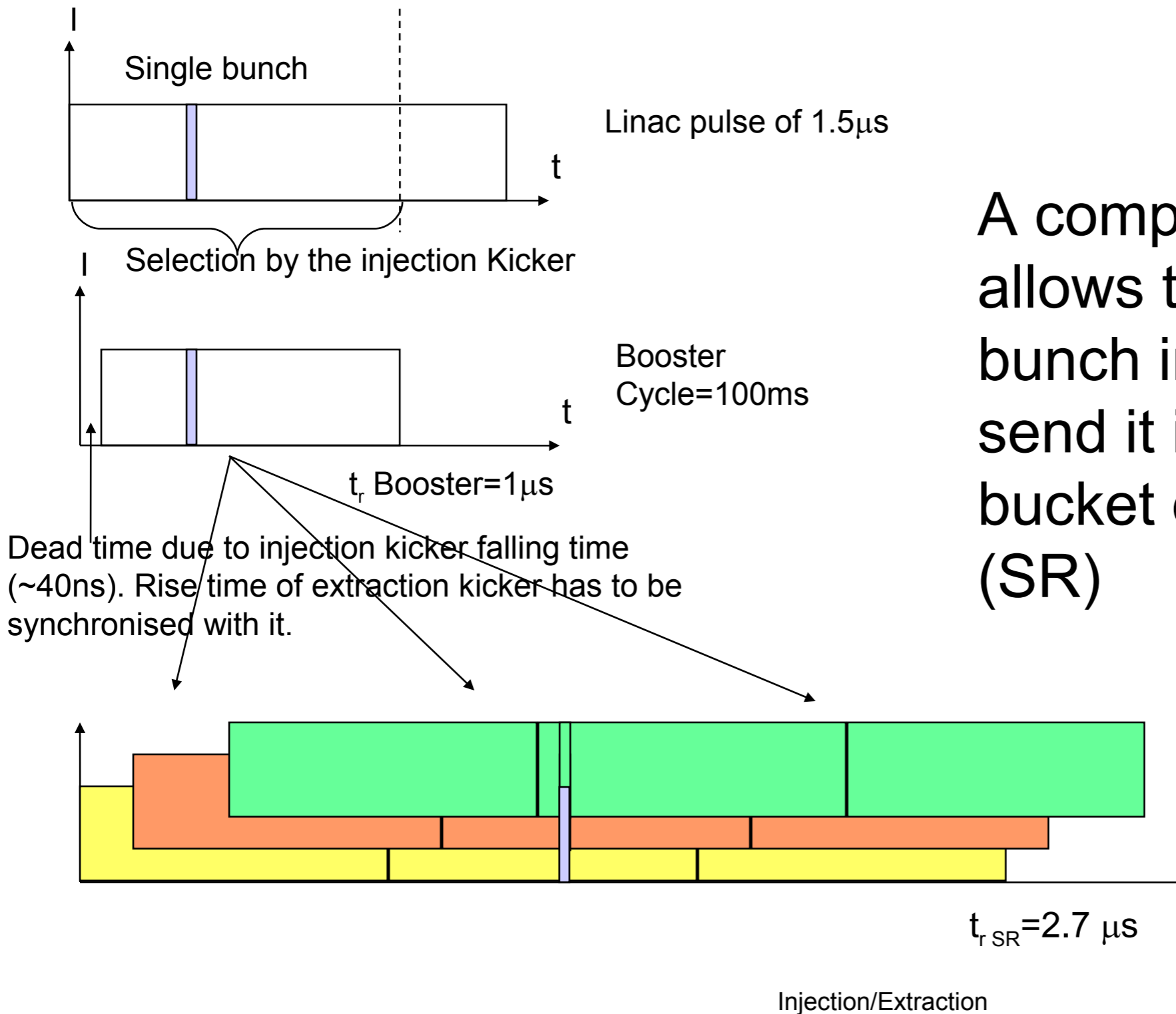

A complex timing system allows to create a single bunch in the booster and to send it in a specific RF bucket of the Storage Ring (SR)

Storage Ring accumulation. About 100 pulses are needed to reach 200mA stored current.

Example: ESRF injection chain

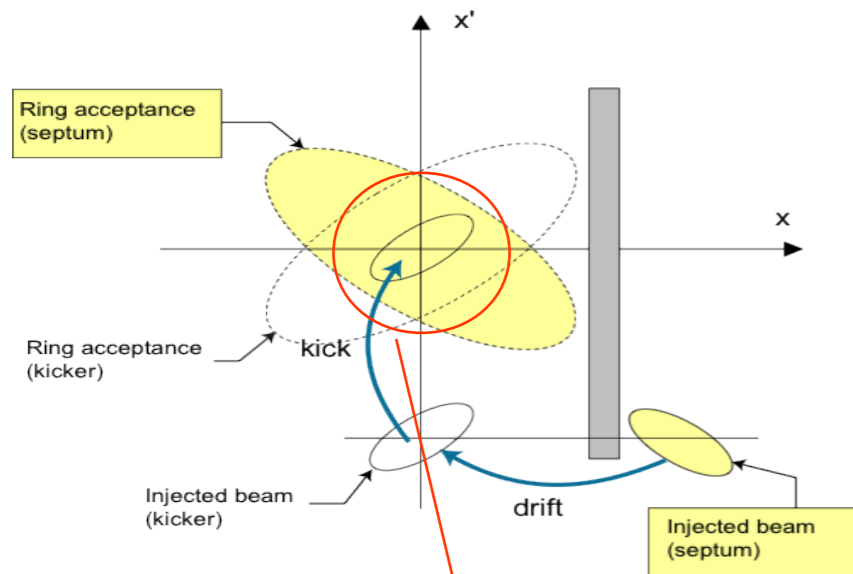

Linac to Booster injection

After acceleration and damping in the booster, the beam has a horizontal emittance of $\epsilon_h = 100\text{nm}$

Injection into SR

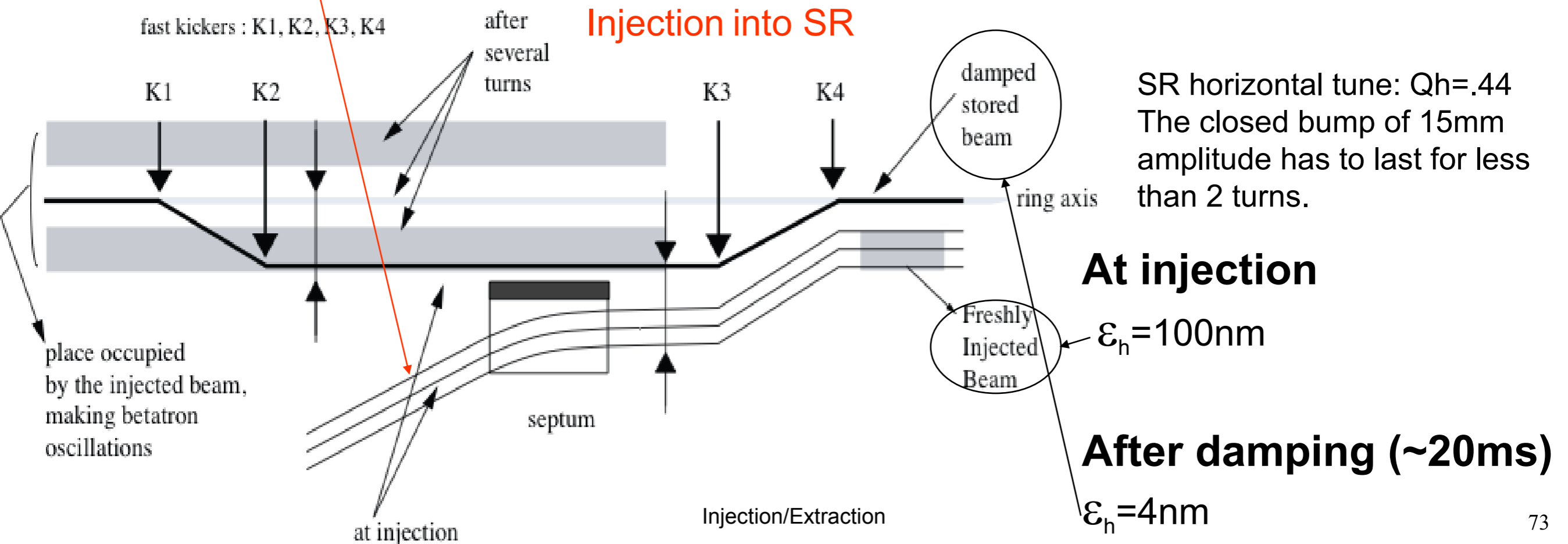

Application

In an electron machine, using a four kicker bump injection scheme for accumulation, there is a fire in the power cabinet of the kickers power supplies and they all melt.

You only have one spare and you get a direct call from the director telling you his son is coming tomorrow to make an experiment that will of course win the Nobel price, so you'd better find quickly a solution.

Do you have a chance to keep your job by finding a solution to accumulate only with one kicker?

Do you have a chance of getting a 100% injection efficiency (and get promoted)?

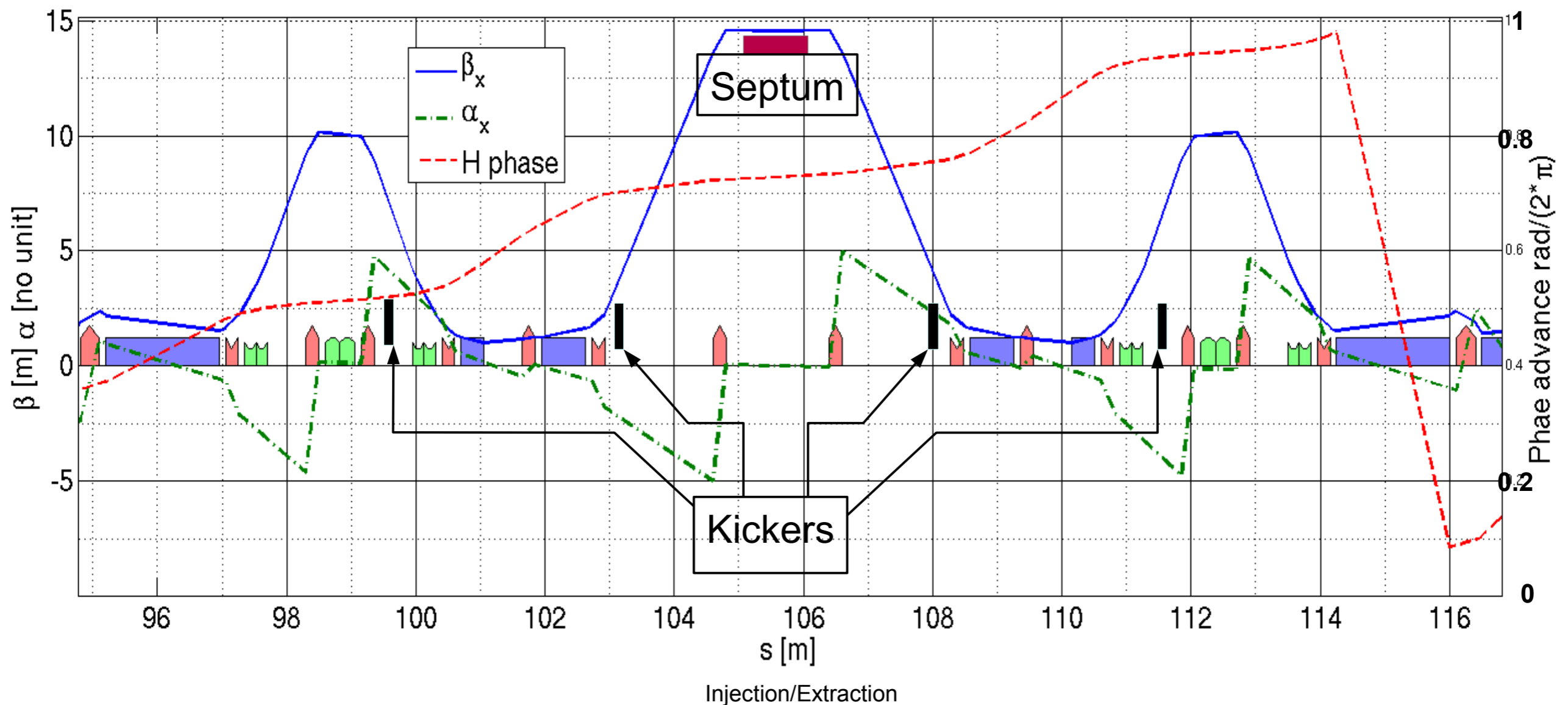

Normalised phase space at septum location

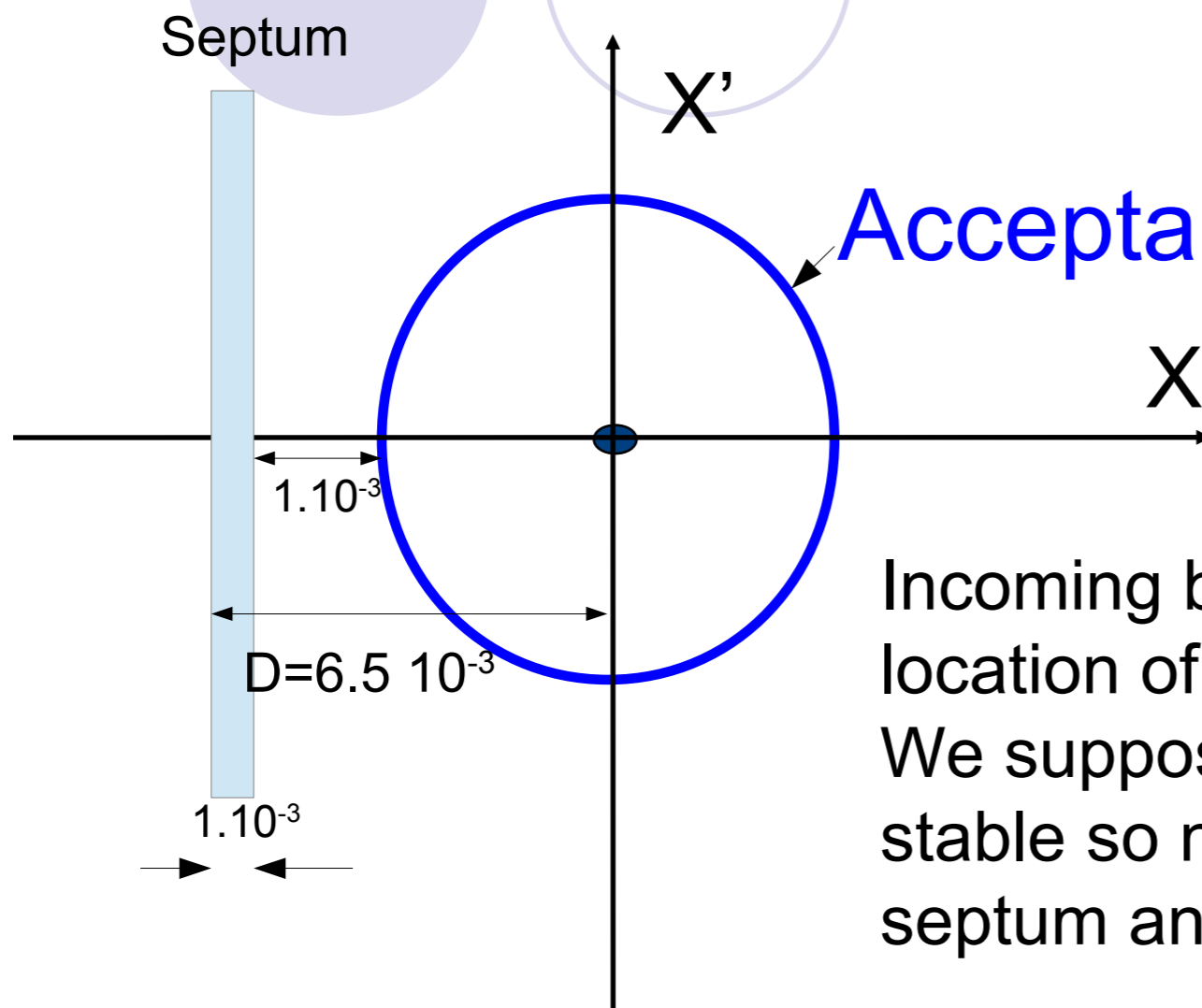

Acceptance: $\sqrt{(X^2 + X'^2)} < 4.5 \cdot 10^{-3}$

Incoming beam has a half width at septum location of $1 \text{ mm}^{1/2}$ in normalised phase space. We suppose the orbit of the incoming beam is stable so no clearance is needed between the septum and the injected beam.

Acceptance in this case is defined by a limiting aperture somewhere around the ring but not by the septum blade.

The equilibrium emittance after damping is considered infinitely small compared to the acceptance, so the circulating beam can be considered as a point like beam (width=0).

Correction

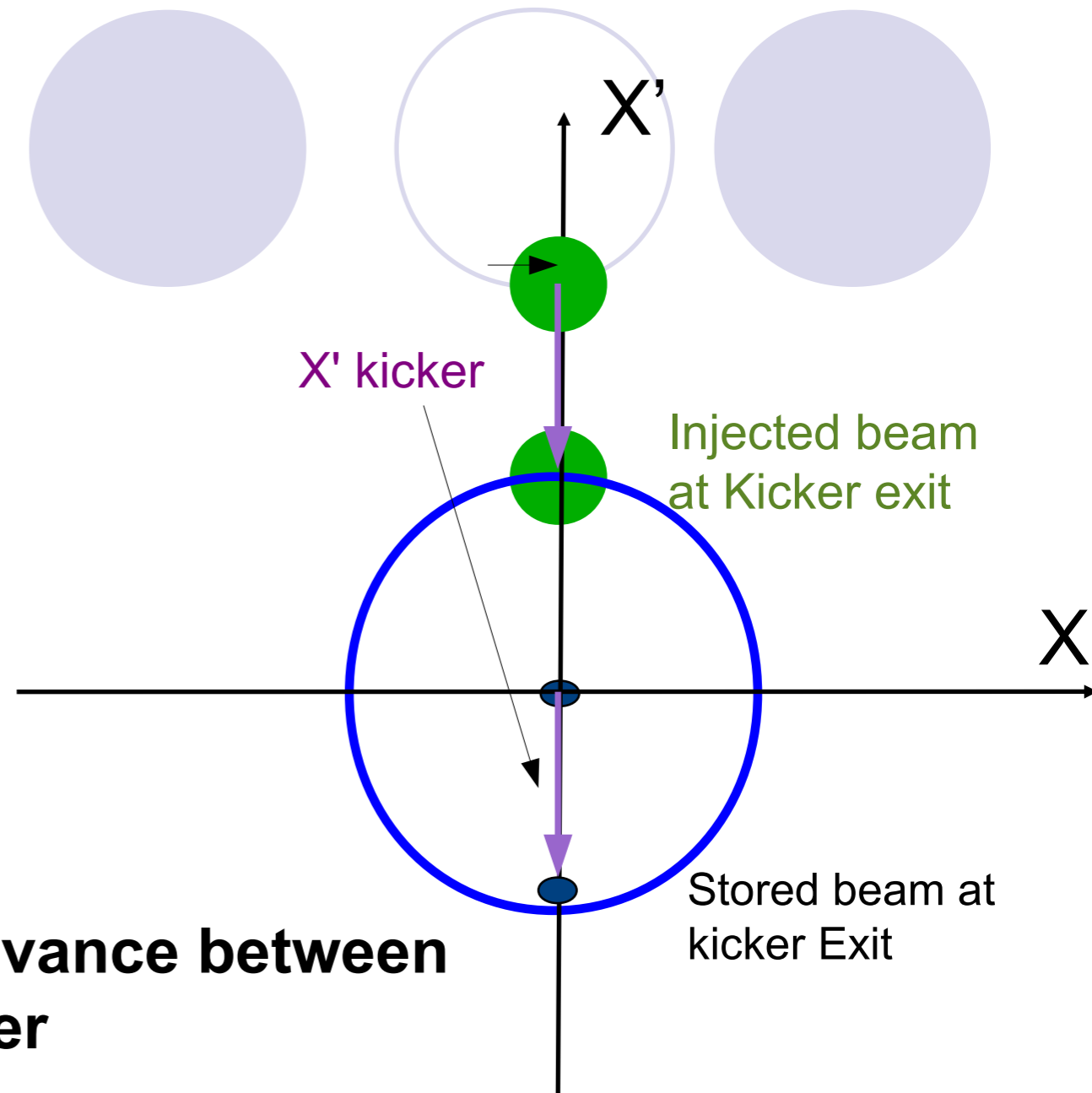
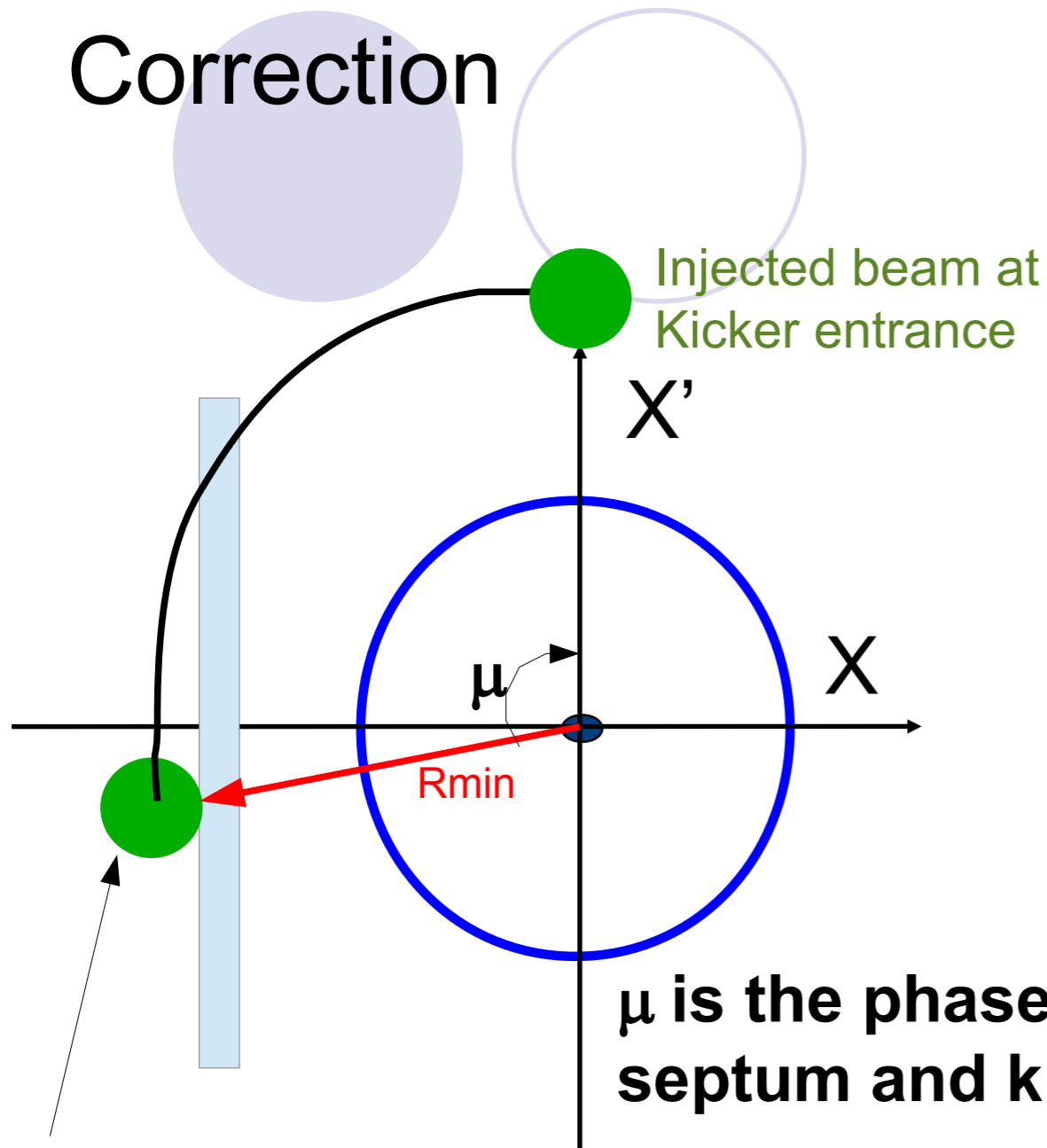

Injected beam at septum

Condition for injection efficiency > 0 : $R_{min} < 2 \times R_{acc}$ (for a point like stored beam)

Condition for injection efficiency = 100% : $R_{min} + 2 \times \sigma_{inj} < 2 \times R_{acc}$

Optimum condition:
 $X_{inj} = 0$ at kicker location



X' at septum location is given by this Condition and the phase advance μ

Injection/Extraction



Again the optimised phase advance μ to minimise R_{min} would be $\pi/2$.
 Also the kicker has to be after the septum.



The fourth kicker is the most relevant, it has a μ equal to $\sim 0.2 \cdot 2\pi$

$$X'_s \approx R_{min} \times \sin(\mu - \pi/2)$$

$$R_{min}^2 = D^2 + X_s'^2$$



$$R_{min} = \sqrt{\left(D^2 / \left(1 - \left| \sin(\mu - \pi/2) \right| \right) \right)}$$

In our case: $\mu = 0.2 \cdot 2\pi$
 $D = 6.5 \cdot 10^{-3}$



$R_{min} = 7.82 \cdot 10^{-3}$ (while $2 \cdot R_{acc} = 9.10 \cdot 10^{-3}$)

$$2 \times R_{acc} > R_{min} > 2 \times R_{acc} - 2 \times \sigma_{inj}$$

You keep your job, but no promotion

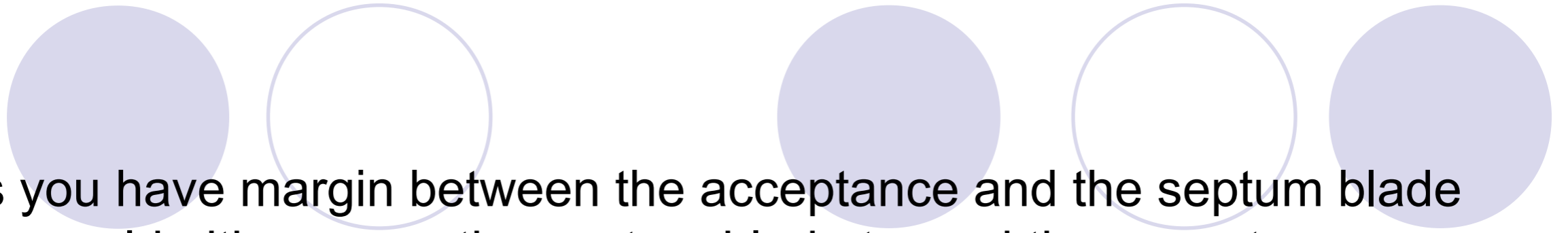

As you have margin between the acceptance and the septum blade you could either move the septum blade toward the acceptance or apply a DC close bump with orbit correctors to reduce R_{min} without reducing the acceptance.

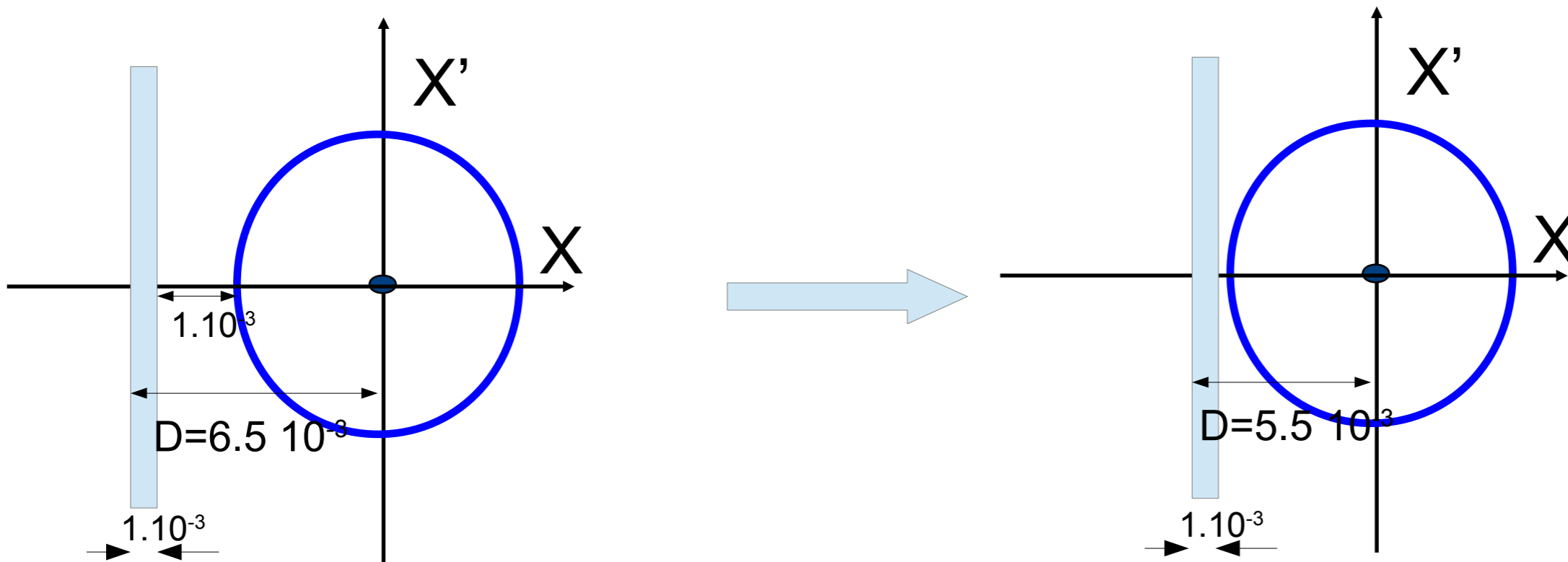

With $D=5.5 \cdot 10^{-3}$, $R_{min}=6.61 \cdot 10^{-3}$
 Finally $R_{min}+2 \cdot \sigma_{inj} < 2 \cdot R_{acc}$

Congratulation !!!