

# Detector Simulation Introduction

Witek Pokorski  
Alberto Ribon  
CERN

08-09.02.2016



# Content

- Introduction to Monte Carlo methods and to Geant4 toolkit
- Geant4 toolkit architecture and physics
- Building a concrete Geant4 application

# Introduction to Monte Carlo methods

- What problems do we face?
- What is simulation?
- Why do we need Monte Carlo?

# Problems

- to design the apparatus (detector) to fulfil its role
- to run it according to our needs
- to understand the results
- to observe new phenomena

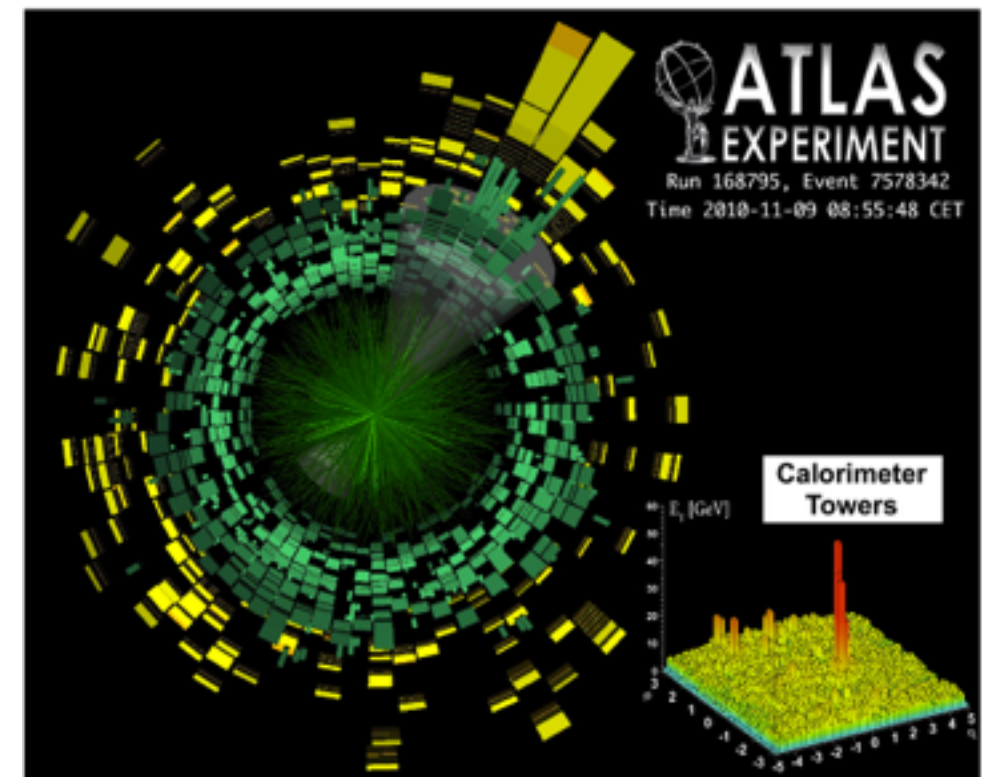

# Solution

- SIMULATION
  - we need to simulate the detector before we build it
  - we need to simulate it when we run it
  - we need to simulate it when we analyse results

# What is simulation

- simulation = doing 'virtual' experiment
- take all the know physics
- start from your 'initial condition' (two protons colliding)
- calculate the 'final state' of your detector to get the 'experimental' results
  - solve equations of motion, etc
- **IMPOSSIBLE** to be done analytically

# Way to do it: Monte Carlo

- analytical solutions impossible due to
  - complexity of the problem
    - number of particles, etc
  - lack of analytical description
  - need of randomness like in nature
    - to pick among possible choices
      - quantum mechanics, fluctuations
  - ... because Einstein was wrong: God does throw dice!
    - Quantum mechanics amplitudes = probabilities. Anything that possibly can happen, will. (but more or less often)



# Monte Carlo method

- repeated random sampling to find the result
- used for
  - numerical integration
  - generation of samples from probability distribution
  - optimisation
  - etc





# Example: $\pi$ 'calculation'

## Buffon's needle

- we throw needles of length  $L$  on the floor made of parallel stripes of wood of width  $t$
- we count those crossing the vertical lines

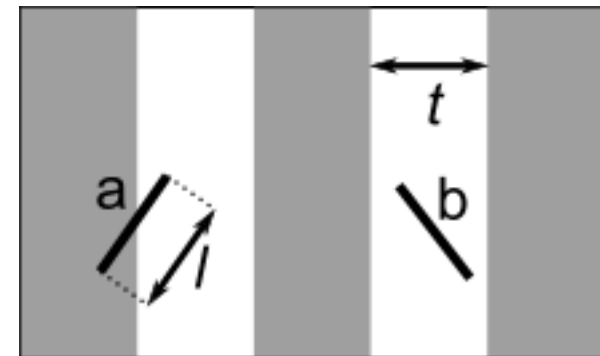

$$\pi \approx \frac{2l \cdot n}{th}$$

we drop  $n$  needles and find that  $h$  of those needles are crossing lines

# Monte Carlo in HEP

- Simulation is an essential tool in modern particle physics for:

- prediction event rates and topologies

- can estimate feasibility

- evaluation of possible backgrounds

- can devise analysis strategies

- study detector requirements

- optimisation detector/trigger design

- studying detector imperfections

- can evaluate acceptance corrections

- analysing the data

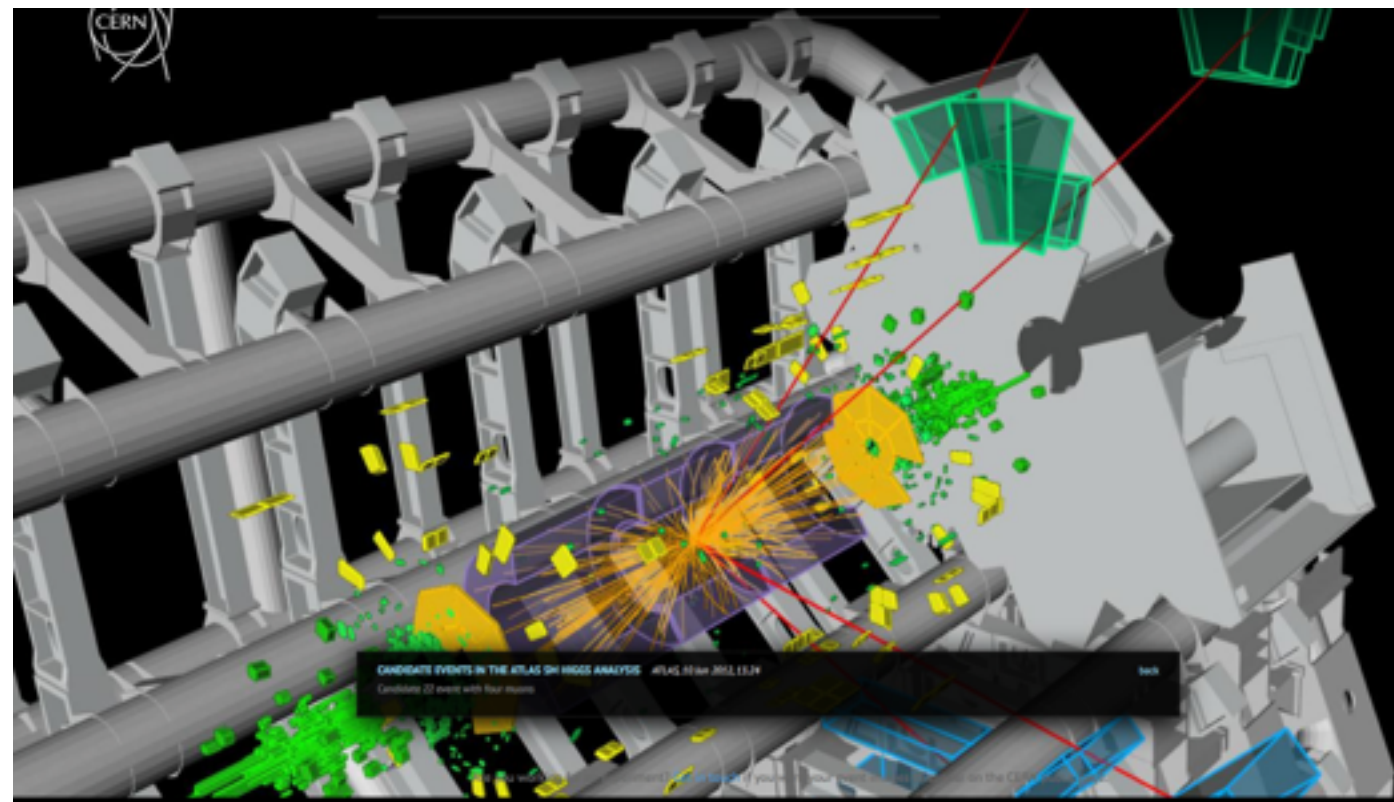

# Monte Carlo in LHC experiments

- For the LHC experiments, the simulation is made of two distinct steps:

1. Simulation of the p-p collision

- Monte Carlo event generators

2. Simulation of the passage of the produced particles through the experimental apparatus

- Monte Carlo radiation transportation, or simply “detector simulation”

- The output of 1. is the input of 2.



# Monte Carlo radiation transportation codes

- The simulation of the p-p collision is the same for different experiments at the same collider, e.g. ATLAS and CMS
- The detector simulation is different for each experiment. However, [general codes exist that can be used for simulating any detector](#)
  - An experimental apparatus can be modelled in terms of [elementary geometrical objects](#)
  - The [physics processes](#) are detector independent
- These general codes, e.g. Geant4, are called “[Monte Carlo radiation transportation codes](#)”
  - Non-deterministic (e.g. do not solve equations); use random numbers to reproduce distributions
  - Transport particles through matter

# Simulation chain for HEP experiment

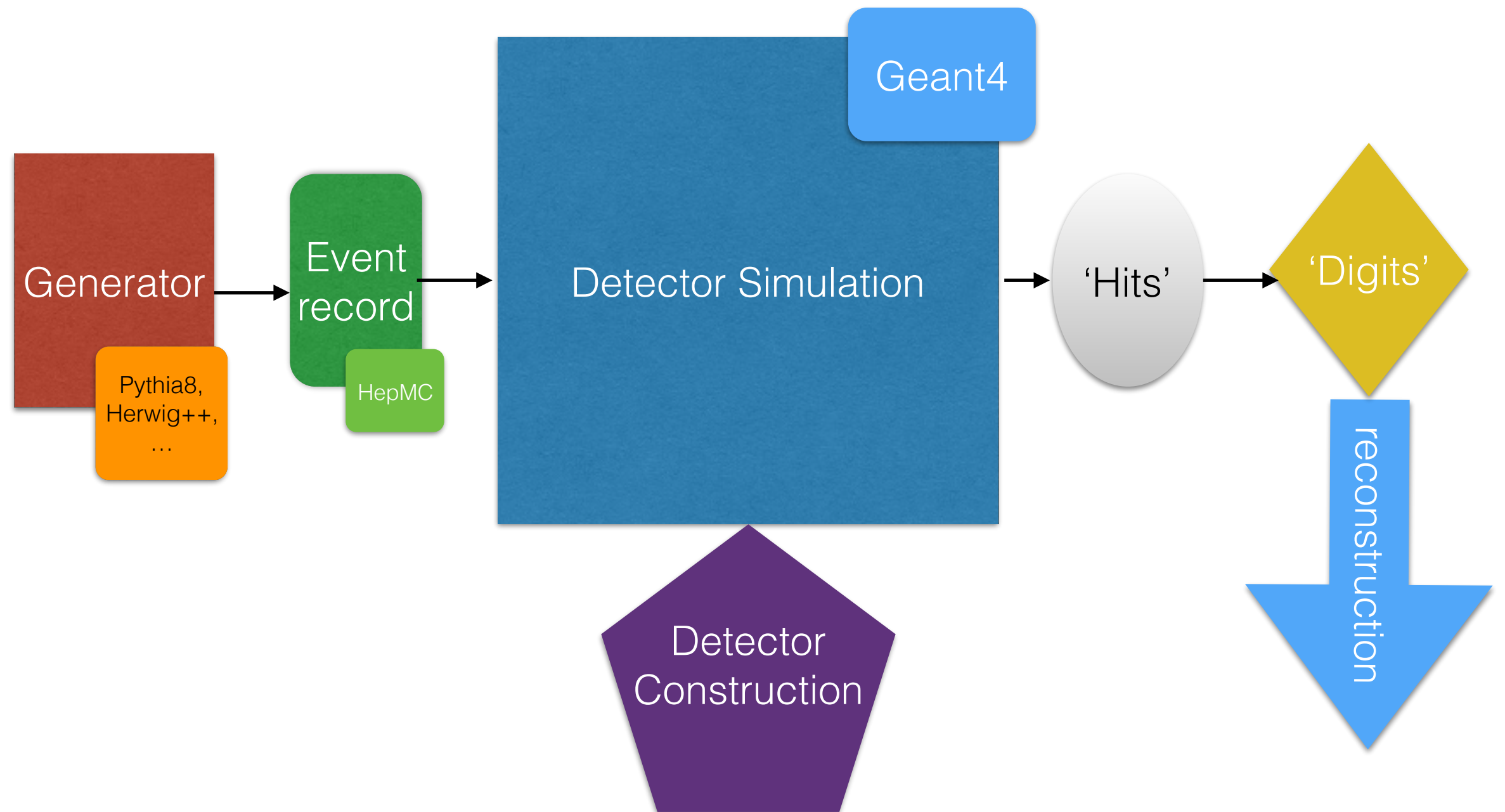

# How does detector simulation work?

- Treat one particle at the time
- Treat a particle in steps
- For each step

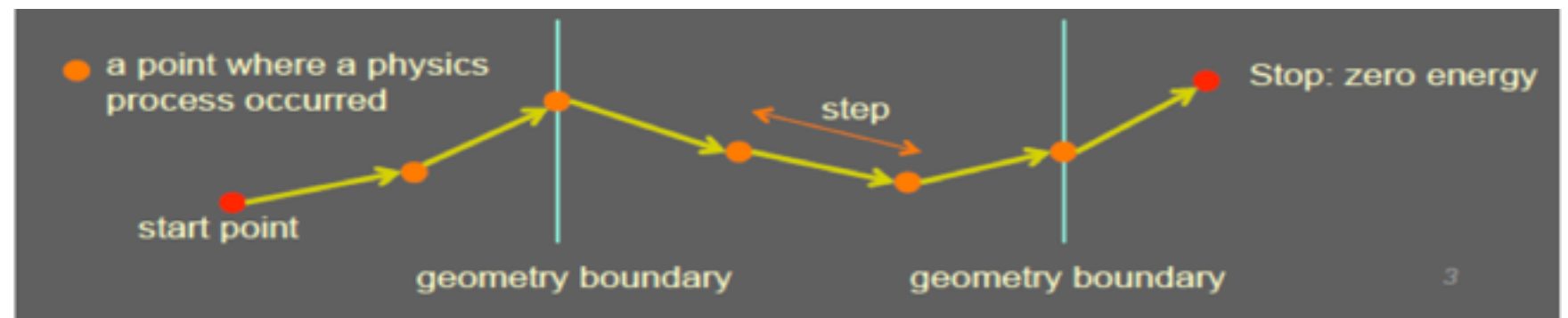

- the step length is determined by the cross sections of the physics processes and the geometrical boundaries; if new particles are created, add them to the list of particles to be transported;
  - local energy deposit; effect of magnetic and electric fields;
  - if the particle is destroyed by the interaction, or it reaches the end of the apparatus, or its energy is below a (tracking) threshold, then the simulation of this particle is over; else continue with another step.
- Output
    - new particles created (indirect)
    - local energy deposits throughout the detector (direct)



# Algorithm

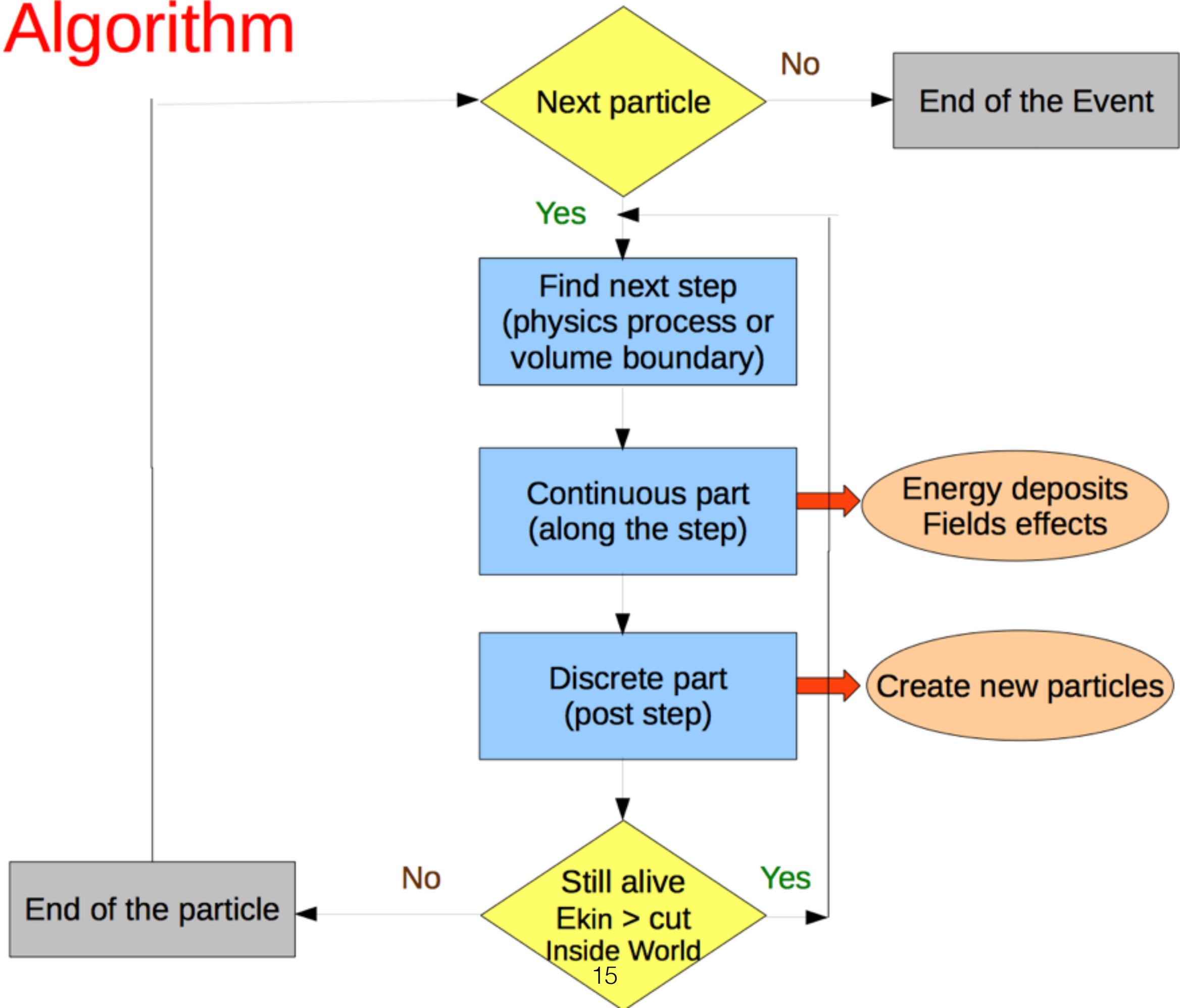

# Digitization

- Besides the geometry, another experiment-specific aspect of the detector simulation is the “digitization”
  - It is not part of the general radiation transportation codes
- It consists of producing the detector response in terms of **electric current & voltage signals**, as it would happen in the real experiment
  - The same reconstruction chain can be applied for both real and simulated data
- The general radiation transportation code provides **energy deposits** in the whole detector; from these, the “digitization” simulates the **electrical signals** induced in the **sensitive parts** of the detector



# Accuracy vs speed

- Huge samples (billions) of simulated events are needed by the experiments for their physics analyses
- The number of simulated events is **limited by CPU**
- The simulation time is **dominated by the detector simulation**
- **Tradeoff between accuracy and speed** of the detector simulation
  - More precise physics models are slower and, more importantly, create more secondaries and/or steps
  - Smaller geometrical details slow down the simulation
    - Never model explicitly screws, bolts, cables, etc.
  - Continuous spectrum of types of detector simulations:
    - From full, detailed detector simulations
    - To very fast, fully parametrized detector simulations

# Application domains

- We are considering here mainly high-energy physics, but... There are other domains where the same radiation transportation codes are successfully used:
  - Nuclear physics
  - Accelerator science
  - Astrophysics
  - Space engineering
  - Radiation damage
  - Medical physics
  - Industrial applications
- So, detector simulation is a multi-disciplinary field!

# Monte Carlo toolkits

- Geant4 (Geant3)
- FLUKA
- MCNP, MCNPX
- MARS
- GeantV - ongoing effort to explore parallelism and vectorisation

# What is Geant4?

- A software (C++) toolkit for the Monte Carlo simulation of the passage of particles through matter
  - 'propagates' particles through geometrical structures of materials, including magnetic field
  - simulates processes the particles undergo
    - creates secondary particles
    - decays particles
  - calculates the deposited energy along the trajectories and allows to store the information for further processing ('hits')

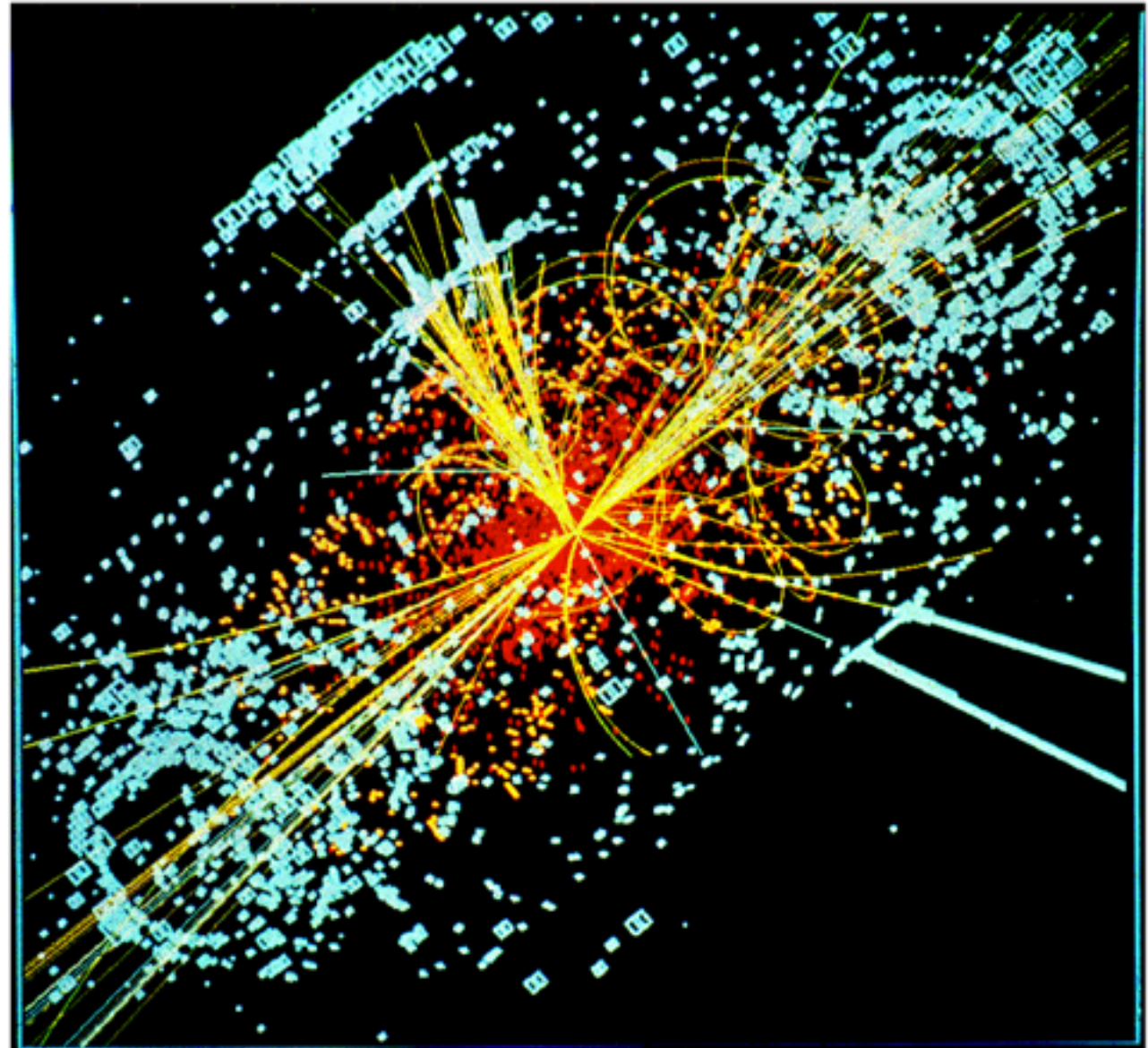

Simulated Higgs event in CMS

# Geant4 has been successfully employed for

- Detector design
- Calibration / alignment
- First analyses

T. LeCompte (ANL)

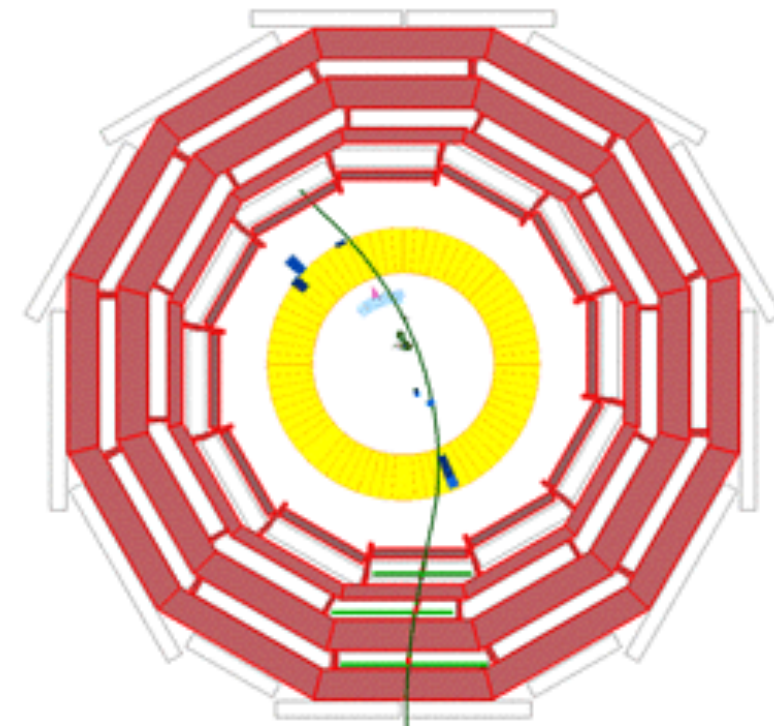

## GEANT4 Comparisons with the Calorimeters

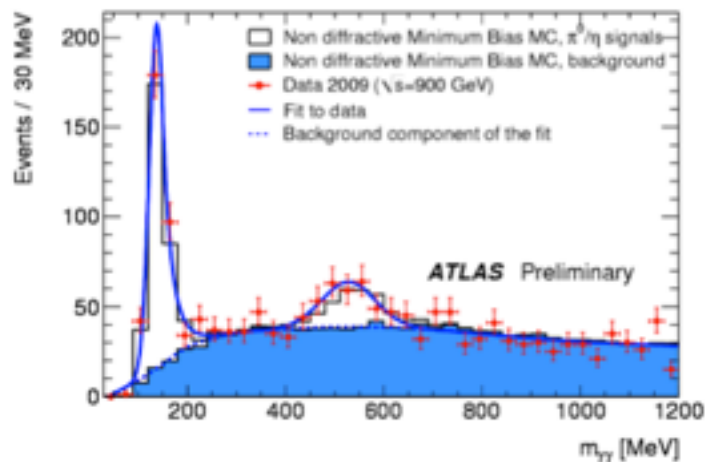

Invariant mass of pairs of well-isolated electromagnetic clusters.

The  $\pi^0$  mass is within  $0.8 \pm 0.6\%$  of expectations.

The  $\eta^0$  mass is within  $3 \pm 2\%$  of expectations.

The detector uniformity is better than 2%.

Response of the calorimeter to single isolated tracks. To reduce the effect of noise, topological clusters are used in summing the energy.

This plot agreed better than we ever expected. (I sent the student who made it back to make sure that they didn't accidentally compare G4 with G4.)

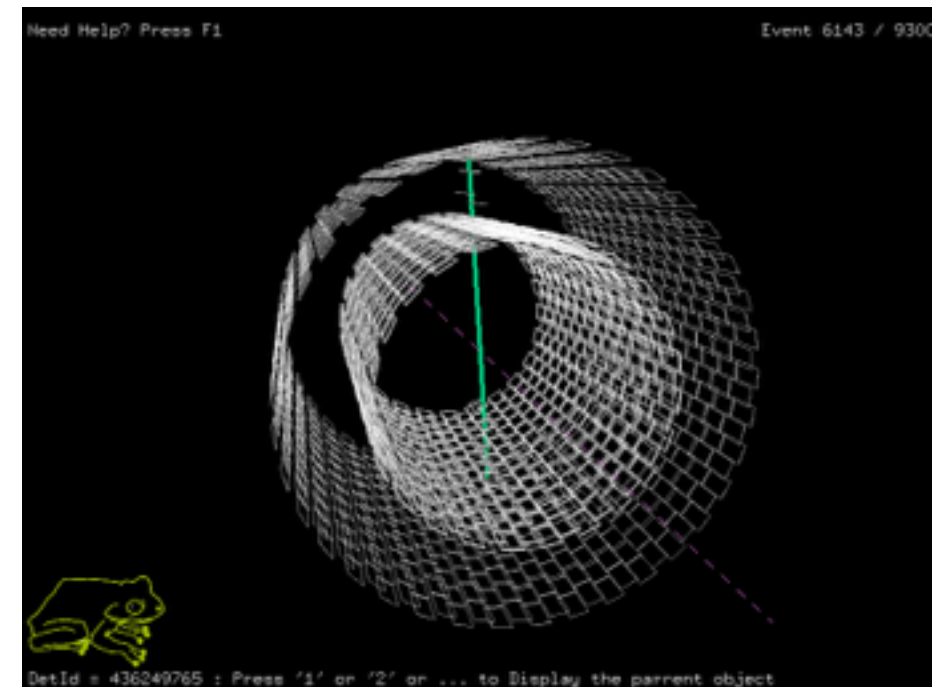
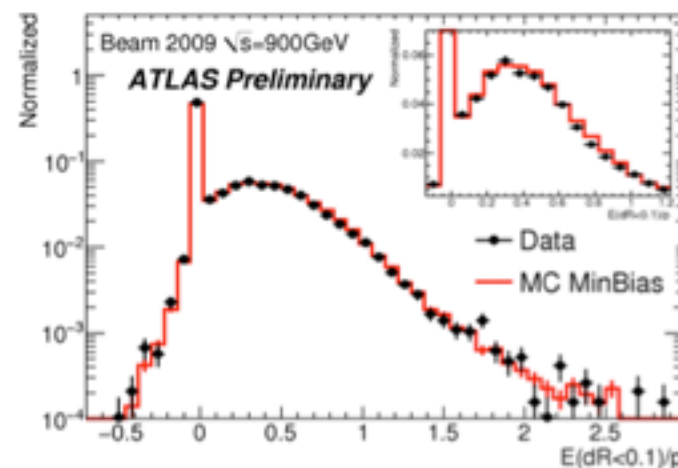

Figures from CMS



# Missing $E_T$

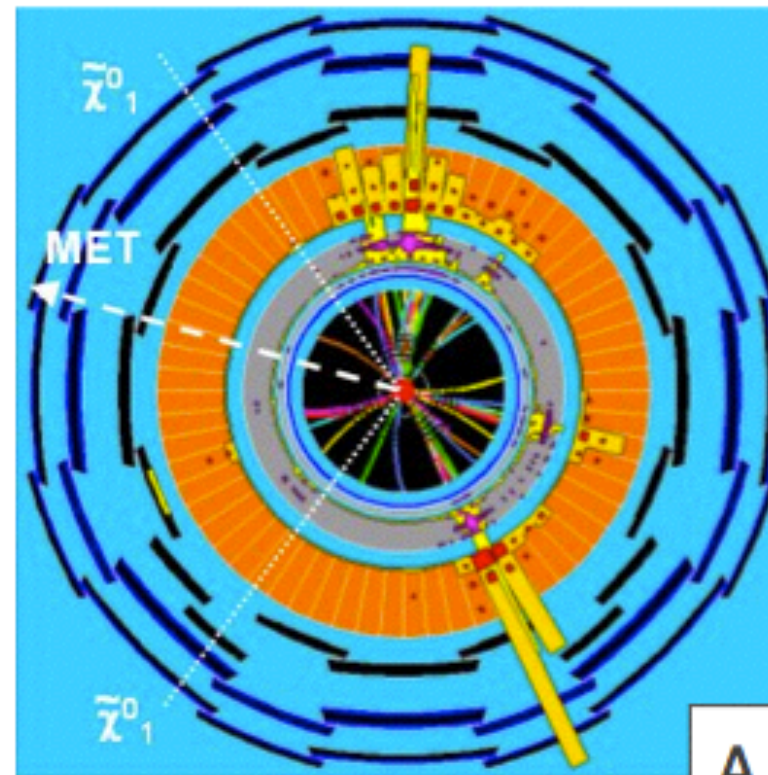
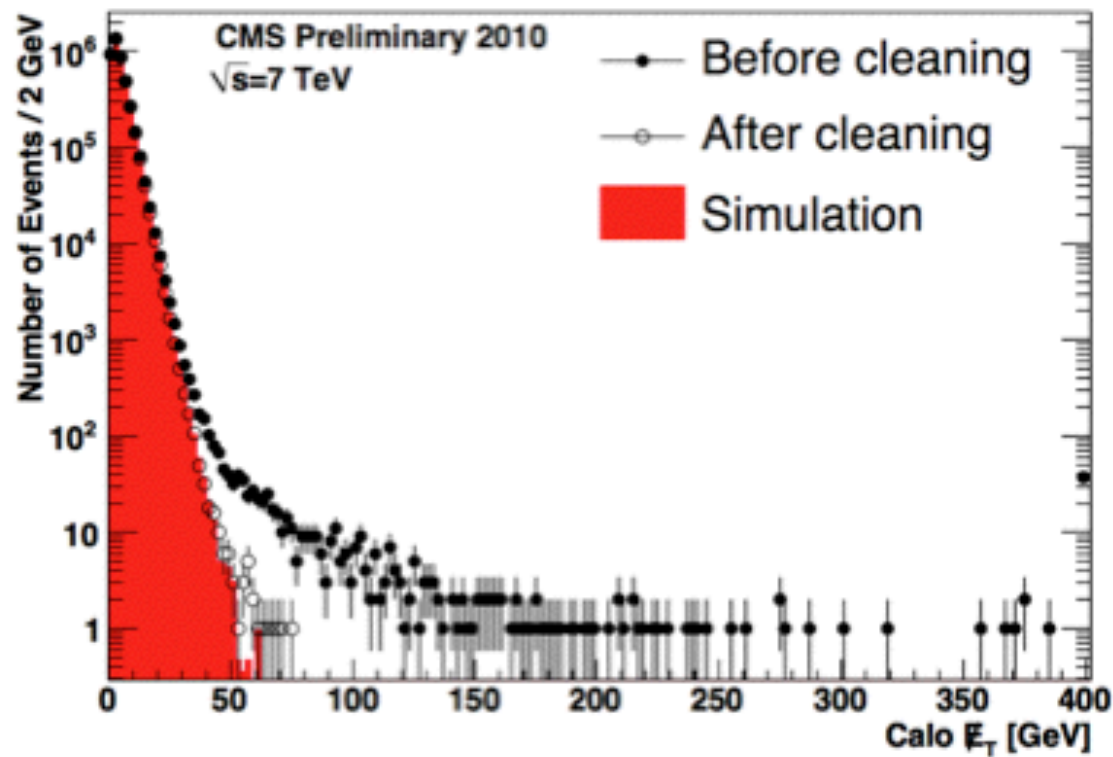
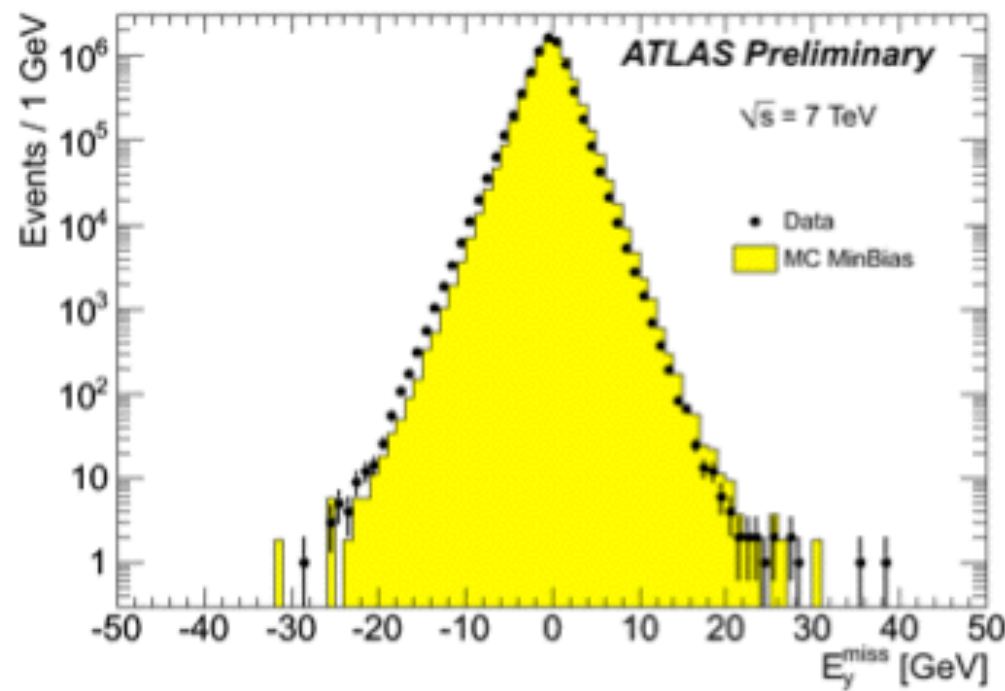
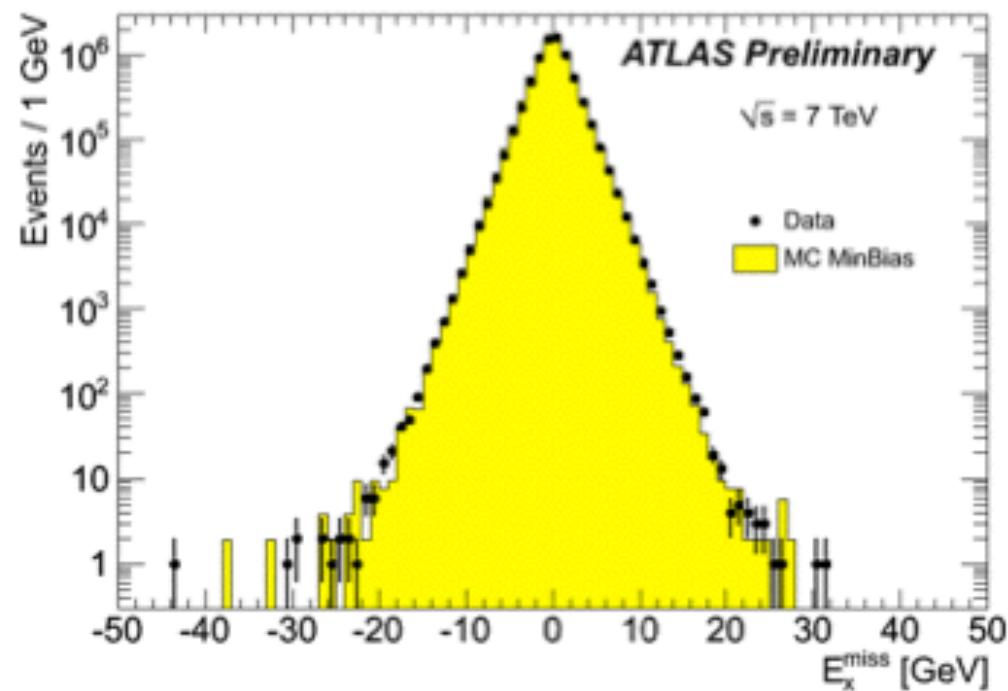

A GEANT4 event.

This is one of the hardest things to get right. MET incorporates everything measured in the detector and attempts to identify non-interacting particles, such as neutrinos or dark matter.

Agreement is astounding.

You can even see that the ATLAS detector is not quite centered – in both data and MC.

Both ATLAS and CMS plots are made from a tiny piece of the very earliest data.

T. LeCompte (ANL)

# Simulation is needed to make discoveries

- We need to understand the detector to do physics
- We need to know what to expect to
  - verify existing models
  - find new physics

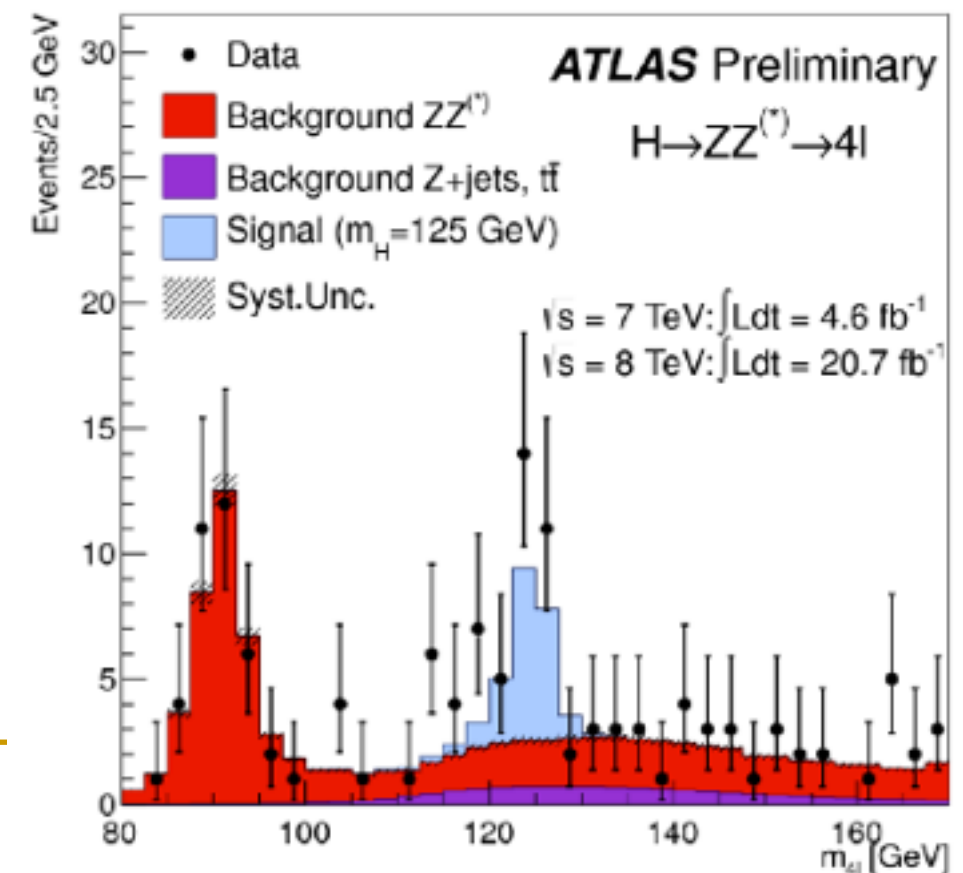
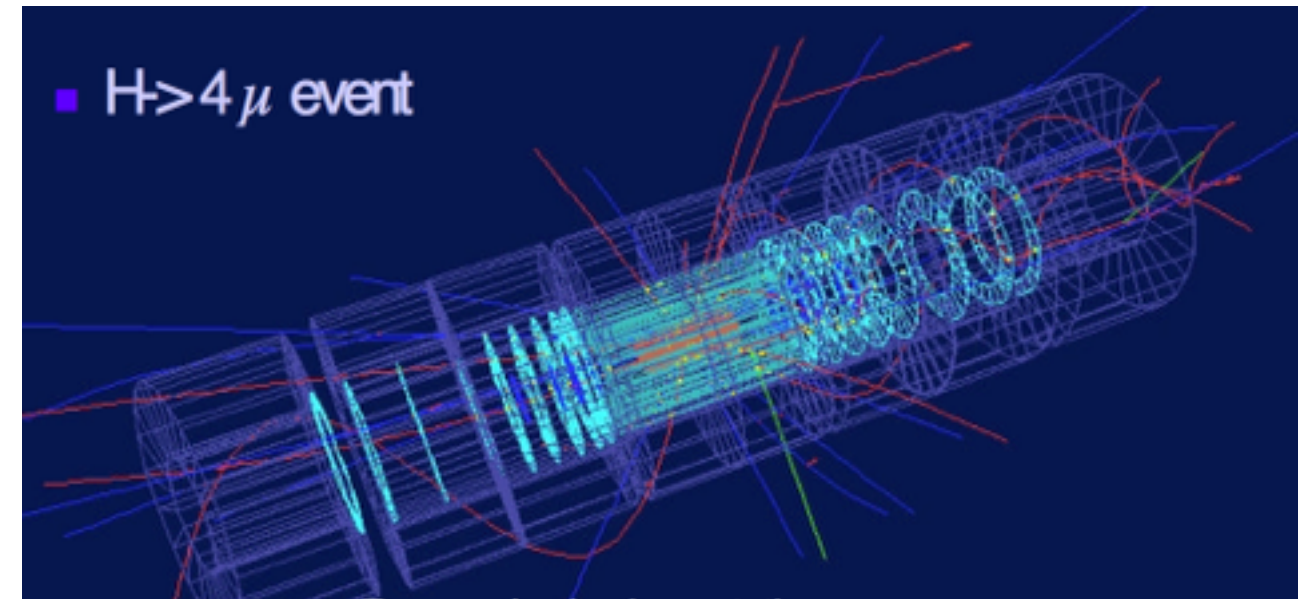



# Geant4 in High Energy Physics (ATLAS at LHC)

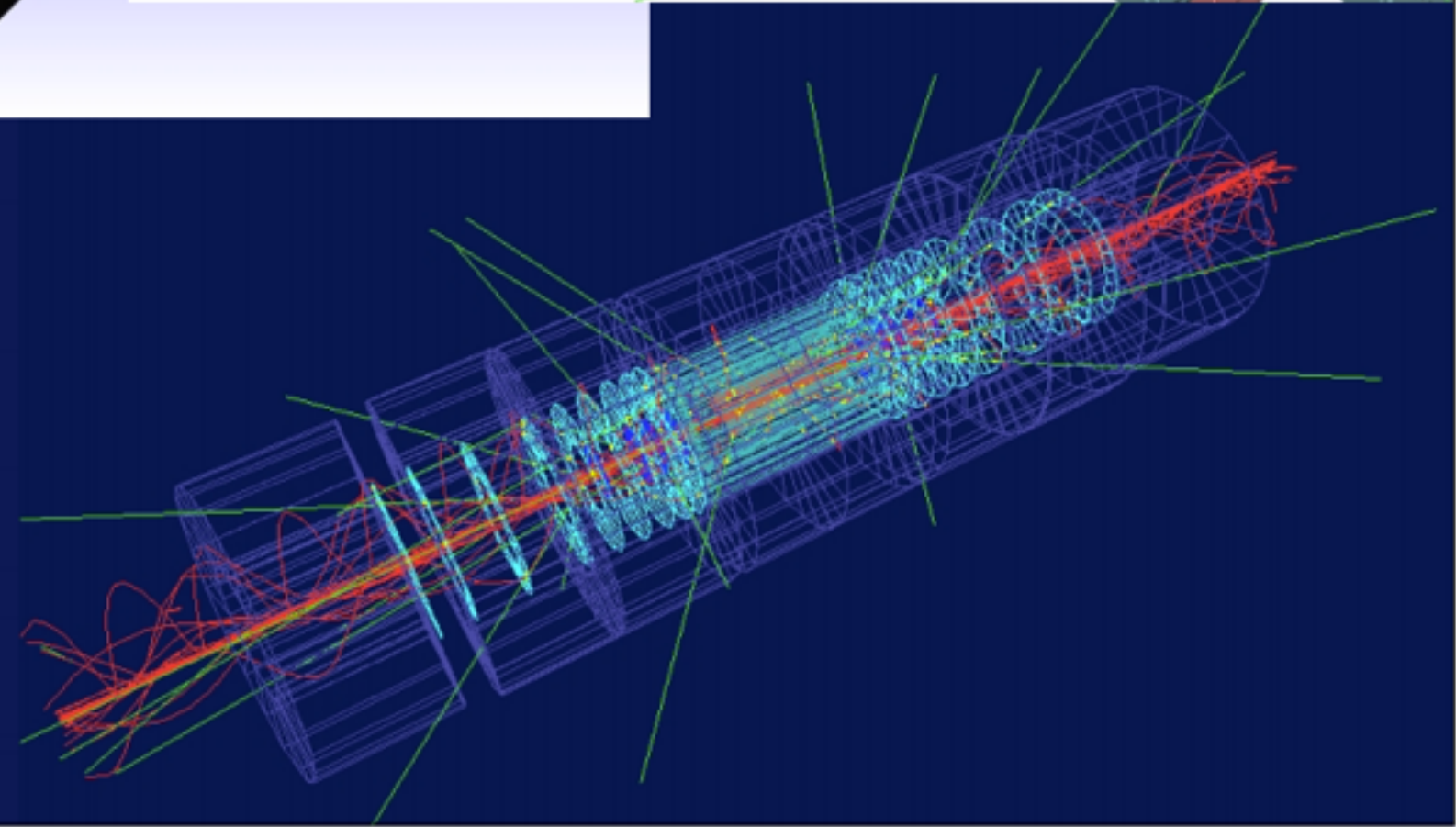
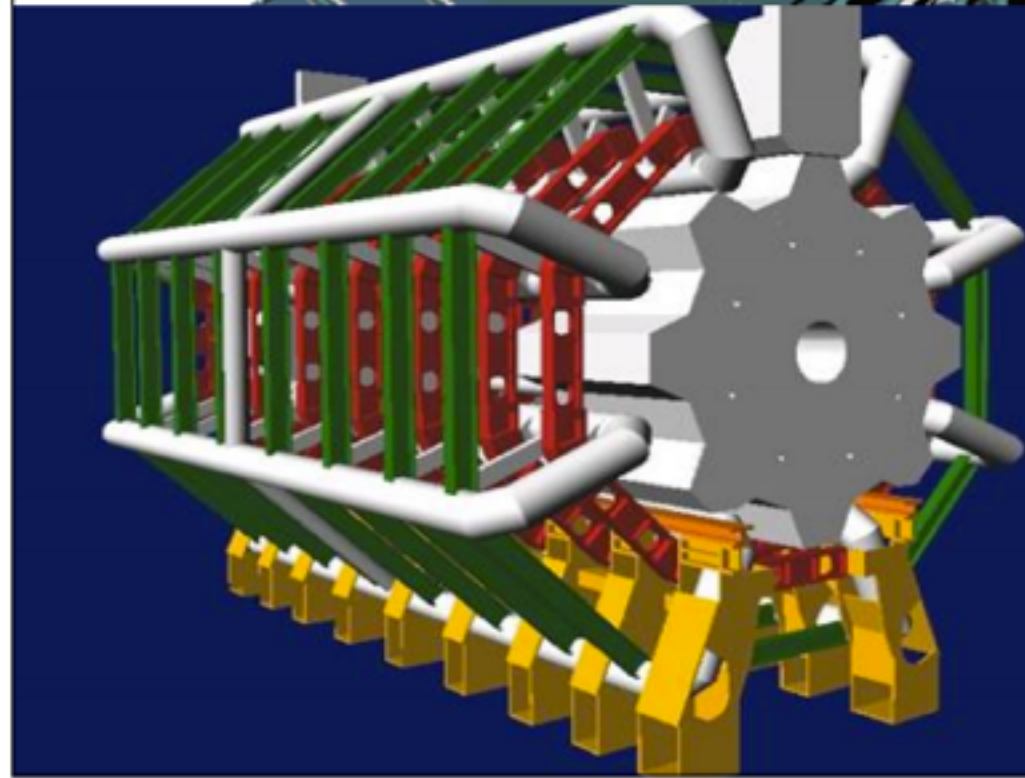
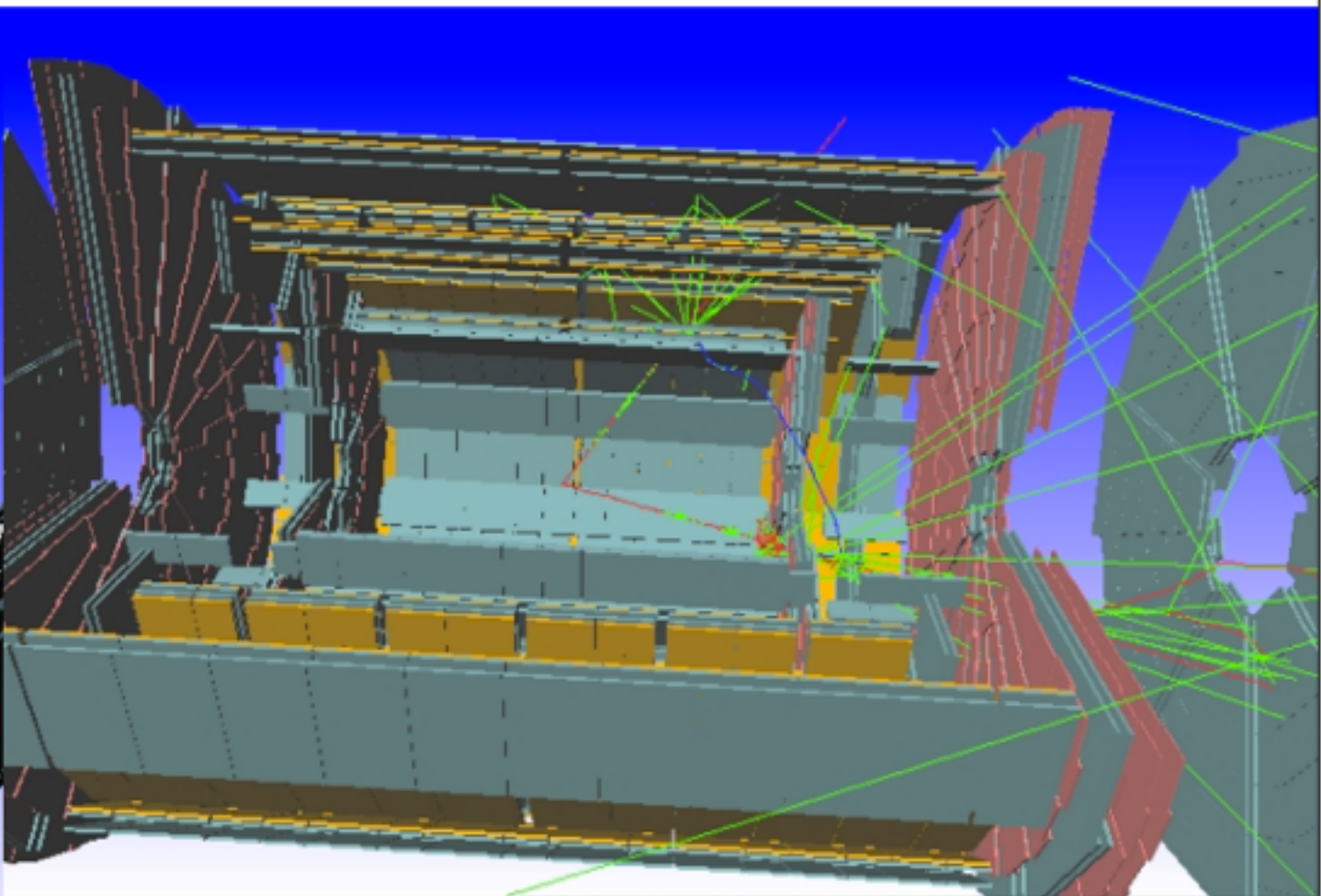
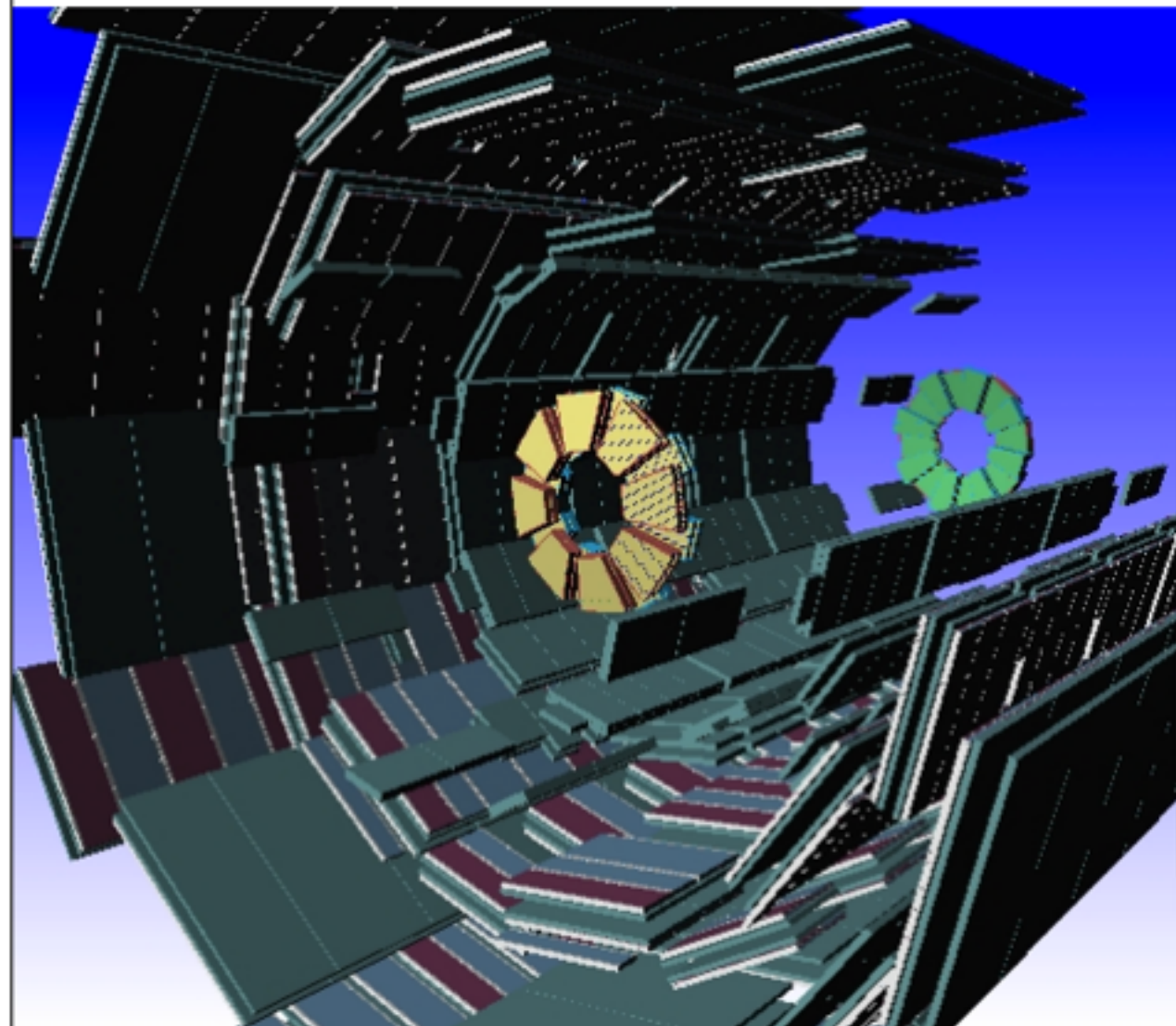



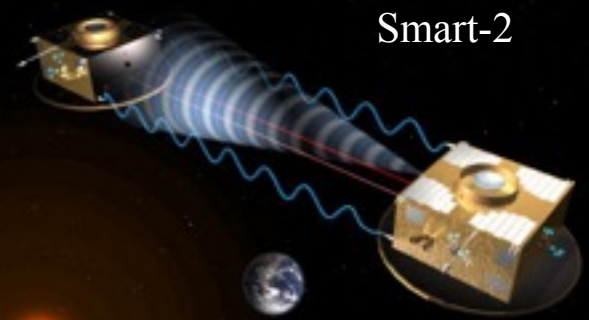

Smart-2

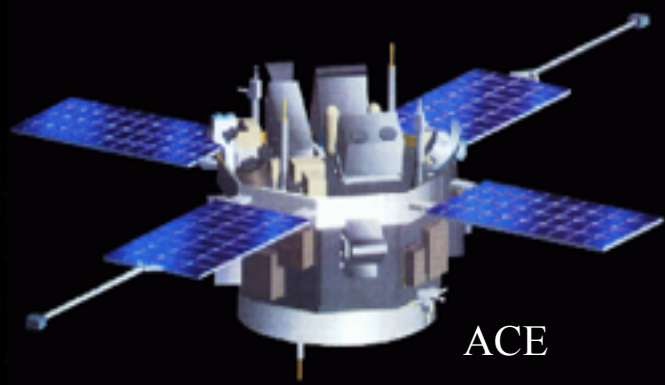

ACE

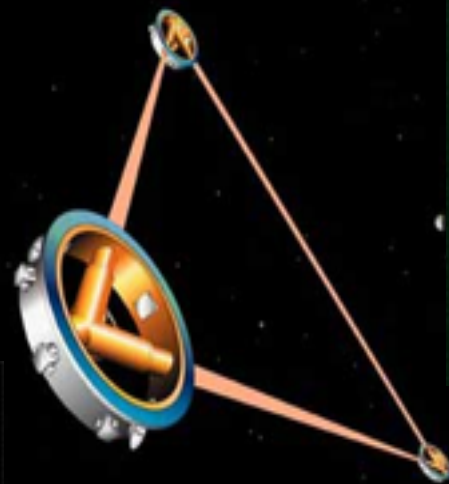

LISA

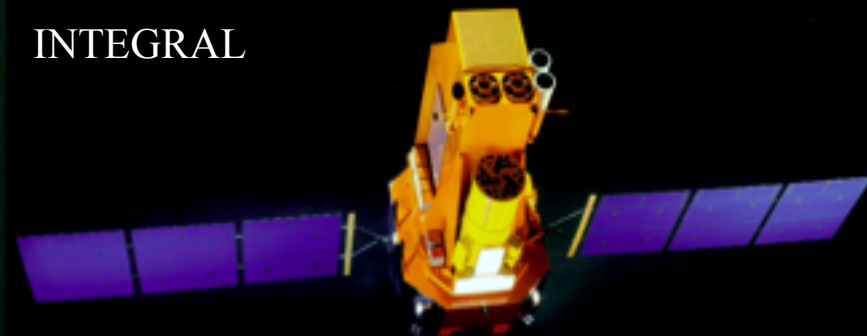

INTEGRAL

Cassini



Bepi Colombo

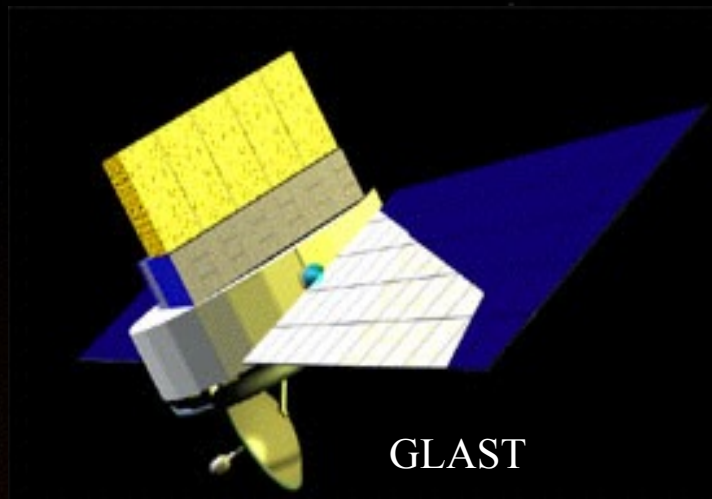

GLAST

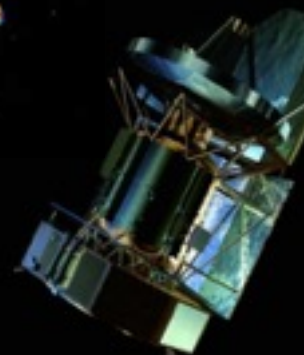

Herschel



SWIFT



Astro-E2



XMM-Newton

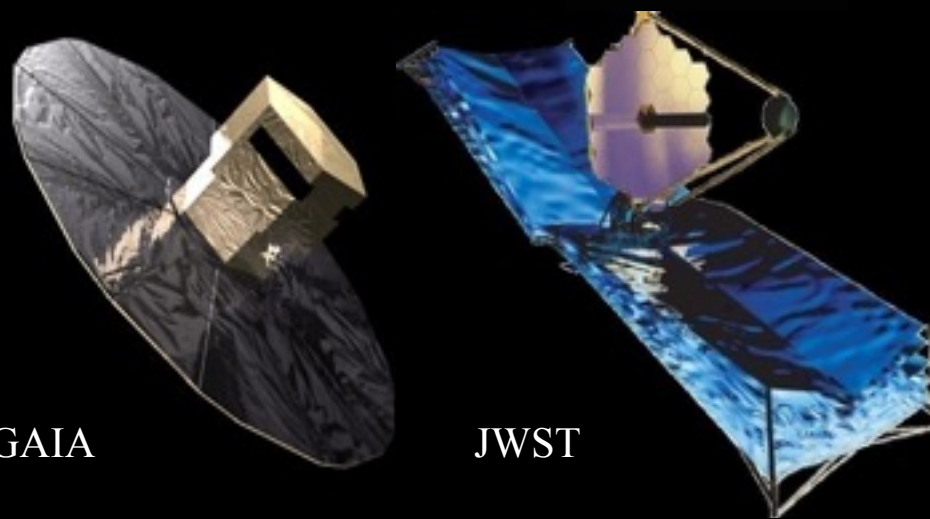

GAIA

JWST

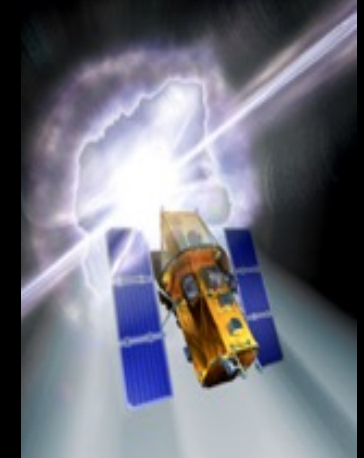

ISS Columbus

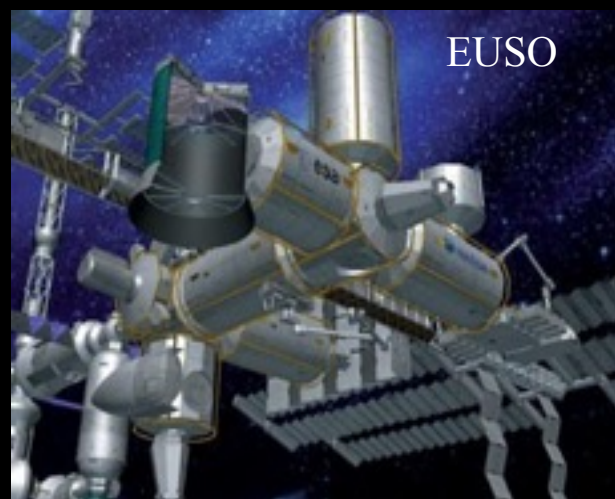

EUSO

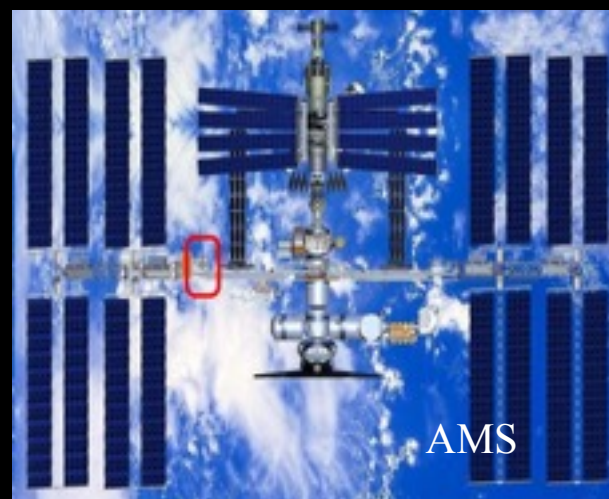

AMS

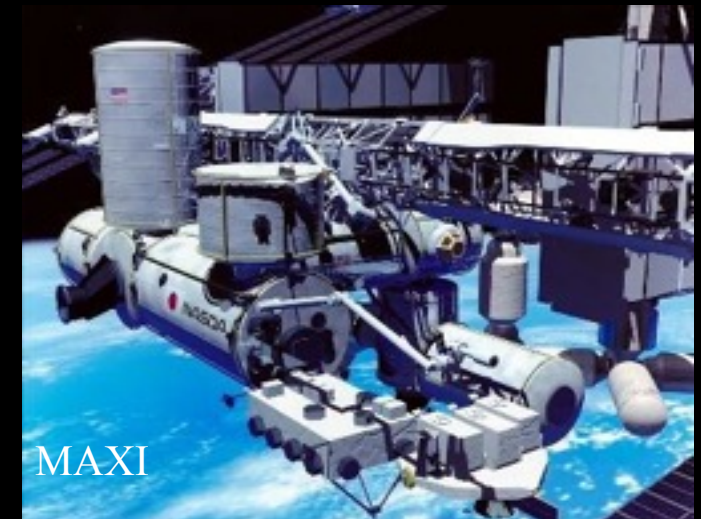

MAXI



# RADSAFE on SEE in SRAMs

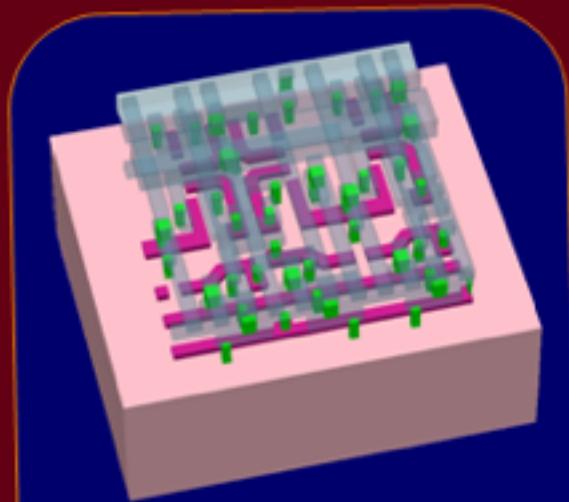

**TCAD Cell Structure: SRAM Cell**

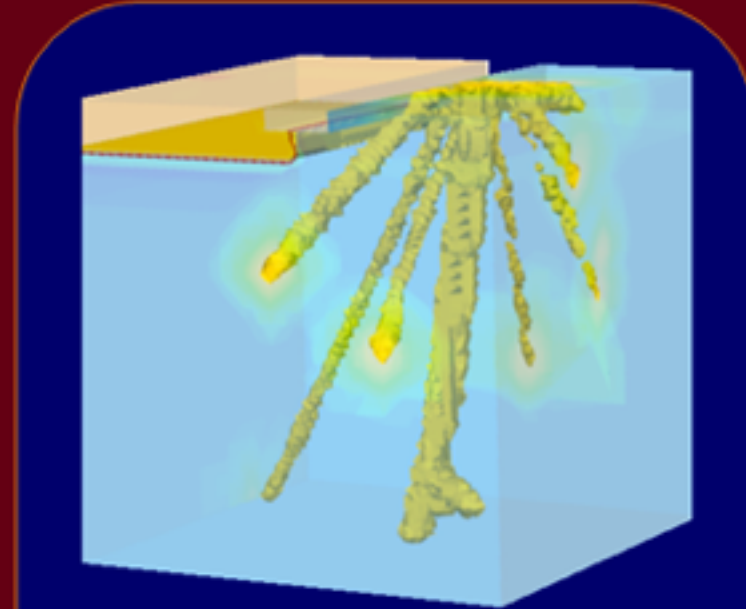

**Single Charge Deposition in TCAD: Ne+W Event**

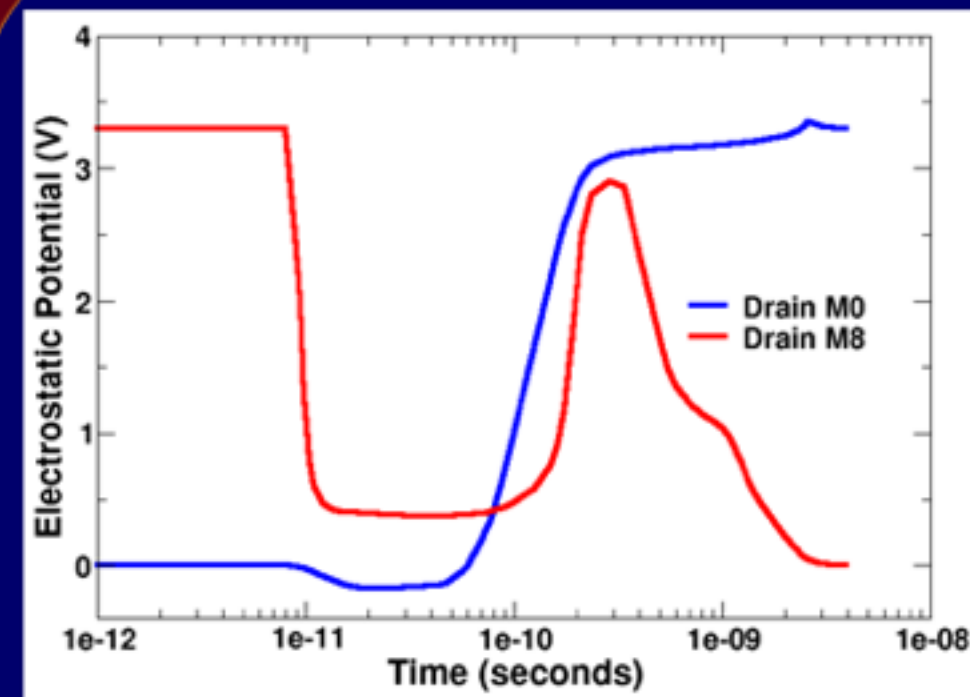

**SRAM Cell Upset**

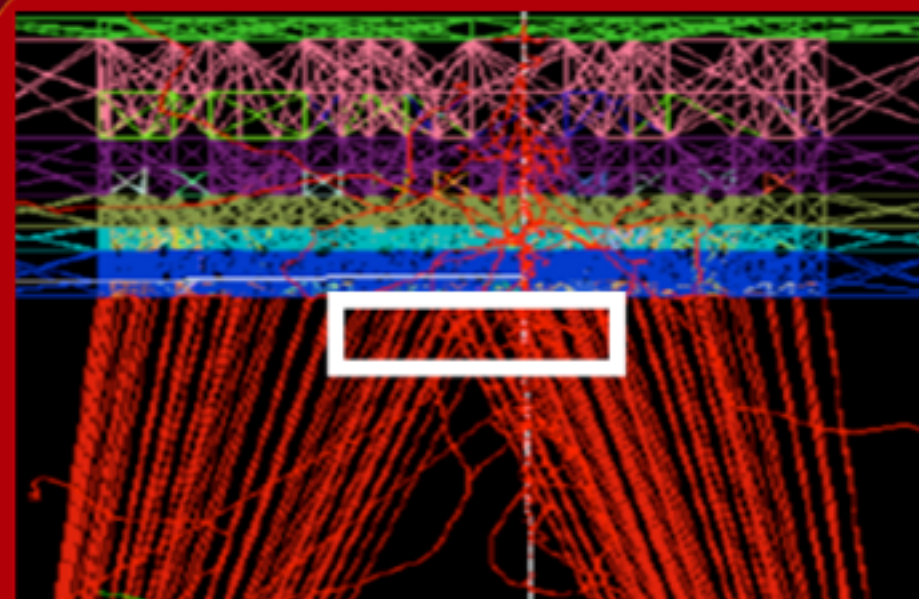

**Geant4 Geometry and 523 MeV Neon Event**

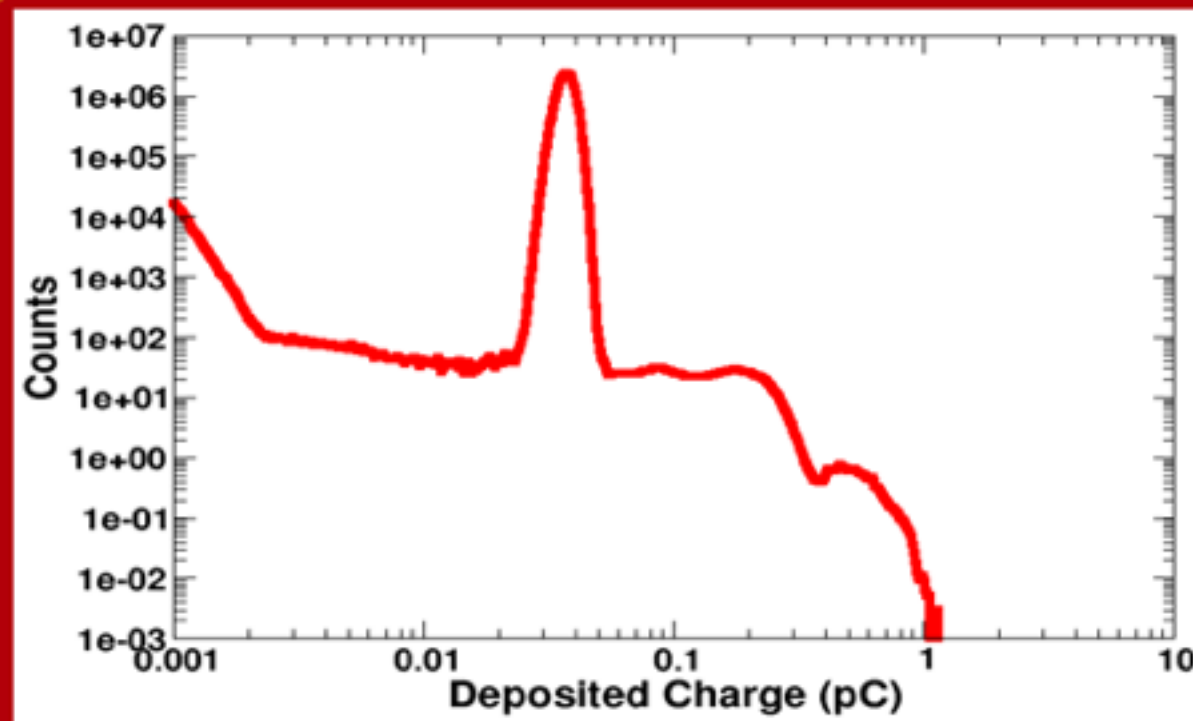

**MRED Energy Deposition for 10<sup>8</sup> Events**



# GEANT4 based proton dose calculation in a clinical environment: technical aspects, strategies and challenges

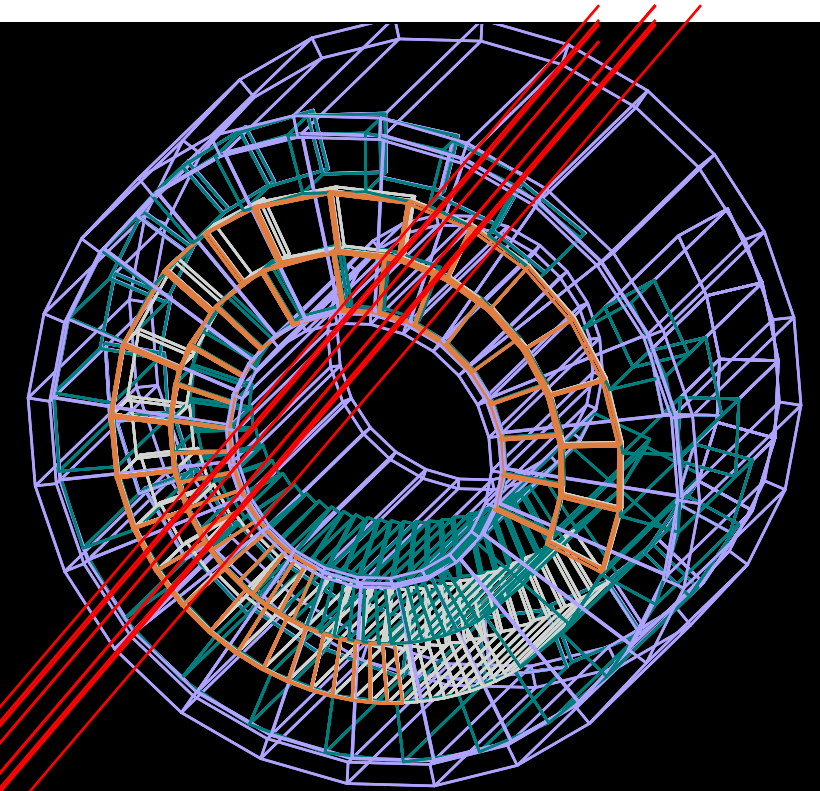
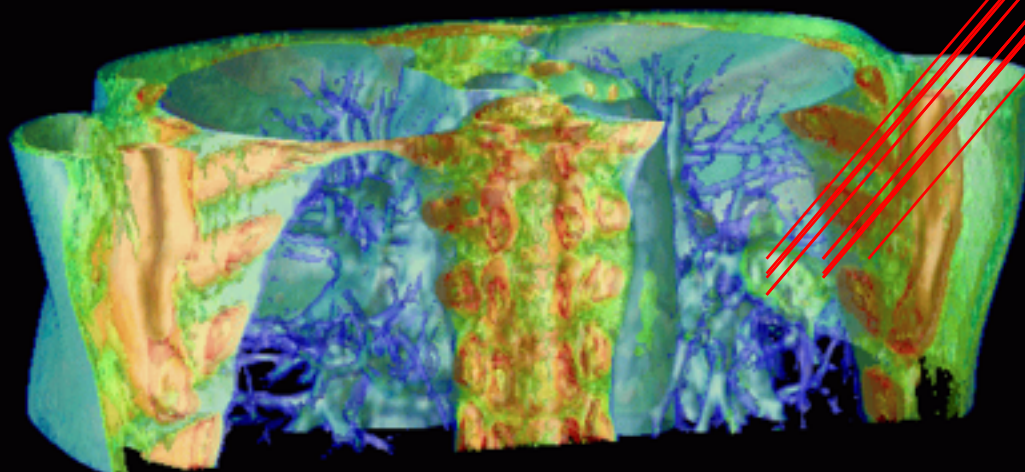
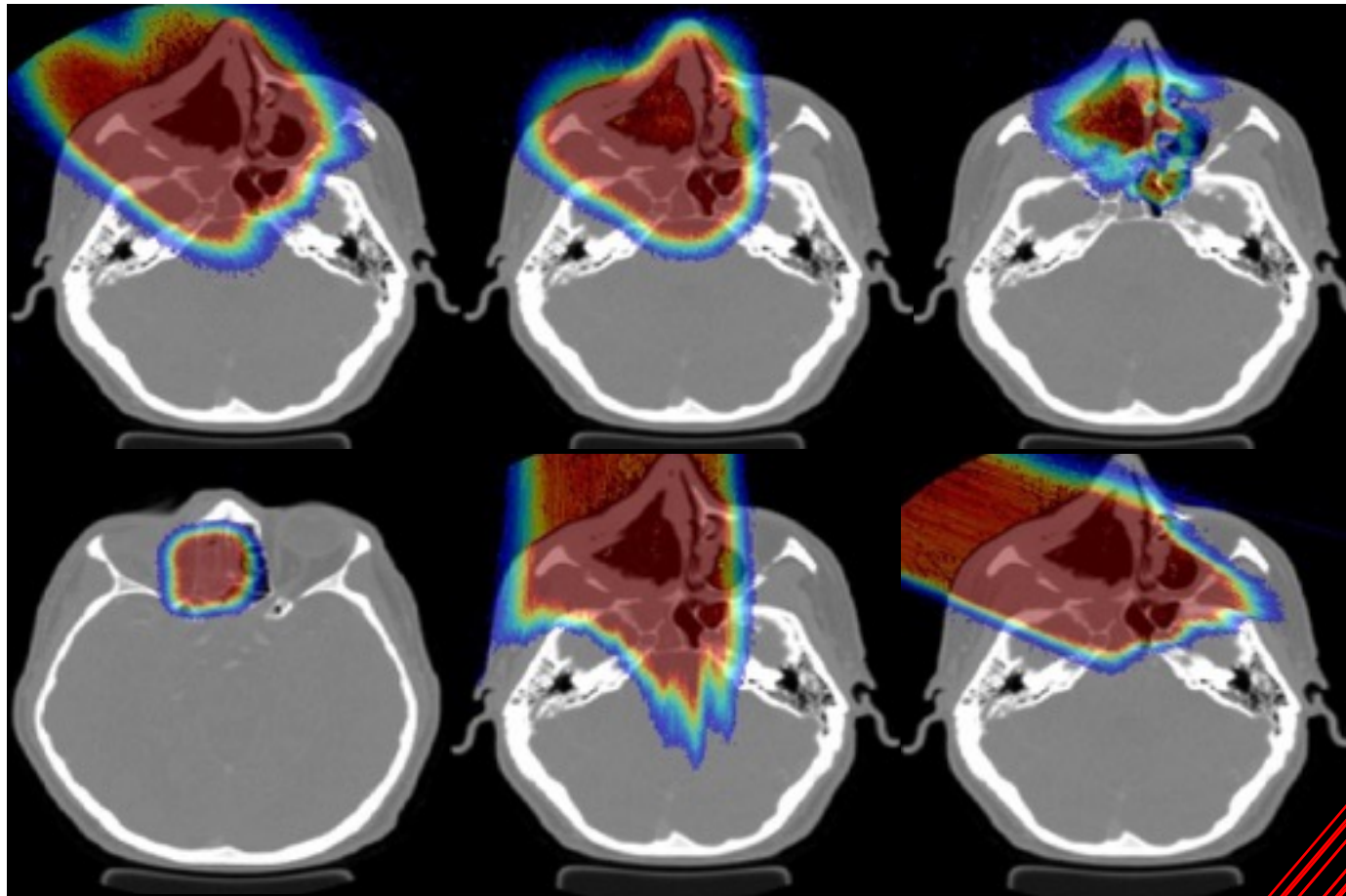

**Harald Paganetti**



MASSACHUSETTS  
GENERAL HOSPITAL

**HARVARD**  
MEDICAL SCHOOL



---

# TOOLKIT ARCHITECTURE

# Geant4 Components

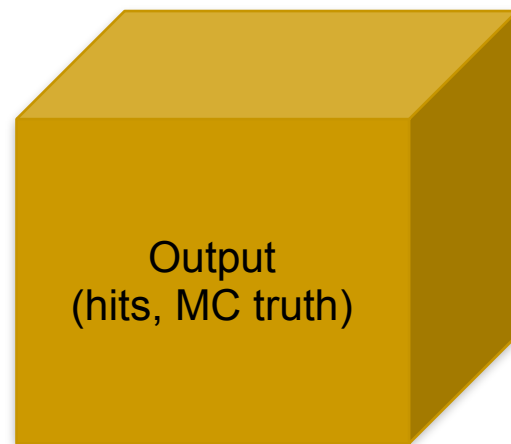
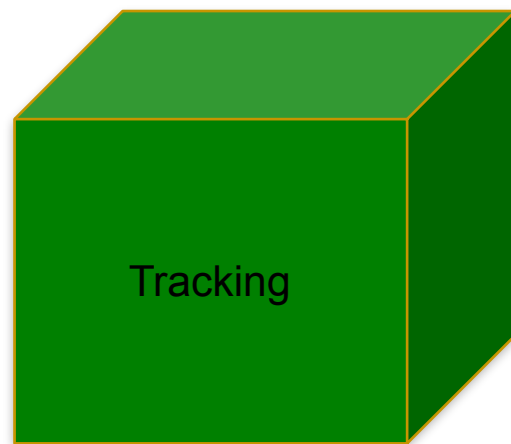
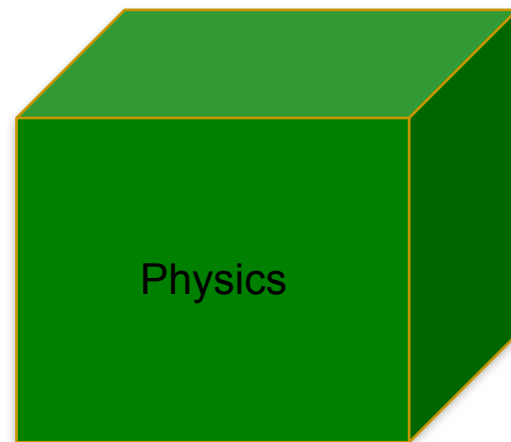
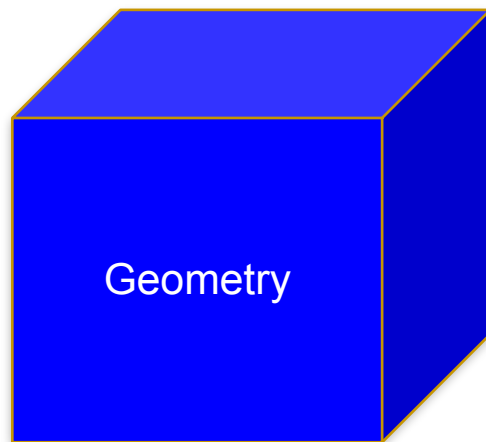

- 'kernel', internals of the engine, no direct interaction with the user code
- 'user interface'
  - classes directly instantiated by the users with specific parameters
    - box of dimension  $x, y, z$
  - base classes for concrete users implementations
    - 'user actions', sensitive detectors

# Geant4 application

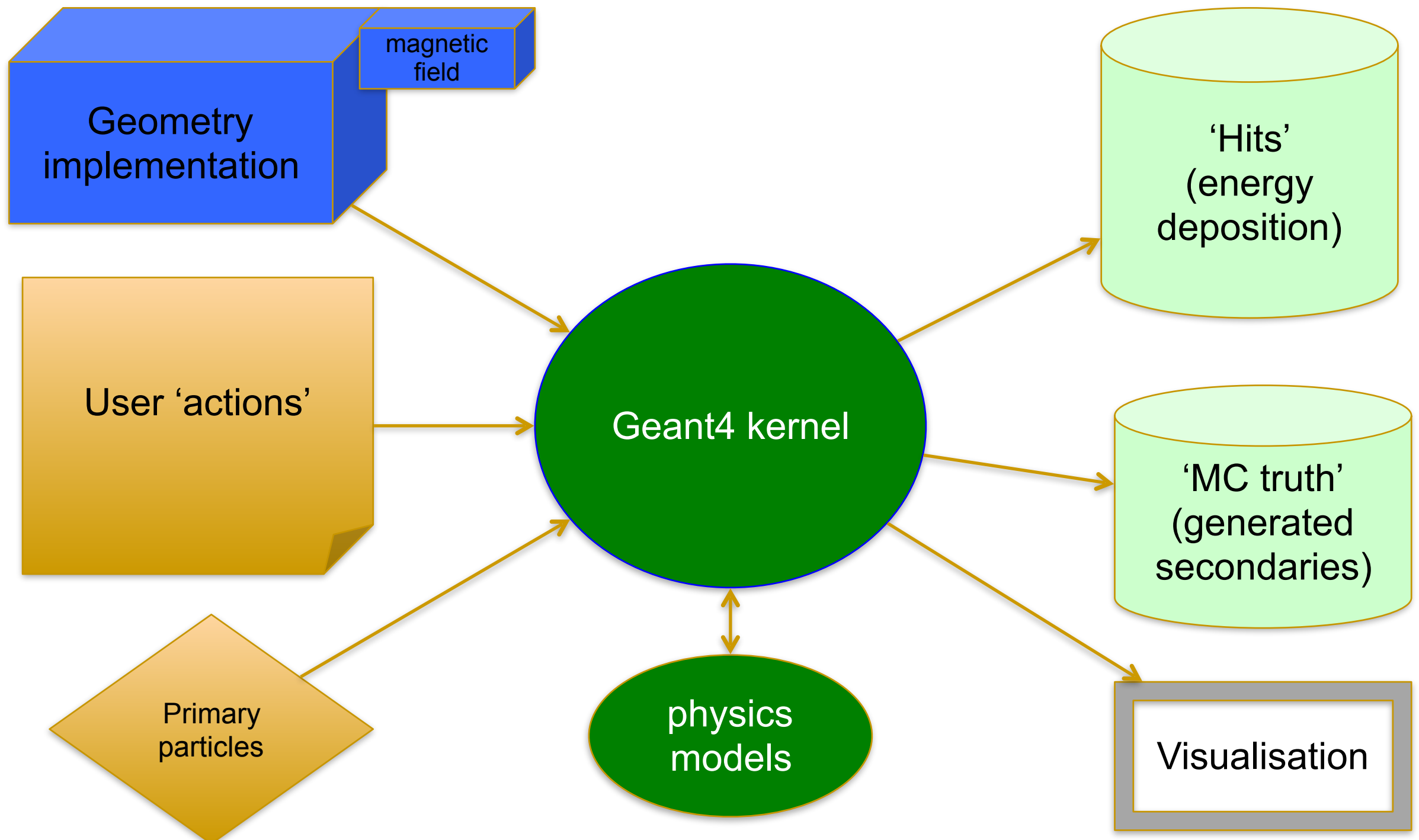



# Geometry

- how to implement (efficiently) this in your computer program?
  - you need ‘bricks’
    - ‘solids’, ‘shapes’
    - you need to position them
    - you want to ‘reuse’ as much as possible the same ‘templates’

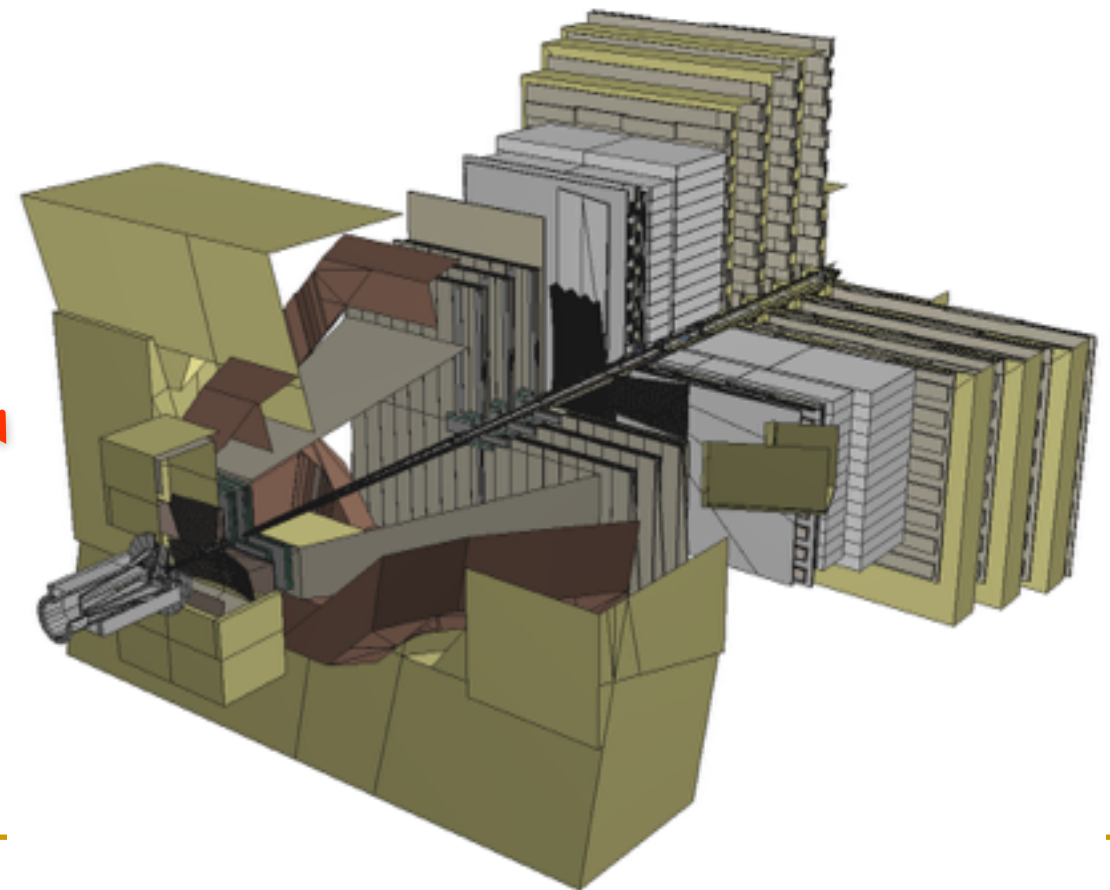
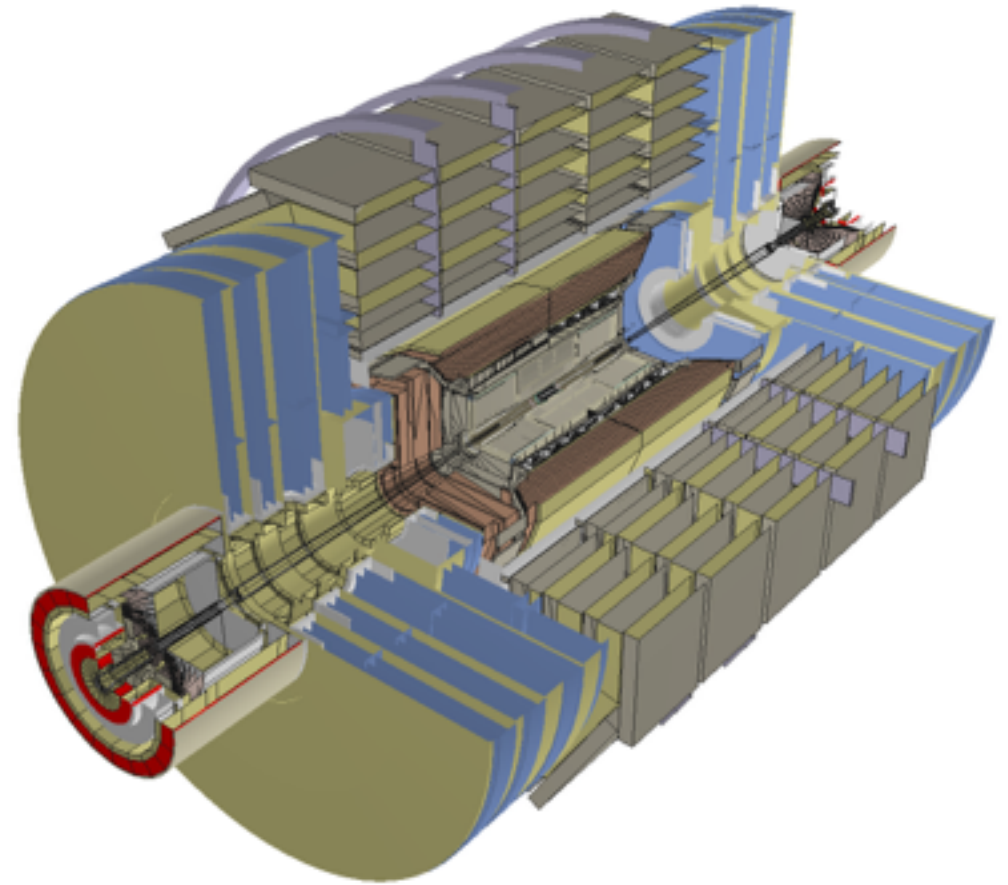

# Geometry construction

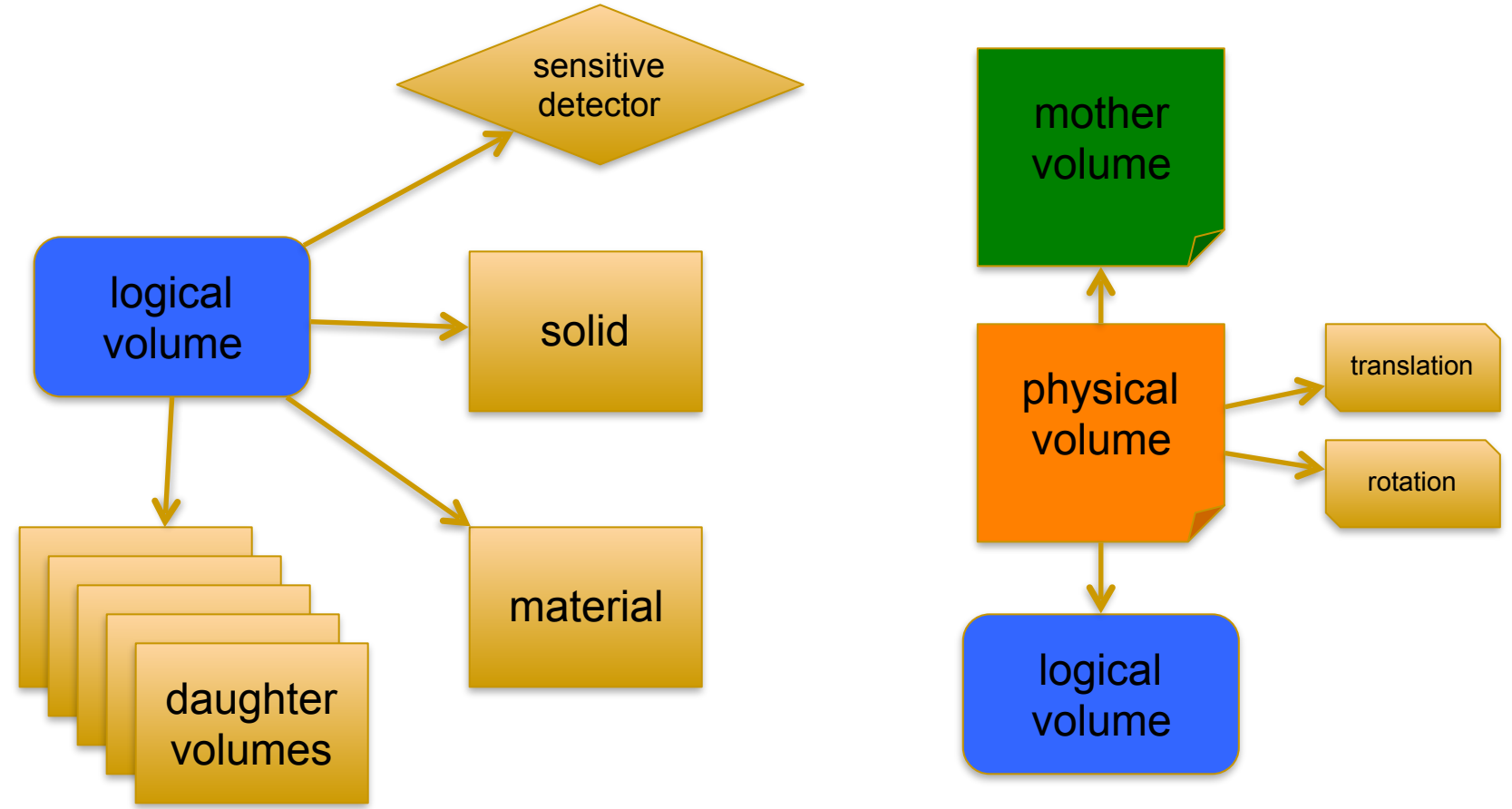
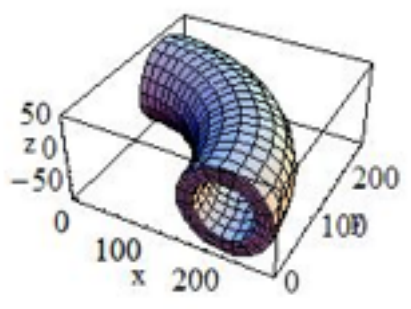
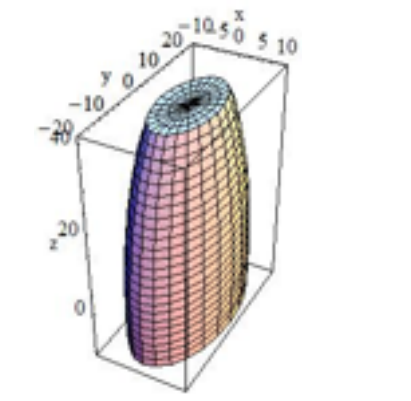
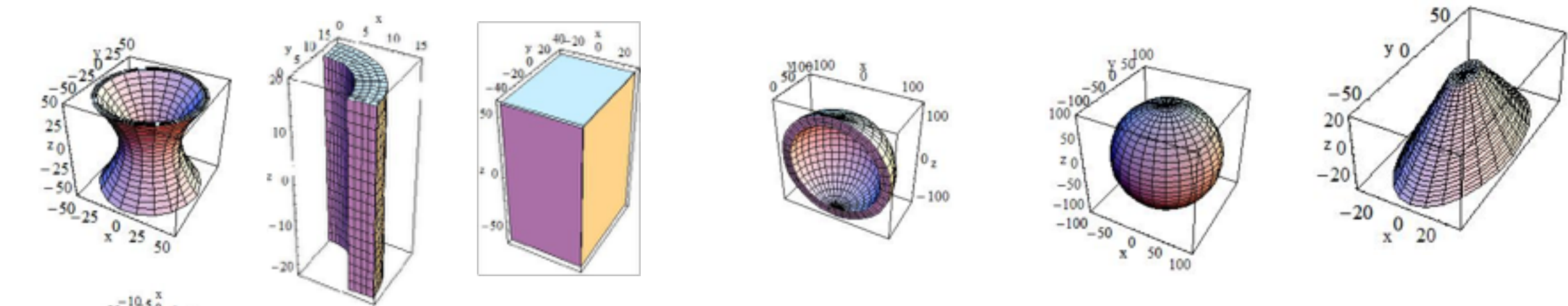



# Advance geometry

- replicas
- divisions
- reflections
- assemblies
- parameterizations



*a daughter  
logical volume to  
be replicated*

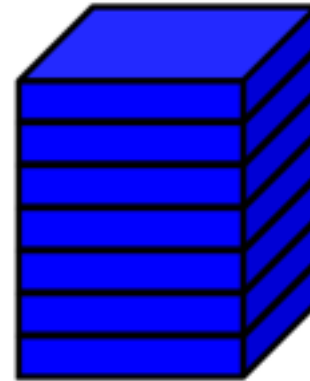

*mother volume*

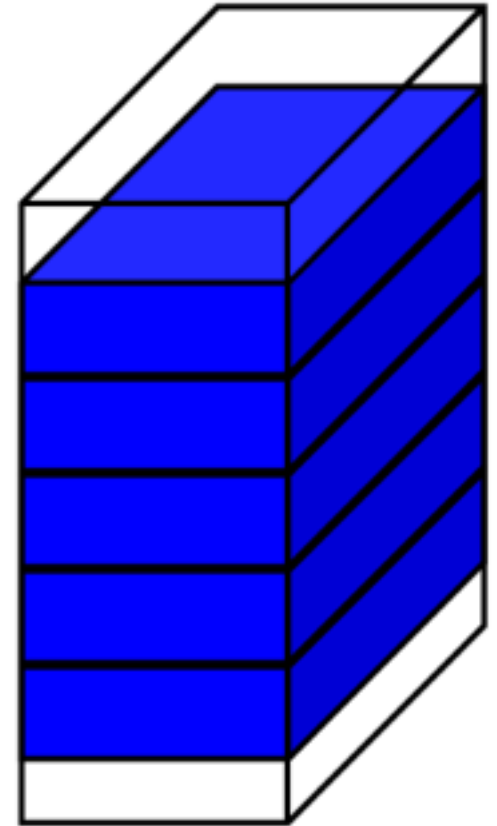

mother  
volume

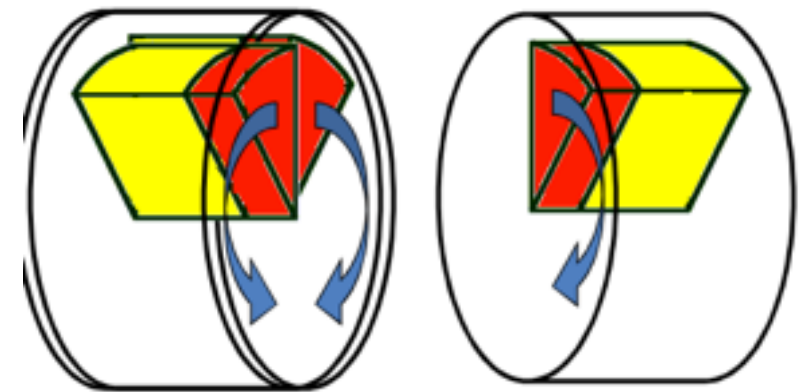
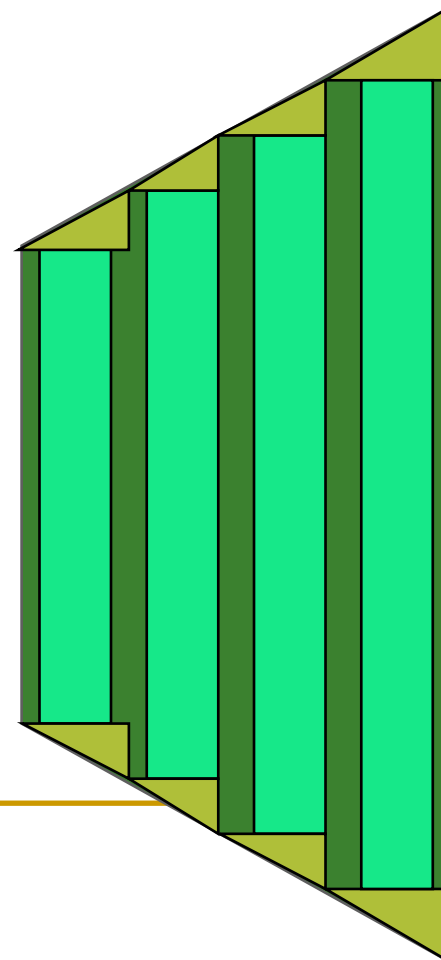
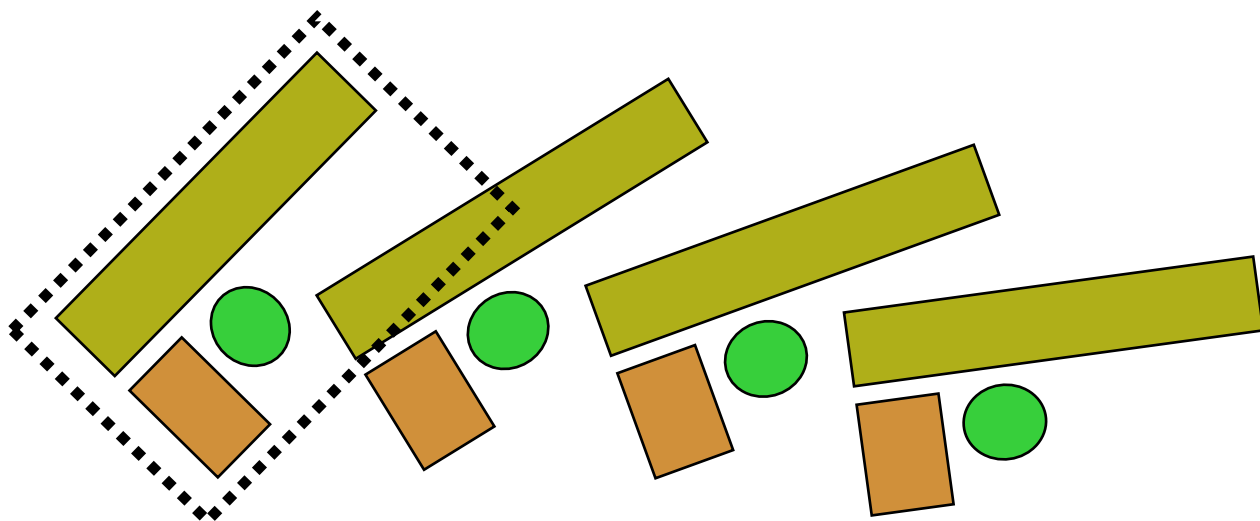

# Materials

- In nature, materials (chemical compounds, mixtures) are made of elements, and elements are made of isotopes
- In Geant4: G4Isotope, G4Element, G4Material
  - users can 'build' their materials, instantiating elements and adding them with the right fractions
- Geant4 contains also National Institute of Standards (**NIST**) database of materials
  - materials can be instantiated directly from it
  - strongly recommended to be used

# Navigation and tracking

- ‘navigator’ role is to provide geometry information to tracking mechanism
  - locates the point in the geometry structure
    - which volume I am in?
  - calculates the distances to the boundaries (along specified direction)
- non-trivial problem of simulation ‘continuous’ physics (space-time) with discrete steps
  - steps cannot be infinitely small
- steps need to be limited by crossing geometrical boundaries, physics or kinetic energy going to 0
- accuracy of tracking on the surfaces defined by geometrical ‘tolerance’

# Magnetic field

- Geant4 can propagate in magnetic fields, electric fields, electromagnetic fields, and gravity fields, uniform or non-uniform
- the equation of motion of the particle in the field is integrated using Runge-Kutta method
  - in particular cases analytical solutions can be used
- curved trajectory broken up in linear cord segments
- parameter 'miss distance' sets how closely the curved path is approximated
- non trivial problem to avoid qualitatively wrong results

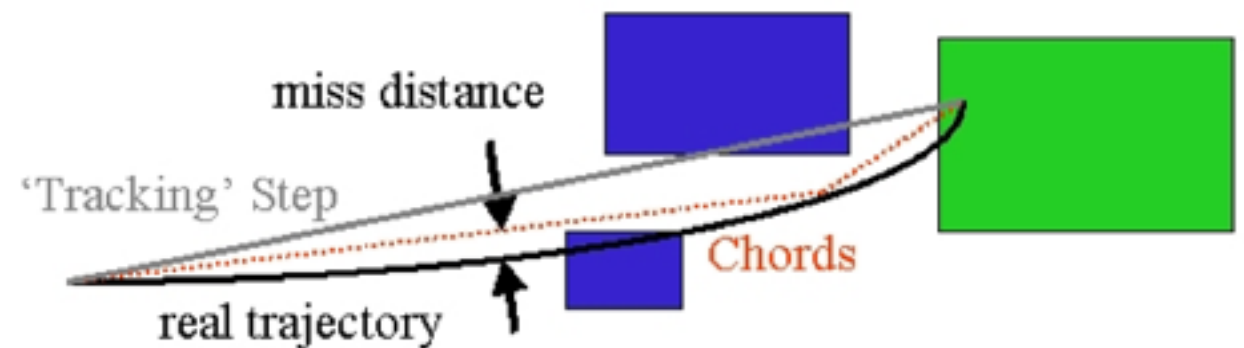

# User actions

- how to control your simulation?
  - ‘user actions’
    - G4UserRunAction
    - G4UserEventAction
    - G4UserStackingAction
    - G4UserTrackingAction
    - G4UserSteppingAction
  - fully customizable (empty by default)
  - allow user to take actions depending on his specific case
    - simulated only relevant particles
    - save specific information, fill histograms
    - speed-up simulation by applying different limits

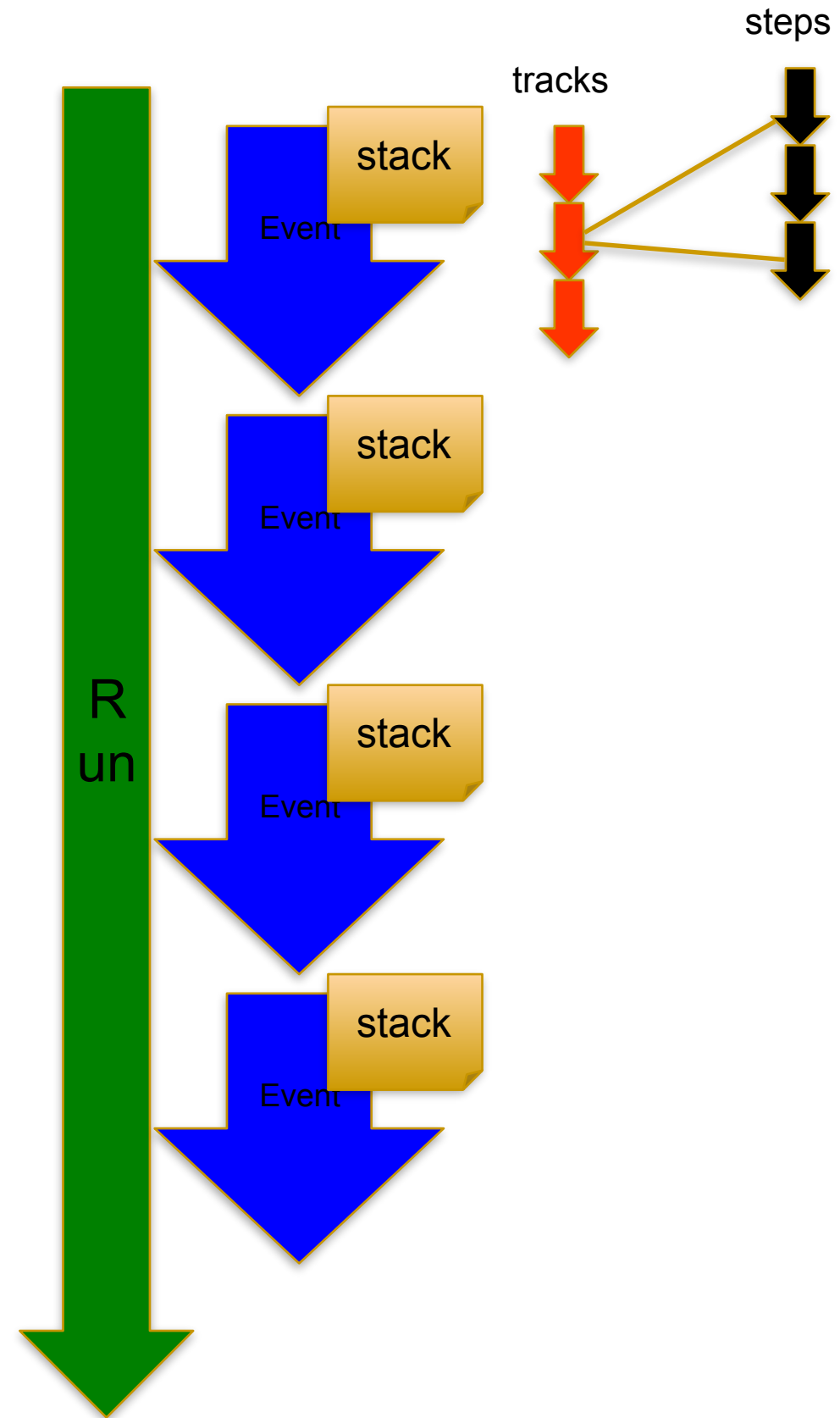

# Users actions – sensitive detectors

- sensitive detectors are user actions attached to specific volumes
  - ProcessHits – invoked when a particle enters the ‘sensitive’ volume
    - allows to create ‘hits’
      - energy deposition, x, y, z coordinates, etc
- they simulate detector response to the particles passing through the sensors

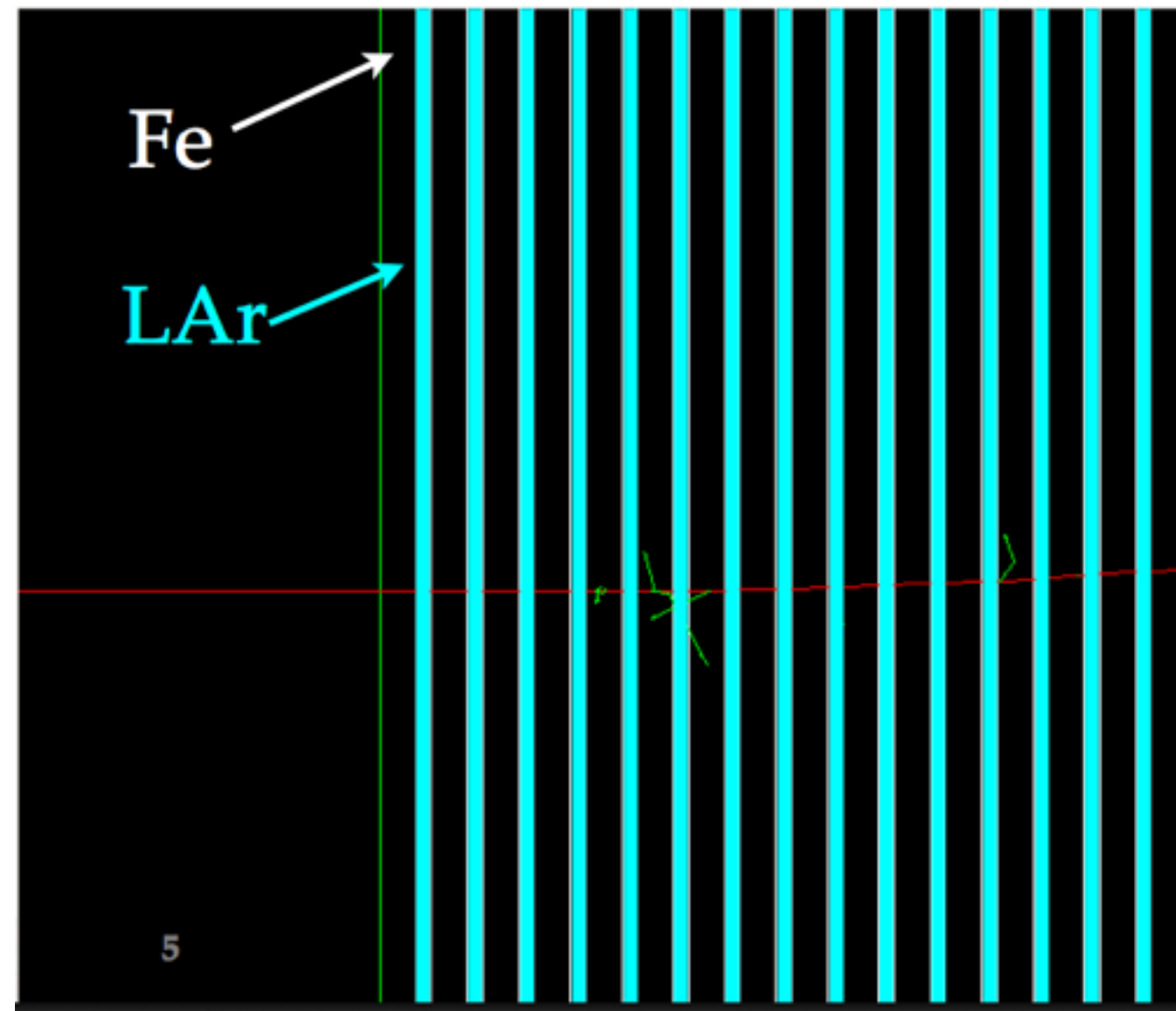

# Physics...

- what happens to a particles in matter?
- we need to implement the physics we know

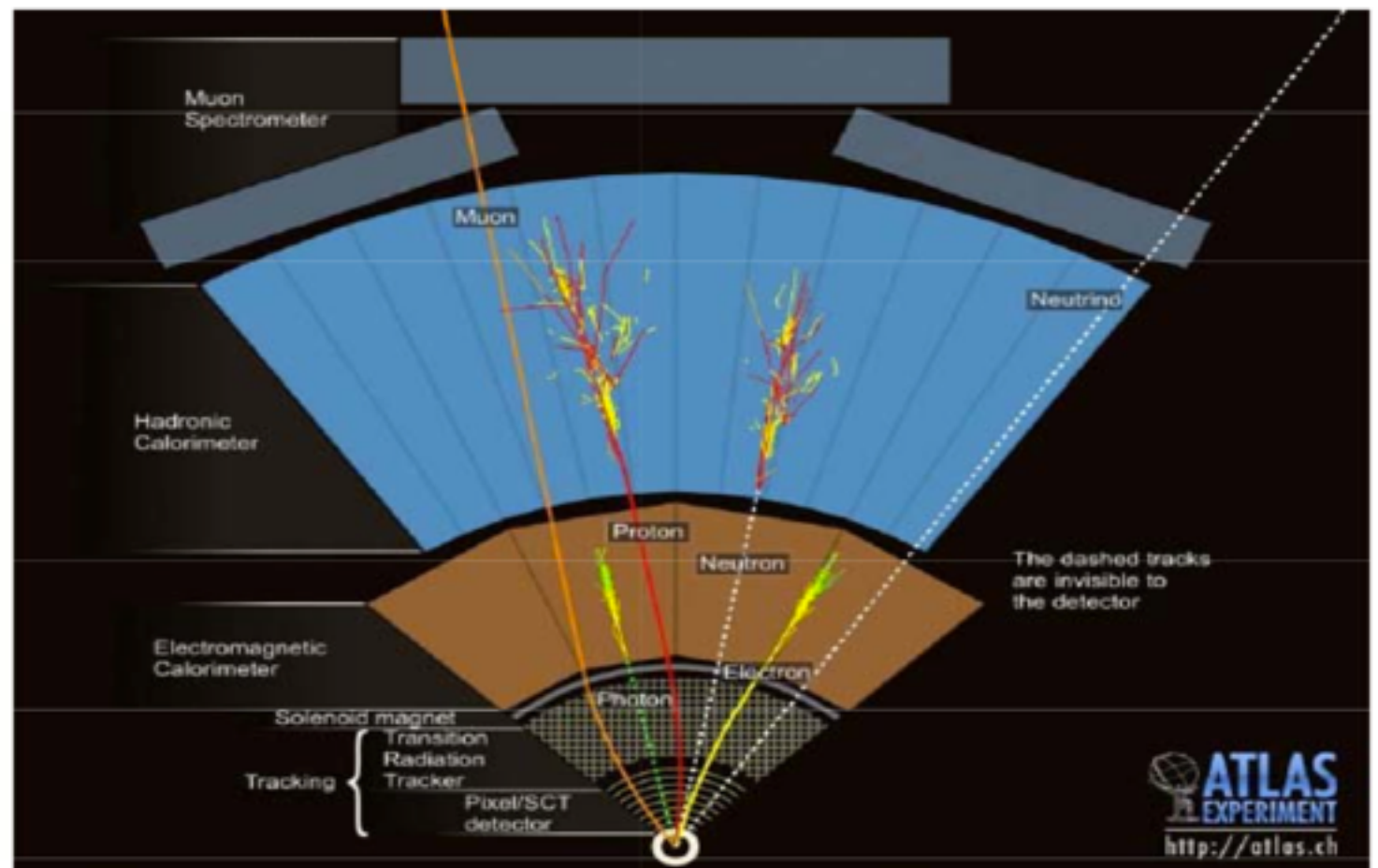



# Electromagnetic (1/2)

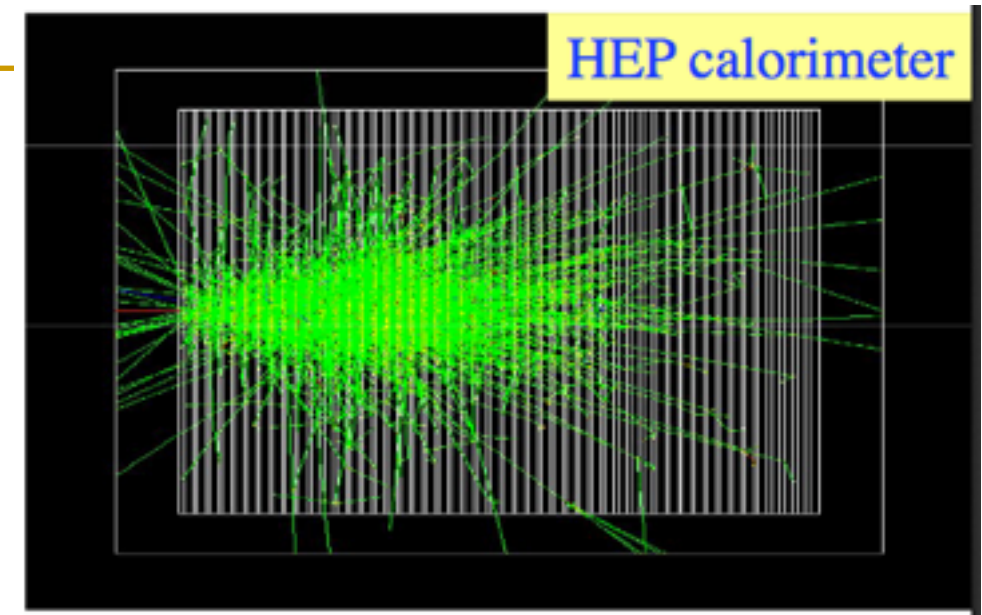

- simulation of electromagnetic interactions of charged particles, gammas and optical photons
  - standard electromagnetic physics
    - optimized for high and medium energy applications
      - energy range from 1keV to 1PeV
  - low energy electromagnetic physics
    - down to eV
      - medical and biological application
        - Geant4-DNA project

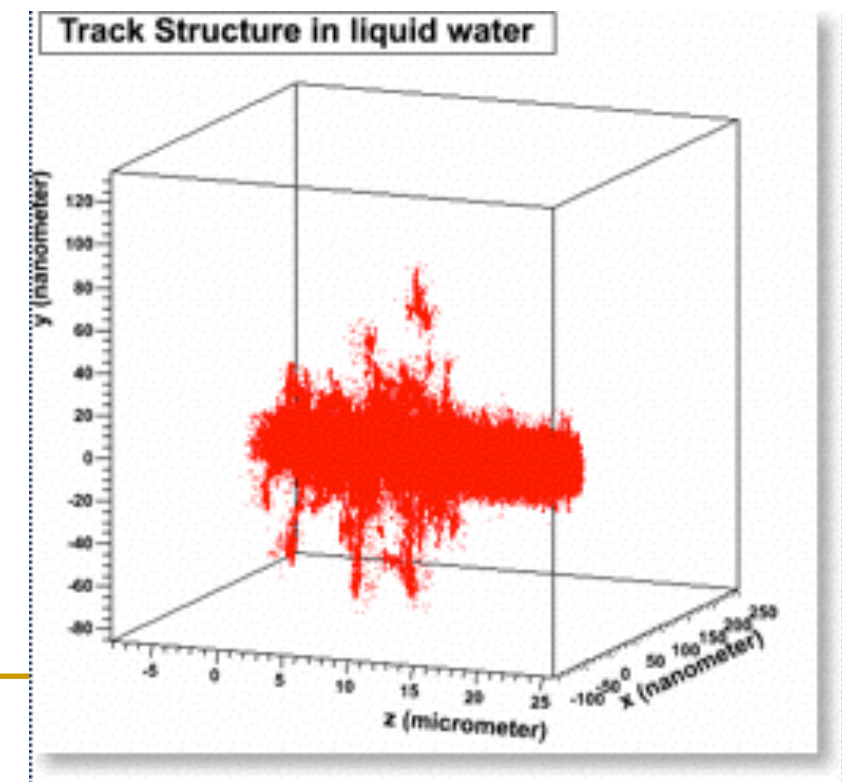



# Electromagnetic (2/2)

- **Gammas:**
  - Gamma-conversion, Compton scattering, Photoelectric effect
- **Leptons(e,  $\mu$ ), charged hadrons, ions**
  - Energy loss (Ionisation, Bremstrahlung), Multiple scattering, Transition radiation, Synchrotron radiation,  $e^+$  annihilation.
- **Photons:**
  - Cerenkov, Rayleigh, Reflection, Refraction, Absorption, Scintillation
- High energy muons
- **A choice of implementations for most processes**
  - “Standard”: performant, where relevant physics above 1 KeV
  - “Low Energy”: Extra accuracy, for application delving below 1 KeV

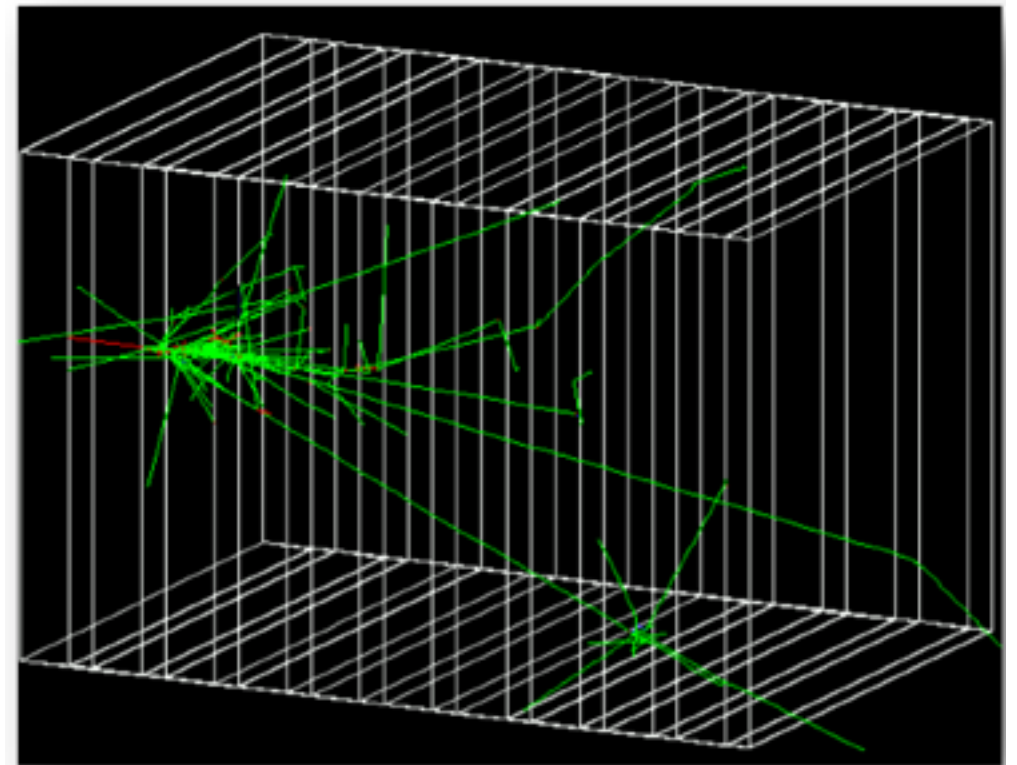

50 MeV  $e^-$  entering  
LAr-Pb calorimeter

# Need for production cuts

- some electromagnetic processes have infrared divergences
  - threshold needed below which no secondaries are generated
    - production threshold for gammas, electrons and positrons
- ‘cuts’ can be defined per region of the geometry
  - detailed simulation of the EM shower in the sensitive part, but no details needed in some ‘dead’ materials (support, etc)
- Geant4 uses ‘cut in **range**’
  - converted to energy for each material
  - assures better coherency of the simulation that a cut in energy would do

# Why cut in range

- traditionally Monte Carlo simulations impose absolute cutoff in energy
  - particle are stopped when this energy is reached
  - remaining energy is dumped at that point
- this can lead to imprecise stopping location and deposition of energy
- there is a particle dependence
  - range of a 10 keV  $\gamma$  in Si is a few cm
  - range of a 10 keV e- in Si is a few microns
- and a material dependence
  - suppose you have a detector made of alternating sheets of Pb and plastic scintillator
  - if the cutoff is OK for Pb it will likely be wrong for the scintillator which does the actual energy measurement

# Cut in range (production threshold) vs. energy cut

Example: 500 MeV p in LAr-Pb Sampling Calorimeter

Geant3 (and others)

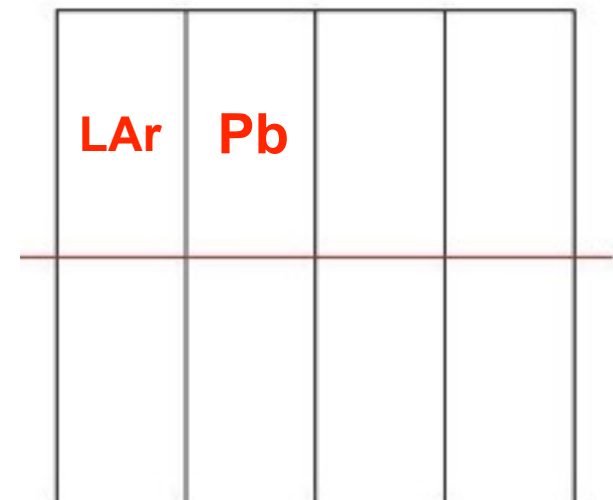

Cut = 2 MeV

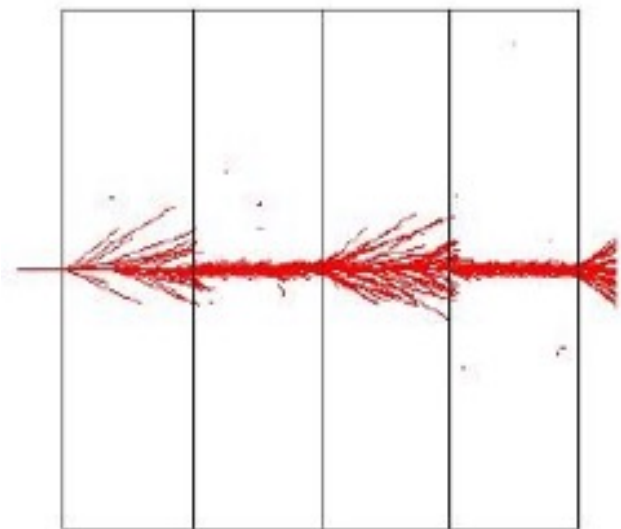

Cut = 450 keV

Geant4

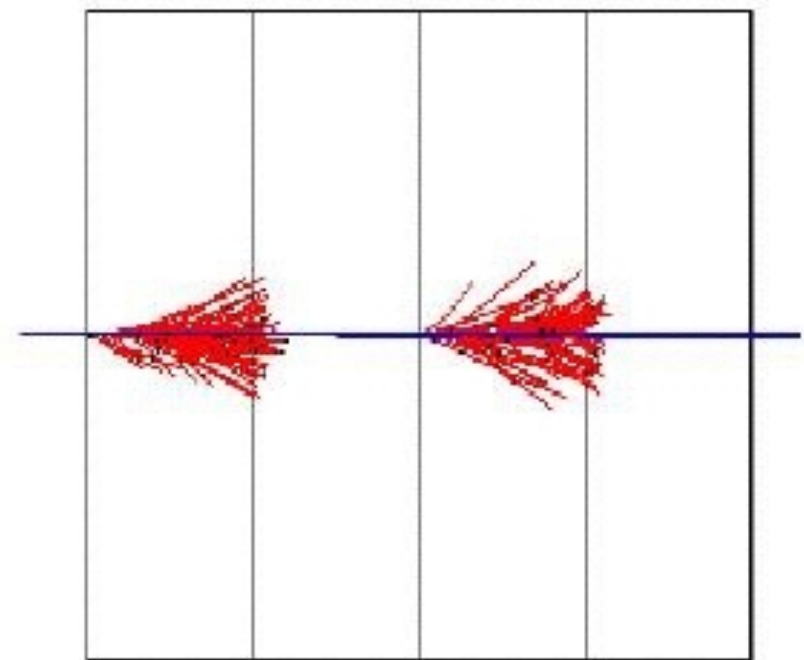

Production range = 1.5 mm

# Partial hadronic model inventory

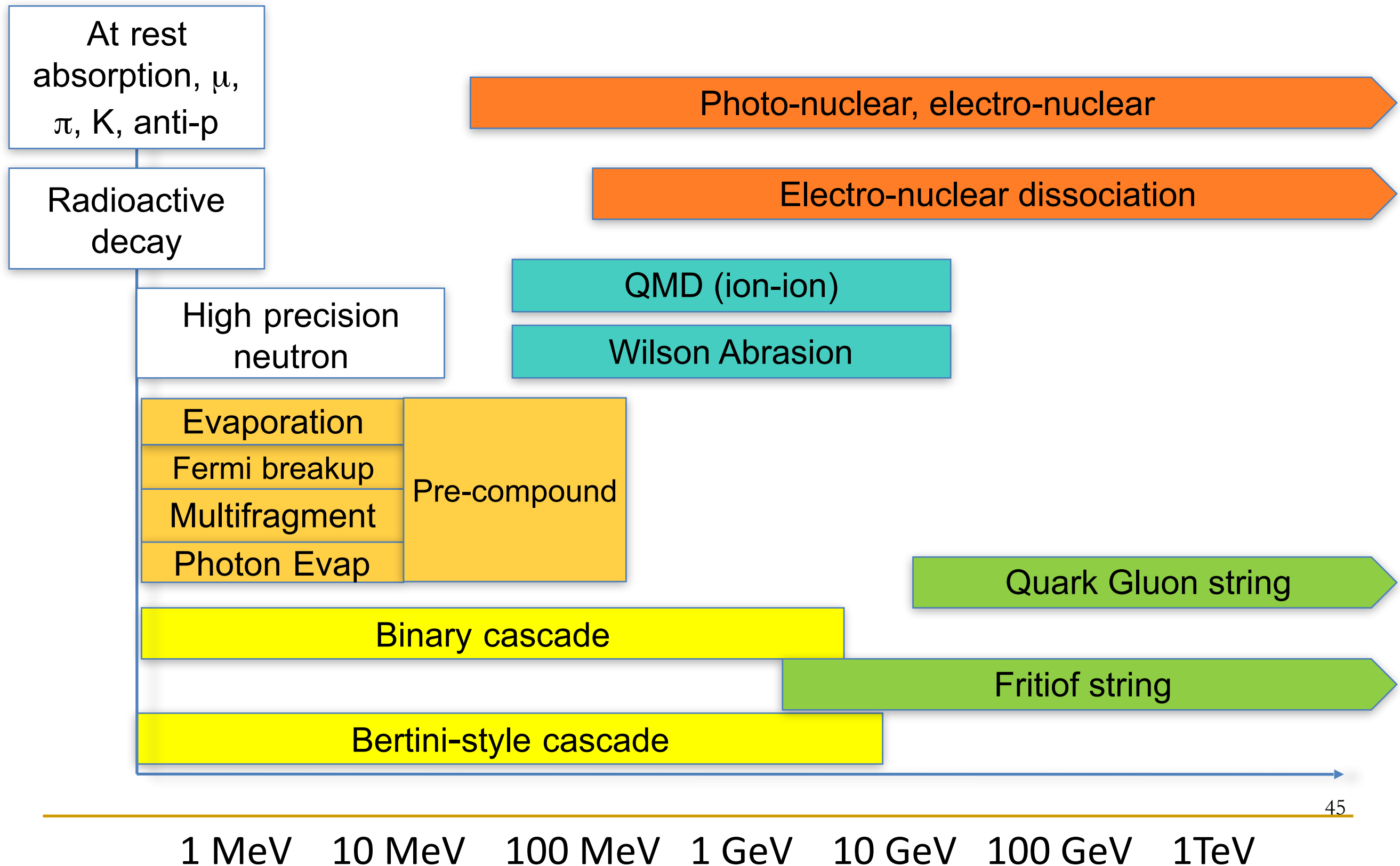

# Geant4 'Physics Lists'

- set of physics models covering all the needed processes for the relevant particles and cross sections for them
- predefined physics lists for specific applications
  - general high energy physics
  - high precision high energy physics (detailed tracking of neutrons)
  - low energy
  - etc

# Visualisation

- visualize
  - geometry
  - tracks
  - hits
- available visualization drivers
  - OpenGL
  - OpenInventor
  - HepRep
  - DAWN
  - VRML
  - RayTracer
  - gMocren
  - ASCIITree

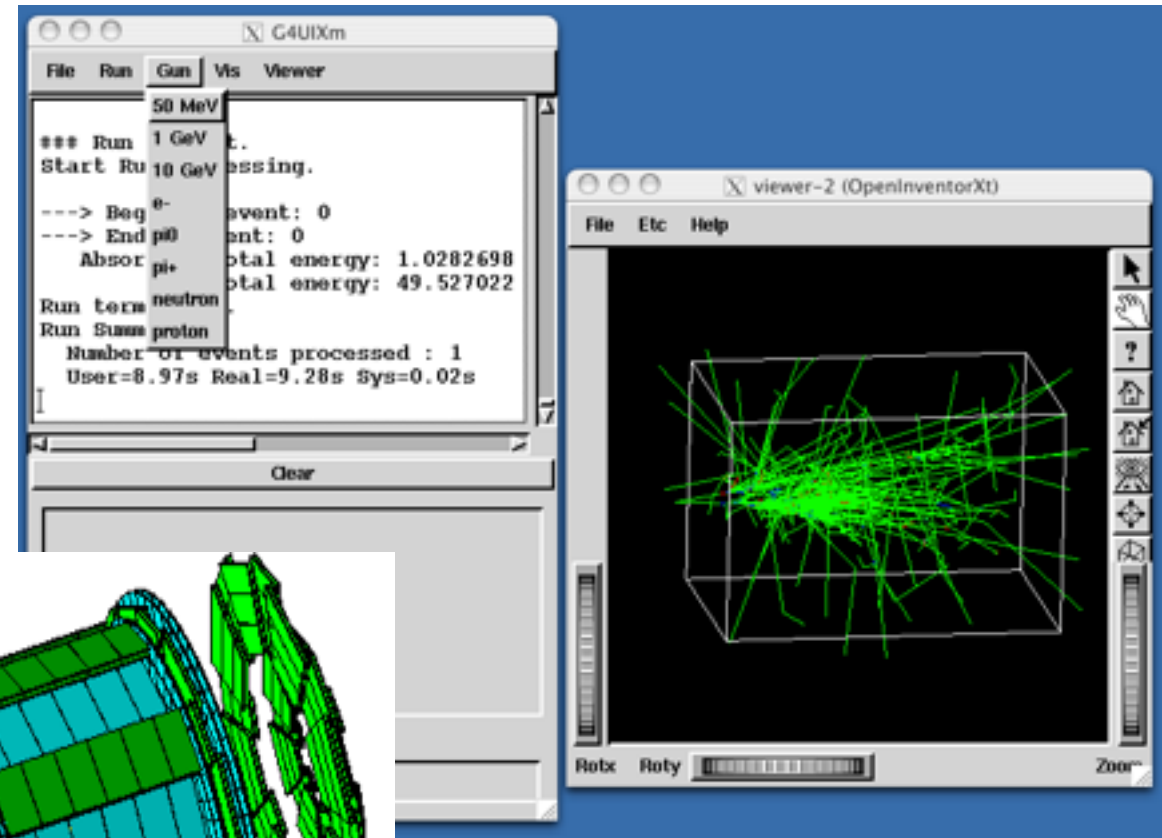
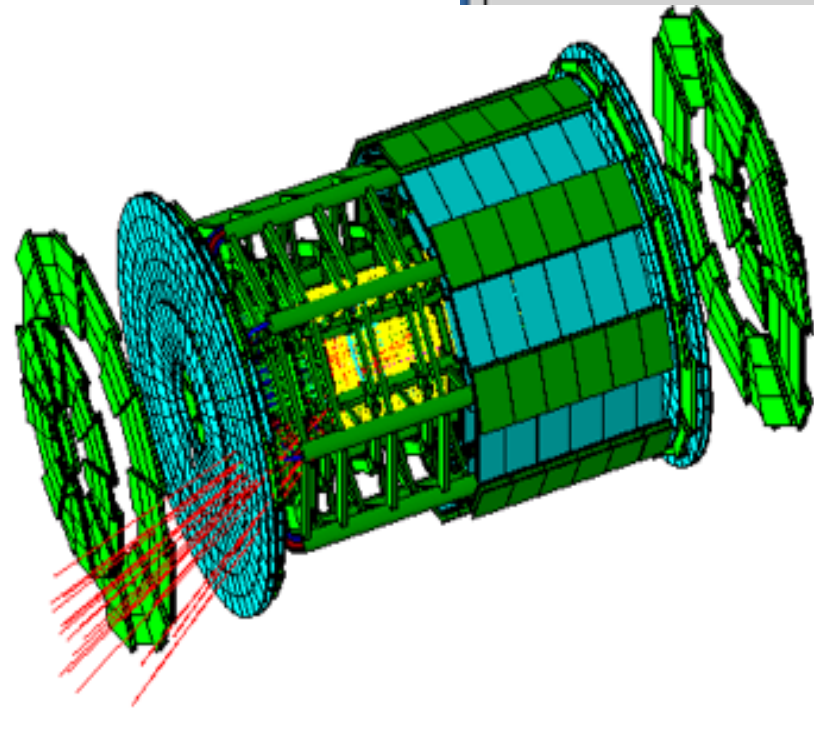



# What you need to make simulation?

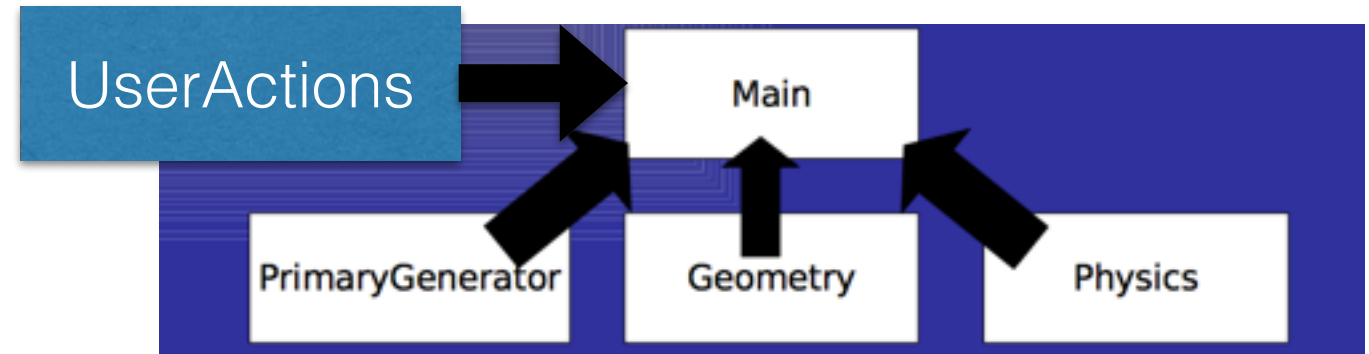
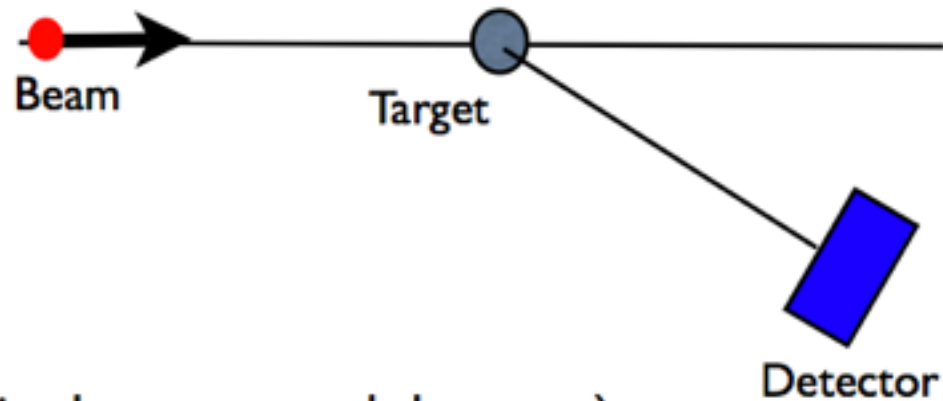

and to get something out of it...



# Conclusion

- Geant4 is a Monte Carlo simulation toolkit used in different domains like High Energy Physics, astrophysics, space research, medical physics, biology, etc
  - it allows you to simulate the passage of the particle through the matter, the process they undergo and the energy deposition they make
- the use of such a simulation is essential to build, understand and use your devices

# Resources for more information

- Geant4 web site
  - <http://cern.ch/geant4/>
- Geant4 Training Page
  - Material form several training courses
    - <http://cern.ch/geant4/support/> “Training” link, or directly
    - <http://geant4.web.cern.ch/geant4/support/training.shtml>
- Geant4 Tutorials, Users Workshops and workshop presentations
  - 2011 Tutorial, CENBG Bordeaux
  - 2009 Users Wrkshp **Catania** (October 09)
    - <http://www.lns.infn.it/geant4/geant4ws2009/>
      - Look for [Timetable](#)
  - 2008 [Kobe](#), 2007 [UK](#), 2006 [Lisbon](#)
  - 2005 **Bordeaux** – several sessions focus on Medical applications
    - <http://geant4.in2p3.fr/2005/>
  - Workshops and Users Workshops links at
    - <http://geant4.web.cern.ch/geant4/collaboration/workshops.shtml>
- Geant4 [Physics Validation](#)
  - | [EM https://twiki.cern.ch/twiki/bin/view/Geant4/EMValidation](https://twiki.cern.ch/twiki/bin/view/Geant4/EMValidation)
  - | [Hadronic http://geant4.fnal.gov/hadronic\\_validation/validation\\_plots.htm](http://geant4.fnal.gov/hadronic_validation/validation_plots.htm)
- [Working Group web sites](#)
  - | [Electromagnetic: Standard & Low-Energy, Hadronic](#), at
    - | [http://cern.ch/geant4/organisation/working\\_groups.html](http://cern.ch/geant4/organisation/working_groups.html)
- Many papers on [Geant4](#) and its validation
- | First ‘reference’ paper
  - | [“Geant4: a simulation toolkit”, Nucl. Instr. and Methods A 506 \(2003\), 250-303.](#)

# Geant4 is an International Collaboration

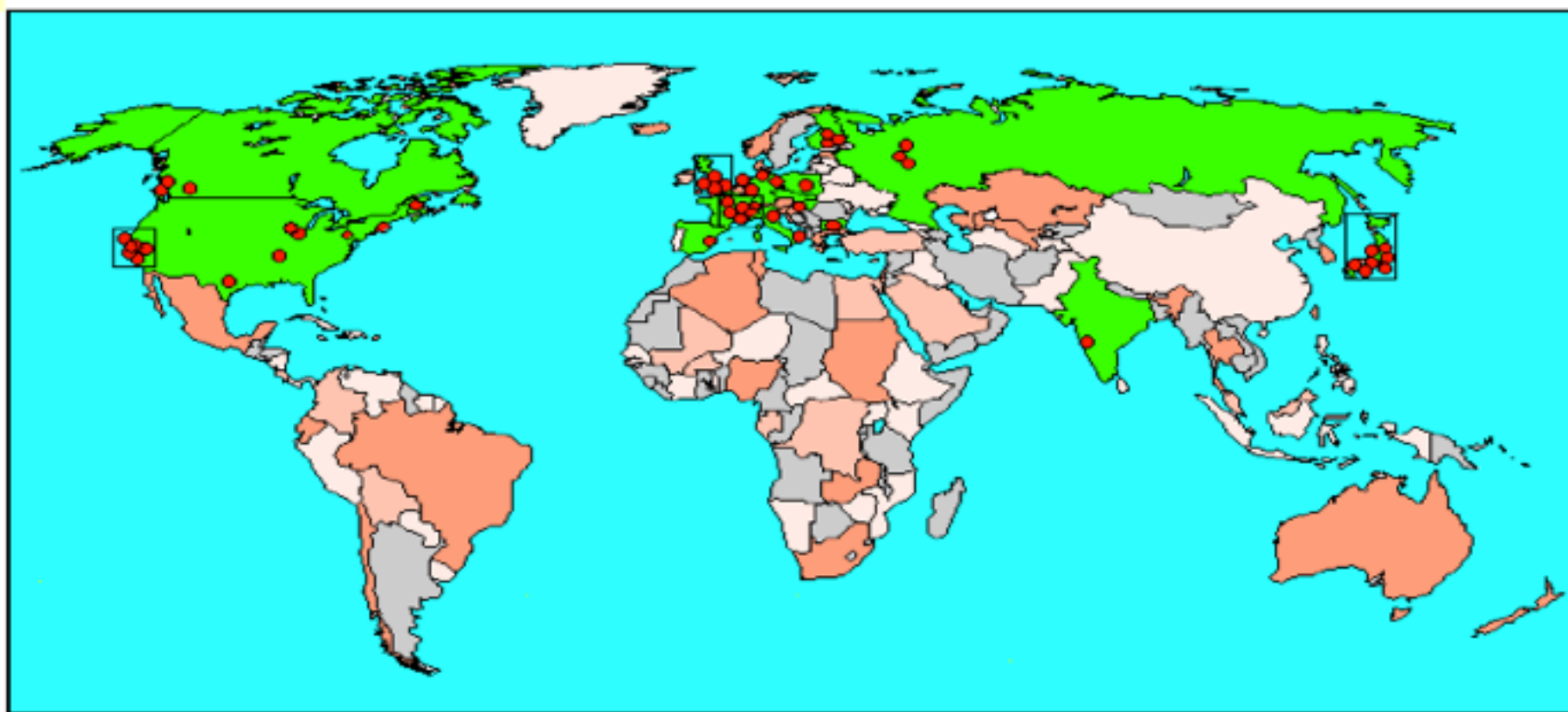
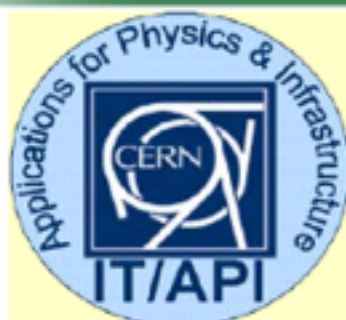

UNIVERSITAT DE BARCELONA

Collaborators also from non-member institutions, including  
Budker Inst. of Physics  
IHEP Protvino  
MEPHI Moscow  
Pittsburg University

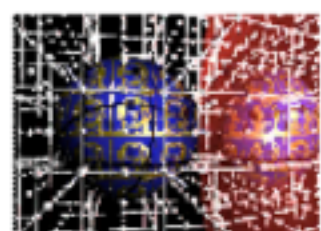

J.W.Goethe  
Universität