

704 MHz klystrons for ESS

Chiara Marrelli

www.europeanspallationsource.se

16-06-21

- The ESS project
- High power amplifiers for ESS
 - RFQ and DTL amplifiers
 - Spoke Amplifiers
- 704 MHz klystrons
- Medium Beta klystron Prototypes specifications and first results:
 - Toshiba
 - Thales
 - CPI

The ESS project

- ESS is a neutron spallation source for neutron scattering measurements.
- The neutrons are produced by a 2 GeV proton beam impacting on a tungsten target.
- The proton linac will be the most powerful ever built and it will require over 150 RF sources.

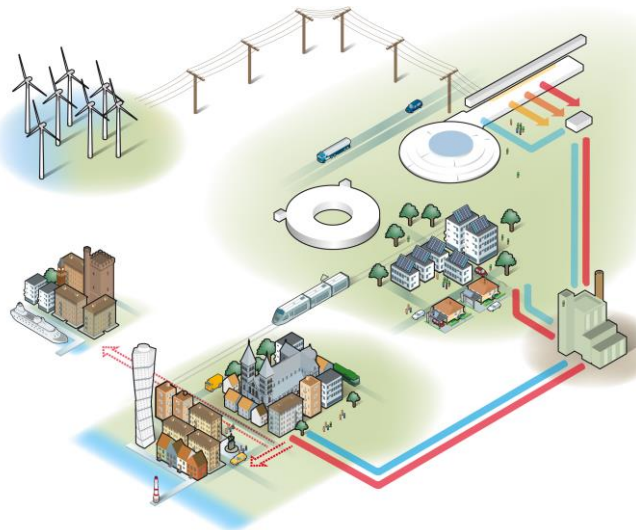
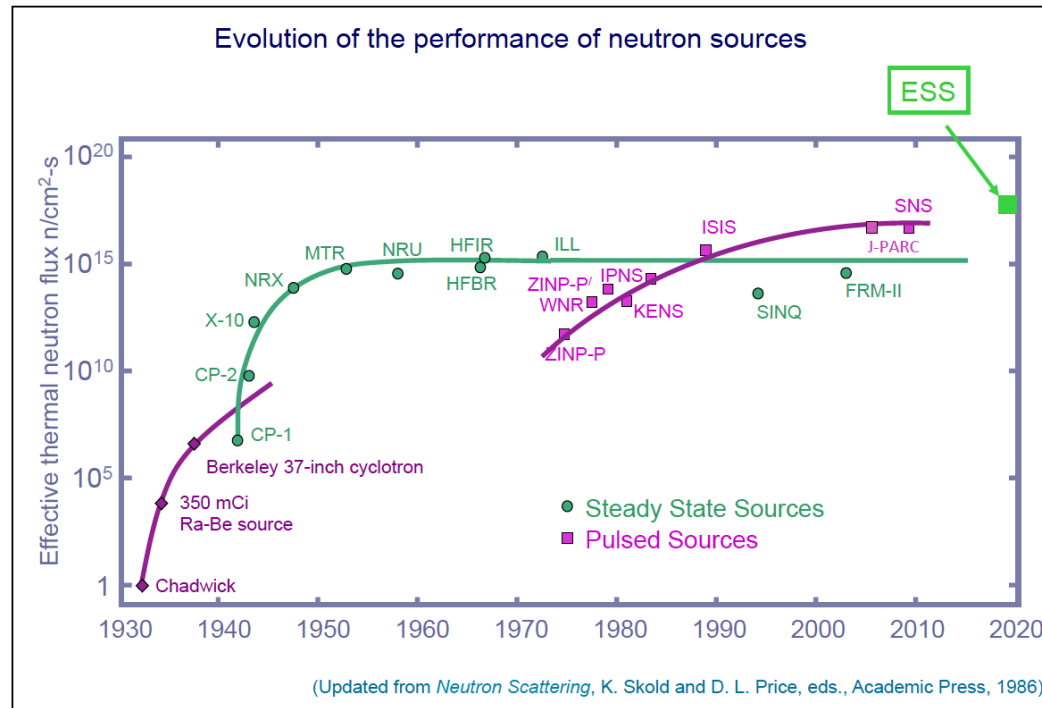

ESS will be a “green” facility: this means that it must guarantee at the same time:

- Machine reliability
- Energy efficiency



The ESS project

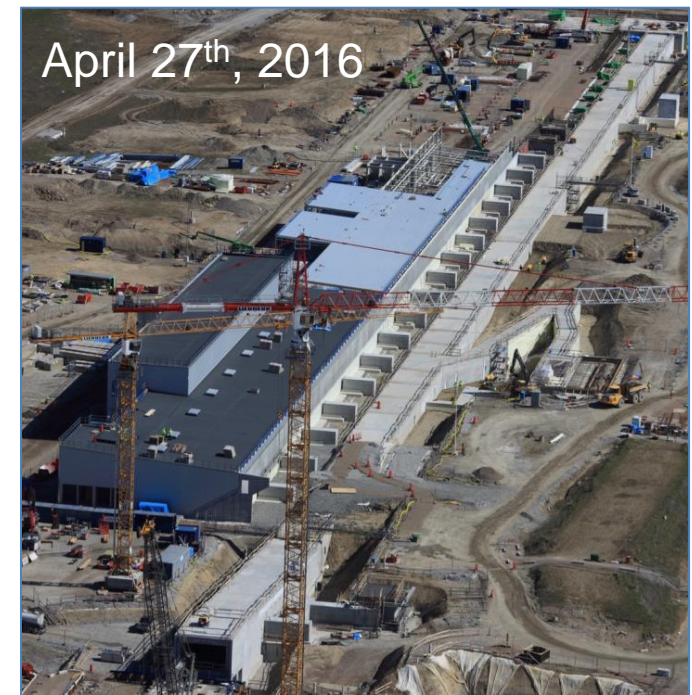

The ESS accelerator

ESS **accelerator** parameters:

Average beam power: 5 MW

Pulse length: 2.86 ms

Peak beam power: 125 MW

Pulse repetition rate: 14 Hz

Proton energy: 2 GeV

Peak beam current: 62.5 mA

High availability: >95%

Flexible design for a future power upgrade

- First beam at 572 MeV in June 2019
- 5 MW capacity by 2023

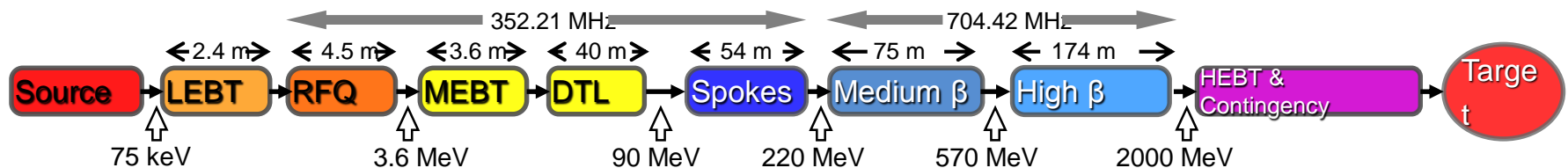

The ESS accelerator

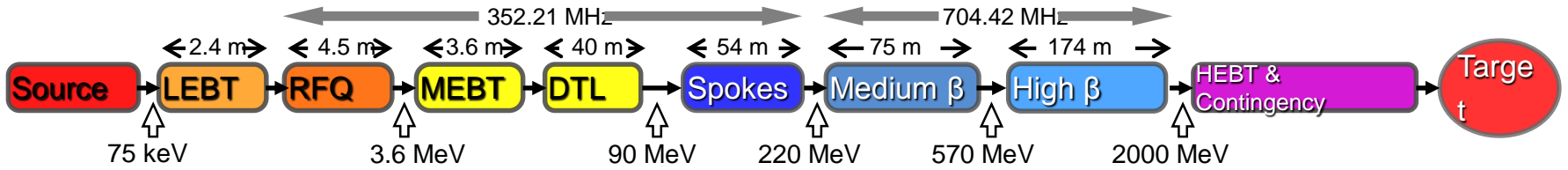

Normal-conducting Linac:

- 1 RFQ: 1.6 MW at 352 MHz required in input + 30% (overhead + losses);
- 5 DTL tanks (2 couplers/DTL): 2.2 MW at 352 MHz required in input + 30% (overhead + losses);
- 3 buncher cavities (Solid state amplifiers): 352 MHz, 30 kW

	Energy (MeV)	Frequency (MHz)	No. of Cavities	β_g	Temp ($^{\circ}$ K)	RF power (kW)
Source	0.075	-	0	-	\sim 300	-
LEBT	0.075	-	0	-	\sim 300	-
RFQ	3.6	352.21	1	-	\sim 300	1600**
MEBT	3.6	352.21	3	-	\sim 300	20**
DTL	90	352.21	5	-	\sim 300	2200**
Spoke	220	352.21	26 (2/CM)	0.5 β_{opt}	\sim 2	330**
Medium β	570	704.42	36 (4/CM)	0.67	\sim 2	870**
High β	2000	704.42	84 (4/CM)	0.86	\sim 2	1100**
HEBT	2000	-	0	-	\sim 300	-

Superconducting Linac (97%):

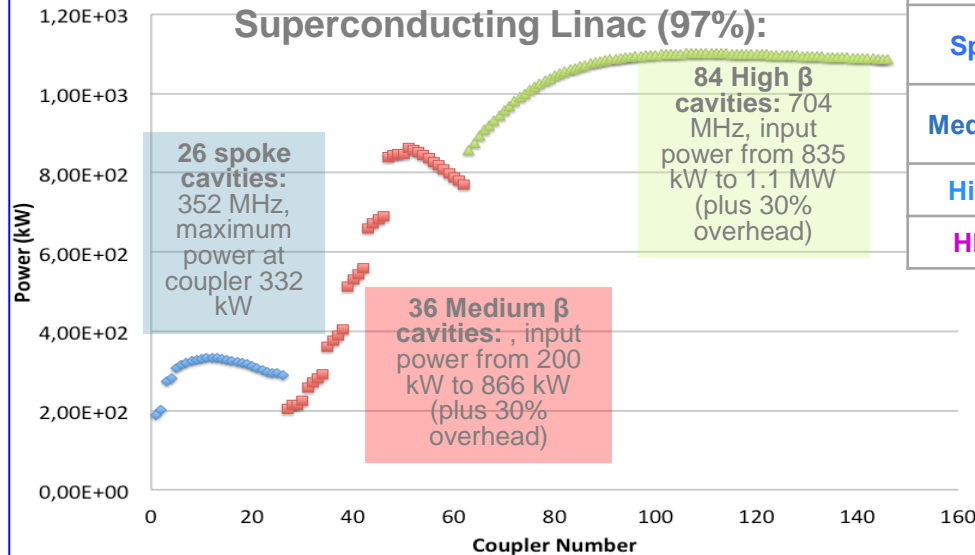

Total High Power RF: 133 MW peak (4% duty) plus overhead

** Plus overhead for control

High Power Amplifiers

Section	Power /kW	Baseline technology	Status
Normal conducting RFQ and DTL	2900	Klystron	In kind (ESS Bilbao)
Normal conducting bunchers	30	Solid State	In kind (ESS Bilbao)
Spoke linac	400	Tetrode	In kind (Elettra)
Medium beta linac	1500	Klystron	Prototyping
High beta linac	1500/1200 Klystron/IO T	MB-IOT (decision end 2017)	Prototyping

Schedule RF systems

- The RF systems shall be ready to power beam for the linac up to and including medium beta by June 2019
- RF for the High Beta part shall be ready to power beam by 2022
- Installation shall start autumn 2017

RFQ and DTL

- 1 RFQ (1.6 MW input power at 352.21 MHz)
- 5 DTL tanks (2.2 MW input power at 352.21 MHz for each DTL, two couplers per DTL)

25% overhead + 5% losses in RF distribution

- 2.1 MW saturated power from the RFQ klystron
- 2.9 MW saturated power from the DTL klystrons
- One modulator every two klystrons

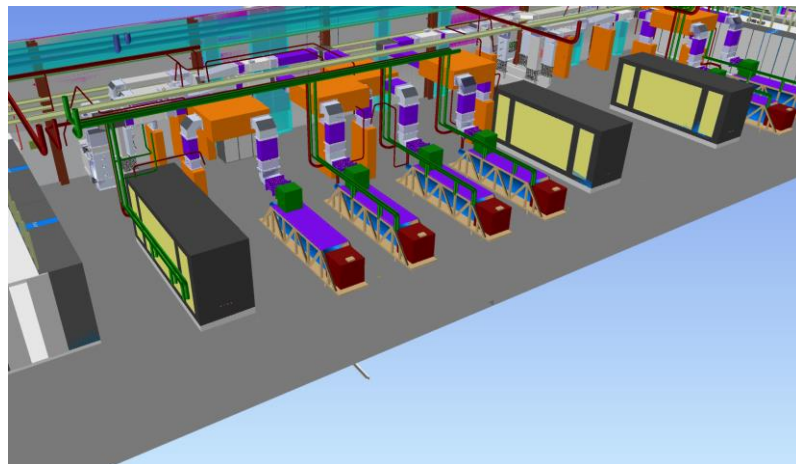

Klystron specs:

Nominal output power	3 MW
Frequency	352.21 MHz
BW	≥ +/- 1 MHz
Pulse width	3.5 ms
Repetition rate	14 Hz
Perveance	$1.3 \cdot 10^{-6}$
Efficiency	>52%
VSWR	Up to 1.2
Power Gain	≥ 40 dB
Group Delay	≤ 250 ns
Harmonic Spectral content	≤ -30 dBc
Spurious Spectral content	≤ -60 dBc

RFQ and DTL

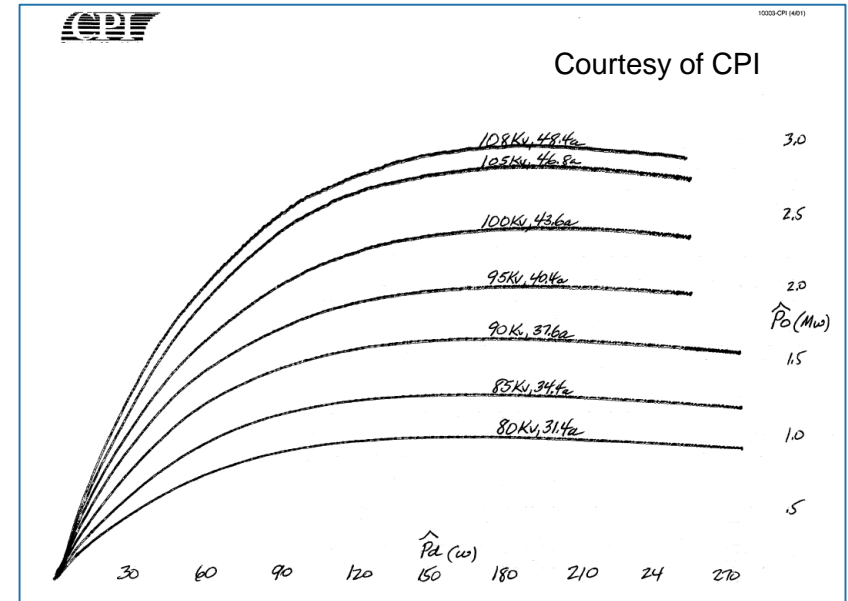
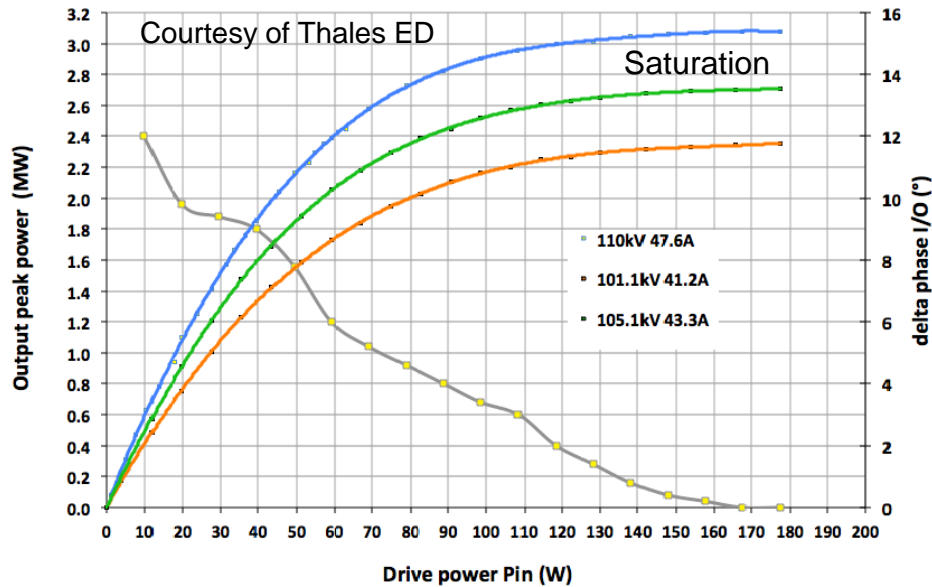

In-kind from ESS Bilbao

Two klystrons currently available:

Dimensions: 5.3 m x 1.5 m x 1 m



Thales
TH2179



CPI VKP-
8352A

Spoke linac amplifiers

- 26 double spoke cavities
- Power requirement: up to 400 kW peak at 352.21 MHz

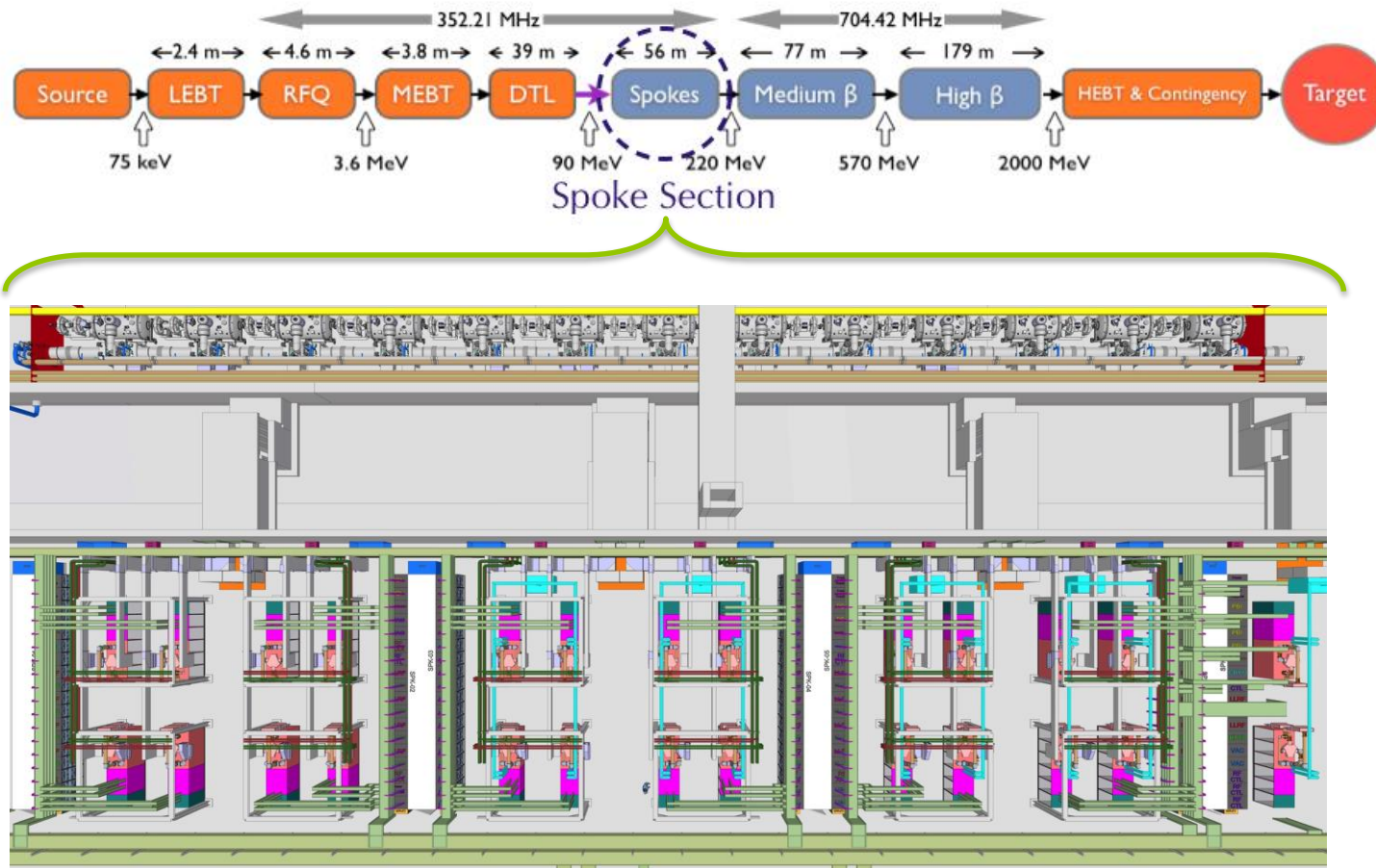

Spoke linac amplifiers

At present, the **Tetrode-based** RF power amplifier solution is envisaged to be used for the ESS Linac spoke section. The maximum required 400 kW peak power is achieved by the combination of outputs of two tubes working in parallel. The tubes are driven by two 10 kWpk solid-state based amplifiers.

In-kind from Elettra Sincrotrone Trieste

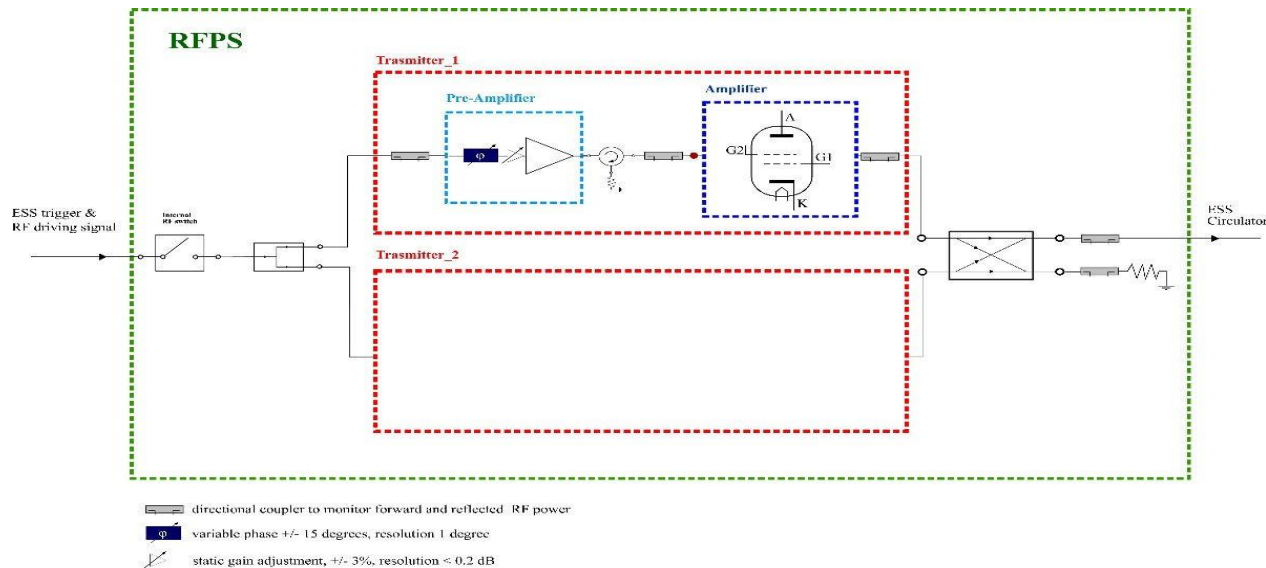

Tetrode TH595

THALES

The **Solid-state** amplifier technology is constantly gaining popularity for the accelerator RF power sources:

- Continuous R&D from the amplifier and solid-state components industry.
- New developments of RF power modules, combination scheme etc. are being done by many accelerator laboratories.

Medium (and High) Beta amplifiers

36 Medium beta elliptical cavities: 704.42 MHz, input power from 200 kW to 866 kW (plus 30% for losses compensation and overhead) -> saturated power from klystrons up to 1.15 MW

Klystron specifications

Nominal output power	1.5 MW
----------------------	--------

Frequency	704.42 MHz
-----------	------------

BW	$\geq \pm 1$ MHz
----	------------------

Pulse width	3.5 ms
-------------	--------

Repetition rate	14 Hz
-----------------	-------

Efficiency	>60%
------------	------

VSWR	Up to 1.2
------	-----------

Power Gain	≥ 40 dB
------------	--------------

Group Delay	≤ 250 ns
-------------	---------------

Harmonic Spectral content	≤ -30 dBc
---------------------------	----------------

Spurious Spectral content	≤ -60 dBc
---------------------------	----------------

84 High beta elliptical cavities: 704.42 MHz, input power from 835 kW to 1.1 MW (plus overhead); 1.2 MW **MBIOTs** (or klystrons as backup)

MBIOT specifications

Peak output power	> 1.2 MW
-------------------	----------

Frequency	704.42 MHz
-----------	------------

BW	$\geq \pm 1$ MHz
----	------------------

Pulse width	3.5 ms
-------------	--------

Duty factor	Up to 5%
-------------	----------

Efficiency	>65%
------------	------

Overall efficiency (including idle current)	>65%
---	------

Gain	> 20 dB
------	---------

Beam Voltage	< 50 kV
--------------	---------

Beam current	< 45 A rms
--------------	------------

Tube life	≥ 50 khrs
-----------	----------------

 See talk from M. Jensen

Medium Beta klystrons

4.5 Cells of 8 klystrons for Medium Beta
10.5 Cells of 8 klystrons (MBIOTs) for High Beta

One 660 kVA modulator will power 4 klystrons

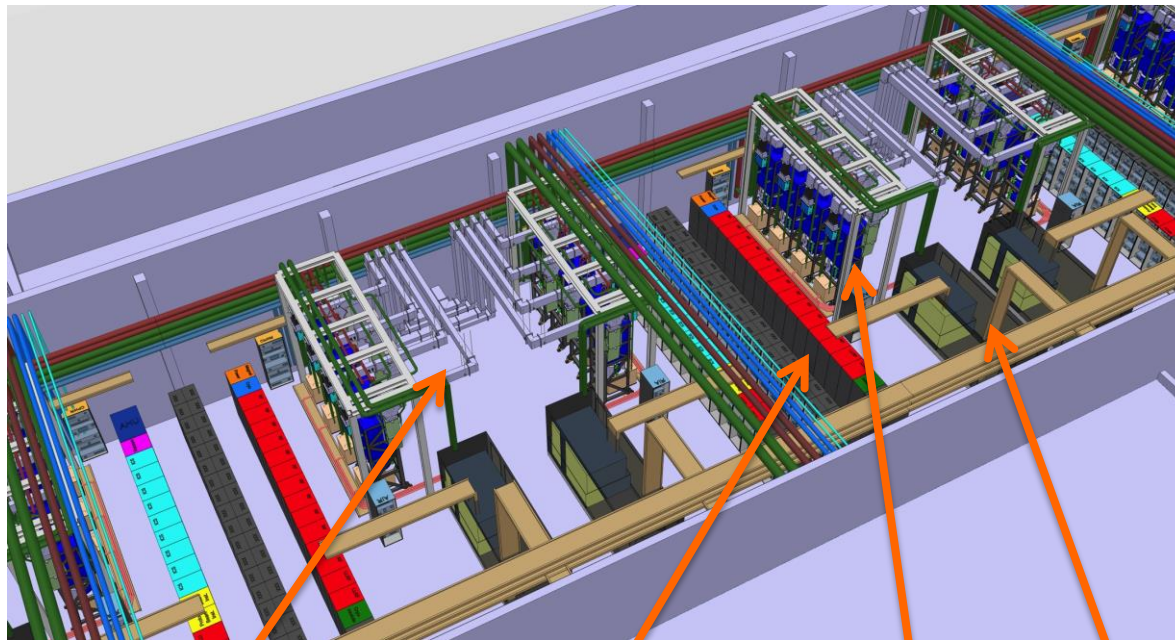

WR1150
Distribution

Racks and
Controls

Klystrons

Modulators

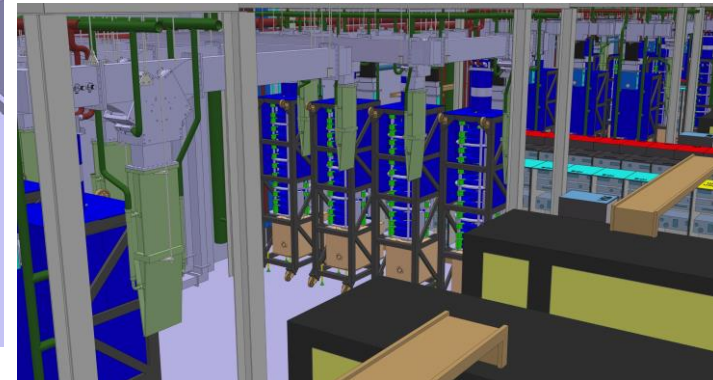
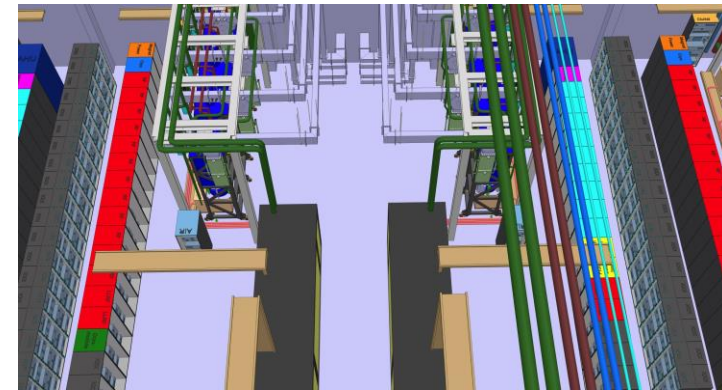

The klystrons will have vertical orientation in order to fit in the gallery

Medium Beta klystrons

Three prototypes procured:

- Thales (contract placed in January 2015)
- Toshiba (contract placed in February 2015)
- CPI (contract placed in April 2015)

Contract duration: 15 months

- Toshiba prototype already delivered
- Thales prototype to be delivered in August 2016
- CPI prototype to be delivered in August 2016

Procurement of the 36 series klystron to start in Fall 2016

Klystron efficient operation at ESS

$$\eta = \frac{P_{out}}{P_0} = \frac{P_{out}}{I_0 V_0}$$

- Klystrons reach maximum efficiency at saturation (not more than 65% for our 704 MHz klystrons, and 55-57% for the 352 MHz klystrons).
- Due to need of overhead for regulation purposes we can't operate them in saturation but we need to stay in the linear region; this will reduce the efficiency
- The power levels required from the klystrons in the medium beta section vary from 272 kW to 1.14 MW; if we operate all the klystrons at the same design beam power (≈ 112 kV, 22 A) efficiency will be as low as 11% for the first amplifiers of the section!
- **It is then important that we are able to operate the klystrons at reduced beam voltages**

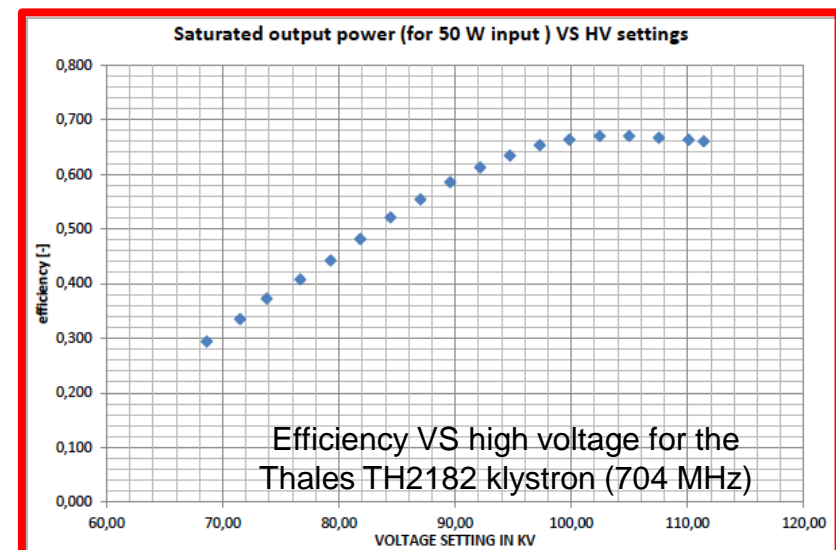
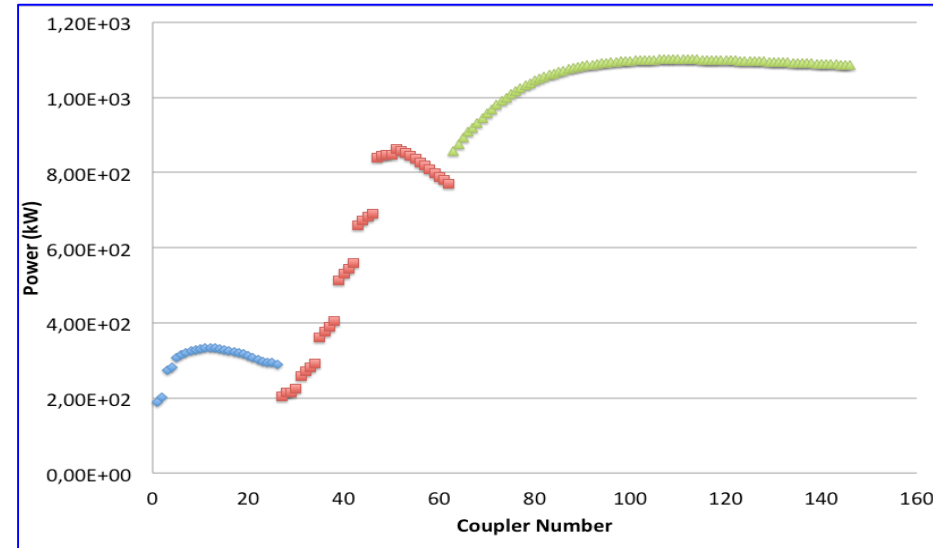

But this is not enough! Efficiency varies with the beam voltage

Klystron operation at reduced beam power

Why does efficiency go down?

- When reducing the beam voltage and current the space charge forces between the electrons vary and reduced plasma wavelength changes
- In other words, the klystron electrical length is modified -> the cavity position, strictly related to the r.p.w., is not optimal anymore
- Furthermore, the impedance of the beam increases -> the external Q of the output gap is also not optimal anymore



Possible solutions:

- The plasma wavelength can be slightly changed by acting on beam radius -> changing magnetic focusing field
- The external Q of the output cavity can be adjusted by varying the matching of the output cavity (output VSWR)
- All these solutions have been discussed with the klystron suppliers

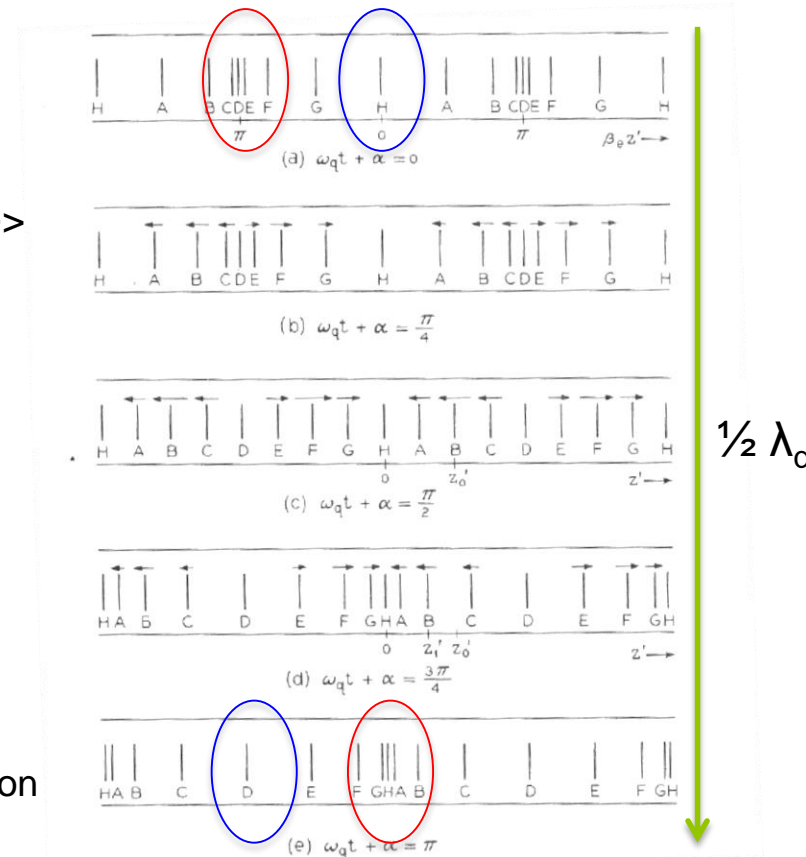

Oscillations due to space charge forces in a reference frame moving at the DC velocity of the electrons. (1-D model)

Medium Beta klystrons

- “Standard” klystron design with 6 cavities including three gain cavities and one second harmonic
- Target efficiency 65% (saturated)
- FUG filament power supply (HF transformer in the oil tank + low voltage unit) + current limiting resistors
- Collector designed to operate with a cooling water temperature up to 60 °C.
- Two arc detection systems can be used (CERN/Microstep and AFT)

The external Q of the output cavity can be changed to increase the efficiency of the klystron when operating at low beam voltages; this is done by introducing a mismatch at the klystron output. The use of the mismatch allows to keep nominal efficiency also at low power levels.

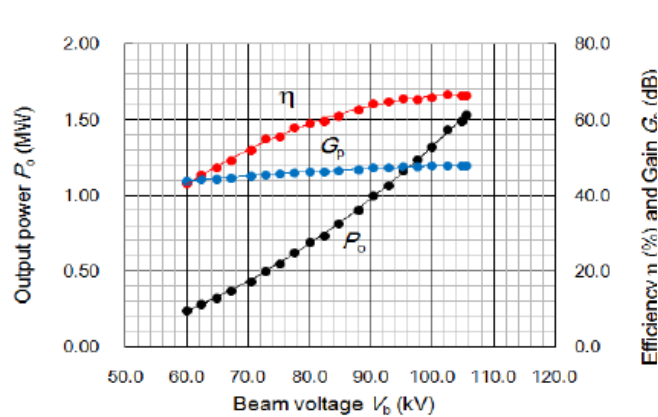

Measured data (no mismatch used at the output)
Courtesy of Toshiba

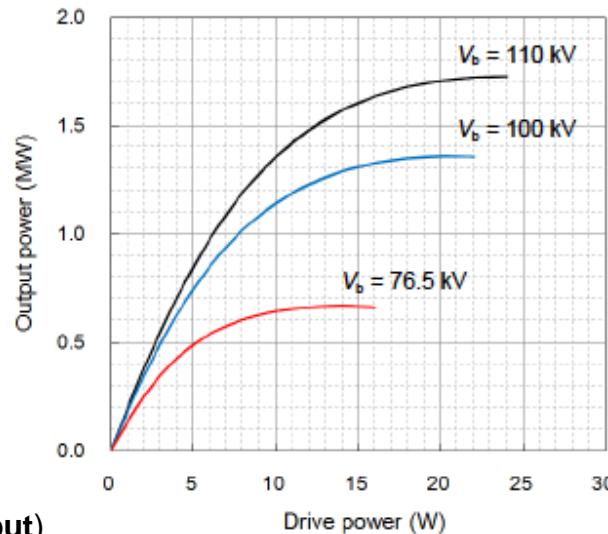

Simulated data: the output match is modified to keep high efficiency at reduced beam voltage (courtesy of Toshiba)

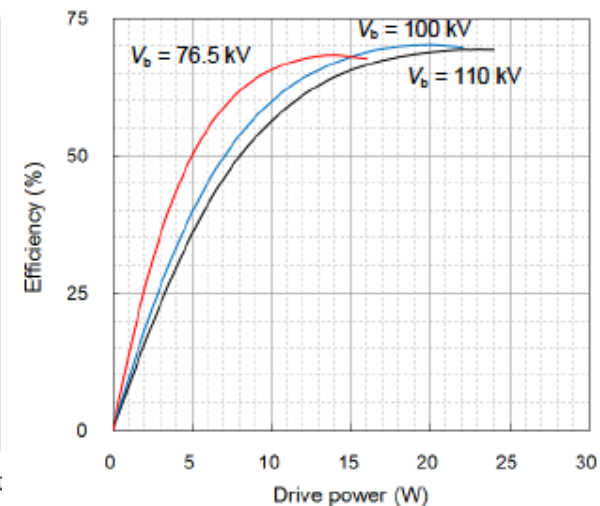

Toshiba klystron prototype E37504

- New development started in February 2015.
- The Toshiba klystron was tested at Factory in Japan in presence of ESS staff at the beginning of February 2016.
- Delivery took place on March 16th, two months ahead of schedule.
- Klystron is now in place at the Lund Test Stand, ready to be tested

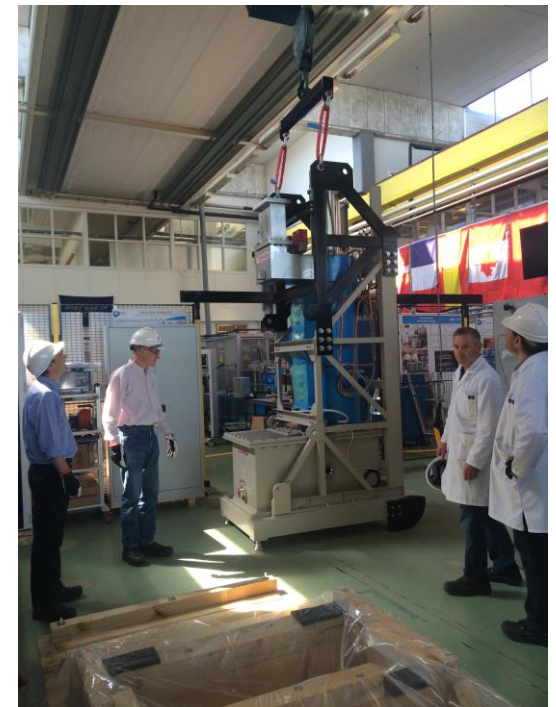

Toshiba klystron prototype E37504

- Compact design: 3.5 m including collector and gun tank
 - High gain (>47dB)
 - High efficiency (65%)
-
- ✓ Two electromagnet power supplies are required to provide current to the three focusing coils (one gun coil + two main coils):
 - ✓ Dispenser cathode
 - ✓ The output window is water cooled.
 - ✓ The tube can operate at low beam voltages (<85 kV) keeping high efficiency by using an output mismatch (Iris) and by changing the beam focusing

3.5 m

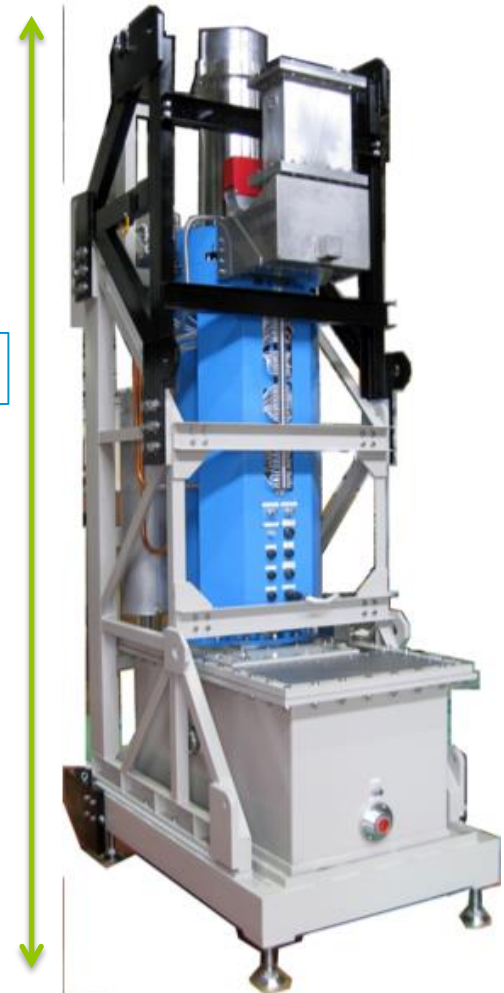

Toshiba klystron prototype: test results

Some results from the **Factory Acceptance Test** (February 2016):

Perveance measurements

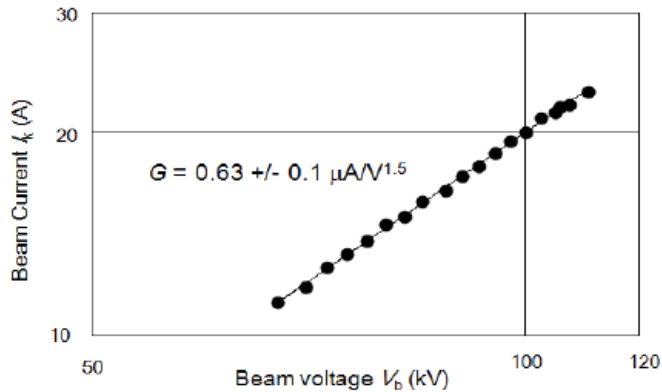

Beam pulse width 4.0 ms, Repetition rate 14 Hz ($I_{\text{sol1}} = 9.5 \text{ A}$, $I_{\text{sol2}} = 10.5 \text{ A}$)

Bandwidth

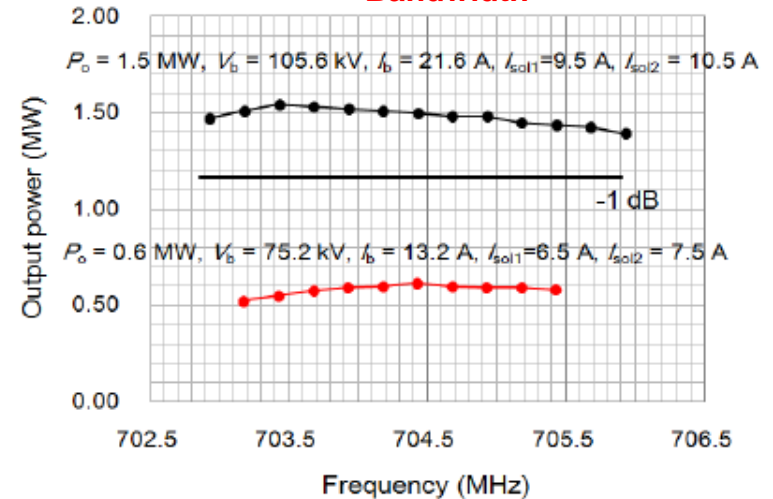

Waveforms at 1.5 MW output power

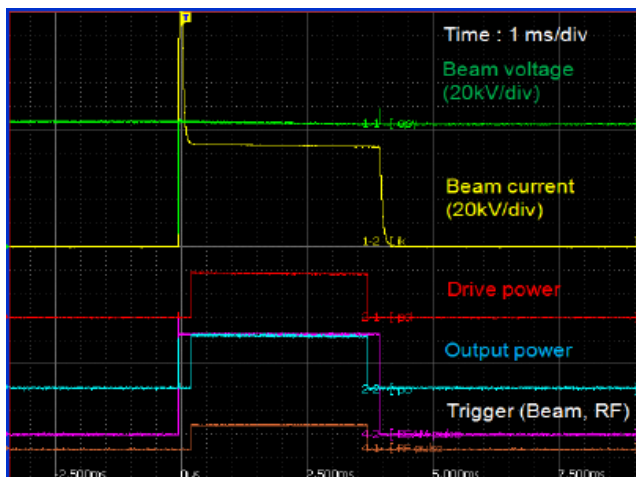

Efficiency of the klystron when operating on a mismatch with VSWR=1.2, any phase

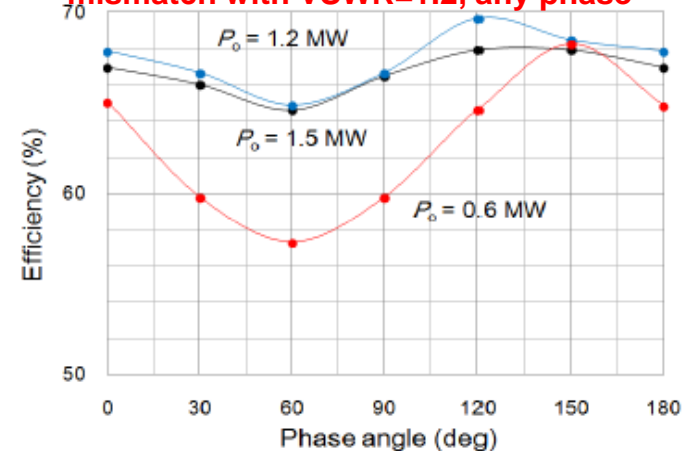

Courtesy of Toshiba

Toshiba klystron prototype: test results

Some results from the **Factory Acceptance Test** (February 2016):

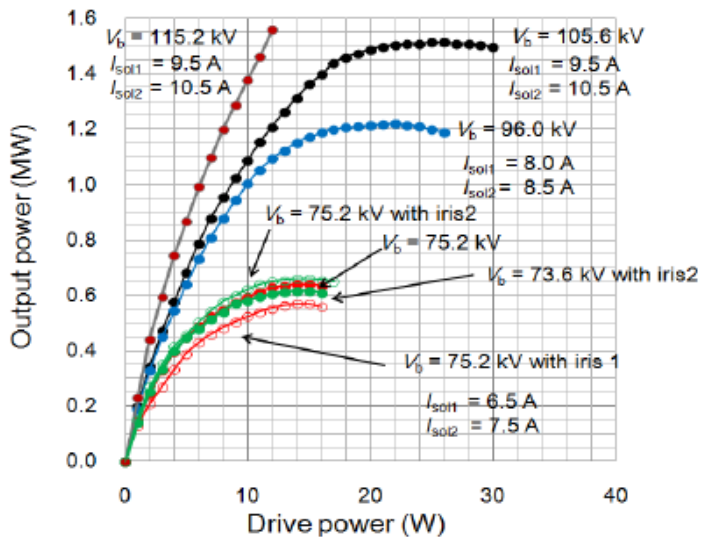
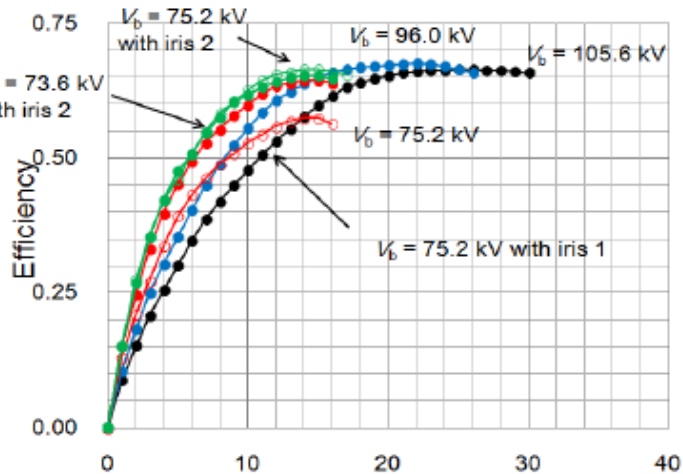

Efficiency and output power at nominal and at lower beam voltages with and without output mismatch. The solenoid current is also changed at low voltages

**Klystron
accepted and
delivered to
Lund!**



Thales klystron prototype TH2180

Based on the TH2182 developed for CERN (horizontal orientation)
Cern tube has been also tested at 1.7 ms, 2 Hz and 1.7 ms, 50 Hz
(Factory Acceptance Test)

- High gain (>47dB)
- High efficiency (>65%)
- Two electromagnet power supplies are required to provide current to the two focusing coils
- The output window is air cooled.
- The tube can operate at low beam voltages keeping high efficiency by using an output mismatch. The mismatch is provided through a post that can be inserted on the output waveguide (external to the X-rays shielding). Different posts can be used to optimize the tube performance at any operating voltage.

4.5 m

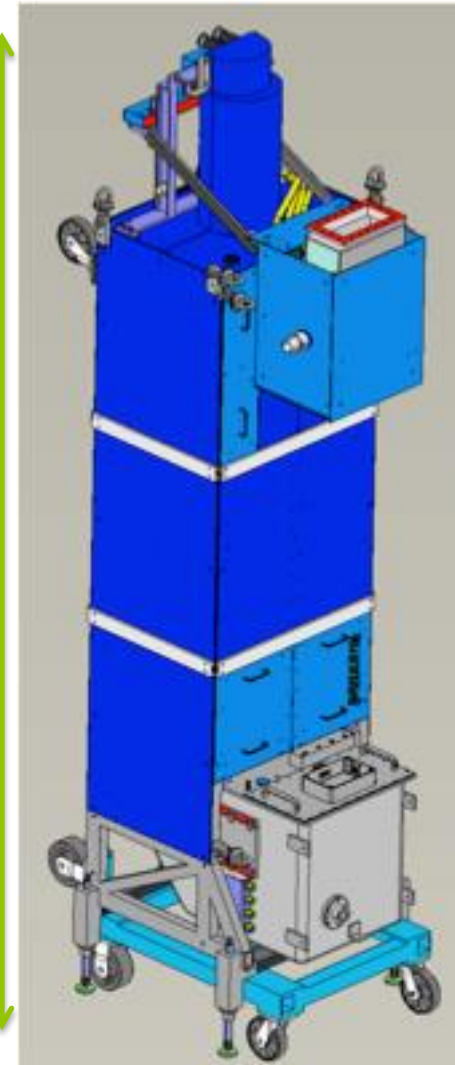

Courtesy of Thales

Thales klystron prototype TH2180

The tube has been tested at factory at full power for few days in May 2016. Saturated efficiency 66%.

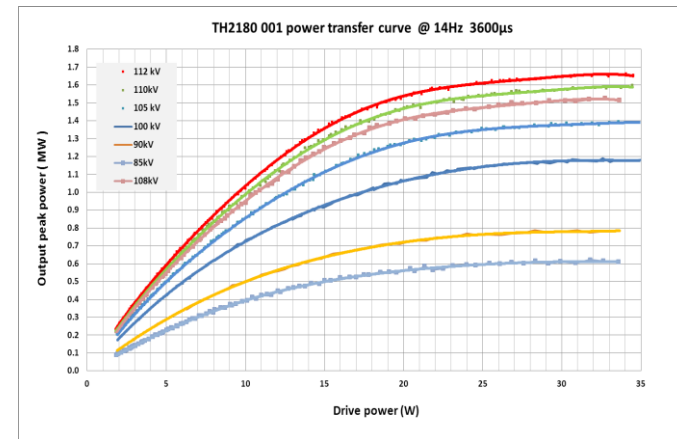
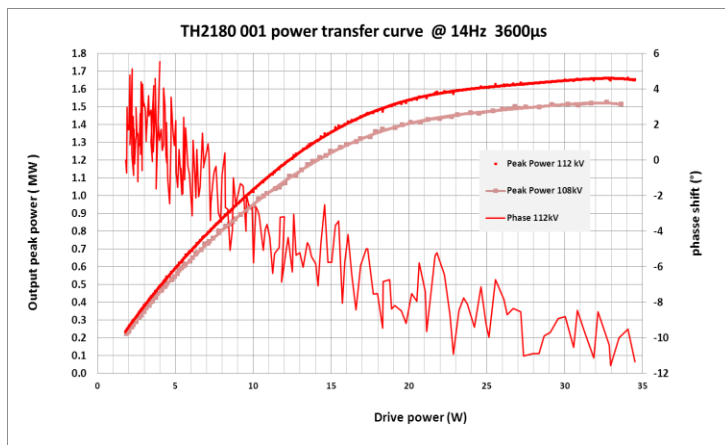

Courtesy of Thales

Operation at low beam voltage: efficiency can be increased by using a mismatch at the output (post). Preliminary results (can be improved):

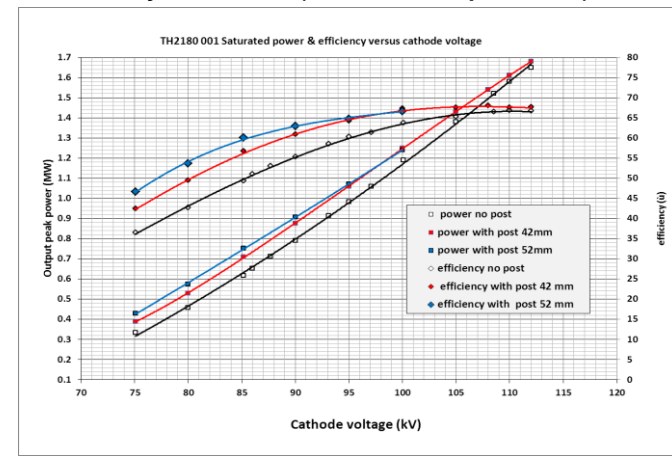
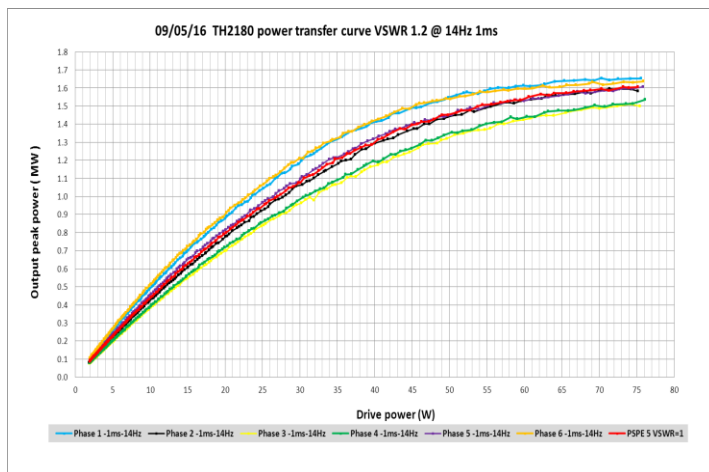

Thales klystron prototype TH2180

Factory Acceptance Test have not been performed yet due to problems arising in the RF output circuit:

when an event occurred, the RF output pulse was partially or completely truncated. In most cases, a vacuum trip was observed, and in some case the AFT arc detector pointing the window detected arcing.

Visual inspection revealed arcing activity due to a poor electrical contact in the output circuit.

The klystron is currently under repair. Delivery expected in August.

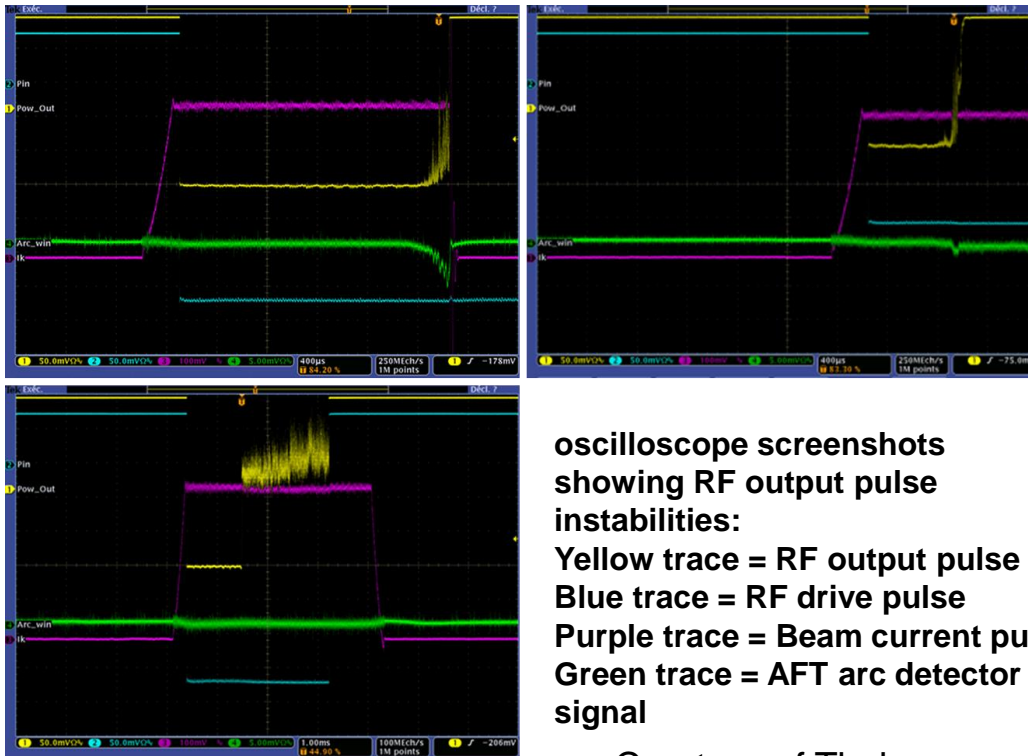

Courtesy of Thales



CPI klystron prototype VKP-8292A

New development based on CPI experience from the SNS klystrons

Courtesy of CPI

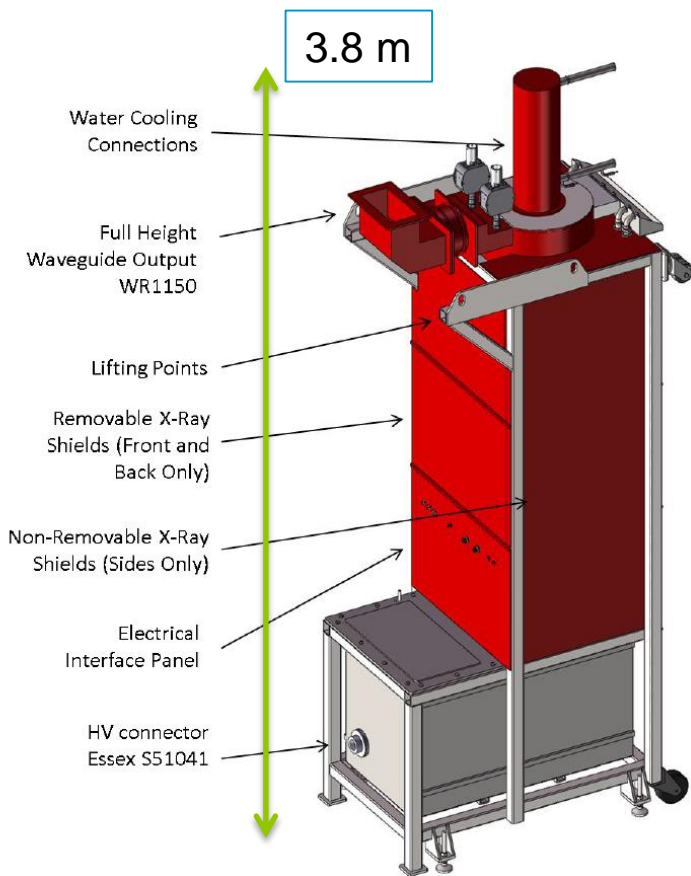

- Up to three electromagnet power supplies are required to provide current to the focusing coils
- The output window is air cooled

- The vacuum envelope has been sealed
- Tube dressed
- Testing is ongoing
- Delivery expected in August 2016



CPI klystron prototype VKP-8292A

Simulated performances:

Courtesy of CPI

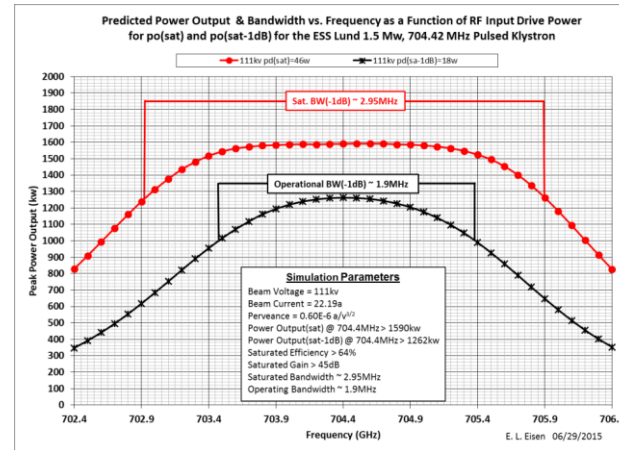
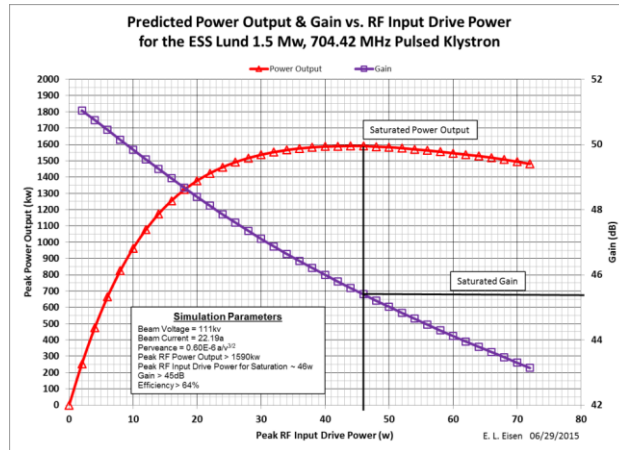

The tube can operate at low beam voltages keeping good efficiency by using an output mismatch.

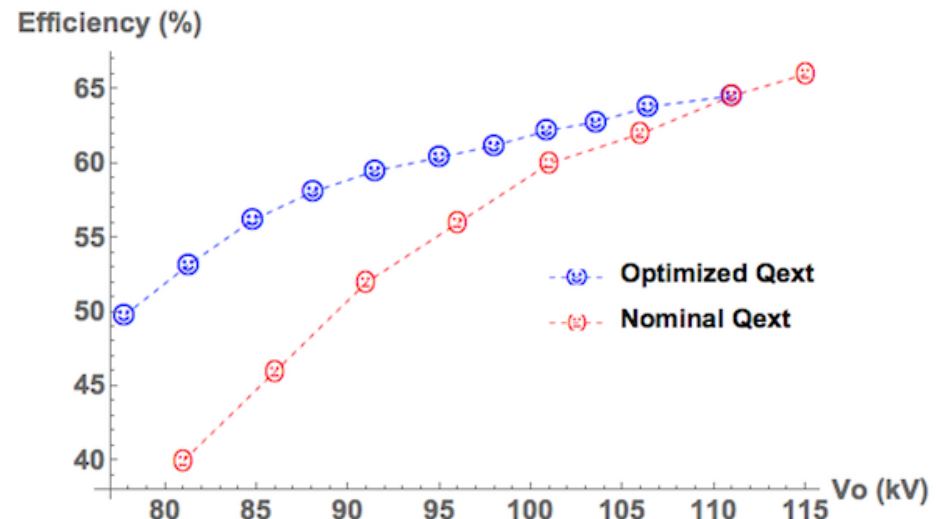
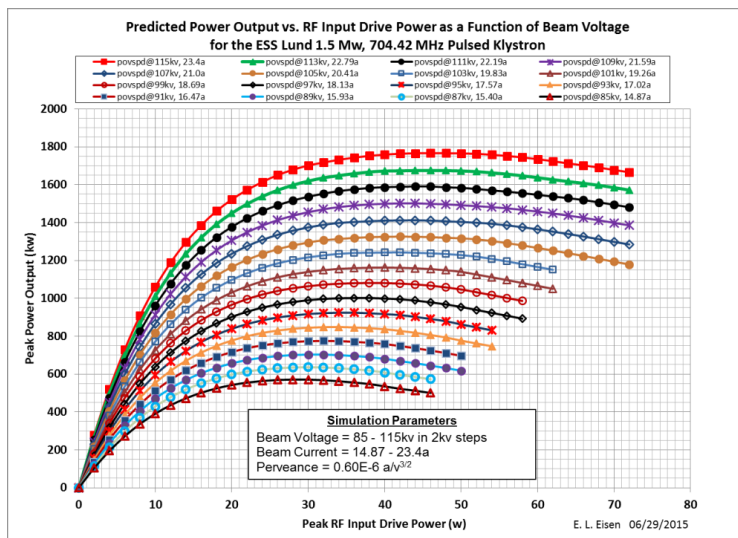

- The medium beta section represents the biggest part of the ESS linac for the 2019 deadline
- Prototyping of the high power amplifiers (klystrons) has been carried out:
 - Toshiba klystron prototype successfully tested and delivered to Lund
 - Thales klystron prototype to be delivered in august
 - CPI klystron prototype to be delivered in august
- Procurement of the series klystron to start in fall 2016

Thank you!

And thanks to:

- Toshiba Electron Devices
- Thales Electron Devices
- CPI

And the ESS RF group