

Characterization of Backgrounds in Lucas Cells

Elsbeth Cudmore – SNO+
CAP Congress 2016

First prize at SNOLAB summer student talk competition – August 2015



Laurentian University
Université **Laurentienne**



Carleton
UNIVERSITY

Introduction

- SNO+ is a neutrino physics experiment located 2km underground at SNOLAB.
- Detector comprised of a large acrylic vessel filled with LAB liquid scintillator, surrounded by UPW shielding and PSUP, holding ~9500 PMT detectors.
- Many internal backgrounds affect this experiment and need to be limited.

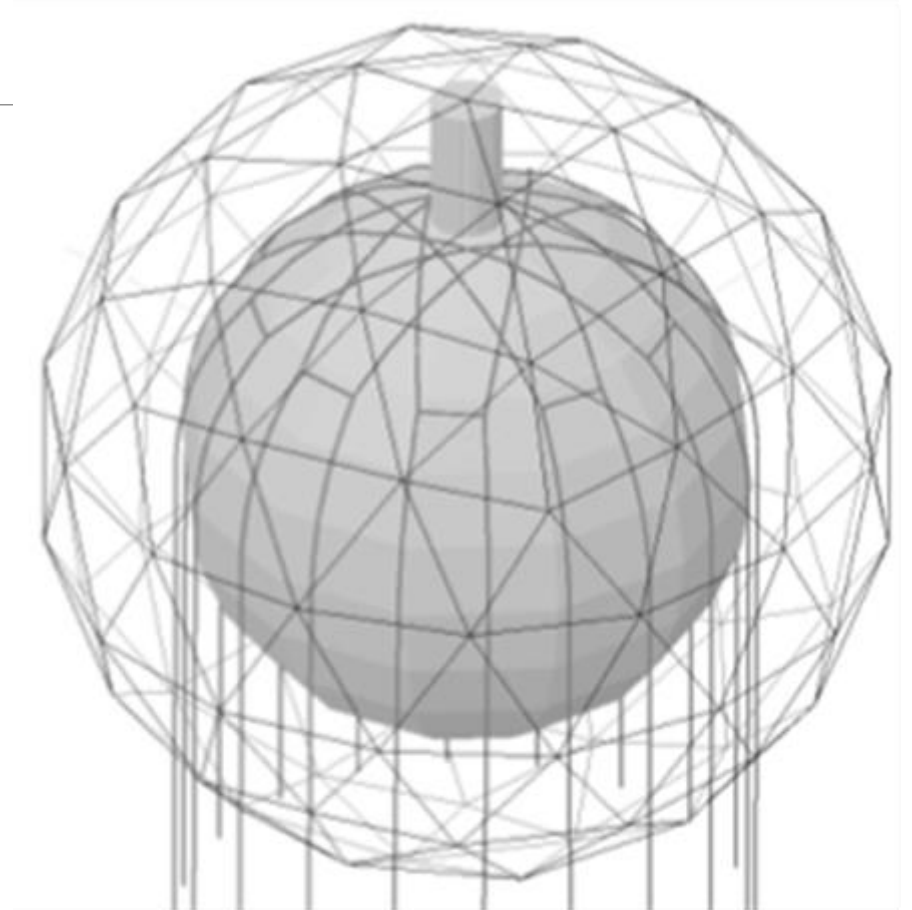

Some Background on Backgrounds

- Interfere with signals from the detector and can produce false signals
- Two decay chains of interest are U-238 and Th-232.
 - U-238 produces Bi-214 and other problematic backgrounds
- Can be determined by ‘counting’ Rn-222 emanating from a sample, and creating a counts per day value for said sample

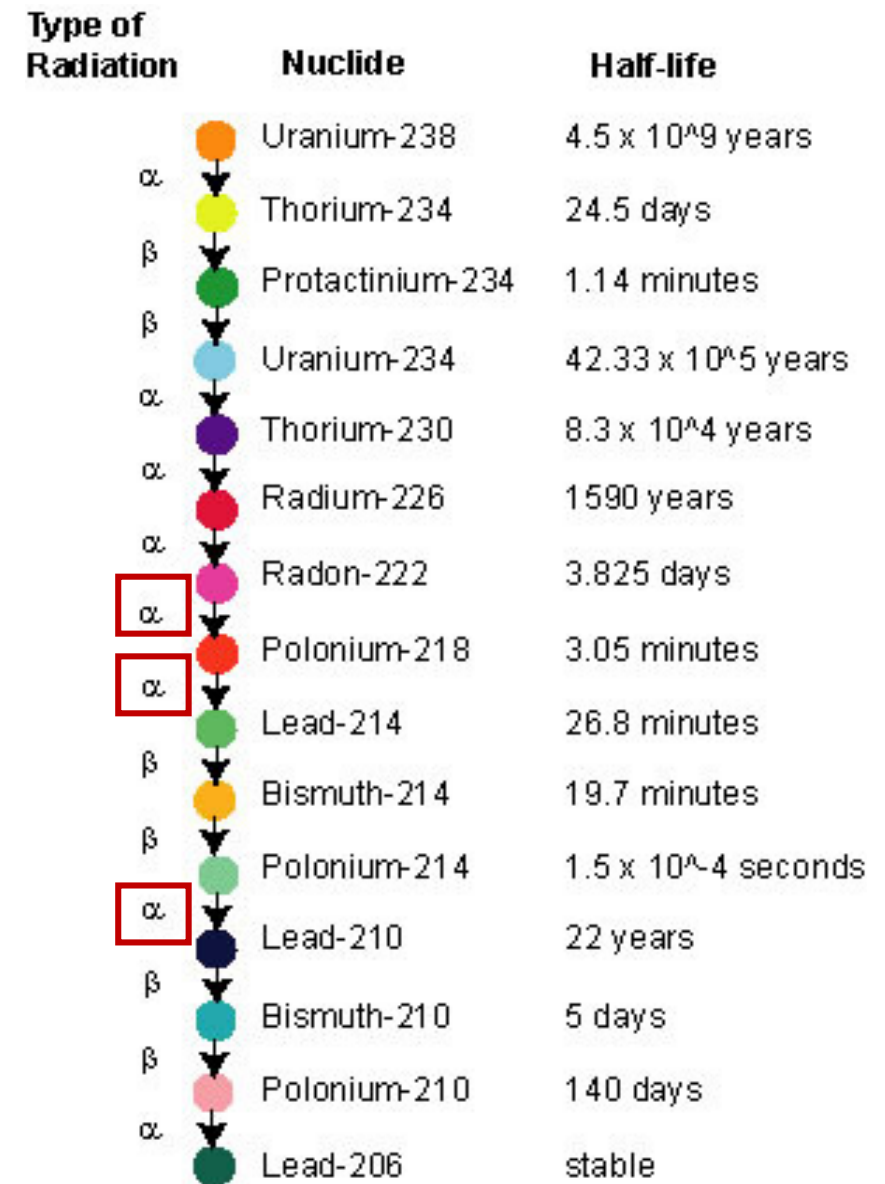

Figure 1: U-238 decay chain & notable alpha decays

SNO Lucas Cells

- Lucas Cells are used to collect Rn-222 emanating or dissolved in a sample in order to count backgrounds
- Old SNO Cells are still used but have developed their own background
 - Pb-210 and Po-210 buildup from many uses over many years
- To properly run radon emanation measurements, the backgrounds of the Lucas Cells must be known for counting

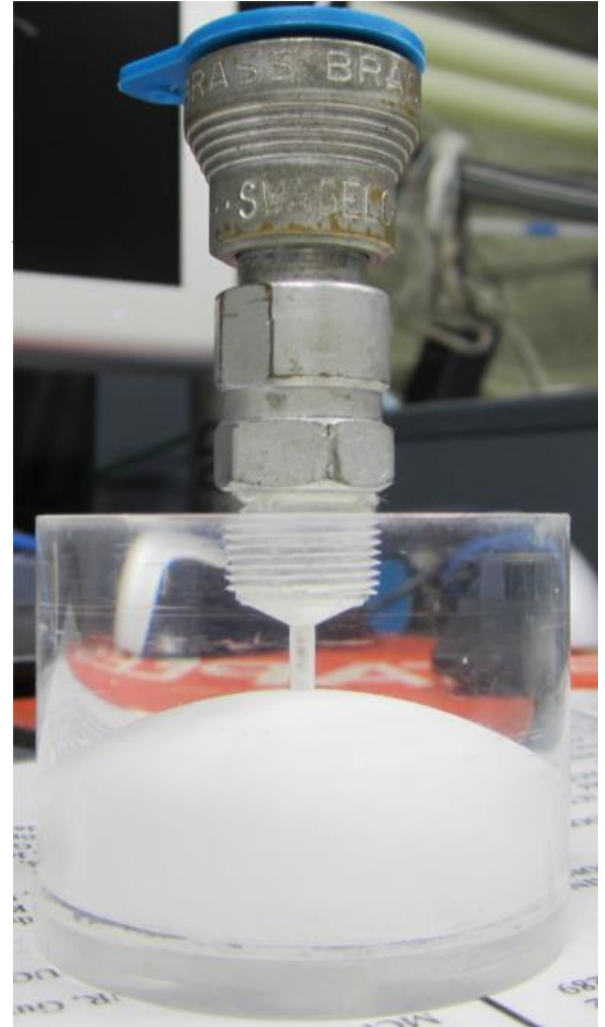

Figure 2: SNO Lucas Cell

Lucas Cell Geometry

- Made up of a small acrylic cylinder with a hemisphere chamber inside, coated with ZnS scintillator
 - Scintillator sensitive to α particles produced from decays
- Window at bottom of cell to allow PMT to see decay events

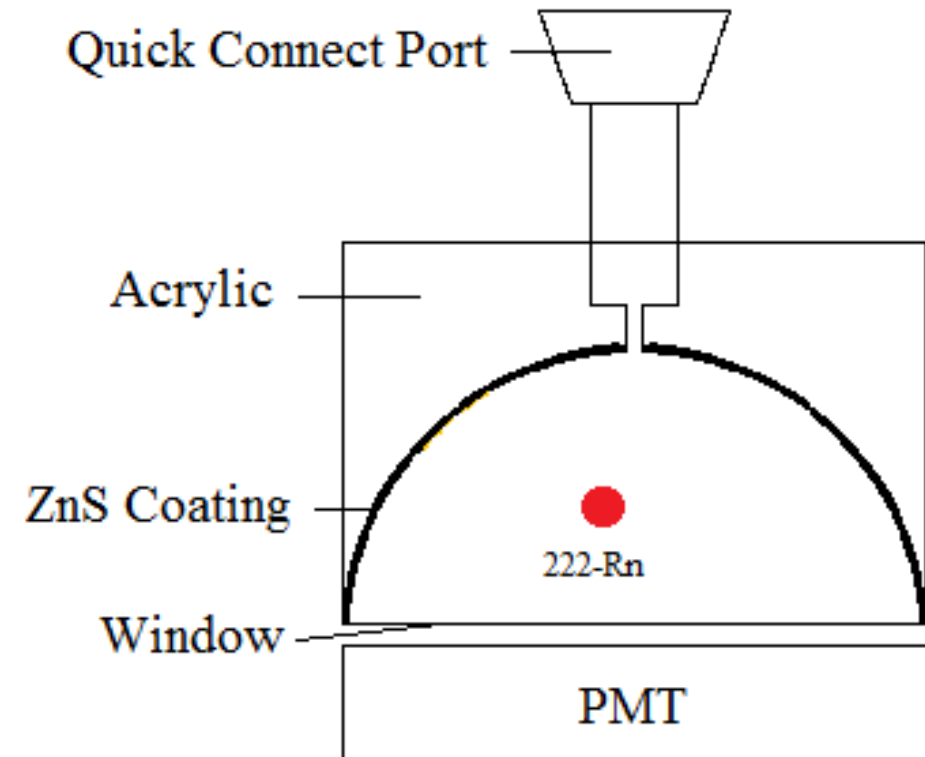

Figure 3: Scintillation in Lucas Cells

Evacuation of Cells

- Cells attached to underground mobile Rn Board, which is used to count radon emanation
- Vacuum is pulled on the cells
- Flushed with N₂, disconnected, and brought to surface for counting

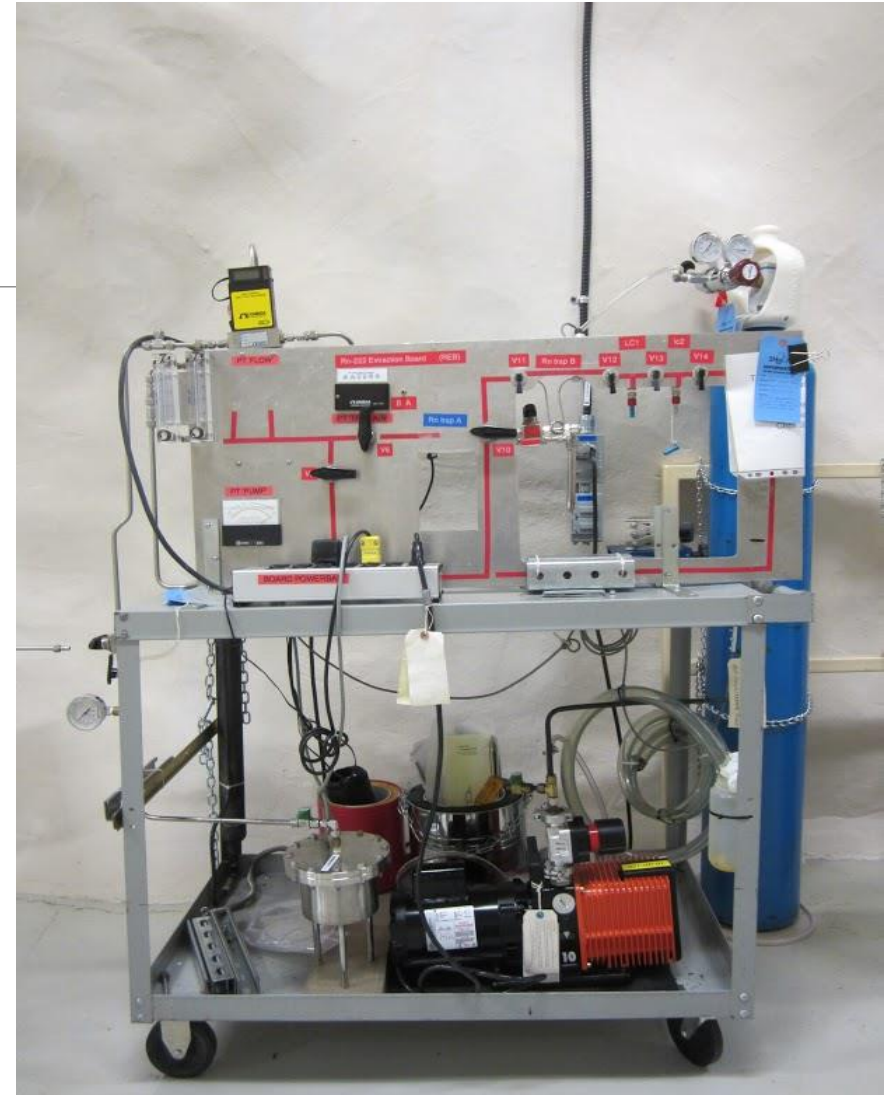

Figure 4: Underground Rn Emanation Board at SNOLAB

Counter Setup

- 4 free counters means that 4 cells can be run at once
- Lucas Cells placed in counters
 - Dark boxes containing a PMT
- PMT count impulses sent through system to DOS MultiTasker
- Outputs a .log file and a spectrum file

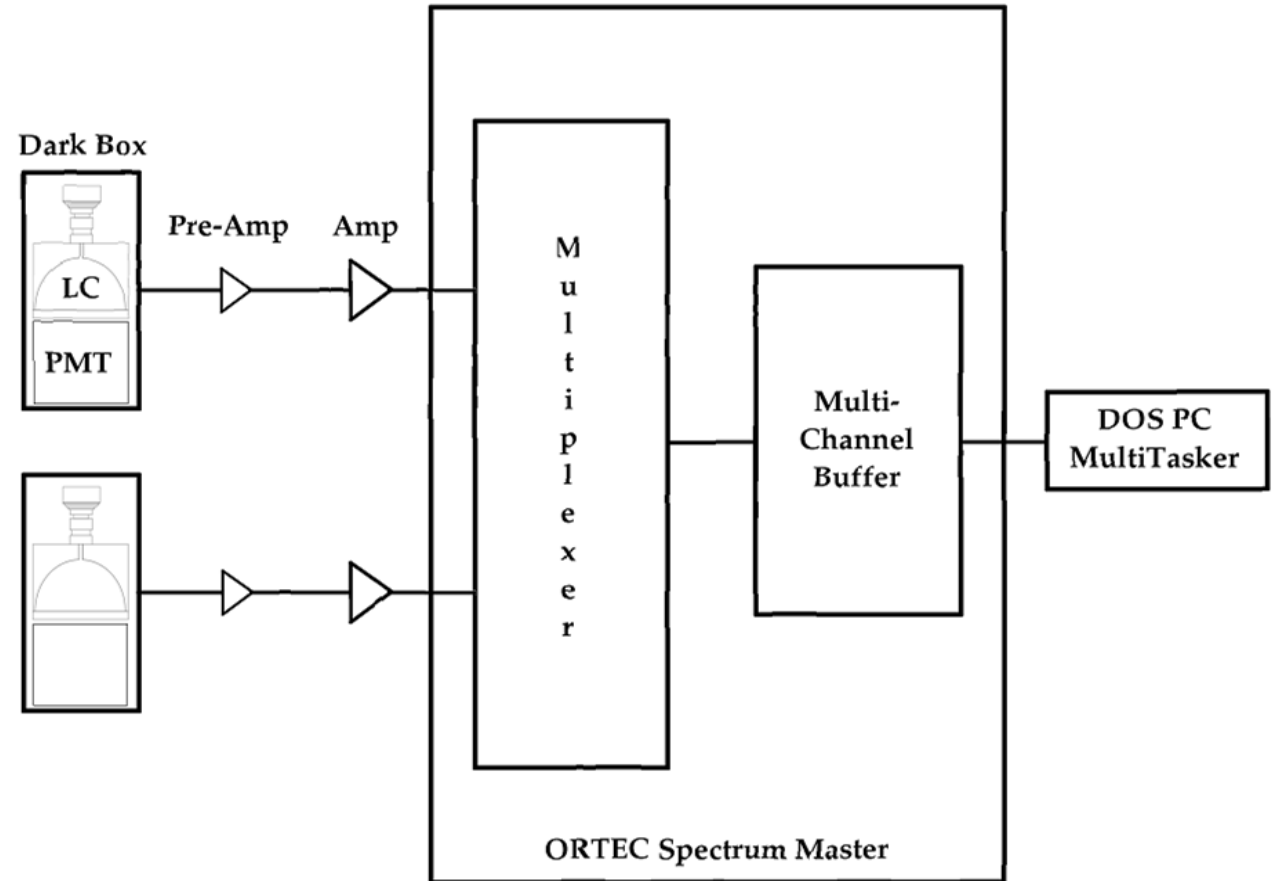

Figure 5: Lucas Cell Counter Setup

Summary of Runs

- Ideally allowed to run for 12 days
- 20 Cells completed in the summer of 2015
 - Found a large range of backgrounds, varying from ~25 CPD to ~2500 CPD
- Possibility of organizing cells for use based on their backgrounds
 - Specifically, using cells with stable/lower counts for emanation runs and water assays



Start Date (dd/mm/yyyy)	Log File ID (yymmddCH#)	PMT # --	Cell # --	Total Counts (Counts)	Error (√Counts)	Dt Count (hrs)	Dt Count (days)	Cell Bckgrnd (cpd)	Error (cpd)	Colour Code
<i>Previously Tested Backgrounds - Note that these were done with rounding throughout</i>										
05/09/2014	14090516	16	A14	1455	38.14	429	17.875	81.40	2.13	<10cpd
05/09/2014	14090514	14	N19	1083	32.91	429	17.875	60.59	1.84	10-100cpd
23/09/2014	14092309	9	A	3748	61.22	138	5.75	651.83	10.65	100-500cpd
23/09/2014	14092314	14	LCT5	45	6.71	138	5.75	7.83	1.17	500-1000cpd
23/09/2014	14092315	15	LCT4	40	6.32	138	5.75	6.96	1.1	500-1000cpd
23/09/2014	14092316	16	LCT6	37	6.08	138	5.75	6.43	1.06	>1000cpd

<i>Our Backgrounds - No rounding carried through calculation</i>										
03/07/2015	15070308	8	E	1526	39.06	266	11.08	137.68	3.53	
03/07/2015	15070309	9	F	27467	165.73	266	11.08	2478.23	14.96	
03/07/2015	15070314	14	H11	1324	36.39	266	11.08	119.46	3.28	
03/07/2015	15070315	15	H1	1997	44.69	266	11.08	180.18	4.03	
16/07/2015	15071608	8	LCT5	1005	31.70	179.57	7.48	134.32	4.24	
16/07/2015	15071609	9	N8	183	13.53	179.57	7.48	24.46	1.81	
16/07/2015	15071614	14	LCT4	188	13.71	179.57	7.48	25.13	1.83	
16/07/2015	15071615	15	A14	744	27.28	179.58	7.48	99.43	3.65	
23/07/2015	15072308	8	L16	44	6.63	283.95	11.83	3.72	0.56	
23/07/2015	15072309	9	L11	3	1.73	283.95	11.83	0.25	0.15	
23/07/2015	15072314	14	H4	4054	63.67	283.95	11.83	342.65	5.38	
23/07/2015	15072315	15	A	7787	88.24	283.95	11.83	658.17	7.46	
04/08/2015	15080408	8	A4	101	10.05	307.65	12.82	7.88	0.78	
04/08/2015	15080409	9	C	0	0.00	307.65	12.82	0.00	0	
04/08/2015	15080414	14	15	538	23.19	307.65	12.82	41.97	1.81	
04/08/2015	15080415	15	H9	4117	64.16	307.65	12.82	321.17	5.01	
17/08/2015	15081708	8	H7	4625	68.01	161.26	6.72	688.33	10.12	
17/08/2015	15081709	9	N19	88	9.38	161.26	6.72	13.10	1.4	
17/08/2015	15081714	14	N9	6770	82.28	161.26	6.72	1007.57	12.25	
17/08/2015	15081715	15	N10	105	10.25	161.26	6.72	15.63	1.52	

Interesting Findings

Colour Code
<10cpd
10-100cpd
100-500cpd
500-1000cpd
>1000cpd

- The change of backgrounds over time with Cells A14, LCT4 and LCT5

Start Date (dd/mm/yyyy)	Log File ID (yymmddCH#)	PMT # --	Cell # --	Total Counts (Counts)	Error ($\sqrt{\text{Counts}}$)	Cell Bckgrnd (cpd)	Error (cpd)
05/09/2014	14090516	16	A14	1455	38.14	81.40	2.13
16/07/2015	15071615	15	A14	744	27.28	99.43	3.65
23/09/2014	14092315	15	LCT4	40	6.32	6.96	1.1
16/07/2015	15071614	14	LCT4	188	13.71	25.13	1.83
23/09/2014	14092314	14	LCT5	45	6.71	7.83	1.17
16/07/2015	15071608	8	LCT5	1005	31.70	134.32	4.24

Interesting Findings (cont'd)

Colour Code
<10cpd
10-100cpd
100-500cpd
500-1000cpd
>1000cpd

- The ridiculously high counts for Cell F (~2500 CPD)
- Lowest accepted counts from Cell L16 (3.72 CPD)
- Possibility of broken counter due to extremely low detection in cells L11, C, and N19

Start Date	Log File ID	PMT #	Cell #	Total Counts	Error	Cell Bckgrnd	Error
(dd/mm/yyyy)	(yymmddCH#)	--	--	(Counts)	($\sqrt{\text{Counts}}$)	(cpd)	(cpd)
23/07/2015	15072309	9	L11	3	1.73	0.25	0.15
04/08/2015	15080409	9	C	0	0.00	0.00	0
05/09/2014	14090514	14	N19	1083	32.91	60.59	1.84
17/08/2015	15081709	9	N19	88	9.38	13.10	1.4

Mapping Low Count Cell (L16)

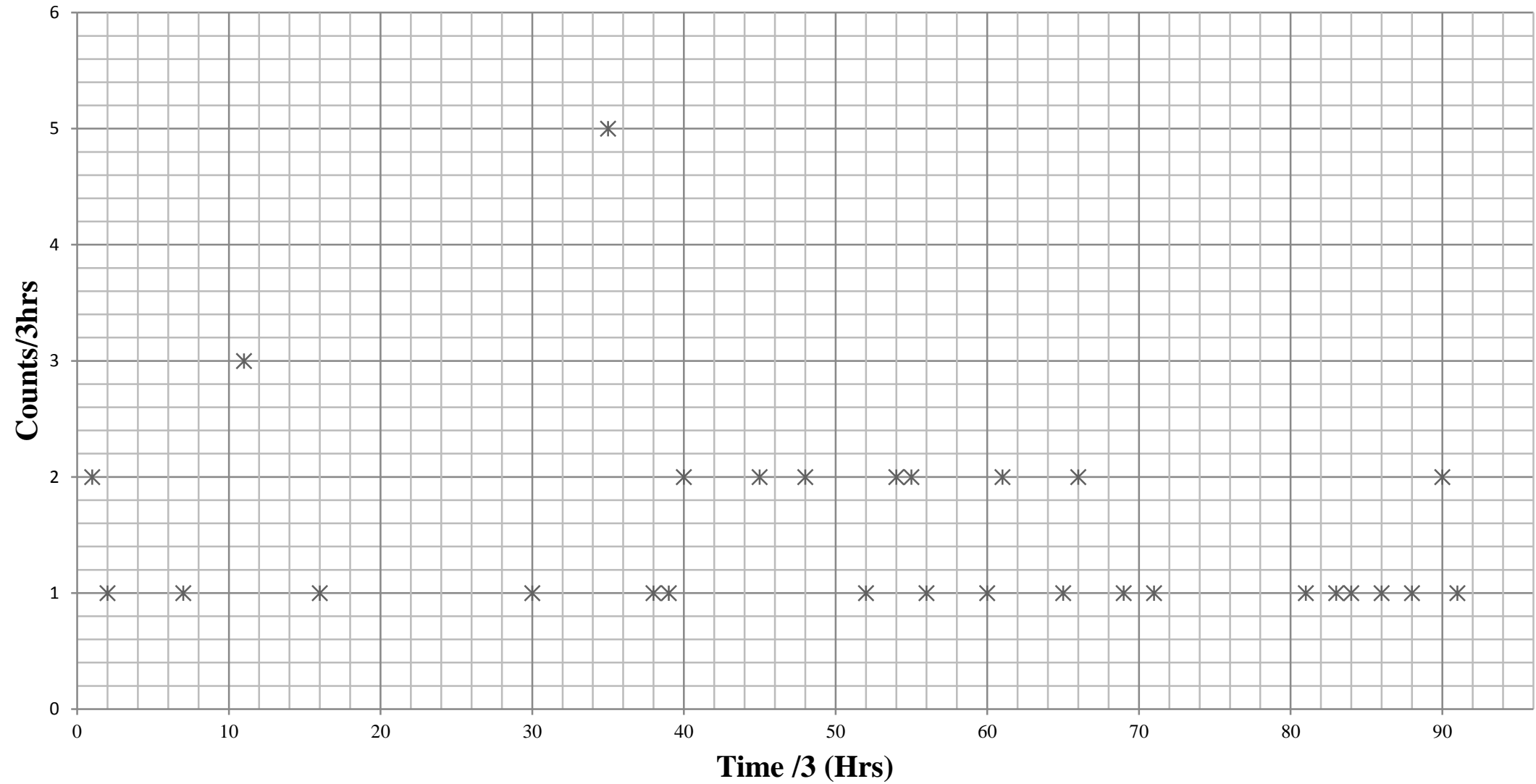

Mapping High Count Cell (F)

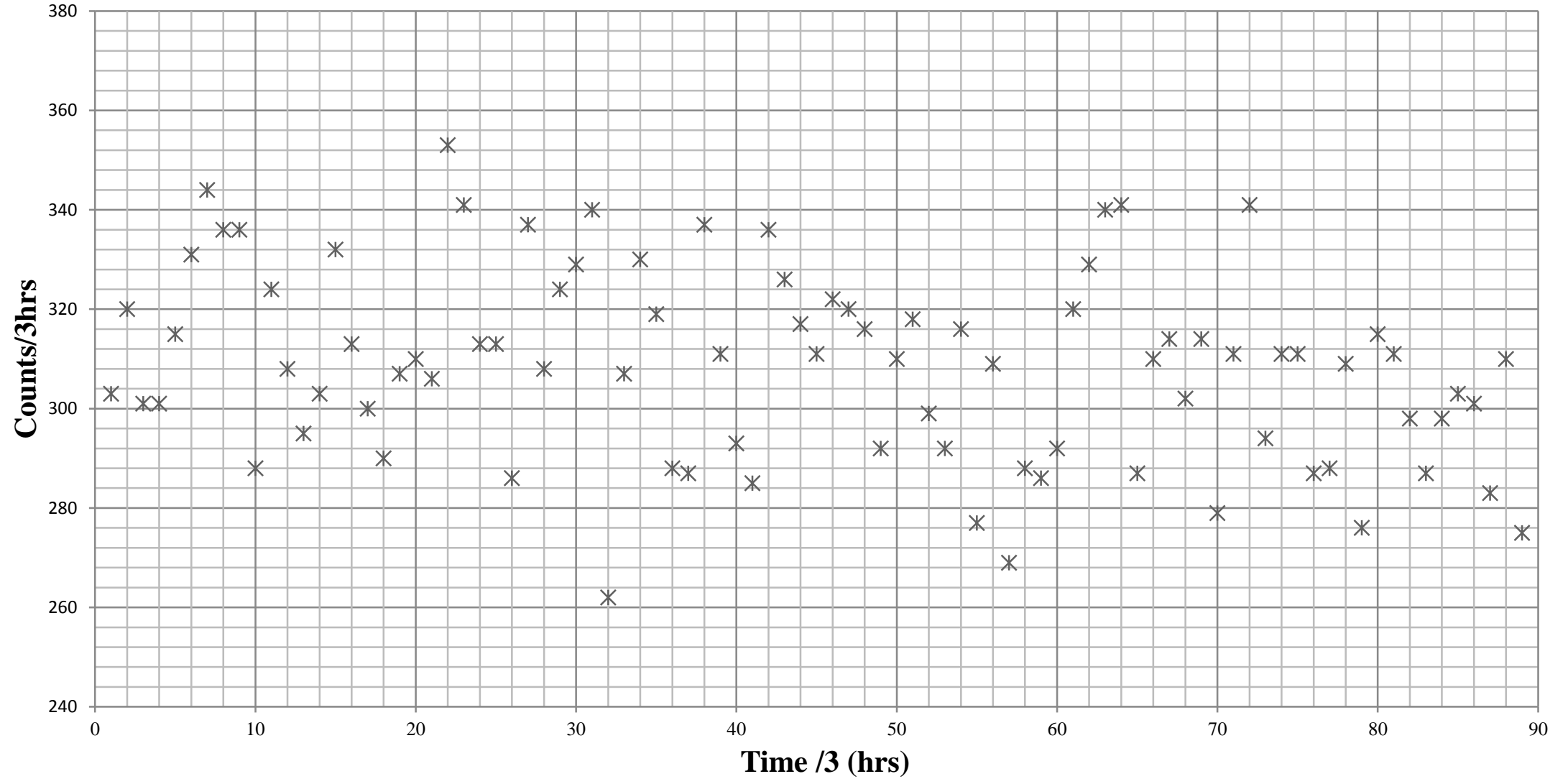

Mapping Suspected Leaking Cell (N9)

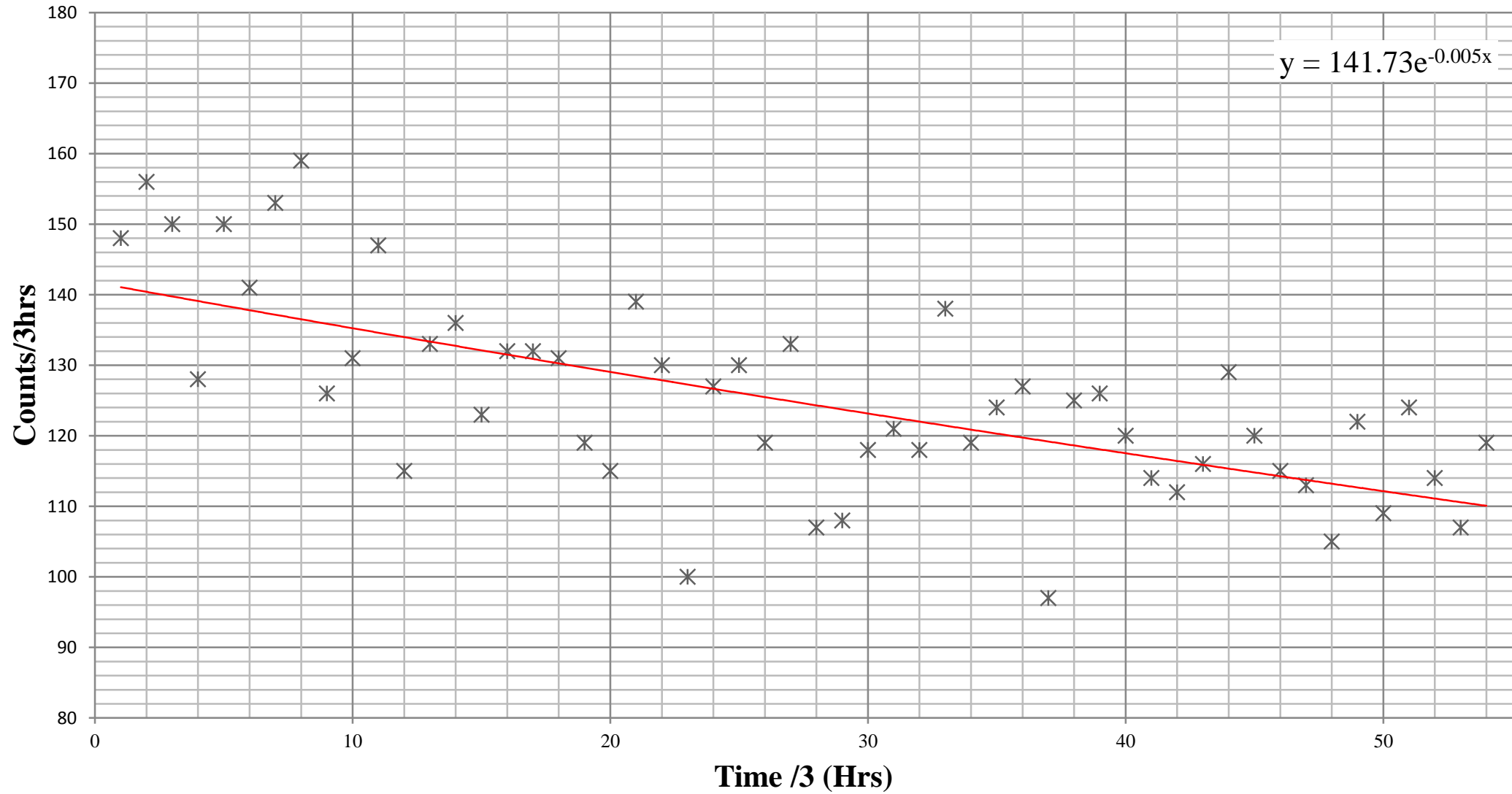

Future Lucas Cell Work

- Completion of Lucas Cell Background Counts
- Renaming cells and regularly checking backgrounds
- New surface emanation board being created on surface at SNOLAB

Thanks!

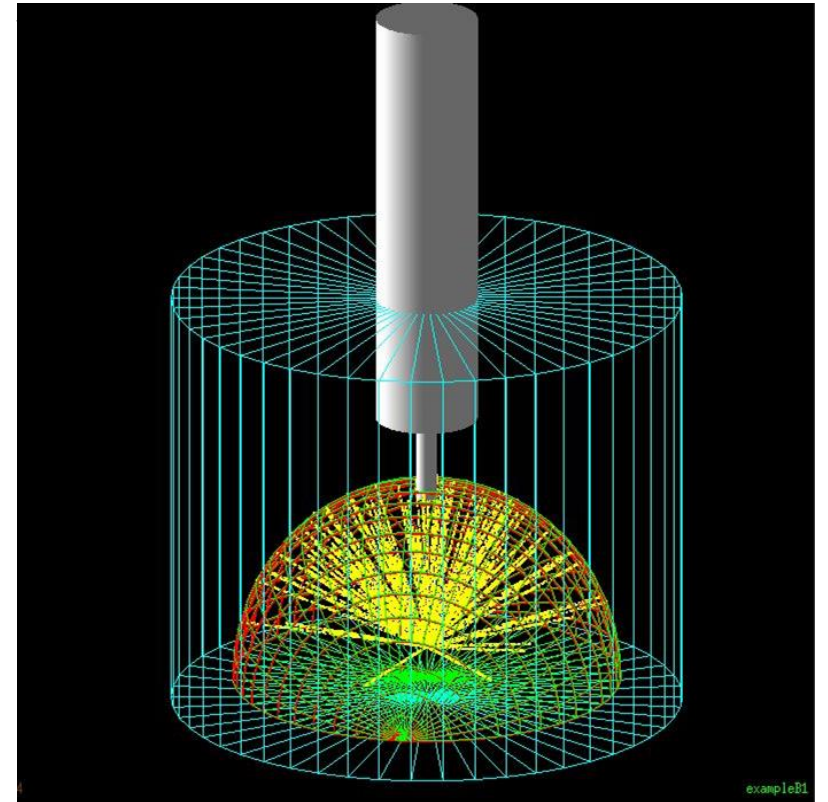

Figure 6: Geant4 Simulation of Cell, provided by C. Connors