

Studies for Developing the MW-station Ion Source

A compact and efficient design to get 10^{15} fissions/s

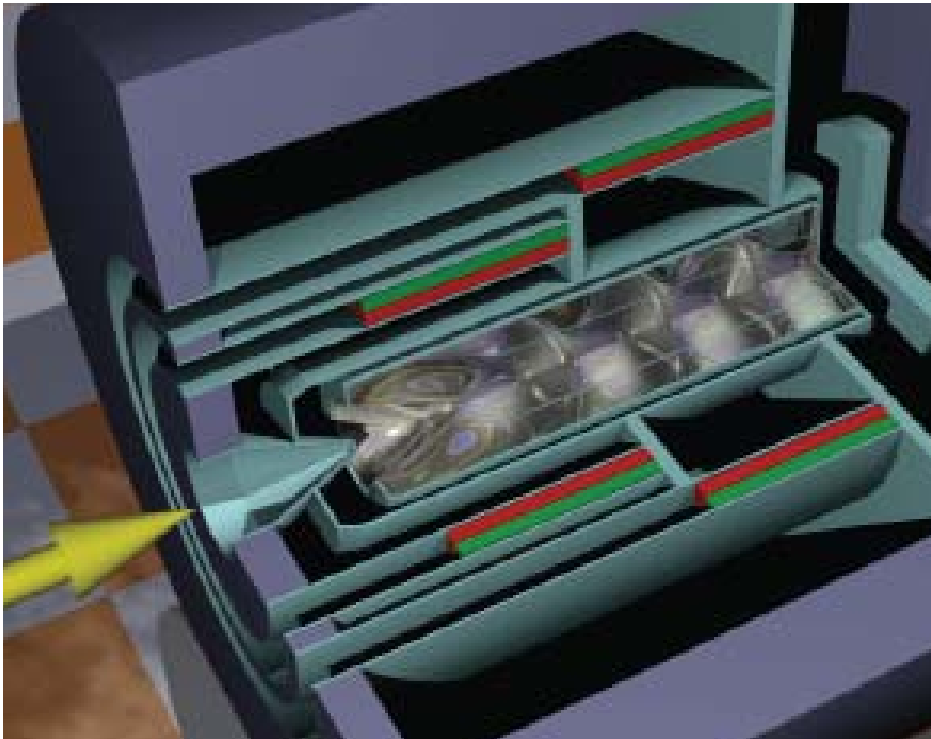

- * Cylindrical liquid Hg converter (~10 l.)
- * Surrounding annular fission target (~5 l.)

The annular fission target split up
in 8 independent fission targets

- * 8 x 1,6 kg of Uranium
- * standard UC_x (3 g/cm^3 of U).

Overall issues

- How to connect ion source to such a target system?
 - **Multiple ion sources?** Acceptable for the design of radioactive beam line?
 - **Multiple transfer lines?** Cf. Thierry STORA's presentation.
- What kind of ion source?
 - Capable of operating under the **vapour from the bulky target**.
 - Capable of **withstanding the level of radiation** generated close to the target.

Basic scheme

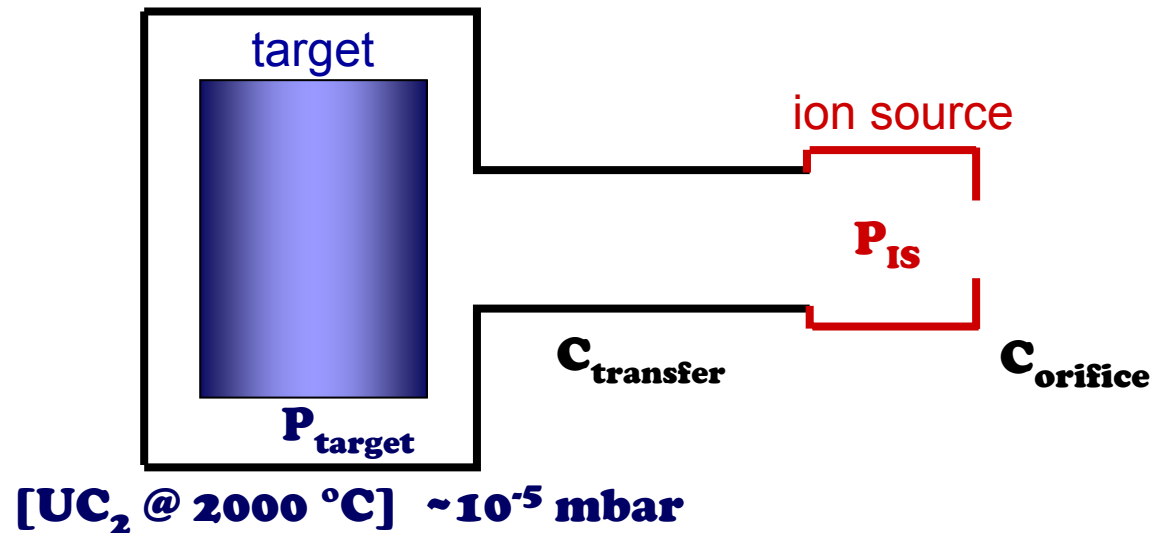

$$Q = C \times \Delta P \quad \text{with } C \text{ order of 1 l/s. (molecular flow)}$$

$$\sim 10^{-6} < P_{IS} < \sim 10^{-5} \text{ mbar} \rightarrow Q_{out} < \sim 10^{-5} \text{ mbar.l/s (negligible)}$$

$$\rightarrow P_{IS} \sim P_{target}$$

If no specific device on transfer line, most target out-gassing goes into the ion source.

Considering a piece of 1/8 target
(1,6 kg of nat.U):

- Overall radioactive nuclei production
 $\sim 10^{16}$ nuclei/s in target; if 10% released
 $\rightarrow \sim 10^{15}$ nuclei/s $\Leftrightarrow \sim 10^{-4}$ mbar.l/s

- Stable out-gassing

UC₂ out-gassing is dominant (x100 larger than Ta out-gassing);

Target surface at least x10 wider than standard

$\rightarrow > 10^{-1}$ mbar.l/s (equilibrium) only a part reaches the ion source.

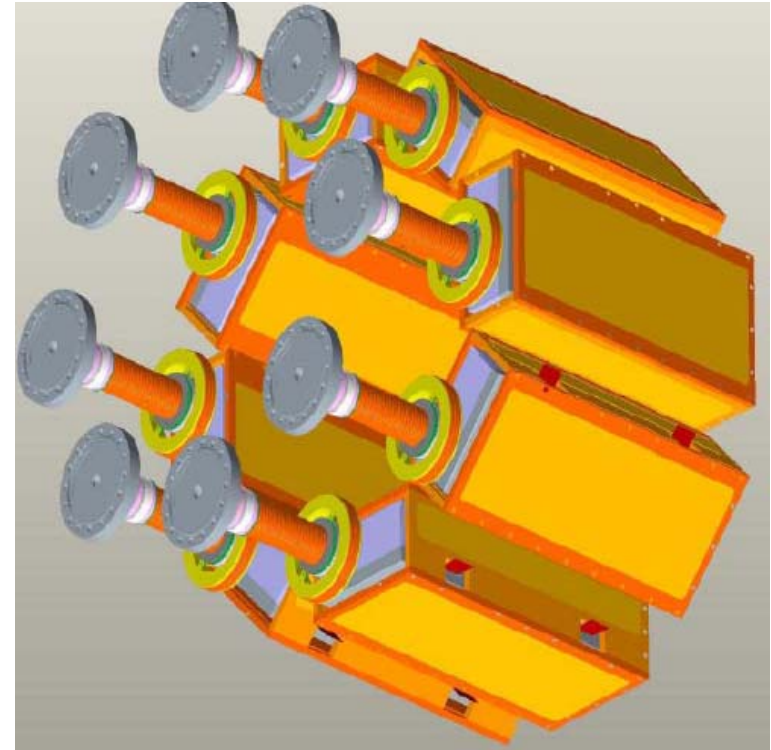

What kind of ion source?

- **Target out-gassing surface is a few x10 wider than standard**
- **for efficient ion sources** ($\epsilon_{\text{ion}} \sim 1\%$): **total extracted beam ~mA**
- **ion source close to the target** → 10^{14} neutrons/cm²/MW of beam

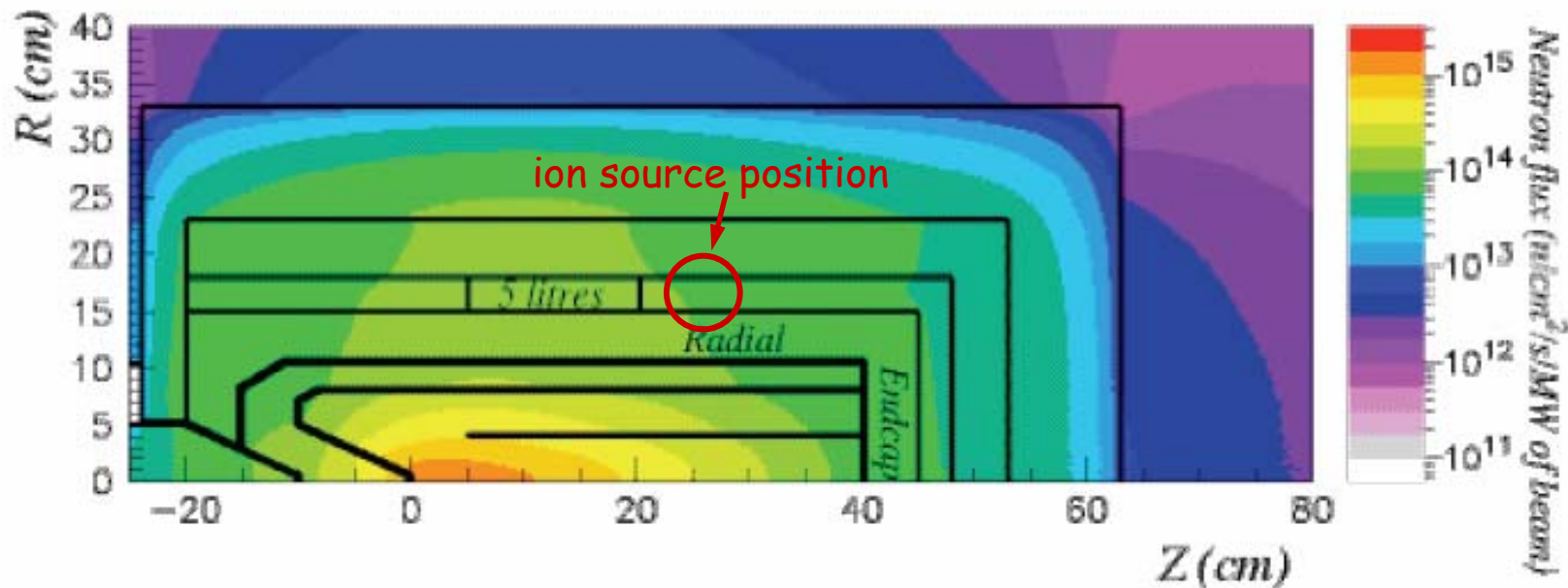

A. Herrera-Martinez et al.

What about ECRIS?

- OK for operating with such out-gassing conditions
- Possibility of transfer-line cooling to reduce metal vapours
- RF injection issue
- Radiation damage of magnetic confinement system:
 - Possibility of using coils instead of permanent magnets
 - Radiation damage of insulators? e.g. glass fibres ~10 MGy

Such studies are in progress for SPIRAL-2...

FEBIAD-type Ion Source ?

- Not dedicated for operating with high vapour flow:
 - Standard FEBIAD operate up to 10^{-3} mbar.l/s
 - EGBP (radial type, by J.M. Nitschke) up to 10^{-4} mbar.l/s
- Nielsen and Nier-Bernas ion sources can operate:
 - e.g. beams of a few mA with an emittance of 20π .mm.mrad @ 40 kV.
 - **But quick wearing of the cathode.**
- Radiation damage of the refractory insulators
 - {cathode/anode} → **need of refractory insulators close to ionization chamber.**

→ IRENA prototype

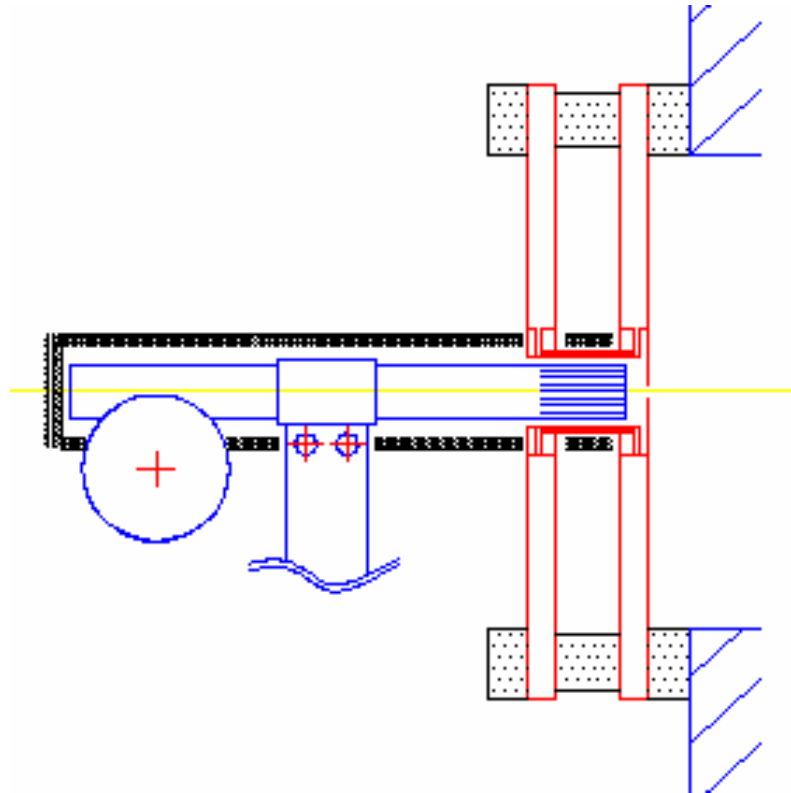

Main features:

- **Minimum of components (no magnet!)**
- **Insulators away from the ion. chamber**
- **Radial cathode more reliable**

Cathode Design

- ↘ **hazard of cathode/anode short**
- ↘ **residual pressure in chamber**
- **strong e- emission required**

IRENA prototype based on EBG (Nitschke, LBL 1985).

IRENA 1st prototype: First results (1)

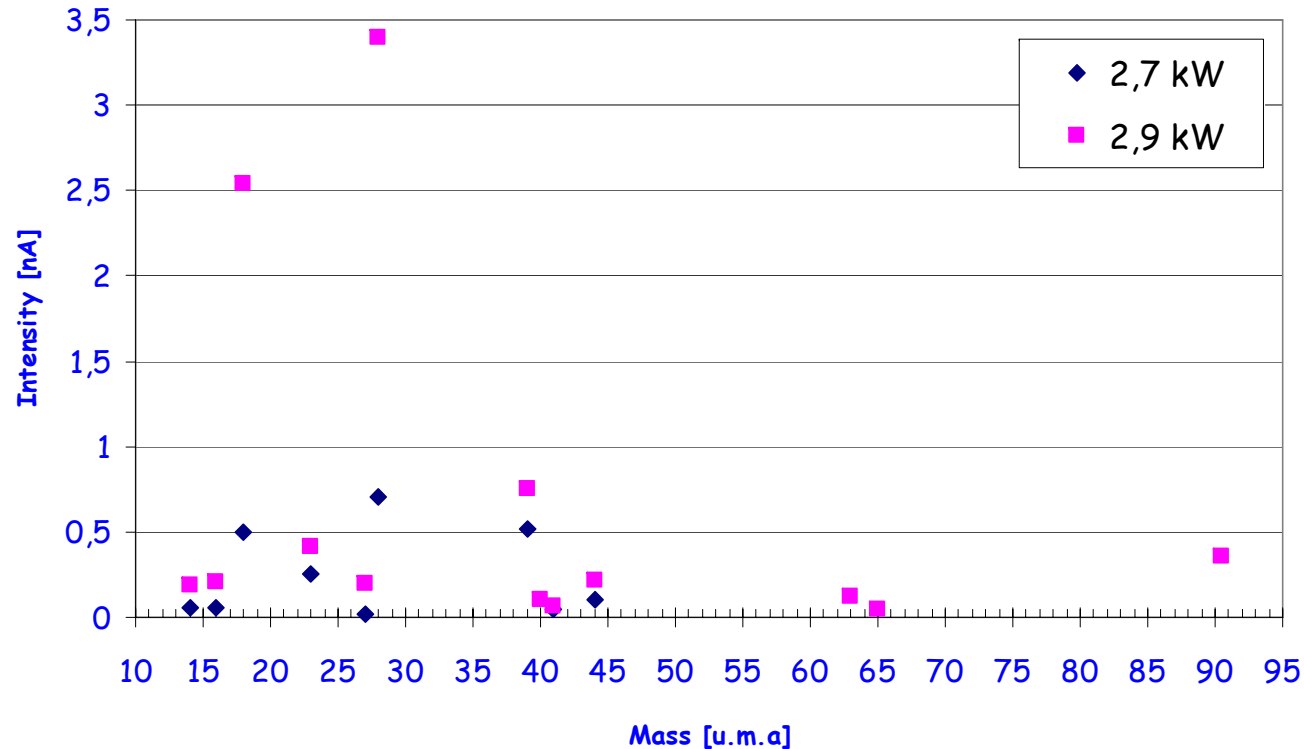

Optimal conditions not yet reached: ionization efficiency (Kr): 0.03 % @ $2 \cdot 10^{-5}$ mbar.

Tests interrupted in March 06; to be pursued with a prototype supplied by NIPNE.

IRENA 1st prototype: First results (2)

Total beam extracted @ 10^{-5} mbar as function of cathode heating.

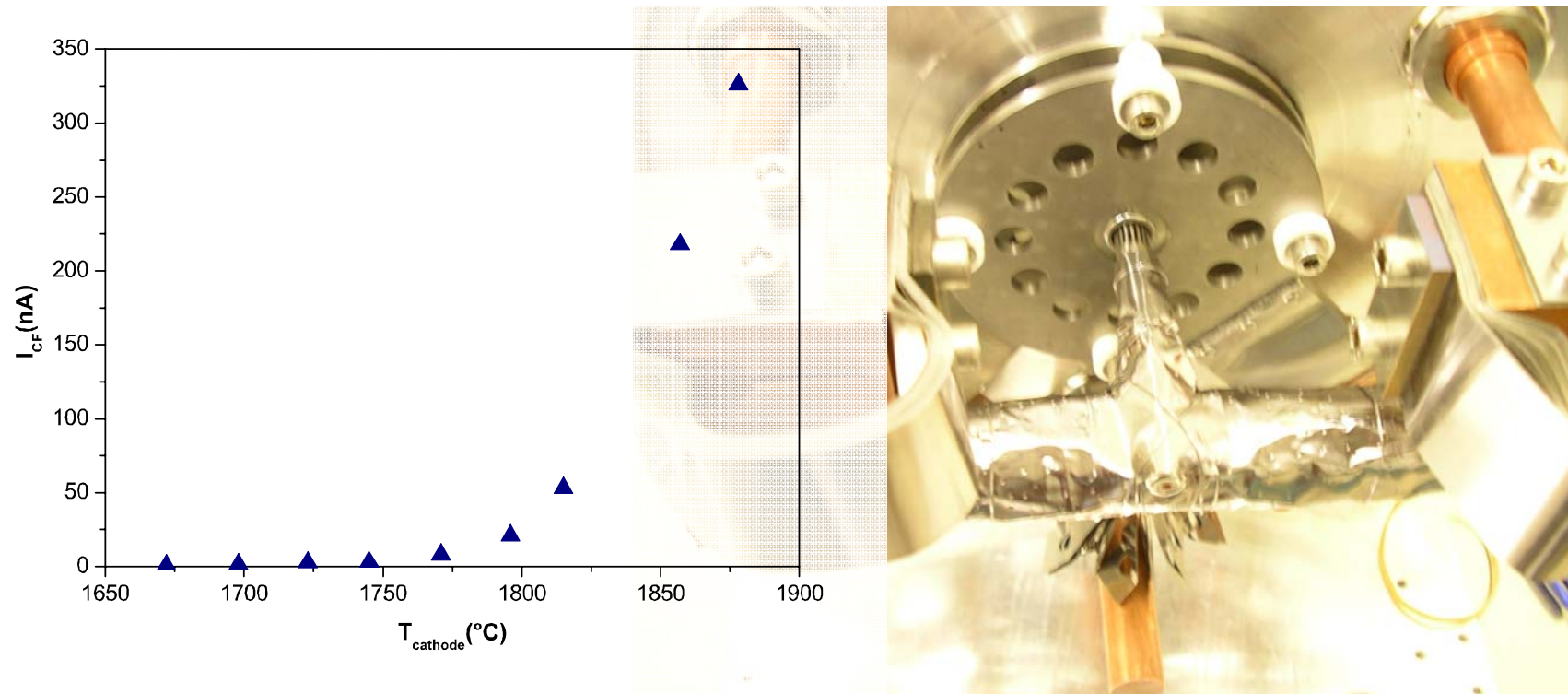

**Total beam intensity comparable to EBGP ($\sim \mu\text{A}$)
expected by 2000 °C within these operation conditions.**

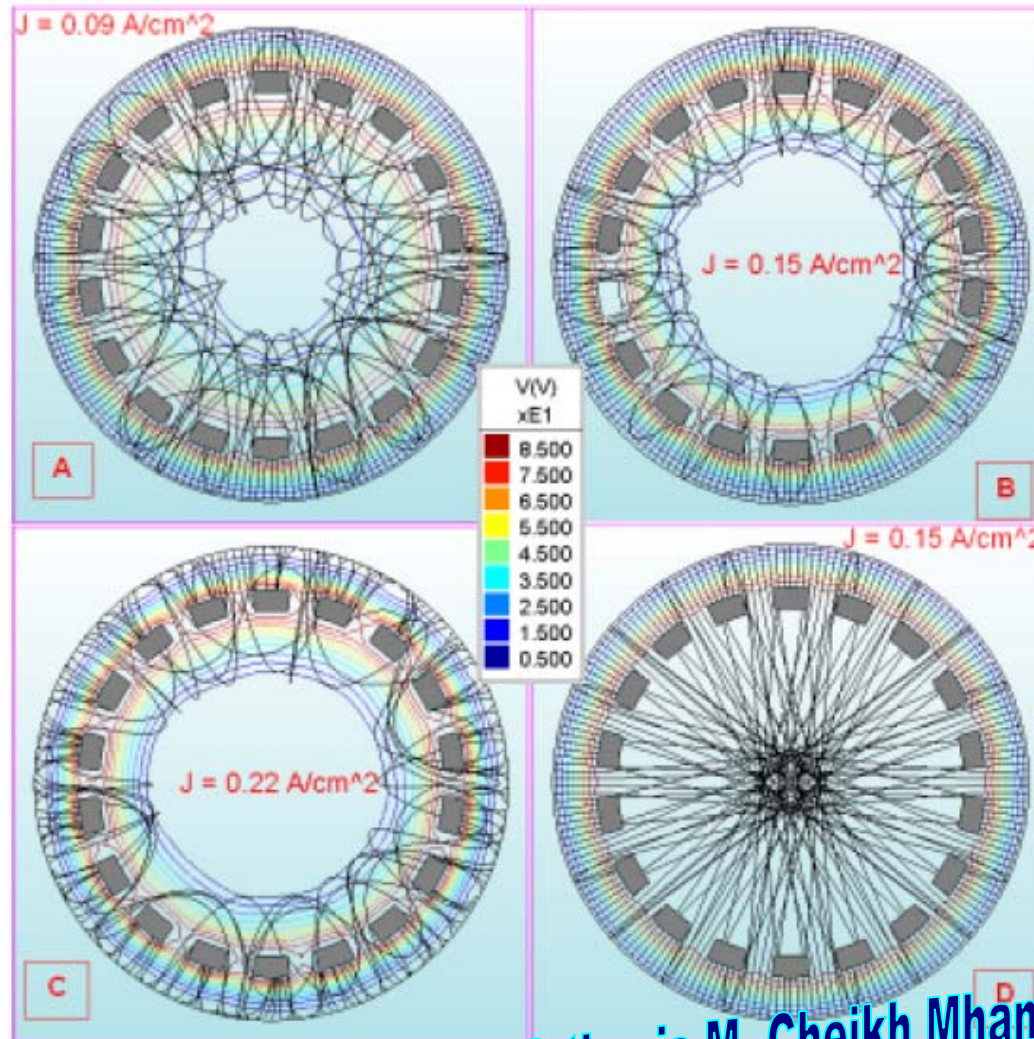

Increasing e^- emission by 10^3 to get a prototype working with MW-target out-gassing.

→ Another cathode material or cathode surface $\times 10^3$

(the ionization chamber may reach the typical size of **ECRIS**)

Further studies using IES Lorentz code planned in 2007.

Ph.D thesis M. Cheikh Mhamed

What about RILIS?

- High pressure in the hot cavity
 - Larger production of non-selected positive ions
 - Deterioration of the plasma conditions in the cavity
- Possible remedy
 - Increasing cavity diameter (keeping $\varnothing/L^2 \sim \text{constant}$)
 - larger conductance and larger surface for increasing e- emission.
 - Changing cavity material to increase e- emission.
 - Or...

a plasma confinement structure

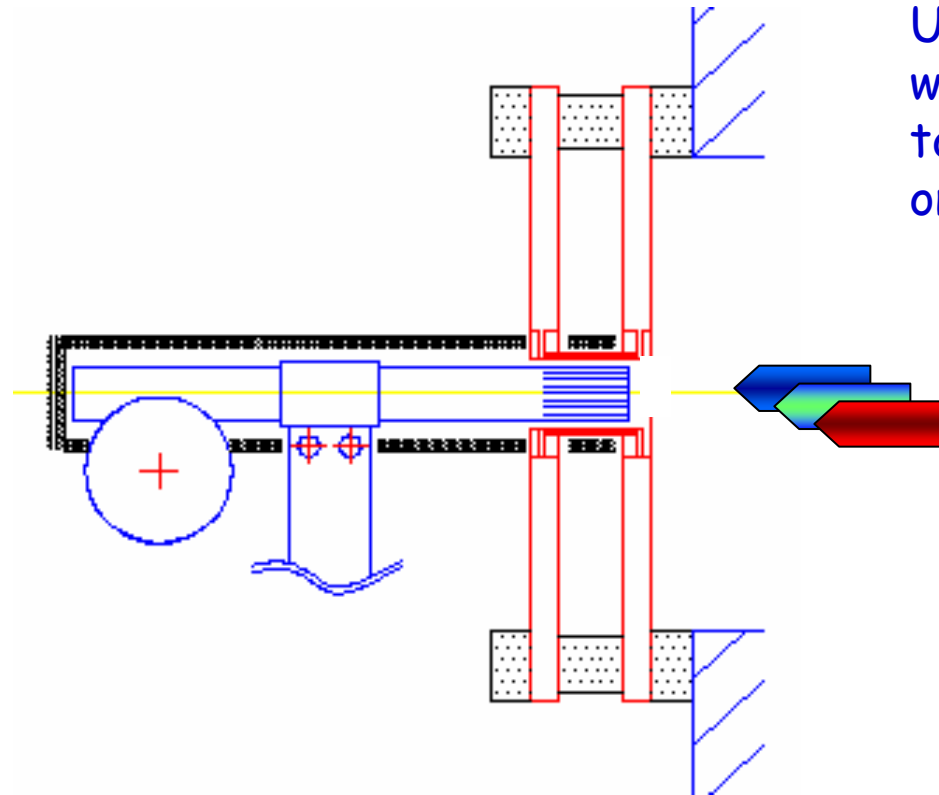

Using IRENA radial structure
with low voltage
to generate lots of radial electrons
only for confinement

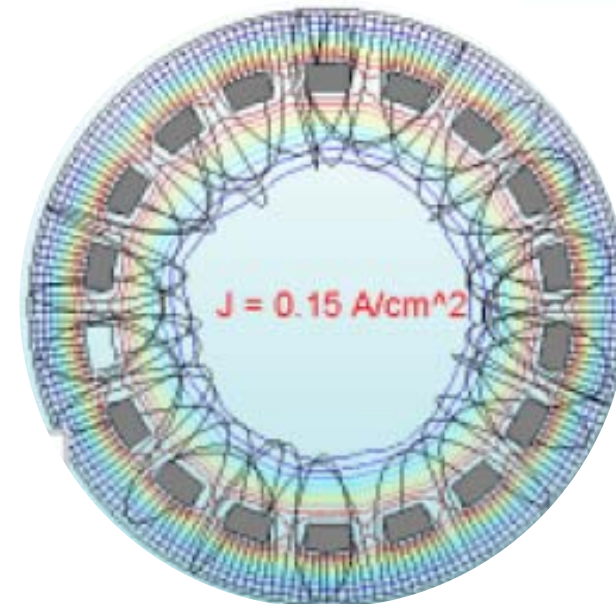

- Important to minimize target size as much as possible
Cf. also D. Ridika's poster
- To get beams from Multi-MW target, many aspects have to be considered: **specification on transfer tube, beam extraction, beam contamination etc.**
- Some possibilities for developing MW-station ion sources but requires important R&D works → need for support

Acknowledgment:

Many thanks to all collaborators, special thanks to R. Catherall, V. Fedoseev, A. Herrera-Martinez, Y. Kadi, J. Lettry, D. Ridikas, T. Stora, F. Wenander)