

# The prototype of high stiffness load cell for Rockwell hardness testing machine calibration according to ISO 6508-2:2015

M Pakkratoke<sup>1</sup> and T Sanponpute<sup>1</sup>

<sup>1</sup>National Institute of Metrology (Thailand), 3/4-5 Moo 3, Klong 5, Klong Luang, Pathumthani, Thailand 12120

**Abstract.** The penetrated depth of the Rockwell hardness testing machine is normally not more than 0.260 mm. Using commercial load cell cannot achieve the proposed force calibration according to ISO 6508-2[1]. For these reason, the high stiffness load cell (HSL) was fabricated. Its obvious advantage is deformation less than 0.020 mm at 150 kgf maximum load applied. The HSL prototype was designed in concept of direct compression and then confirmed with finite element analysis, FEA. The results showed that the maximum deformation was lower than 0.012 mm at capacity.

## 1. Introduction

The test force calibration is a part of indirect verification that requires from both international standards of ISO 6508 and ASTM E18[1]. In details, total test force and preliminary test force shall be calibrated under specific procedure especially on preliminary test force. It shall be calibrated in direction of increasing from preliminary test force to total test force and decreasing from total test force to preliminary test force. Furthermore, at least 3 positions of working movement, 300  $\mu\text{m}$  require for test force calibration. The calibration diagram was showed in figure 1.

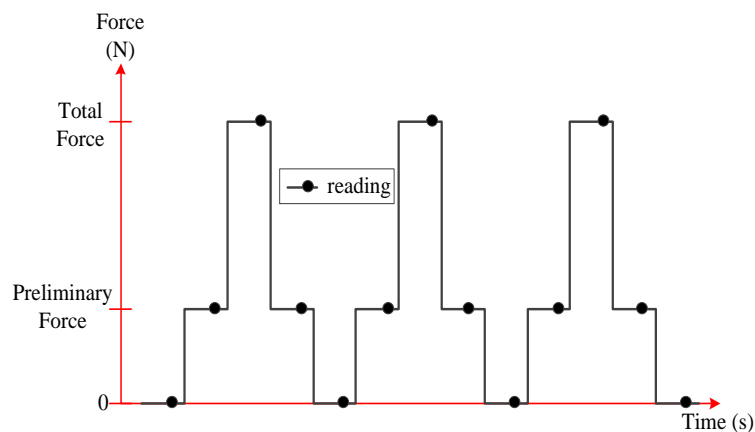

Figure 1. Test force calibration process diagram

In practical, the commercial load cell could not be used as force measurement standard properly as long as specific conditions of test force calibration as described above. From our experiment, a commercial load cell usually deforms more than 200  $\mu\text{m}$  at capacity. It could not be precisely applied on several calibrated positions over 200  $\mu\text{m}$  of increasing and decreasing directions as well.

As the reason described above, researcher have designed and constructed a high stiffness load cell which deform smaller than 20  $\mu\text{m}$  at maximum test force of Rockwell hardness test, 150 kgf. It shall be accurate within class 1 accordance with ISO 376 [2] as required by ISO 6508.

## 2. Conceptual design of the load cell

The prototype was designed in concept of direct compressional and tensional stress. To protect the overload, the capacity of load cell was appointed to be two times of maximum test force, 300 kgf. There were four parts of sensing body that bare the test force equally. Two sensing body parts were on upper side of pressure plate and received tension force. Another two sensing body parts were on lower side of pressure plate and received compression force. The overall conceptual design was illustrated in figure 2.

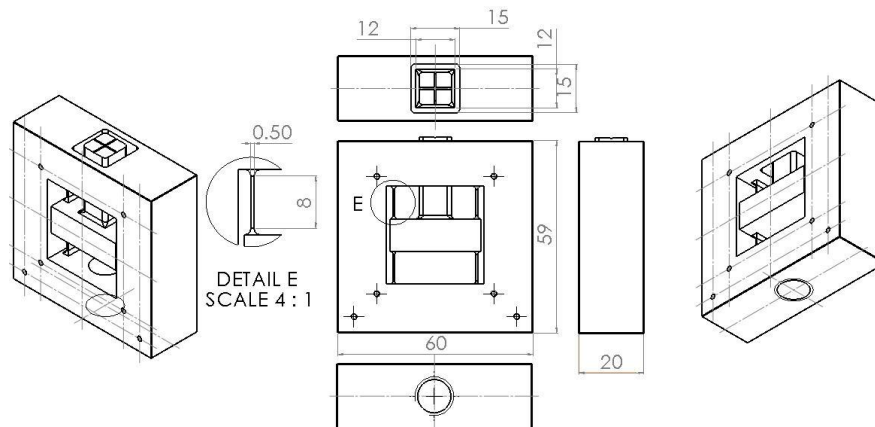

Figure 2. Conceptual design of the load cell

## 3. Experiment results

### 3.1. Verification result with finite element analysis (FEA)

This research verified the calculation results of amount of strain and deformation length with finite element analysis. It was illustrated as figure 4.

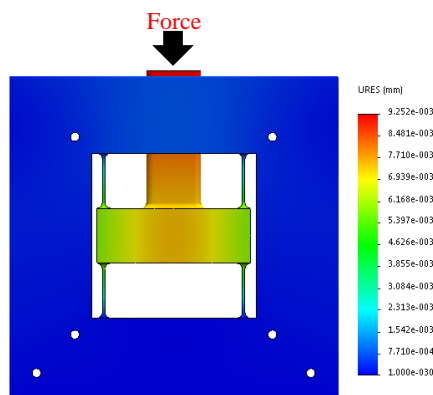

Figure 4. FEA deformation results of the load cell

The value of deformation length at maximum Rockwell hardness test force were  $5.0\ \mu\text{m}$  and  $9.25\ \mu\text{m}$  for calculation and FEA result, respectively which were different within  $4.25\ \mu\text{m}$ . It was affected by the weakness of pressure plate. The analysis results showed that it was deformed at  $3.02\ \mu\text{m}$ , however it achieved the aim of the research.

Another interesting quantity was strain; they were  $500 \times 10^{-6}\ \text{m/m}$  and  $458.2 \times 10^{-6}\ \text{m/m}$  for calculation and FEA result, respectively which agree within  $41.8 \times 10^{-6}\ \text{m/m}$ . The comparison result confirmed that the calculation and structural design met the aim of project and satisfaction.

### 3.2. Fabricated high stiffness load cell

The prototype was made after verification was successfully done. The fabricated high stiffness load cell was shown in figure 5.

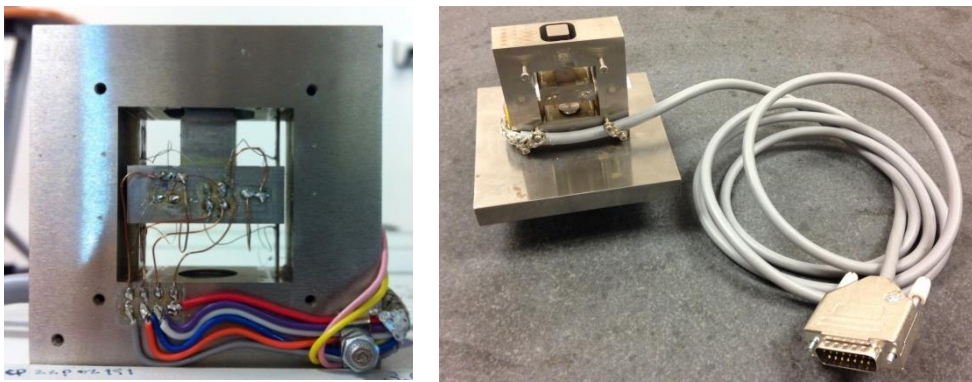

Figure 5. Fabricated high stiffness load cell

After machining load cell structure, measuring the real cross sectional area of sensing element was carried out since it directly affects the force capacity and deformation length. The results of dimensional measurement were  $0.495\ \text{mm}$  per area and  $7.03\ \text{mm}$  per long. Subsequently, they were deviate by  $0.02\ \text{mm}^2$  for cross sectional area and  $0.05\ \text{mm}$  for height of sensing body from their nominal values. The deviations obviously cause the stain and length of deformation change. Thus a re-analysing with dimensional measurement results were required in order to ensure that this machining structure could be acceptable. At forcing  $150\ \text{kgf}$ , re-analysing with actual dimensional results indicated that strain value and deformation length were  $510.3 \times 10^{-6}\ \text{m/m}$  and  $9.88\ \mu\text{m}$ , respectively. There was  $10.25 \times 10^{-6}\ \text{m/m}$  deviation for strain value. It confirmed that the design was acceptable. However,  $4.88\ \mu\text{m}$  deviation length was affected from pressure plate structure as described above.

### 3.3. Stiffness test versus FEA

Strain amplifier Model; DMP40 manufactured by Hottinger Baldwin Measurement Spedtris Pte. Ltd. (HBM) was connected to fabricate load cell. Previously calibration results showed their accuracy was within  $0.0025\%$ . The stiffness test of this research was carried out by using Rockwell primary hardness machine model SHT 31 as standard. It applied various test force and measured deformation length of load cell simultaneously. The test picture was shown in figure 6 (left).

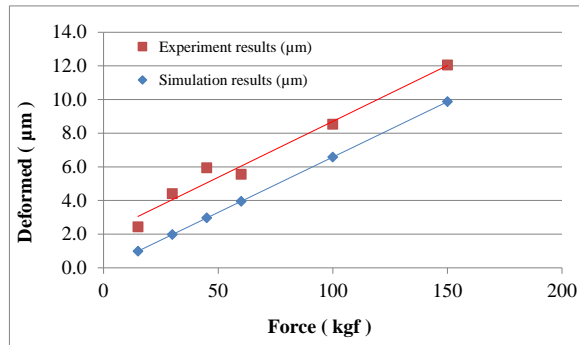
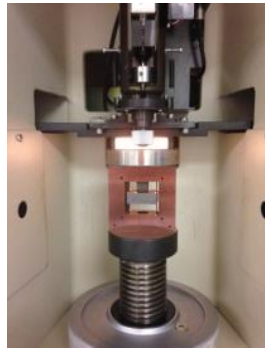

Figure 6. Stiffness test with primary hardness machine SHT-31 (left) and the Deformation results compared between FEA and stiffness test (right)

Measured deformation length at force applied from 15 kgf to 150 kgf was compared with FEA as illustrated in figure 6 (right). The comparative results indicated that both of them have the same slope of deformation length line. However experiment result noticeably showed an error 2 µm offset. Assumed that it was caused by additional deformation at contact points, as following between pressure plate and dummy indenter as well as between anvil and bottom of load cell. However the deformation length at maximum applied test force 150 kgf was less than 20 µm which it was satisfactory.

Moreover, the experimental result in mV/V was calculated back to the strain value in order that it could compare with calculation and FEA results. The strain values were  $542.57 \times 10^{-6}$  m/m,  $500 \times 10^{-6}$  m/m and  $510.25 \times 10^{-6}$  m/m for experimental result, design and FEA result respectively. Nevertheless, there were slightly deviated within 8 % for design and 6 % for FEA result from experiment result. It assumed that it was caused by Young's modulus of elasticity value which provide from not quite accurate technical data. However, an error was less than 10 % which could be acceptable.

#### 4. Conclusion

The 150 kgf high stiffness load cell was designed and constructed. The deformation length of load cell under forcing 150 kgf lower than 20 µm was an intention. The experiments obtained interesting results as following deformation length lower than 9.9 µm and strain value  $542.57 \times 10^{-6}$  m/m at forcing 150 kgf. Moreover, the results from design, FEA and experiments gave the consistent results within 5 µm and  $50 \times 10^{-6}$  m/m for displacement length and strain value, respectively. However, there were errors on deformation length measurement within 2 µm. They were caused by contact points in the measurement system. Regarding to more detail of FEA, the toughness of pressure plate of fabricated load cell was not good as expectation. It was deformed more than 3 µm at 150 kgf. The fabricated load cell could be deformed smaller than 10 µm if pressure plate would be designed for more strength. In the future, the load cell calibration and classification would be carried out. Consequently, the improvement on deformation length in several of micro meters would be an aim of the next research.

#### References

- [1] ISO 6508: 2015, "Metallic materials – Rockwell hardness test", 2015
- [2] ASTM E 18-14, "Standard test methods for Rockwell hardness of metallic materials, 2014
- [3] ISO 376: 2011, "Metallic materials -- Calibration of force-proving instruments used for the verification of uniaxial testing machine", 2011