



# Multilepton signatures from $tZq$ interactions in the SM and top-FCNC

On behalf of the CMS collaboration  
Isis Van Parijs – VUB - IIHE  
YSF TOP2016





# 3 lepton signatures from $tZq$ interactions in the SM and top-FCNC

On behalf of the CMS collaboration  
Isis Van Parijs – VUB - IIHE  
YSF TOP2016

8 TeV

# Searching for the three lepton final state in

- ① Top pair production
- ② Single top production

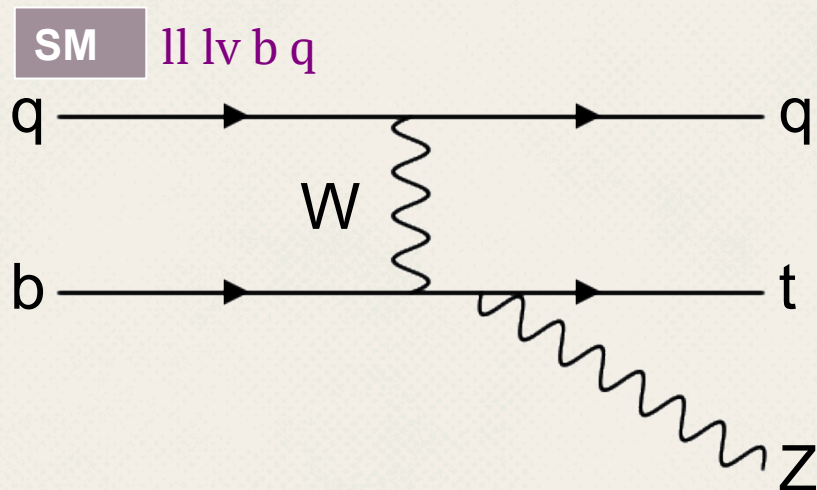
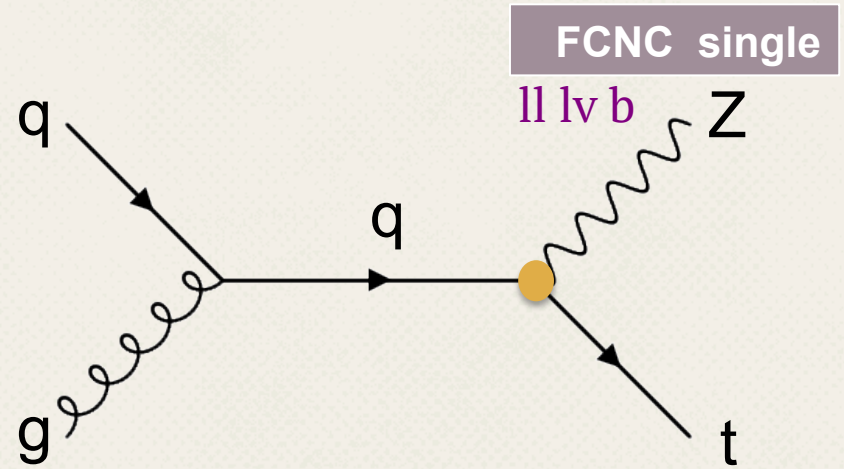
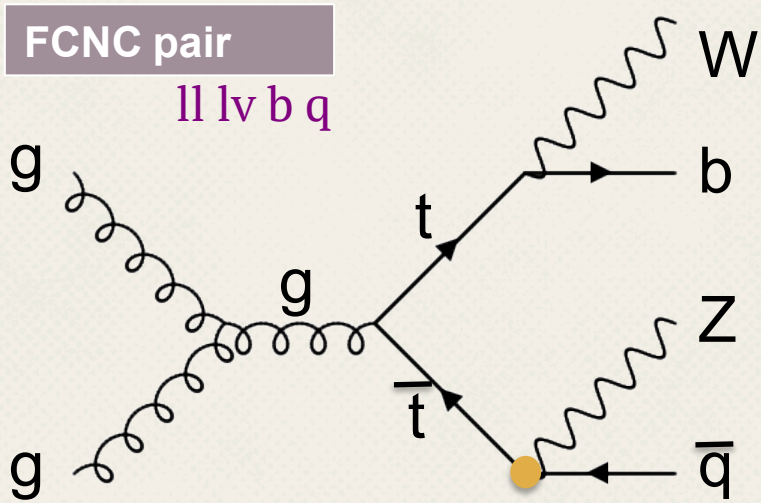

MORE  
INFO ↘

# FCNC $tZ(q)$ at 8TeV

## Signal Region

2 leptons compatible with Z

1 lepton from W

Top pair: At least 2 jets with at least 1 b-tagged (b-tag  $\epsilon=85\%$ , mis-ID  $\epsilon=10\%$ )

Single top: Exactly one jet, b-tagged

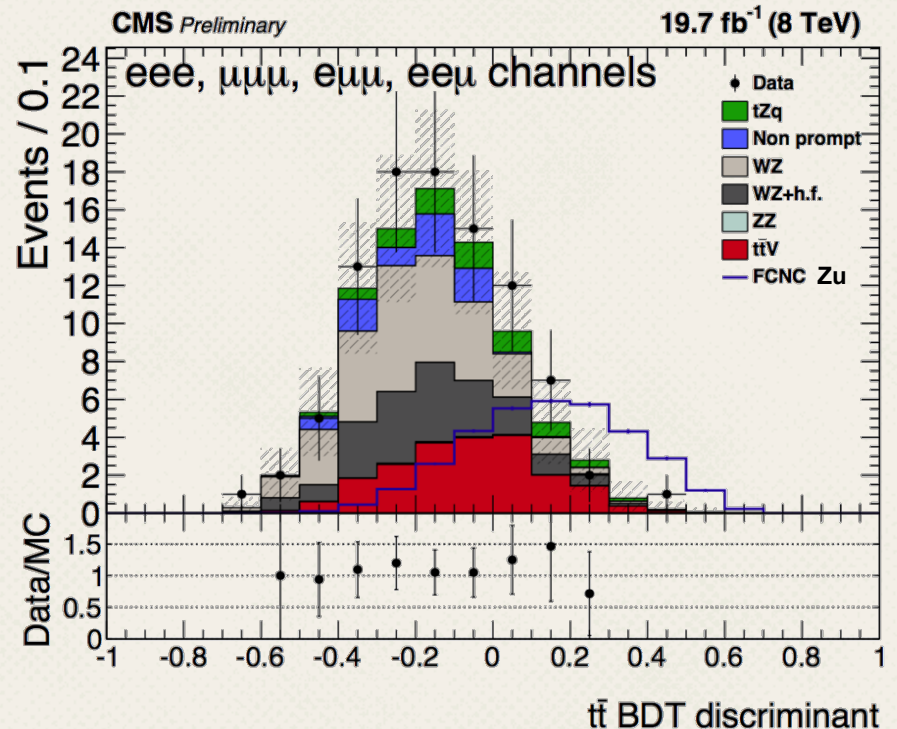
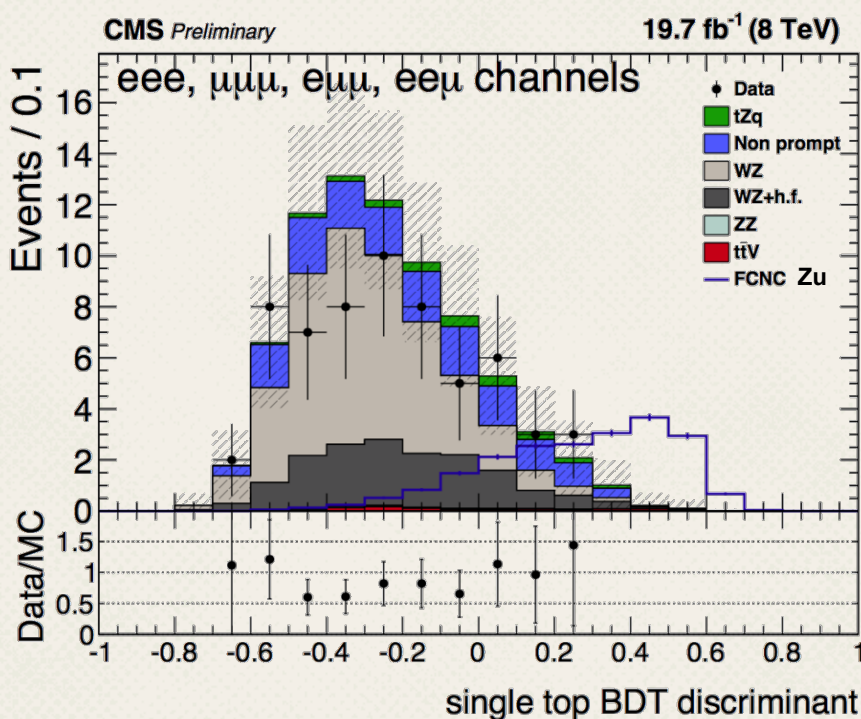

# FCNC tZ(q) at 8TeV

## Signal Region

2 leptons compatible with Z

1 lepton from W

Top pair: At least 2 jets with at least 1 b-tagged

Single top: Exactly one jet, b-tagged

Fake leptons are handled via data driven templates

Expected at low  $m_T(W)$

$$m_{T,W} \equiv \sqrt{2 \cdot E_{T,miss} \cdot p_{T,l} \left( \cos(\phi_{E_{T,miss}} - \phi_l) \right)}$$

## WZ Control region

2 leptons compatible with Z

1 lepton from W

1-2 jets with **NONE** b-tagged

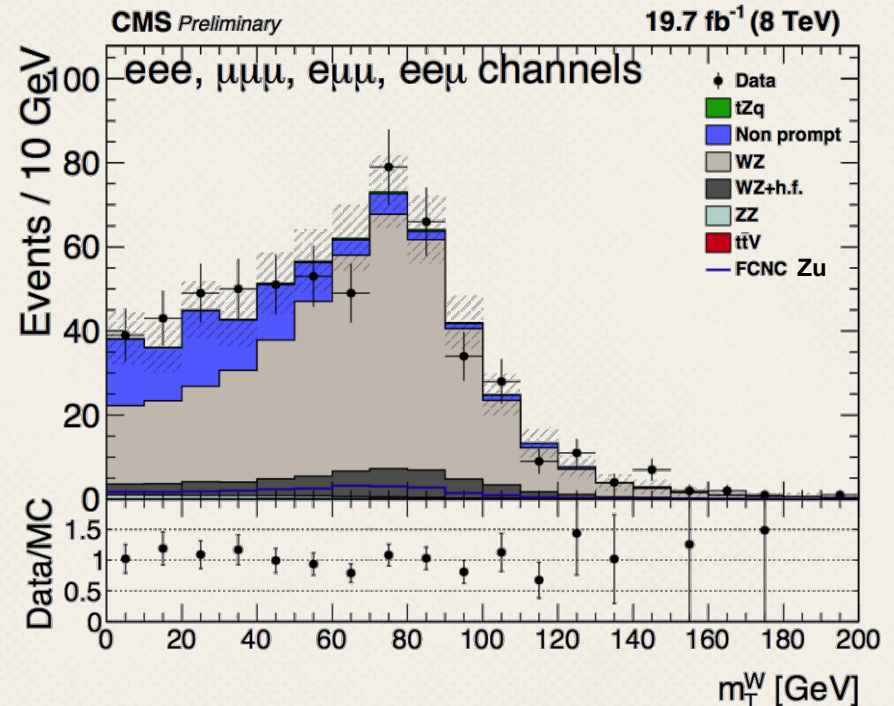

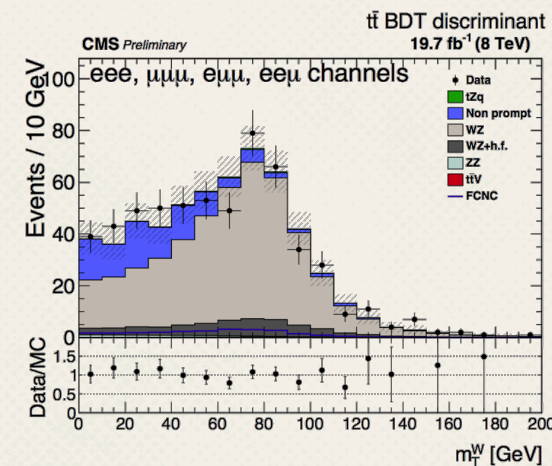
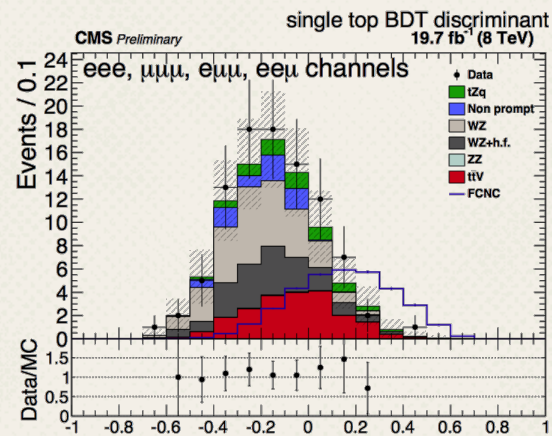
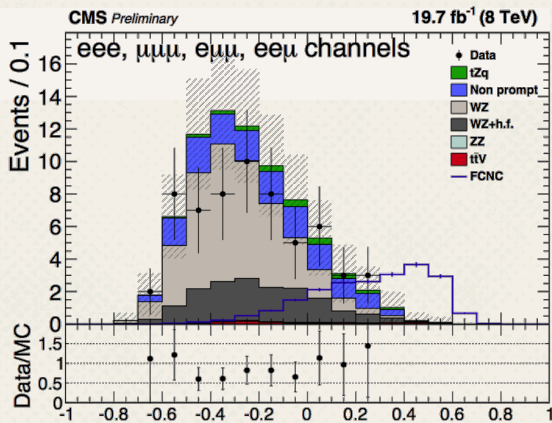

**SIMULTANEOUS  
FIT**

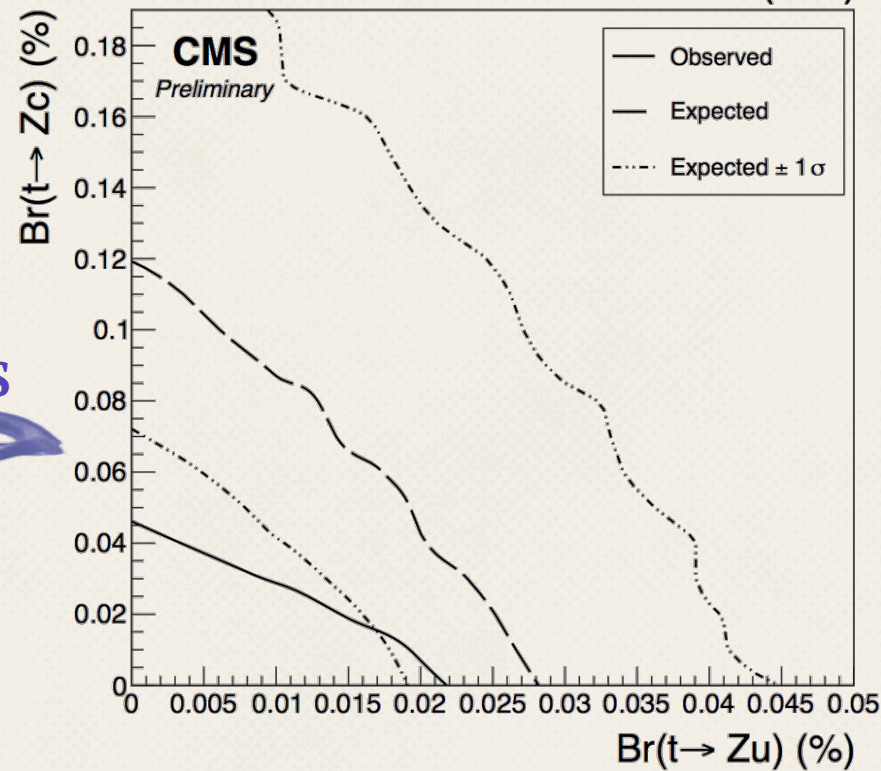

**Independent  
limit for tZu  
(tZc = 0)**

Exp. Branching ratio Zut  
(%) [1σ band]

0.027  
[0.018-0.42]

Observed BR Zut (%)

0.022

**Independent  
limit for tZc  
(tZu = 0)**

Exp. Branching ratio Zct  
(%) [1σ band]

0.118  
[0.071-0.222]

Observed BR Zct (%)

0.049

# Searching for the three lepton final state in

## The Standard Model

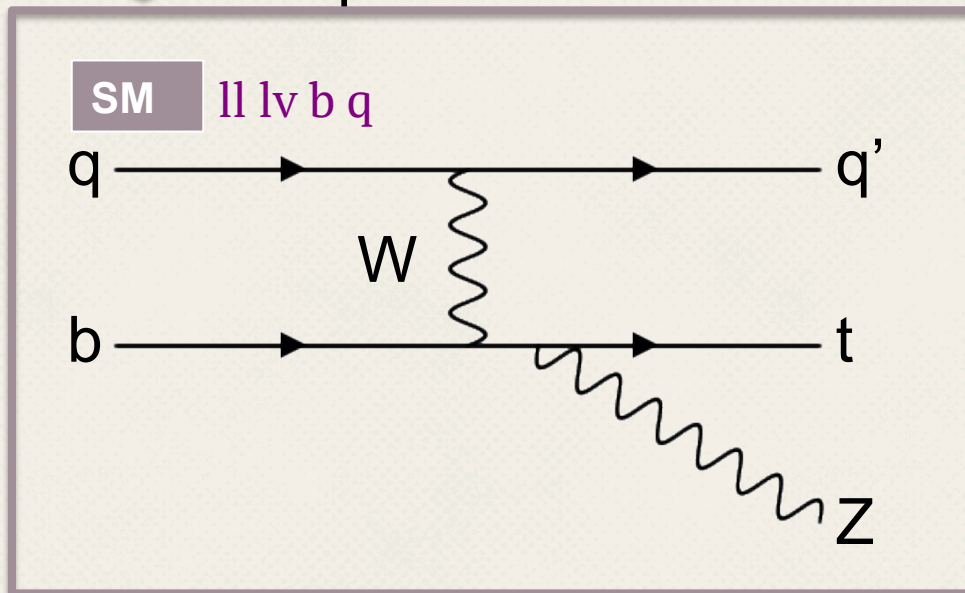
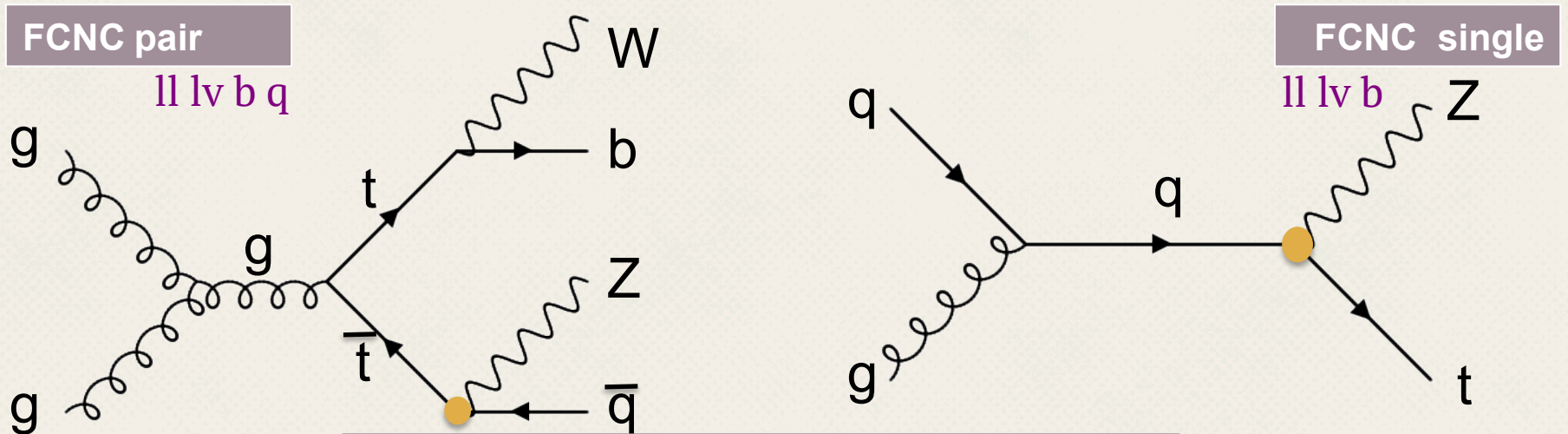

MORE  
INFO 

# SM tZq at 8TeV

Strategy is similar to FCNC, recoil jet tends to go forward

BDT  
Trained  
against  
ttZ + WZ

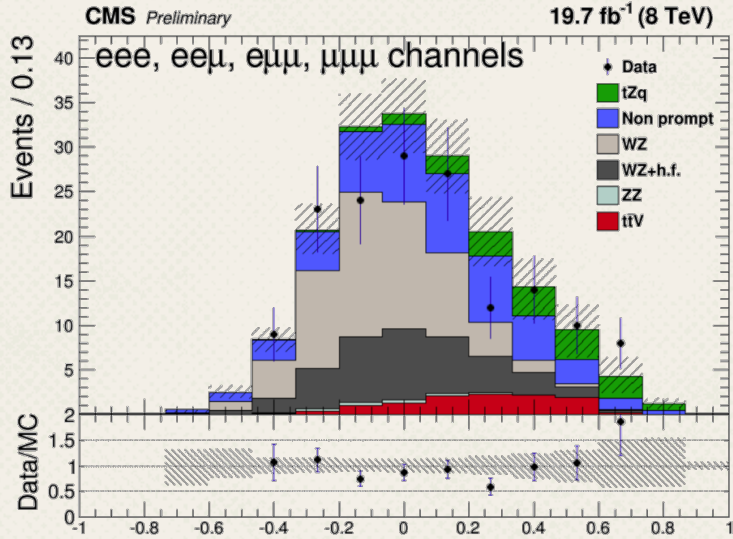

$|\eta| < 4.5$  instead of  $< 2.4$

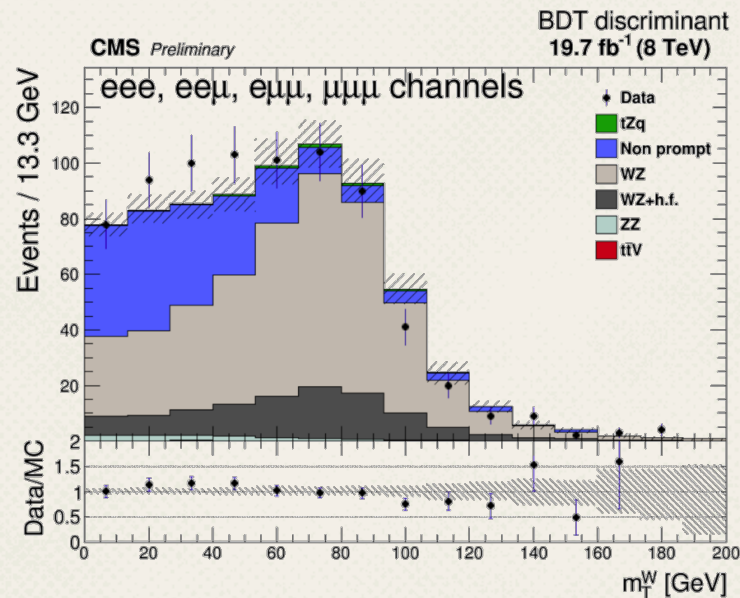

SIMULTANEOUS  
FIT

Signal strength [1σ band]	1.2 [0.6-1.9]
Cross section (fb)	$10^{+8.2}_{-7.0}$
Significance Observed (Expected)	2.4 (1.8) σ

SM prediction in 3l:  $\sigma = 8.2^{+0.06}_{-0.03}$  fb



On behalf of the CMS collaboration  
Isis Van Parijs – VUB - IIHE  
YSF TOP2016

