



Please contact the Cabinet Office for policy program details.

IMPACT Program Promotion Office, Cabinet Office

ImpACT Program Promotion Office, Cabinet Office
 (Science, Technology and Innovation Policy)
 1-6-1, Nagatacho, Chiyoda-ku, Tokyo 100-8914
 TEL +81-3-6257-1339 E-mail g.sentan.pro@cao.go.jp



Please contact JST for PM and program details.

Office for the Impulsing Paradigm Change through Disruptive Technologies Program

Office for the Impulsing Paradigm Change through Disruptive Technologies Program,
 Japan Science and Technology Agency
 K's Gobancho, 7, Gobancho, Chiyoda-ku, Tokyo 102-0076
 TEL +81-3-6380-9012 E-mail impact@jst.go.jp
 URL <http://www.jst.go.jp/impact/>

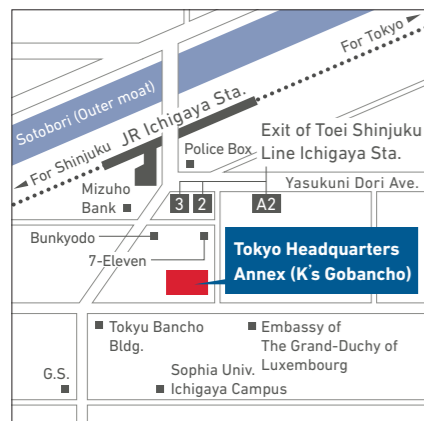

Impulsing
 PARadigm
 Change through disruptive
 Technologies
 Program

IMPACT

PM

Kohzo ITO / Realizing Ultra-Thin and Flexible Tough Polymers
 Keisuke GODA / Cell Search Engine – Turning Serendipity into Planned Happenstance –
 Yuji SANO / Ubiquitous Power Laser for Achieving a Safe, Secure and Longevity Society
 Masashi SAHASHI / Achieving Ultimate Green IT Devices with Long Usage Time without Charging
 Yoshiyuki SANKAI / Innovative Cybernic System for a “ZERO Intensive Nursing-care Society”
 Takane SUZUKI / Super High-Function Structural Proteins to Transform the Basic Materials Industry
 Satoshi TADOKORO / Tough Robotics Challenge (TRC)
 Reiko FUJITA / Reduction and Resource Recycling of High-level Radioactive Wastes through Nuclear Transmutation
 Reiko MIYATA / Ultra-high Speed Multiplexed Sensing System Beyond Evolution for the Detection of Extremely Small Quantities of Substances
 Takayuki YAGI / Innovative Visualization Technology to Lead to Creation of a New Growth Industry
 Yoshinori YAMAKAWA / Actualize Energetic Life by Creating Brain Information Linking Quantum Networks
 Yoshihisa YAMAMOTO / Advanced Information Society Infrastructure Linking Quantum Networks
 Seiko SHIRASAKA / Small Synthetic Aperture Radar Satellite System for On-Demand Observation
 Hiroyuki NOJI / Artificial Cell Reactor Technology for an Enriched and Secure Society and New Bioengineering
 Kanako HARADA / Bionic Humanoids Propelling New Industrial Revolution
 Hiroshi HARADA / An Ultra Big Data Platform for Reducing Social Risks

Impulsing PARadigm Change through Disruptive Technologies Program (ImPACT)

PMs Without Fear of Failure, Undertaking Challenges
to Achieve Social and Economic Reform

Science, technology and innovation is the driving force of economic revitalization. It is the source of the power to dramatically alter the direction of and cause a paradigm shift in society.

The 5th Science and Technology Basic Plan launched in fiscal 2016 outlines the strengthening of initiatives aimed at achieving disruptive innovation, driven by advancements in information and communication technology (ICT), and so forth. These advancements will lead the era of drastic change that brings about significant changes to our social and economic structures. The Plan also calls for enhanced efforts to promote open innovation and initiatives aimed at the realization of Society 5.0, a super-smart society that enriches the lives of the people by fusing cyberspace with the real world.

ImPACT (Impulsing PARadigm Change through Disruptive Technologies Program) is a program led by the Council for Science, Technology and Innovation. Founded in 2014, this program aims for the achievement of disruptive innovation. A distinctive characteristic of this program is the embracing of a high-risk, high impact philosophy. ImPACT focuses on difficult research without fear of failure. A second distinctive characteristic of ImPACT is that, to promote this kind of research and development, Program Managers (PMs) are entrusted with significant authority over matters such as planning, team organization, and budget allocation. Acting as executive producers, PMs invoke powerful leadership and management skills. They are responsible for the selection of researchers and R&D institutions, as well as overall R&D.

ImPACT represents the first steps towards the disruptive R&D that will cause social and economic reforms as outlined in the 5th Science and Technology Basic Plan. With four new PMs join the original twelve Program Managers, together they now embark on their respective missions to realize their research concepts and achieve outstanding results. I hope you will join me in looking forward to the results of their challenges.

April 2016
Minister of State for Science
and Technology Policy
Aiko Shimajiri

島原 志麻子



Background to
the establishm
of

ImPACT

Impulsing
PARadigm
Change through disruptive
Technologies
Program

Following the collapse of the bubble economy of the 1980s, Japan endured two decades of prolonged economic stagnation, also known as the Lost 20 Years. During this period, Japanese companies were unable to alter their conventional manufacturing strategies amidst great changes in the industrial structure and lifestyles, and this has resulted in an ongoing decline in the competitiveness of Japanese industry. At the same time, corporate leaders and the Japanese citizens themselves lost confidence, and it is said that Japan cannot any longer bear the risks required for growth.

In order to dispel these problems, it is essential that we build a new science and technology system in which universities and corporations can boldly tackle challenging research issues and open new areas of growth (innovation). ImPACT is a program through which the Council for Science, Technology and Innovation – the body that serves as the government's command center for innovation policy – will encourage high-risk, high-impact R&D, and aim to realize a sustainable and expandable innovation system.

Table of
contents

ImPACT program

- 04 • Program Managers – the leading players in ImPACT
- 05 • What ImPACT aims for

Introduction of each R&D program



- 06 • **Realizing Ultra-Thin and Flexible Tough Polymers**
Kohzo ITO



- 08 • **Cell Search Engine –Turning Serendipity into Planned Happenstance–**
Keisuke GODA



- 10 • **Ubiquitous Power Laser for Achieving a Safe, Secure and Longevity Society**
Yuji SANJO



- 12 • **Achieving Ultimate Green IT Devices with Long Usage Time without Charging**
Masashi SAHASHI



- 14 • **Innovative Cybernic System for a “ZERO Intensive Nursing-care Society”**
Yoshiyuki SANKAI



- 16 • **Super High-Function Structural Proteins to Transform the Basic Materials Industry**
Takane SUZUKI



- 18 • **Tough Robotics Challenge (TRC)**
Satoshi TADOKORO



- 20 • **Reduction and Resource Recycling of High-level Radioactive Wastes through Nuclear Transmutation**
Reiko FUJITA



- 22 • **Ultra-high Speed Multiplexed Sensing System Beyond Evolution for the Detection of Extremely Small Quantities of Substances**
Reiko MIYATA



- 24 • **Innovative Visualization Technology to Lead to Creation of a New Growth Industry**
Takayuki YAGI



- 26 • **Actualize Energetic Life by Creating Brain Information Industries**
Yoshinori YAMAKAWA



- 28 • **Advanced Information Society Infrastructure Linking Quantum Artificial Brains in Quantum Network**
Yoshihisa YAMAMOTO



- 30 • **Small Synthetic Aperture Radar Satellite System for On-Demand Observation**
Seiko SHIRASAKA



- 32 • **Artificial Cell Reactor Technology for an Enriched and Secure Society and New Bioengineering**
Hiroyuki NOJI



- 34 • **Bionic Humanoids Propelling New Industrial Revolution**
Kanako HARADA



- 36 • **An Ultra Big Data Platform for Reducing Social Risks**
Hiroshi HARADA

- 38 • The ImPACT mechanism
- 39 • Executive Members of CSTI

Visit the ImPACT website for the latest information,
including program overviews and achievements
<http://www.jst.go.jp/impact/en/index.html>

Program Managers

the leading players in ImPACT

Under the conventional R&D regime in which each institution uses the resources at its disposal, high-risk and high-impact initiatives are difficult. In order to encourage challenging R&D it is essential that we move away from our predisposition for insourcing, that we incorporate promising technologies from inside and outside the nation and achieve higher R&D targets, and that we link these to disruptive innovations. A successful transition to such R&D will require a scheme that fulfills the requirements below.

Concept Proposal

Describing a future that PM wish to realize in which what kind of concepts are realized.

Judging superior technologies

Evaluating and selecting the seeds of good technologies from among the vast range of R&D themes.

Collaboration and fusion that goes beyond field and organization

Binding together excellent personnel in various fields beyond the framework of organizations, and collaborating and fusing in a top-down manner.

ImPACT has adopted Program Managers (PMs) who will be producers in a different way from the usual researchers in order to serve the roles mentioned above. Armed with bold authority and budgets, the PM will set high targets for bringing about major changes in society and industry, will select a cast of researchers that provides optimum R&D capability, and will lead high-risk, high-impact R&D aimed at achieving disruptive innovation.



Disruptive innovation:

Innovation that is non-incremental and in which there is no continuity to the technology

What ImPACT aims for

Impulsing
PAradigm
Change through disruptive
Technologies
Program

The ultimate goal of ImPACT is to turn Japan into the country most favorable to innovation and a country brimming with the spirit of entrepreneurship and business start-ups. There are two targets that need to be met for the successful attainment of these goals.

Under ImPACT, the Program Managers will raise attractive concepts, if successful, that will bring about changes in the society and industry of the future. To achieve those concepts they will integrate the very best of R&D capabilities, pursue high-risk, high-impact R&D, and take on the challenge of creating disruptive innovation while wholly directing the R&D programs and displaying flexible management.

Creating disruptive innovation

Presenting an action model for innovation creation

To make Japan the country most favorable to innovation and a country brimming with the spirit of entrepreneurship and business start-ups, expanding the initiatives of ImPACT across the whole spectrum of the nation's businesses will be absolutely essential. By presenting to the business world the activities of the PMs who take on these challenges as an action model for innovation creation, we will seek to overturn the tendency for Japanese R&D to be introspective and cultivate an entrepreneurial atmosphere here in Japan.

Promotion of R&D programs

The R&D programs instituted under ImPACT are promoted according to the steps indicated to the right.

ImPACT themes

- Release from constraints on resources and innovation in "monozukuri (manufacturing)" capabilities
"Japan-style value creation for the new century"
- Realization of an ecologically sound society and innovative energy conservation that changes lifestyles
"Living in harmony with the world"
- Realization of a society of highly advanced functional that surpasses the information networked society
"Smart community that links people with society"
- Provide the world's most comfortable living environment in a society with a declining birthrate and aging population
"Realize healthy and comfortable lives for everybody"
- Control the impact and minimize the damage from hazards and natural disasters that are beyond human knowing
"Realize a resilience that is keenly felt by every individual Japanese"

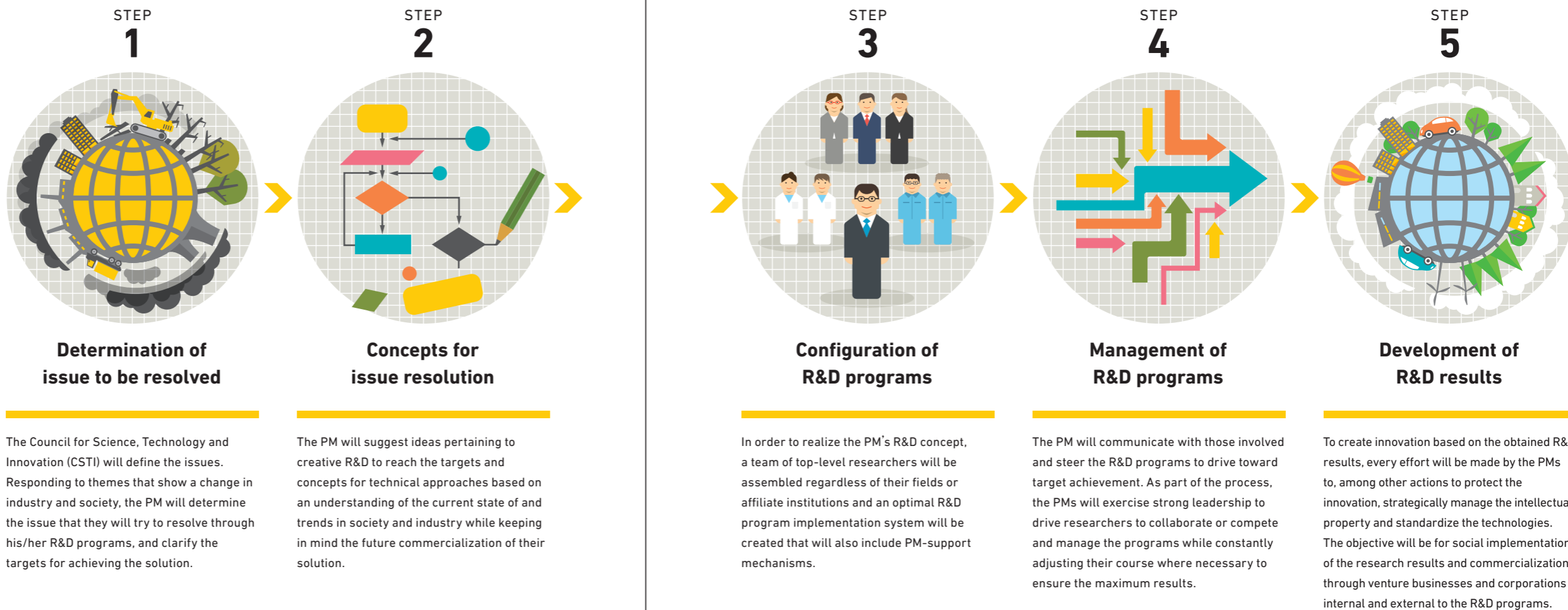

Determination of issue to be resolved

The Council for Science, Technology and Innovation (CSTI) will define the issues. Responding to themes that show a change in industry and society, the PM will determine the issue that they will try to resolve through his/her R&D programs, and clarify the targets for achieving the solution.

Concepts for issue resolution

The PM will suggest ideas pertaining to creative R&D to reach the targets and concepts for technical approaches based on an understanding of the current state of and trends in society and industry while keeping in mind the future commercialization of their solution.

Configuration of R&D programs

In order to realize the PM's R&D concept, a team of top-level researchers will be assembled regardless of their fields or affiliate institutions and an optimal R&D program implementation system will be created that will also include PM-support mechanisms.

Management of R&D programs

The PM will communicate with those involved and steer the R&D programs to drive toward target achievement. As part of the process, the PMs will exercise strong leadership to drive researchers to collaborate or compete and manage the programs while constantly adjusting their course where necessary to ensure the maximum results.

Development of R&D results

To create innovation based on the obtained R&D results, every effort will be made by the PMs to, among other actions to protect the innovation, strategically manage the intellectual property and standardize the technologies. The objective will be for social implementation of the research results and commercialization through venture businesses and corporations internal and external to the R&D programs.

Realizing Ultra-Thin and Flexible Tough Polymers

Analyzing the mechanism of a molecular structure that is flexible and yet difficult to break, and applying this mechanism to improve toughness of conventional low-cost polymers

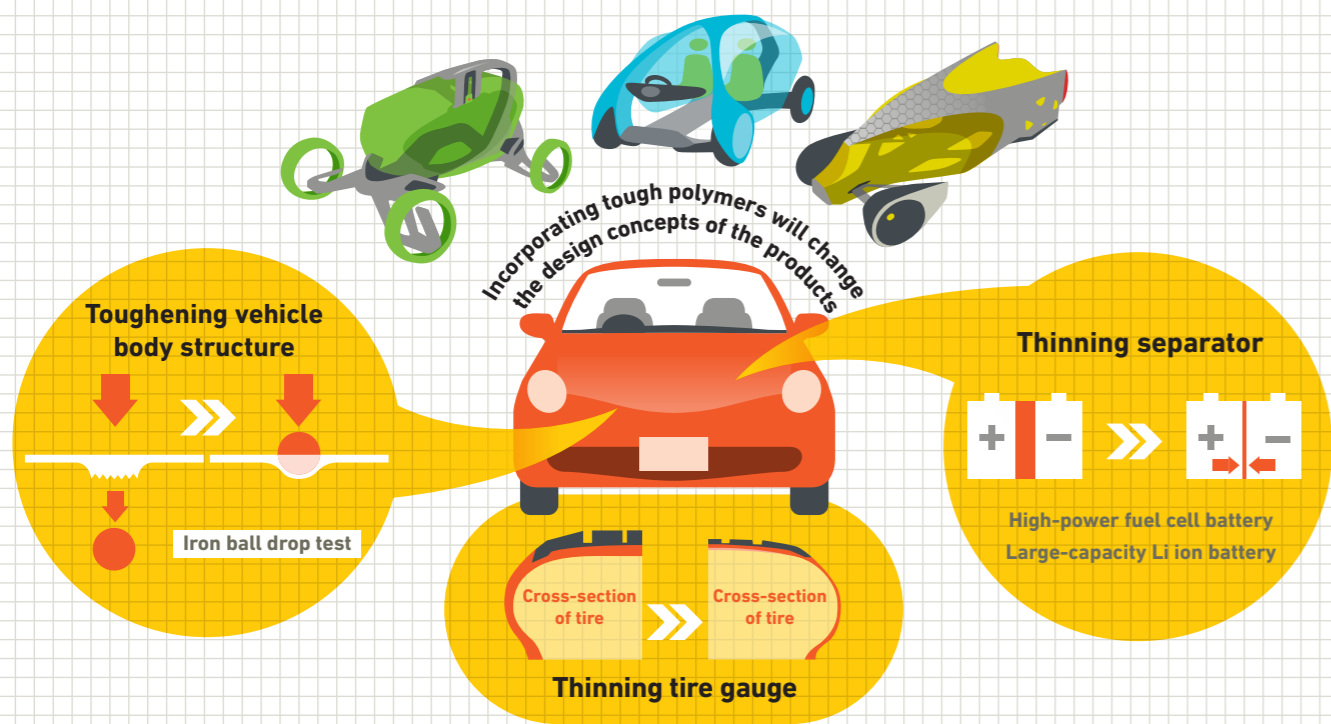

Polymers are so convenient that they are sometimes said to be the most versatile material ever developed by human beings. But the thinner they are, the more easily they tend to break, while if they are too hard, they become brittle. The goal of this program is to develop tough, flexible polymers that achieve both thinness and toughness exceeding conventional limits. Polymers that combine toughness, flexibility and self-restoring capability (the material recovers the damage in response to heat or light) will produce dramatic breakthroughs in automobile components and transport equipment. They will also have a widespread ripple effect throughout all industries that use polymeric materials, and in the future will meet society's needs for safety, security and low environmental impact.

Message

The objective of my program is to realize tough polymers that are thin but hard to break even when subjected to impact. To this end, I manage to realize the best synergies of research potentials from both academia and industries, taking advantage of Japan's state-of-the-art research facilities. This program will contribute to produce new commercial polymer technologies that break the existing limitations in current polymer technologies. The program will have a big impact in realizing a more energy-sufficient, safer, and sustainable society in the near future.



Program Manager

P M

Kohzo ITO
伊藤 耕三

- 1986 Doctor of Engineering, The University of Tokyo
- 1986 - 1991 Researcher & Senior Researcher, Research Institute for Polymers and Textiles
- 1999 Invented slide-ring materials (SRM) with freely movable cross-links
- 2003 ~ Professor, The University of Tokyo
- 2005 - 2014 Founder and Director, Advanced Softmaterials, Inc.
- 2014 ~ ImPACT Program Manager

Clarifying the molecular mechanism of failure using SPring-8, K computer, and other large-scale facilities

It would take too much time to use the conventional trial-and-error development approach to create a difficult-to-break "tough polymers" that have a variety of functions for industrial uses. Moreover, there is no available theory to link the molecular level design that produces toughness with macro-level fracture mechanics, making it difficult to create tough polymers that meet various actual needs. Top-level experimental and theoretical research groups in Japan are joining forces in order to resolve these problems.

In order to create a new theory of fracture behavior, our program combines theoretical and experimental approaches. The experimental approach includes setting up a high-speed destructive test system at SPring-8, the world-class synchrotron radiation facility, in order to understand

fracture phenomena through time-space hierarchical in-situ observations. Also to be developed is a series of equipment for measuring localized stress distributions and fracture energy, providing data that can clarify the molecular mechanism of fracture. We employ the K computer to conduct large-scale atom-by-atom simulations for coupling theoretical considerations and experimental data.

These achievements will be provided as practical knowledge to material manufacturers in Japan that have a variety of outstanding production technologies. Each company will compare the fracture behavior of existing materials and newly developed ones in order to establish guidelines for molecular and materials designs that are compatible with their own products.

Furthermore, in order to develop thin, tough polymers based on these guidelines, we develop a new synthesis scheme for the molecular bonding and new processes for high-order structural control. Evaluation tests in an actual environment will be performed for the tough polymers (by incorporating them as on-board components in automobiles and the like) in order to confirm the industrial applicability of the various types of tough polymers from the perspective of a vehicle manufacturer. Life cycle assessments will also be performed to verify the socio-economic value of the materials.

These schemes will bring dramatic evolution in the development process of commercially required materials, providing a unique and innovative material development methodology.

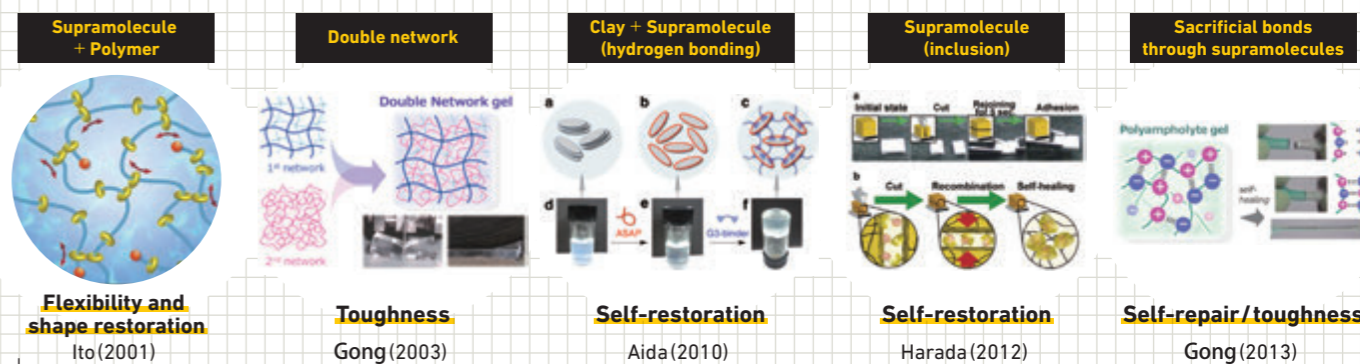

Hardness ≠ toughness = difficult to break

Flexible toughness

Molecular and material designs to achieve tough polymers

In recent years, new molecular structures with elongation, toughness, self-restoration and other properties that would have been unthinkable with conventional polymers have been discovered (particularly in Japan) and have received worldwide notice. However, it is afraid that new molecules will generally be too expensive to be incorporated widely into usual polymeric materials, and that therefore little progress will be made in terms of commercial availability. The goal of this program is to clarify the molecular mechanism through which these new molecular structures can provide toughness to polymer materials, and to introduce the new molecular concepts for providing toughness to usual inexpensive polymer materials used by companies, in order to achieve commercially available tough polymers rapidly and strategically.

R&D Team Organization / Management and Research Promotion / Future Prospects

Flexible organization focusing on the development of elemental technologies for highly safe, energy-efficient automobiles and on the achievement of prototypes

A fundamental cross-sectional research and development team will be established in order to treat a common feature of polymer toughness while achieving the requirements for individual companies using the aforementioned technical approach. There are five major challenges:

- Clarification of the molecular mechanism of polymer fracture
- Establishment of molecular and material design guidelines
- Development of a new method for controlling the molecular structure
- Realization of ultra-thin tough polymers
- Evaluation and verification

Academic institutions and companies will work tightly with one another to form a flexible organization that can respond to needs in order to work toward solutions.

Specifically, the organization will be made up of the projects shown at right. For projects ①-⑤,

- establishment of the molecular and material design guidelines is needed to create various tough materials. This will enable both ultra-thinness and toughness to be achieved.
- ① **Fuel cell electrolyte membranes:** ultra-thinning electrolyte membranes (gel membranes) for fuel cells
 - ② **Li ion battery separator:** ultra-thinning lithium ion battery separator (porous medium)
 - ③ **Vehicle body structural resins:** toughening structural resins for vehicle bodies (crystalline resins)
 - ④ **Tires:** achieving thin-gauge tires (amorphous elastomer)
 - ⑤ **Transparent resins:** toughening transparent resins (amorphous resins)
 - ⑥ **Systematization and evaluation:** systematizing and evaluating the new tough polymers developed in projects ① - ⑤ from the perspective of an automobile manufacturer,

assessing their applicability to industry.

⑦ **Fundamentally cross-sectional research issues:** resolving fundamentally cross-sectional problems common to all projects such as "Clarification of the molecular mechanism of polymer fracture" "Development of a new method for controlling the molecular structure" "Verification of social value" and so on.

The achievements of this research will produce breakthroughs in the automotive industry through the achievement of safer, more energy-efficient vehicles and so on. They will also be applicable to a wide variety of polymers that are used in state-of-the-art fields, such as those in transport devices, electronic devices, medical equipment and so on. The ripple effects will also achieve a major reduction in CO₂ emissions with a safe, secure and low environmental impact society that is based on long-term reliability in polymeric materials.

Cell Search Engine

—Turning Serendipity into Planned Happenstance—

The cell search engine is based on an interdisciplinary integration of methods in **photonics, electronics, computer science, analytical chemistry, and molecular biology** for diverse green and biomedical applications.

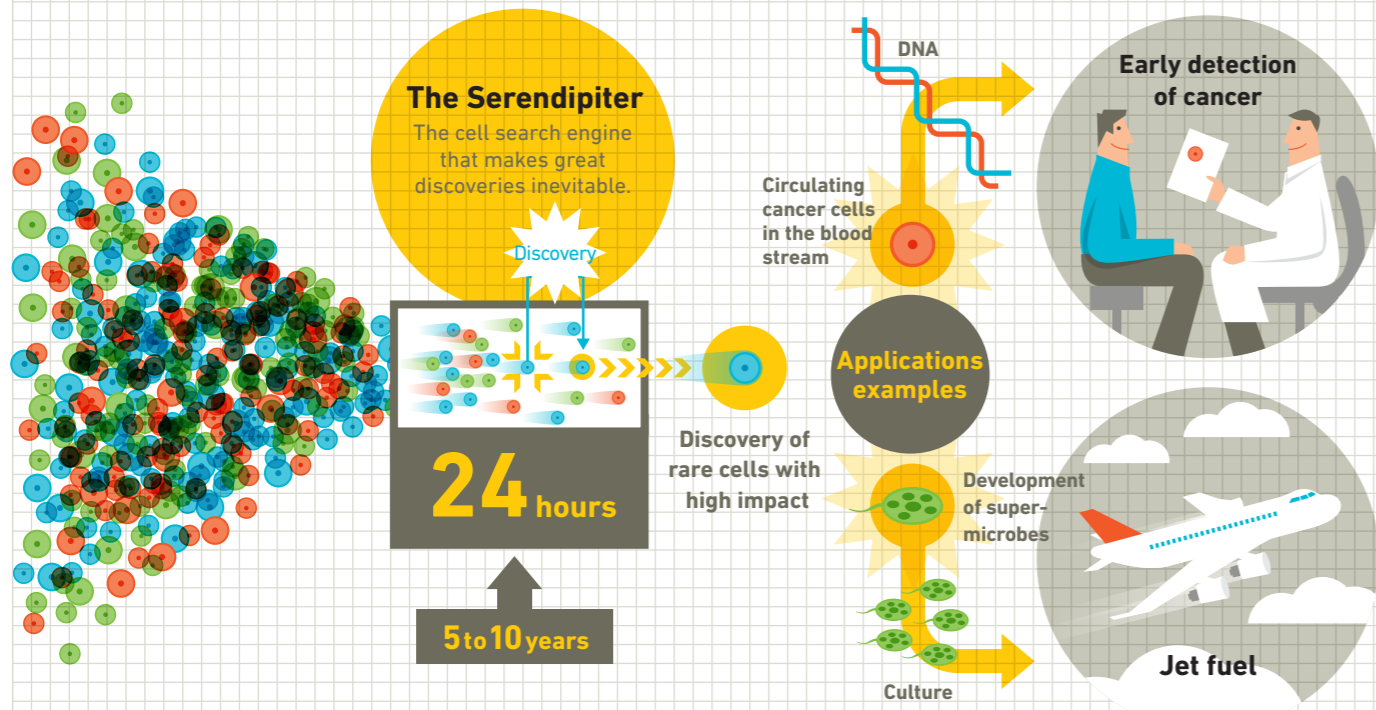

The objective of this program is to develop an innovative technology for systematically achieving serendipity — the Serendipiter — by integrating advanced methods and techniques in diverse fields including photonics, microfluidics, molecular cell biology, bioinformatics, and genetics. The Serendipiter is a miraculous cell search engine that discovers and analyzes rare, but valuable cells from a large heterogeneous population of cells quickly and accurately. It holds great promise for replacing time-consuming trial-and-error-based procedures and causing serendipity in the field of life science.

Message

Japan used to be a country with advanced technologies that cannot easily be copied by other countries, but, through the commodification of such technologies, Japan's high-tech industry has been taken over by developing countries where labor costs are low. Today, Japan is only a few years ahead of those countries even in the fields where Japanese manufacturing is still strong. What the country needs right now is not to continue with conventional technology developments that only generate incremental achievements, but a paradigm shift in the industrial foundation that will foster the development of frequent breakthroughs. As with the invention of the Internet or the discovery of DNA, this industrial foundation will bring us a new culture of open innovation in which people in both academic and industrial sectors can come up with and demonstrate innovative ideas, leading to new markets and entrepreneurial fields beyond our imagination.



Program Manager

P M
Keisuke GODA
 合田 圭介

- 2001 B.A., physics, University of California, Berkeley
- 2007 Ph.D., physics, Massachusetts Institute of Technology
- 2012 ~ Professor of Chemistry, University of Tokyo
- 2014 ~ ImPACT Program Manager

Making accidental discoveries systematic! Establishing a platform that will regularly produce great discoveries

Science builds on reproducibility – one of the most fundamental principles of the scientific method under which an experimental test must be reproduced or replicated in order to verify whether a proposed hypothesis is correct. However, this principle is based on the assumption that the tested system be sufficiently simple so that experimental results can easily be reproduced. As the system becomes more and more complex (e.g., large molecules, biological cells, microbes), it is increasingly difficult to achieve reproducibility and the chance of uncovering hidden laws of nature hence decreases, rendering the act of making discoveries more and more serendipitous or accidental. In this program, we focus on the development of radically novel technologies that address this fundamental problem in science.

The Serendipiter to be developed is expected to systematically find and analyze the traits of cells which are irretrievably buried in statistical data and hence efficiently discovery and enhance useful cellular capabilities and unknown biological phenomena. The Serendipiter is a cell search engine that can perform high-throughput screening of cells in a large heterogeneous population with single-cell resolution and extremely high precision, turning serendipity into planned happenstance. We aim to achieve this by integrating advanced methods and techniques in diverse fields including photonics, microfluidics, molecular cell biology, bioinformatics, and genetics.

The strategy of this program is to develop the basic technology, to demonstrate its utility in the production of high-efficiency algae-based biofuel and low-cost personalized medicine, and

to simultaneously build a startup, commercialize the technology, and bring it to the market. Specifically, in the biofuel application, we aim to use the Serendipiter for the identification of genetically engineered super-euglena cells with the ability to photosynthesize with high efficiency, tolerate against harsh environmental changes, and convert sugar into lipid with high efficiency. Furthermore, in the medical application, we aim to use it for the high-precision identification and sorting of rare diseased cells, immune cells, and stem cells in blood that can be exploited for low-cost personalized medicine. Other applications of the Serendipiter include water purification, functional food, and bacterial detoxication.

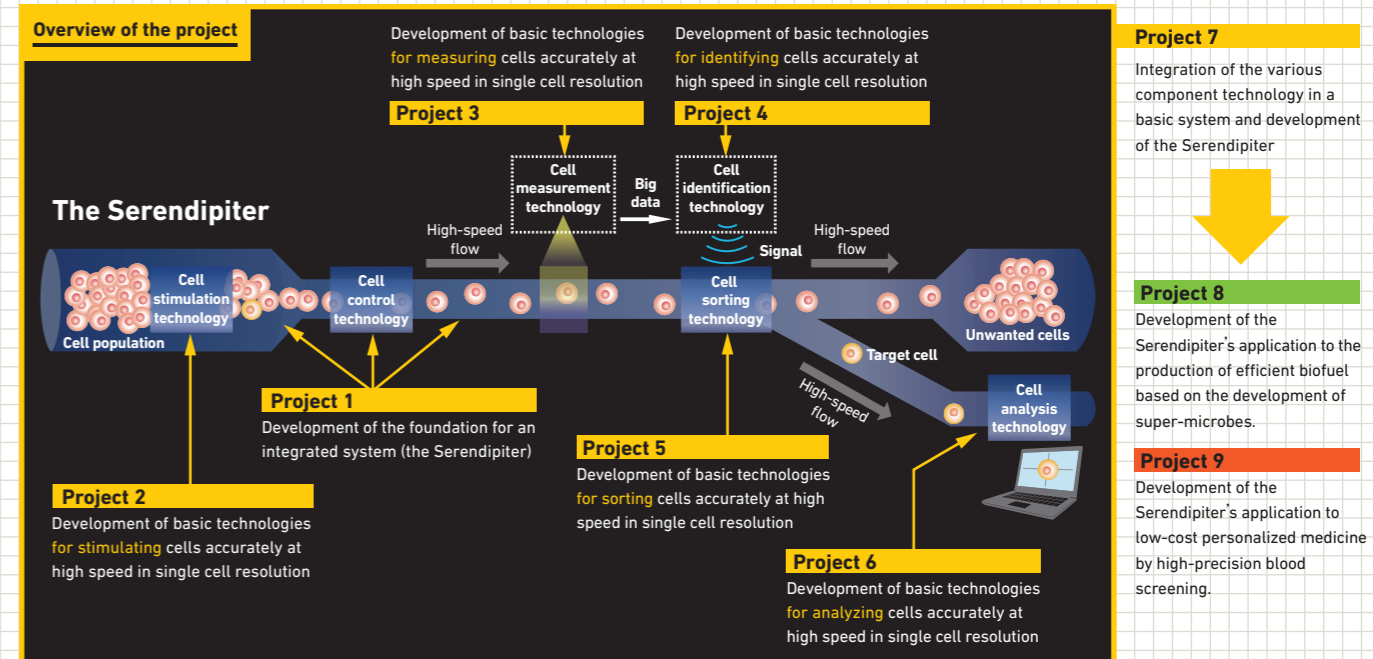

The team consists mainly of young researchers under 45 years old

In analogy with the development of detectors in particle physics experiments, we aim to build the Serendipiter by integrating several key subsystems into a single instrument. In the development of subsystems, several different approaches are exploited in parallel without relying on specific methods or techniques in order to minimize the risk of the overall program.

The development of the Serendipiter comprises the following nine projects that are conducted by young researchers under the age of 45 with some exceptions.

- ① **Platform development:** Development of a platform system as a foundation for the integrated system (the Serendipiter)
- ② - ⑥ **Subsystem development:** Development of subsystems required for five important processes (stimulation, measurement, identification, sorting, and analysis).
- ⑦ **Integration of the subsystems:** Development of the integrated system (the Serendipiter) by combining all the subsystems into a single unit.
- ⑧ **Evaluation A:** Development of the Serendipiter's application to the production of efficient biofuel based on the development of super-microbes.
- ⑨ **Evaluation B:** Development of the Serendipiter's application to low-cost personalized medicine by high-precision blood screening.

With the establishment of the Serendipiter, we anticipate to bring a paradigm shift to the bioscience-related industry and medical field by significantly reducing the time constraint. In addition, we aim to establish a startup at an early stage to facilitate the acquisition and transfer of intellectual properties and hence bring the technology to real-world situations as early as possible so that everyone will have access to it and benefit from it.

Ubiquitous Power Laser for Achieving a Safe, Secure and Longevity Society

Achieve ultra compact X-ray free electron lasers using laser plasma acceleration that can be used anywhere, at any time

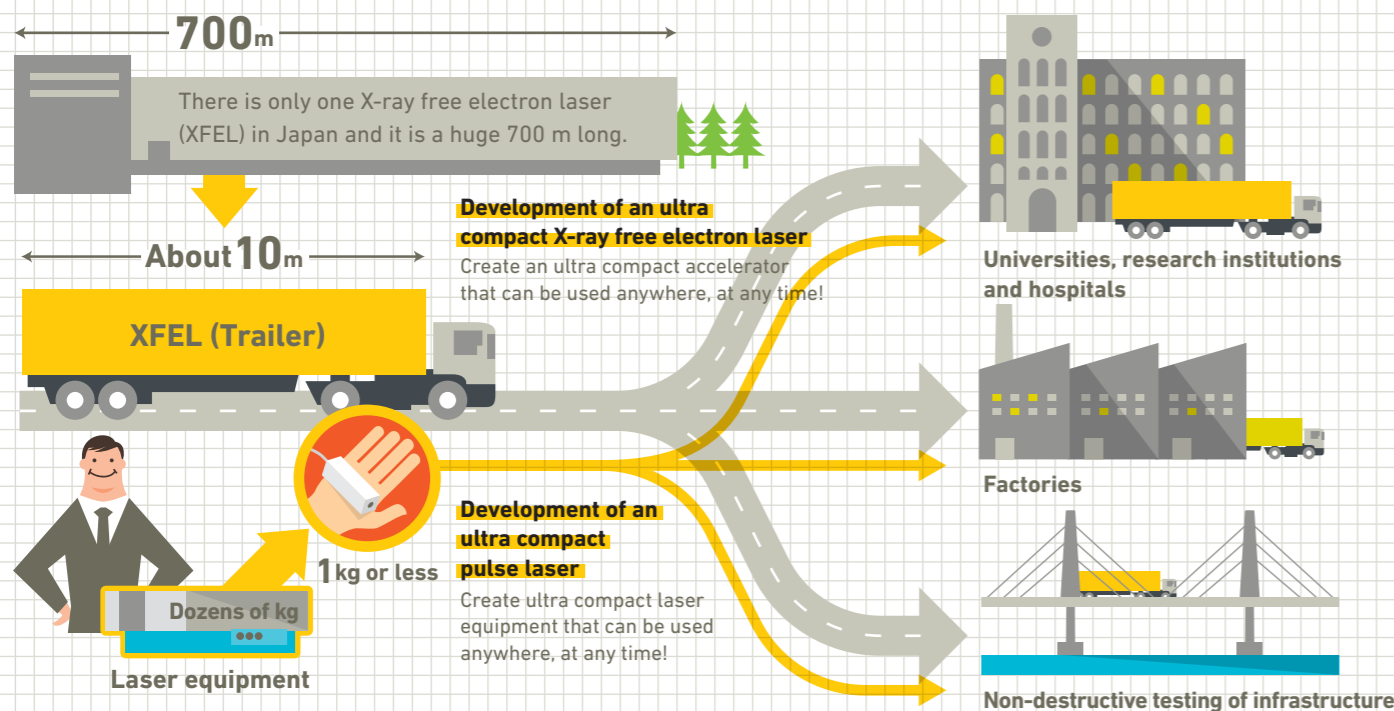

X-ray free electron lasers (XFEL), which combine the characteristics of X-rays and lasers, provide "miraculous light" that can analyze materials at the atomic level. However, they require large accelerators on the kilometer scale, and at present there is only one up-to-date testing facility in Japan that has achieved this (SACLA). It's not something that anyone can use easily. Therefore this program will achieve an ultra compact XFEL by combining laser, plasma and accelerator technology in a laser plasma accelerator. If the XFEL can be used anywhere at any time as a result, it will come to be used in a wide range of fields such as industry and medical care, making it possible to achieve a society where people enjoy longevity with safety and security.

Message

Lasers, which were invented in the twentieth century, have been put to a wide variety of applications from research and development to industry, bringing many achievements. However, they are still big devices which are hard to handle, preventing them from being used in wider fields. Therefore, by achieving miniaturization technology that can reduce high power lasers to palm size, and establishing technology for miniaturizing X-ray free electron lasers (XFEL), known as the ultimate light, of which there are only two in the world, we will create new technologies and new industries that enable people to lead safe, secure and pleasant lifestyles.



Program Manager

PM
Yuji SANO
佐野 雄二

- 1977 Received Master's degree from the Graduate School of Science and Engineering, Tokyo Tech (majoring in nuclear engineering)
- 1977 Joined Toshiba Corporation
- 2006 ~ 2008 Senior Fellow, Power and Industrial Systems R&D Center
Received the Commendation for Science and Technology by the Minister of Education, Culture, Sports, Science and Technology
- 2008-2014 Program Officer for the "Photon Frontier Network" of the Ministry of Education, Culture, Sports, Science and Technology (MEXT).
- 2014 ~ ImPACT Program Manager

Bring the use of an XFEL* (a National Critical Technology) close at hand! Starting a grand project

X-ray free electron lasers don't use the phenomenon where electrons in substances emit light. Instead, electrons are controlled and directed by a high energy accelerator from which X-rays are generated. It's called X-ray free electron laser (XFEL) because it makes X-ray lasers using free electrons stripped from atoms.

The equipment that makes this XFEL comprises an electron gun that forms the electron source, an electron accelerating tube, and a device called an undulator formed of many magnets that makes the electrons wiggle. The X-ray that is generated in this way is then self-amplified to be X-ray laser. This program will modularize the electron accelerator as a plasma device based on new technology for

electron acceleration using laser plasma which Japan currently leads, achieving an ultra compact XFEL device.

With this new technology, an intensive plasma wave is generated using a pulse laser, creating a strong electric field which accelerates the electrons. The stronger the electric field, the shorter the distance required to accelerate the electrons. We will reduce the acceleration length to 1/1,000 of the current standard. The electron beam emitted from the plasma will be converted into an X-ray laser by an ultra compact undulator. Ultimately achieving a table-top sized ultra compact XFEL device with the development of these technologies is a grand idea that will bring about a paradigm shift in Japanese industry and public life.

The issues that must be overcome to attain our target are the achievement of stable, high-energy electron acceleration using plasma density control, the development of an ultra compact undulator, as well as the development of high precision beam diagnosis and control technology and a high performance plasma power supply. In parallel with these developments, we will develop proprietary technologies such as a high-efficiency oscillator using a microchip laser and ceramic laser medium, and attempt to achieve an ultra compact high output pulse laser.

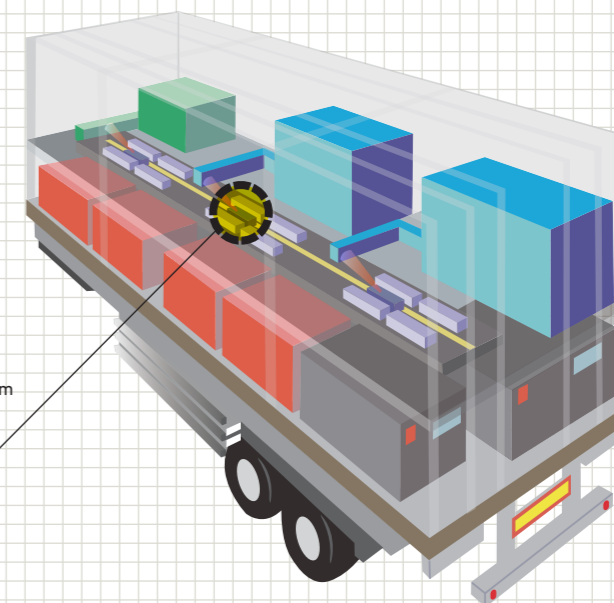
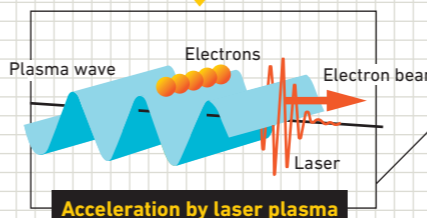

Electrons traveling at close to the speed of light that are required to generate an XFEL are accelerated using an electric field. If the electric field is too strong, the device will break, so the electrons are accelerated over a long distance (several hundred meters to several kilometers). If you generate plasma with an intense laser pulse, you can make an electric field that is stronger by over 1,000 times. For this reason, it is possible to accelerate electrons over a short distance (several dozen centimeters to several meters), achieving ultra compact XFELs.

Assemble the technologies for the laser, plasma and accelerator, and establish a reciprocally complementary co-creation organization

XFEL technology is the focus of worldwide attention. Following America and Japan, the EU, Switzerland, Korea and other countries have started building them, and competition is heating up. While maintaining Japan's advantage, it's important to take the initiative towards achieving commercial application of the technology through the miniaturization. Therefore we will establish a platform uniting laser, plasma and accelerator technologies in one place for realizing an ultra compact XFEL device. Based around this platform, we will establish a co-creation organization to enable the experts in each field to undertake mutual research complementarily to accelerate the development.

The project comprises the following three projects.

- ① **Laser acceleration & XFEL demonstration:** Develop a laser acceleration component technology, achieving stable electron acceleration and modularizing a plasma device; a micro undulator that generates an X-ray beam at less than 1/10 of the length of a conventional undulator; a laser acceleration integrated platform (center) that accelerates electrons to over 1 GeV with multistage arrangement of modules, emitting a 1 keV X-ray beam when combined with the micro undulator; beam diagnosis which controls the laser and electrons, accurately directing the accelerated electrons into the undulator; plasma technology for staging acceleration of electrons to higher energy and a power supply that rise up quickly required for the plasma control.
- ② **Ultra compact power laser:** Develop a microchip laser with a weight of 1 kg that outputs more than 20 mJ of energy per pulse, and a high output compact power laser that outputs several joules of energy at 100 Hz or more.

③ **Systemization assessment:** Benefits to users are evaluated for the developed technologies of laser acceleration & XFEL demonstration and ultra compact power laser. Market needs for these technologies are explored.

Hitherto, ordinary people were totally unable to make use of the XFEL, a National Critical Technology. But when high-power pulse lasers including XFELs are made ultra compact, anybody will be able to use them. As a result, in future, measurement at the atomic level will bring about industrial innovation. It will be used in a wide range of applications such as ubiquitous facility diagnosis and repair, advanced medical care such as bioimaging and ion beam radiotherapy, and security.

Achieving Ultimate Green IT Devices with Long Usage Time without Charging

Achievement of the ultimate in energy savings of a computer through the use of the ultimate non-volatile memory and spintronics logic integrated circuits

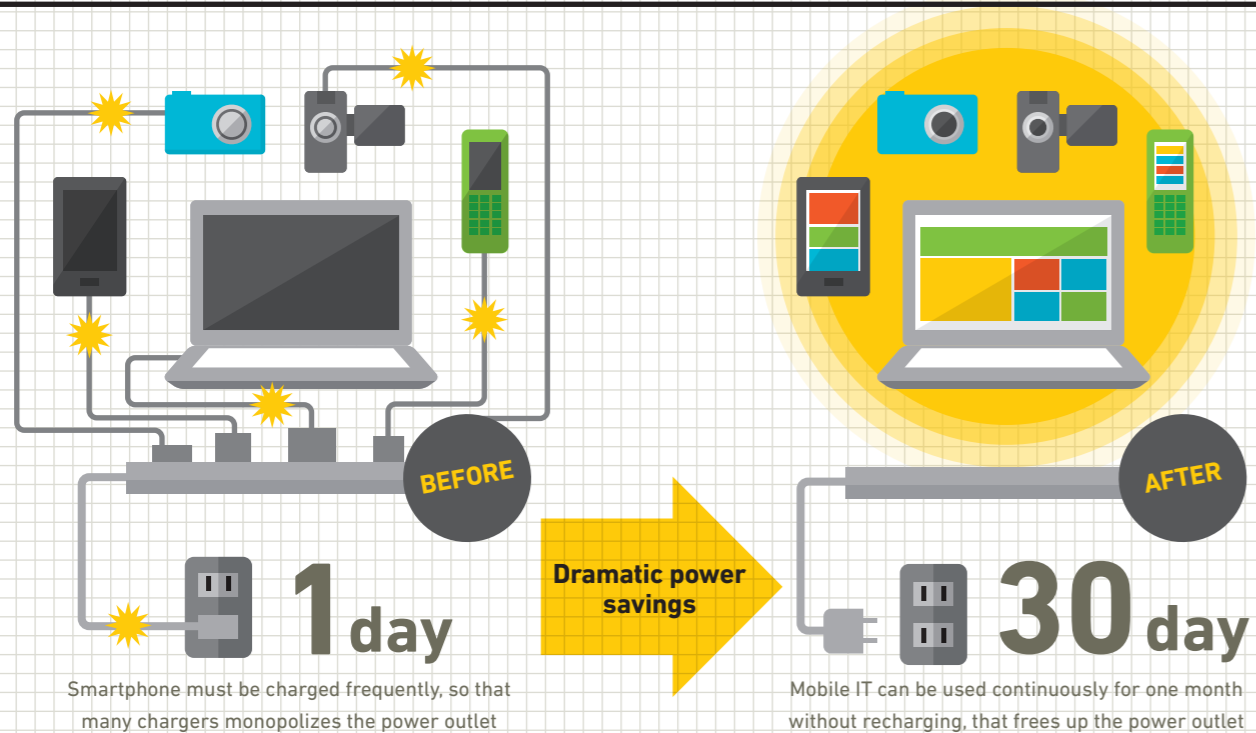

Information and communication technologies have greatly changed our daily life-style through the widespread use of mobile devices and cloud computing. But conventional mobile devices must be recharged frequently, and the number of rechargers that must be left plugged into power outlets continues to increase, which results in the increase in wasting energy. Finding ways to decrease energy consumption which is increasing further with the use of "big data" and the Internet of Things (IoT), is a serious issue that our society faces. This program will resolve this societal issue through technologies such as the ultimate in non-volatile memory that uses voltage to record data to magnetic memory, and spintronics logic integrated circuits that consume little power, in order to achieve ultimate power savings at each computer memory and storage level. This will reduce the power consumption of IT devices down to the possible lowest level and creates a pleasant and environment-friendly IT society free from the stress of recharging, as well as a safe and secure society that enables access to information even in the event of a major disaster.

Message

When I was in the elementary school, I was aggressive and considered as an outsider, and in this sense I have not changed at all. It may be true that I dislike the manner not to take a risk, in other words, the attitude of "it won't be scary to cross the bridge if we all do it together." People often tell me that I do only the things that I want to do, and it is true that I can't get both of will and passion to do something unless I really like it. When I look back, I think the most motivated time was when I was working to rebuild the research field that was in critical state. These things should be ordained by providence. I've tried many different challenges without fear of failure. My motto has been to train young people and nurture new ideas. Although I've made a lot of mistakes so far, but it is very important to take on challenges, preferably major challenges from the early stage of development even if everyone opposes those. If you carry out that, I'm convinced that you will find the way forward. I believe firmly that is the ImPACT spirit.

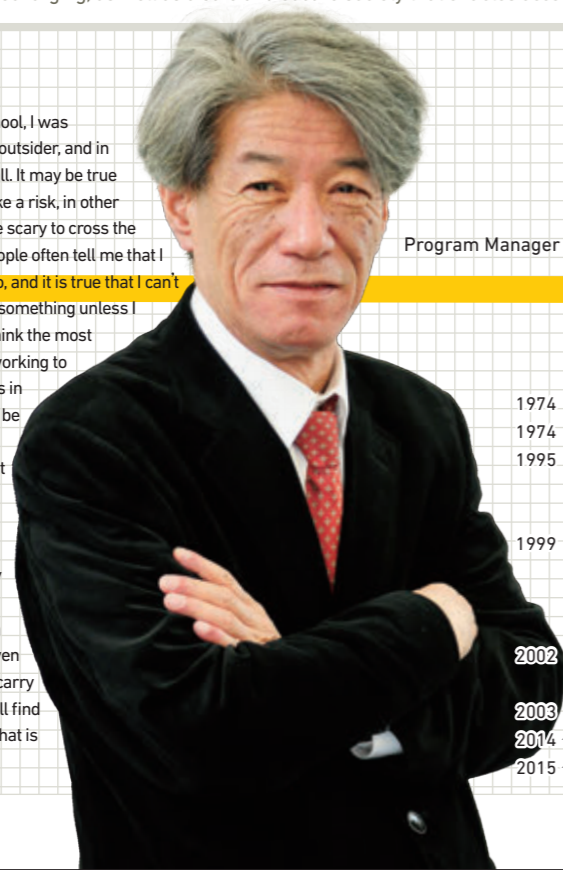

Program Manager

Masashi SAHASHI
佐橋 政司

- 1974 Graduate, Nagoya University Master's Course
- 1974 Researcher, Toshiba Research & Development Center
- 1995 Project Manager, Toshiba Research & Development Center
Recipient of the Nikkei BP Technology, Grand Award (for development of the world's first HDD with a GMR head)
- 1999 Senior Fellow, Toshiba Research & Development Center
Recipient of the National Institute of Science and Technology Policy Award (for research achievements)
Received Onshi Invention Award
- 2002 Doctorate, Engineering (Nagoya University Graduate School)
Received the Shijuhosho (Medal of Honor with Purple Ribbon)
- 2003 Professor, Tohoku University Graduate School of Engineering
- 2014 ~ ImPACT Program Manager
- 2015 ~ Research Professor, Tohoku University

Recording data using "voltage" through the use of cutting-edge spintronics technology based on non-volatile memory

The electronic devices that make up present computers have a fundamental problem: the large amount of power consumption by every component of CPU, memory and storage. DRAM, SRAM and other volatile memory components require a constant supply of power to store and preserve data. In contrast, nonvolatile memory preserves data even when the power is turned off. This results in the reduction of standby power. During operation, however, even nonvolatile memory consumes power since the current flow is needed to write data.

Accordingly, the goal of this program is to use the cutting-edge spintronics technology based on nonvolatile memory to achieve the voltage control for spin memory and other devices that store the information data. Spintronics is a field of science and technology that has applications in engineering fields such as data recording and

transmission. In spintronics, the spin, that is the basis of a magnet, can be controlled in addition to electron charge. The use of spintronics devices would enable data to be preserved even when the supply of electricity is cut off. The power is supplied only during data read and write operations. Moreover, as the power does not need to be supplied to the entire integrated circuit but only to those areas that are used, the power consumption can be dramatically reduced.

This program will develop a new integrated circuit that utilizes this spintronics technology. Another innovative aspect of the research is the use of voltage (electrical field) to exercise the device control as opposed to the conventional research which mainly uses the electrical current for the device control. Since almost no current is supplied to the device, heat

generation can be kept to the minimum. The ultimate goal is to ensure that the data is retained for a long time even when the power is turned off, and to reduce the power consumption for the device operation to one 100th of that of existing devices.

The course of development of this "shift from current to voltage" is expected to be the same as the evolution of conventional electronics which uses only electron charge: from vacuum tubes, through current-driven bipolar transistors, to voltage-driven field-effect transistors (FETs). If the disruptive innovation can be achieved even in the world of the spintronic devices from current-driven to voltage-driven operation, which has been thought to be impossible, then a major "game-change" could be caused.

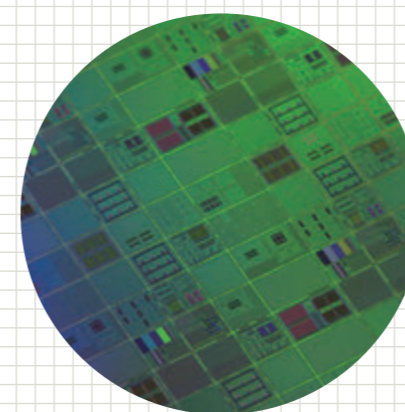

Non-volatile logic integrated circuit

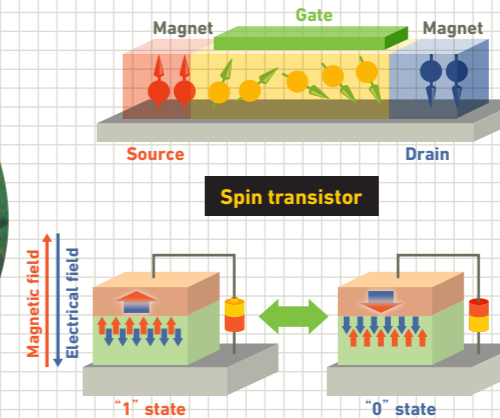

Voltage writing type magnetic storage

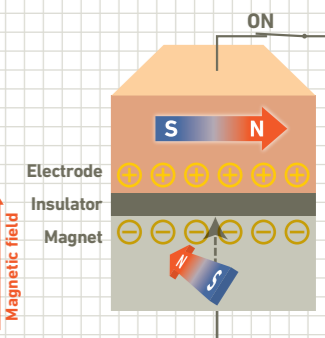

Voltage torque MRAM

The goal of this program is to develop innovative technologies that will bring about discontinuous innovation, such as the use of the ultimate in non-volatile memory (which can record data to a magnetic memory chip using voltage) and spintronics logic integrated circuits (which have low power consumption) for the computer memory and storage levels. This would reduce the power consumption by mobile devices to the lowest possible level and achieve the environment-friendly IT society free from the stress of recharging, dramatically transforming lifestyles, and a safe and secure society.

Transformation to pleasant environment-friendly lifestyles and a safe, secure and ubiquitous IT society

As this program involves an extremely high level of difficulty, an all-Japan roster of leading researchers and research organizations in the field of spintronics are assembled to perform research activity in the following five project areas.

- ① **Spin transistors:** The goal of this project is to achieve the spintronic nonvolatile transistor. A prototype spin FET chip that directly injects spins into a CMOS structure will be created and its superiority over conventional CMOS transistors in terms of low power consumption and greatly reduced circuit integration will be demonstrated. This technology will also introduce non-volatile functions to CPUs.
- ② **Voltage torque MRAM:** The ultimate nonvolatile memory that is capable of high-speed operation and ultra-low power consumption writing (which in principle requires almost no current) will be developed, and the fundamental technology for

mobile IT devices that can be used for a long period of time without recharging will be developed.

- ③ **Single crystallization / High and 3D integration:** The limitation on memory miniaturization will be overcome through the development of the first single-crystal 3D device in the magnetic recording and spintronics field. The new device will achieve the requirement for the cache memory (MRAM) of 10 nm line width generation...
- ④ **3D storage (cross correlation voltage writing magnetic storage):** A new voltage-writing magnetic recording principle that utilizes the electromagnetic effect will be demonstrated, establishing the fundamental technology for ultra-high recording density of 5TB per square inch achieved through 3D design.
- ⑤ **Distributed IT system using spintronics integrated circuit:** A microprocessor with ultra-low power consumption and processing

capacity equivalent to conventional mobile devices, which can be operated by energy harvesting (harvesting minute quantities of energy from the ambient environment and converting this energy to electrical power), will be developed. Application of this technology will establish the fundamental technology for distributed IT systems.

These overwhelmingly distinct technologies will provide the breakthrough for the revitalization of the electronics industry in Japan and will prime the creation of the ultimate environment-friendly IT devices. Moreover, applying these new technologies to mobile IT devices, cloud concentrated IT systems, sensor networks and other distributed IT systems will result in the revolution of our convenient, environment-friendly lifestyles, achieving a safe, secure and ubiquitous IT society.

Innovative Cybernic System for a "ZERO Intensive Nursing-care Society"

Challenge of implementing in society an innovative cybernic system to reduce the heavy burden on individuals, families and society

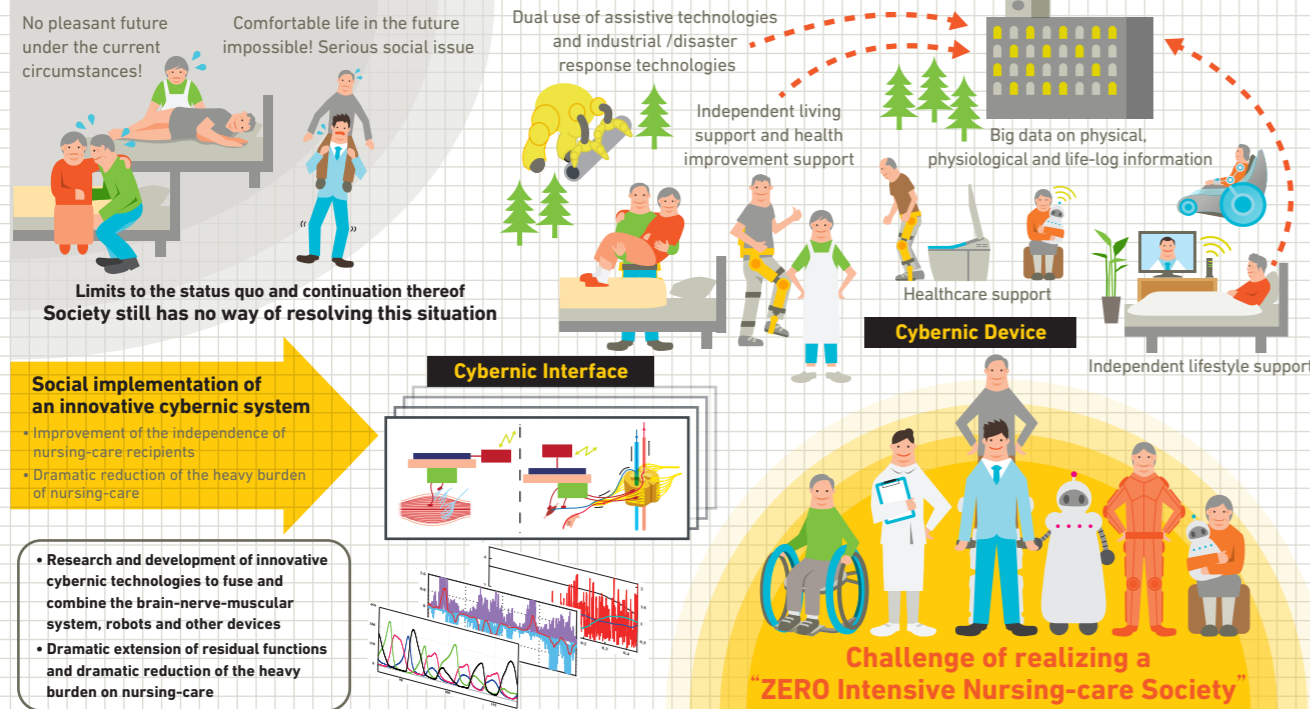

Intensive nursing-care is a common and serious social problem in advanced countries with high longevity. In this program, an innovative cybernic system that fuses and combines the brain-nerve-muscular system, robots and other devices, improves/extends/amplifies/assists the residual functions of human beings. PM's challenges are to promote the creation of new industries using the innovative human support technologies, to realize a "ZERO Intensive Nursing-care Society," to realize a paradigm shift from the conventional consumption economy to the social problem-solving economy, and to realize industrial and social innovations, by implementing the proposed technology in society as a life-support infrastructure.

Message

This program focuses on the intensive nursing-care society, which is an unresolved social problem for all countries. In order to resolve this serious problem, our challenges are to research and develop an "Innovative Cybernic System" that fuses and combines the brain-nerve-muscular system, robots and other devices, and to realize a "ZERO Intensive Nursing-care Society" by constructing a life-support infrastructure and promoting social implementation of these innovative human support technologies. We hope to create new industries using the proposed technologies, and to realize a paradigm shift from a consumption economy to a social problem-solving economy for industrial and social innovations.



Program Manager

P M

Yoshiyuki SANKAI
山海 嘉之

- 1987 received Ph.D. degree in engineering from the University of Tsukuba
- 1998 Visiting Professor, Baylor College of Medicine in Houston, U.S.
- 2003 Professor, Graduate School of Systems and Information Engineering, University of Tsukuba
- 2006 CEO, CYBERDYNE Inc.
- 2009-2014 Principal researcher, FIRST Program organized by the Cabinet Office of Japan
- 2011 Director, Center for Cybernics Research, University of Tsukuba
- 2014 ImPACT Program Manager

Support for caregivers and nursing-care recipients by using the Cybernic Interface / Device / System

This program aims to resolve the intensive nursing-care problem, which places a heavy burden on families and society, by using the Cybernic Interface/Device/System to realize fusion/combination technologies that fuse humans and robots. The Cybernic Interface processes intentional and sensory information through the brain-nerve-muscular system, and also receives, manages and provides information on the physiological state. The Cybernic Device supports the movement/excretion/physiological management of caregivers and nursing-care recipients, including patients, on the basis of that information. In addition, this program promotes the research and development of the Cybernic System, which is operated in conjunction with the interface and the device as life-support infrastructure technology, to demonstrate and validate ZERO intensive nursing-care in certain local community fields.

In order to clarify the exit strategy for this program, this section introduces four typical objectives and the specific approach corresponding to each objective from the viewpoints of caregivers and nursing-care recipients.

A life-support infrastructure using the innovative cybernic system is implemented in our society together with a collaborative innovation platform that ensures a continuous virtuous cycle of innovation. We promote the creation of new industries with innovative human assistive technologies that are a fusion of humans, robots and other devices, and thereby aim to achieve a "ZERO Intensive Nursing-care Society."

R&D Team Organization / Management and Research Promotion / Future Prospects

Realization of industrial and social innovations: Creation of innovative technology to fuse humans, robots and other devices, certification by international standards, and establishment of an operating environment

A rapidly increasing number of senior citizens and patients who are bedridden or require nursing-care, along with the declining birthrate and aging population have resulted in the need to deal with the "intensive nursing care problem." This problem, which increases the burden on families and society is a serious and unresolved problem common to advanced countries with high longevity. The goal of this program is to achieve a "ZERO Intensive Nursing-care Society" through the following three projects that are designed to support both caregivers and persons requiring nursing-care.

- Project ① (Cybernic Interface):**
 - To process the information of the brain-nerve-muscular system in order to support movement/excretion/physiological management
 - To function independently and in conjunction with the Cybernic Device
 - To develop the Cybernic Interface in accordance with international standards (ISO13482/13485)
- Project ② (Cybernic Device):**
 - To support the movement/excretion/ physiological management of nursing-care recipients, including patients
 - To support nursing-care associated with

Nursing-care recipients

- ① Nursing-care recipients, including patients, are able to get out of bed under partial or light nursing-care, and move to a desired location, e.g., toilet, and then get back into bed. To achieve this objective, we research and develop interfaces, devices and systems that improve and extend their residual physical functions.
- ② Nursing-care recipients, including patients, are able to move to a desired location, e.g., toilet using the proposed innovative technologies, and perform a desired action, e.g., sitting down and excreting, and then return to bed or their living space. To achieve this objective, we research and develop interfaces, devices and systems that improve and extend their independence.

Caregivers

- ① Caregivers are able to lift nursing-care recipients from their bed, transfer them to a wheelchair, transport them to a toilet, and then seat the person on the toilet seat. To achieve this objective, we research and develop interfaces, devices and systems that reduce the caregiver's burden dramatically.
- ② Caregivers are able to support the movement and excretion of nursing-care recipients while reducing their burden from the viewpoint of safety management. To achieve this objective, we research and develop interfaces, devices and systems that manage the physiological state of the caregivers and nursing-care recipients during the provision and receiving of nursing-care support associated with movement/excretion/physiological management.

Towards a "ZERO Intensive Nursing-care Society!"

- Improvement of the independence of nursing-care recipients
- Dramatic reduction of the heavy burden of nursing-care

- Gather seeds and human resources from Japan and worldwide
- Promote the acceptance of collaboration

Paradigm shift from a consumption economy to a social problem-solving economy

Creation of innovative human support industries!
Industrial and social innovations: Economic cycle through social business

Integrated promotion of R&D of innovative technologies, safety verification, actual evaluation, international certification, new market development, and human resource development

"Spiraling-up Innovation"

organization managing the collaborative innovation platform is established to ensure that the assessment results at each phase of research and development are reflected in the specifications for development and verification at each stage, creating a virtuous cycle and enabling comprehensive management that leads the participating organizations in a flexible, strategic and dynamic approach. The ImPACT R&D Promotion Core also proposes and promotes behavioral models which form the basis of the collaborative innovation platform, and promotes collaboration with participating agencies to form a Cybernics Excellence Japan consortium for the commercial development of the program's achievements, in order to establish partner organizations for the creation of new industries and to implement activities aimed at demonstrating the basic mechanisms for a social business model. In this way, the creation of new industries by using innovative human support technologies to fuse humans, robots and other devices, will produce a paradigm shift from the conventional consumption economy to the social problem-solving economy, and lead to industrial and social innovations.

Super High-Function Structural Proteins to Transform the Basic Materials Industry

Learn from the natural world and use super-high-function structural proteins, such as those possessed by spiders and fleas, as materials

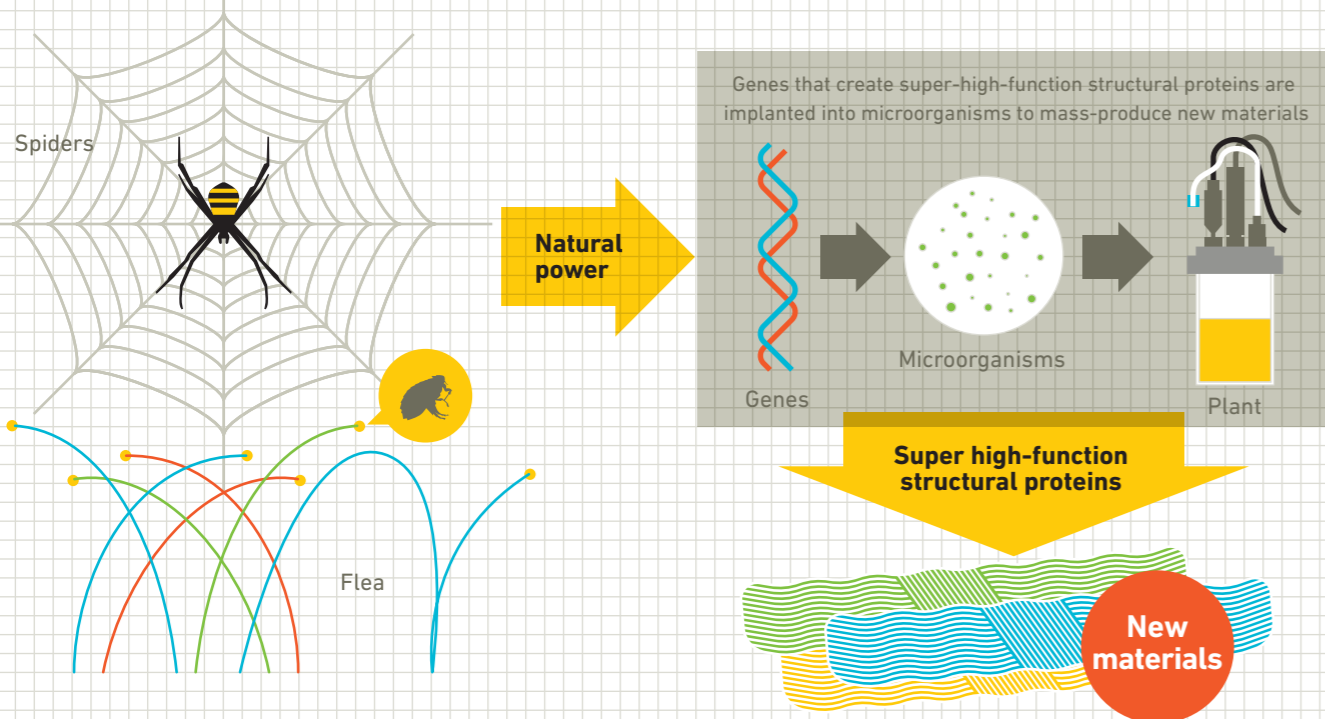

Conventional manufacturing industries are dependent on oil, metals, ceramics and other natural resources that may be exhausted in the future. The goal of this program is to learn from the natural world and create super high-function next-generation materials that will dramatically improve Japan's industrial competitiveness. For example, genes for producing super high-function structural proteins that surpass spider's silk, which has 340 times the toughness of steel by weight, will be implanted into microorganisms to enable synthetic mass-production. The mechanisms that produce performance on a different dimension will be identified to establish the foundation for new material design and processing technologies, in order to bring about an industrial revolution in materials and free ourselves from the existing structure of industry.

Message

The goal of this program is to create a new industrial revolution in materials through the use of super-high-function structural proteins. This will enable us to get away from the existing industrial structure that is dependent on exhaustible resources and achieve a dramatic improvement in Japan's industrial competitiveness. In order to develop and commercialize next-generation materials such as spider's silk that offer performance on a different dimension as compared to existing materials, young leaders at Japan's major academies and companies that will lead the next generation will be hand-picked to pursue out-of-the-box research and development to break through the technical barriers that humanity has not yet overcome.



Program Manager

P M

Takane SUZUKI
鈴木 隆領

- 1982 Graduated Shizuoka University Faculty of Engineering
- 1987 Joined Kojima Industries Corporation
- 2010 Head of Development and Director, Kojima Industries Corporation
- 2014 ~ ImPACT Program Manager

Identification of the mechanisms that produce high functionality in structural proteins to create new materials with unparalleled functions

In this program, world-class, state-of-the-art, high-order structural analysis technologies, CS/IT, genetic engineering, synthetic biology, materials science and production technologies will be brought together to manufacture and promote commercial development of lightweight next-generation materials with overwhelming toughness by means of microbial fermentation. Structural protein materials that combine performance on another dimension, outstanding environmental friendliness, freedom of design and innovative cost structure will be the key to resolving issues. In order to achieve such materials, the following approaches will be used to resolve issues.

First, structural design techniques for protein materials that use gene synthesis technology will be established. To this end, genetic sequences for super-high function structural proteins in nature, such as spider's silk, will be identified, after which their physical properties will be measured and structural analysis will be performed. The results will be compiled in a database to identify the mechanism by which advanced functions are produced in structural proteins. This database and the knowledge learned through this process will be used to artificially synthesize super-high function structural proteins whose properties go beyond those of natural materials, in order to create new structural protein materials.

However, the search for new molecules that strike a balance between advanced functions and productivity by means of microbial fermentation will be extensive, and a piecemeal trial-and-error approach is unrealistic. Structural analysis of proteins will be performed through the use of the SPring-8 facility that employs cutting-edge synchrotron radiation technology and next-generation sequencers for comprehensive sequencing

analysis, and the resulting knowledge will be collected and integrated to verify hypotheses. This process will be repeated to efficiently narrow down the candidate molecules. Next, the target super-high function protein materials will be produced, and next-generation transportation equipment members and bulletproof and protective gear and other applications will be developed. During this process, the factors that may affect protein

materials during processing will be identified and processing technologies that are specially designed for these materials will be developed. These processes will ensure prototype verification for the ultra-high toughness materials with properties that ultimately exceed the highest found in nature, as well as product prototyping, manufacture on the scale of several tens of thousands of tons, and cost evidence that the materials can be used as industrial materials.

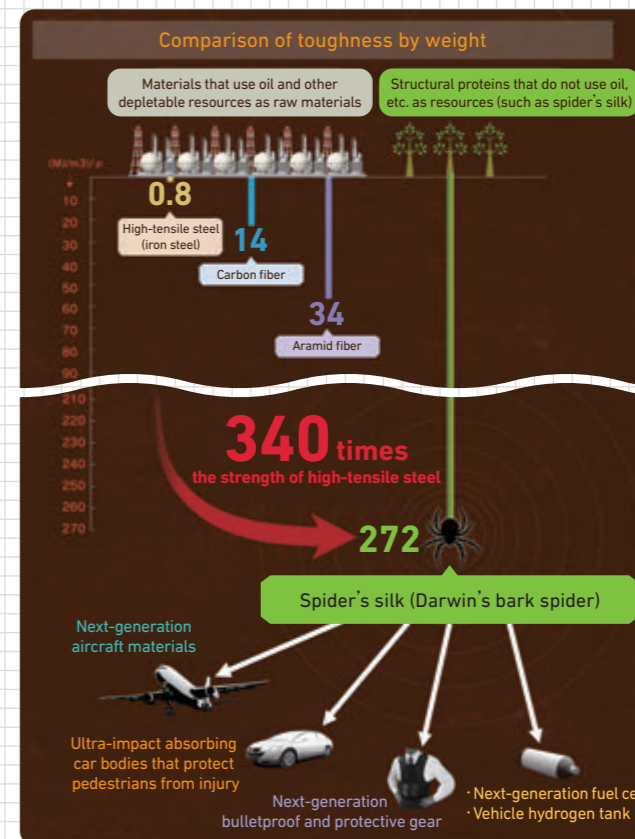

Toughness of spider's silk (structural protein) and its applications

Structural proteins such as spider's silk have extraordinary performance not possible with existing materials and can be manufactured without relying on depletable resources such as oil, and therefore they have the potential to become key next-generation materials. For example, spider's silk is said to have a toughness that is 340 times that of high-tensile steel. Using materials with such extraordinary performance would make it possible to create products with performance that exceeds that of existing products in a wide variety of fields, such as transportation equipment and bulletproof and protective gear.

Ultra-interdisciplinary feedback organization that can conduct research and development with mutual support among teams

In this program, the following four projects will be established to resolve the major issues of "Design and production of super-high function protein materials using large-scale genomic information" and "Development of basic technologies for fabrication of super-high function protein materials."

- ① **Comprehensive analysis of natural high-function proteins and unraveling of the mechanisms behind extreme functionalities:** Sampling of natural protein primary materials and live specimens, DNA sequencing analysis, quantification of properties and molecular structures of natural protein primary materials, creation of an integrated database for the analysis data for natural high-function protein materials, and functional / structural analysis of natural high-function protein primary materials and synthetic fibers.
- ② **Creation of super high-function structural protein primary materials whose capabilities**

exceed those of natural proteins: Formulation of a hypothesis for molecule design, genetic design and synthesis, manufacture (culturing) of synthetic proteins, spinning of fibers, and measurement of properties of synthetic fibers

③ **Development of processing technologies and application technologies for biofibers:** Development of elemental process technologies for industrial use of proteins

④ **Product prototyping and evaluation including dual use:** Use of the basic technologies developed in ① - ③ to begin prototyping of composite materials that demonstrate overwhelming performance not possible with existing materials

To enable the individual teams to complement one another's technologies and promote efficient and effective joint research and development, an ultra-multidisciplinary feedback type research and development organization will be established. Dissemination and increased competitiveness for

the industry as a whole will be promoted through open innovation of application development, in addition to standardization and normalization for related technologies, packaging of patent groups and the drafting of intellectual property strategies relating to core technologies, in order to enable Japanese companies to firmly seize the initiative in the industry.

Future efforts will include the development of ultra-impact absorbing car bodies that protect pedestrians from injury, hydrogen tanks for next-generation fuel cell vehicles, next-generation ultra-lightweight bulletproof gear, next-generation transportation equipment primary materials and so on. This freedom from resource constraints will achieve Japanese-style product development for the new millennium, in the form of a supply center for advanced component primary materials that balance environmental friendliness with ultra-high functions.

Tough Robotics Challenge (TRC)

“Tough” fundamental technologies (accessibility in extreme environments, extreme sensing, recovery from failure, and extreme environment compatibility)

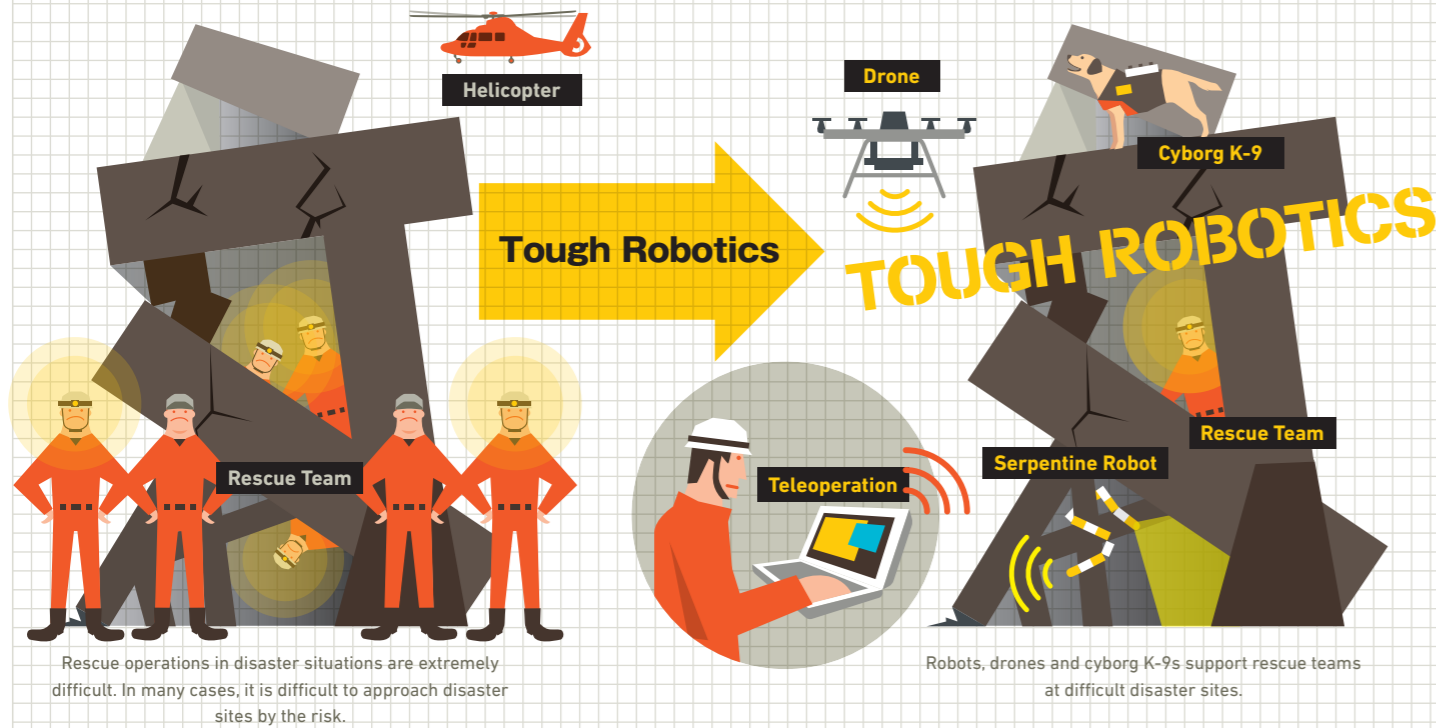

Japan is one of the most disaster-prone countries in the world. A large-scale earthquake is predicted to occur directly beneath the Tokyo metropolitan area in the near future, and there is an urgent need for measures to reduce the risk. Although the usefulness of robots in a disaster was recognized during the Great East Japan Earthquake, robots that can actually be used in unknown extreme environments where the situation is always changing are still a work in progress. The goal of this program is to develop essential technologies for remote autonomous robots that are tough and can function without faltering even in an extreme disaster conditions. At the same time, this research provides key fundamental technologies for outdoor service robots for establishing foundation of the future advanced outdoor robot services.

Message

After the Great Hanshin-Awaji Earthquake of January 17, 1995, I realized that building robotics that can provide solutions to the enormous social problems of disaster was an issue of crucial importance. At the time of the Great East Japan Earthquake in 2011, various types of robots were applied for the first time in human history, but there were limits to their effectiveness. The reason is that current robots are like “delicate goody-goodies.” The goal of the Tough Robotics Challenge is to develop technologies for hardcore robots that can function under extreme conditions.



Program Manager

Satoshi TADOKORO
田所 諭

- 1984 M - Eng., Univ. of Tokyo
- 1993 - 2005 Associate Professor, Kobe University
- 2002 Established International Rescue System Institute
- 2002-2006 MEXT DDT Rescue Robotics PM
- 2005 ~ Professor, Graduate School of Information Sciences, Tohoku Univ.
- 2006-2010 NEDO Strategic Advanced Robot Component PI
- 2011 Deployed Quince for the Fukushima-Daiichi Accident
- 2012 Assistant Dean, Tohoku University
- 2014 Vice Dean, Tohoku University
- 2014 ~ President-Elect, IEEE Robotics and Automation Society
- 2014 ~ ImPACT Program Manager

Development of fundamental technologies for robots that can perform tough work under extreme conditions

Robots are expected to play a major role in the event of earthquakes, tsunamis, wind and flood damage, volcanic eruptions and other major disasters that occur all too frequently, as well as in inspections of aged plants, buildings and infrastructure, in decontamination operations in the event of nuclear power plant accidents and reactor decommissioning, and in other dangerous locations where human beings cannot enter. But conventional robots still have many unresolved issues, including immobility at disaster sites (unable to move), inability to ascertain the status of the disaster (unable to see and hear), total lockdown in the event of failure (unable to recover), or not being suited to the working conditions (unable to be compatible with specific environments).

The goal of this program is to establish “tough” fundamental technologies (accessibility, sensing and perception, recovery from

failures, and environmental compatibility) in order to resolve the deficiencies of the current “delicate goody-goodies” to make robots fully effective in extreme conditions. In addition, repeated field tests with robots and wide-range of component technologies will make it possible to give solutions for disaster preparedness, response and recovery.

Specifically, objectives will be achieved in three aspects: technology, industry and society. Advanced technologies will be developed for active robustness, large-scale realtime information and bio-machine fusion. Five different robot bodies will be developed and component technologies will be integrated to establish “Tough Robotics” for robots that are able to function in disaster conditions. Research and development areas will also include movement under difficult circumstances, image recognition in poor visibility, ultra-high

resolution sensor data, soundsource separation in noisy environments, and big data analysis that enables vague signs to be read.

In terms of the industry, creation of new businesses of component technologies, services and robots using the outcome of this project will be encouraged. Field testing in simulated application sites will be performed regularly, and R&D and business matching based on the field evaluation will be pursued and coordinated with both disaster prevention projects and company-specific business planning. In terms of the society, disaster mitigation solutions will be provided to enable information gathering and operations even under severe environmental conditions where these are currently difficult, with aiming at achieving safe, secure and rich society.

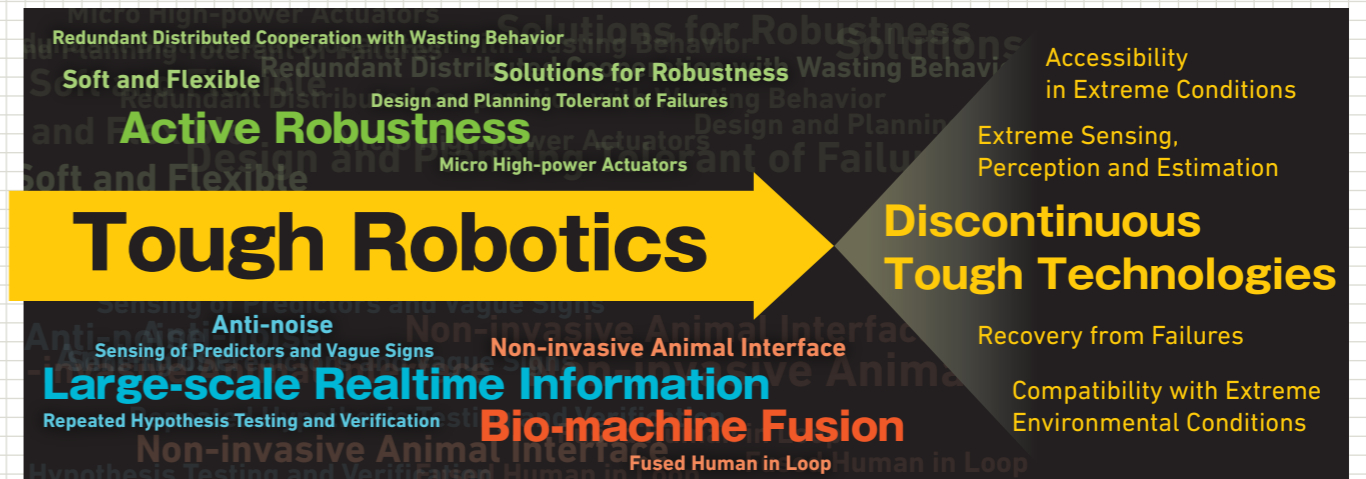

Disruptive Innovation for Tough Robotics

The core technologies of Tough Robotics have three keywords: “active robustness,” “large-scale realtime information,” and “bio-machine fusion.” These will achieve disruptive innovation of the toughness that robots can move in extreme conditions, perceive extreme situations, recover from failure, and be compatible with the extreme working conditions.

Development of robotics for tough robots by research teams with collaboration and competition

This program is made up of the following five projects. These projects will be promoted based on collaboration between world-class researchers who research the top-class technologies, users who deploy the new solutions, and companies committed to new business development.

1 Robot Platforms: Five types of robot platforms will be developed: aerial robots (drones), legged robots (transformer-type robots), compound robots (construction machinery robots), string-type robots (serpentine robots), and animal cyborgs (rescue K-9s equipped with digital equipment). Various component technologies of Tough Robotics Challenge will be integrated into these robots.

2 Robot Components: Research and development of hardware component technologies such as ultra-high output hydraulics and extreme mechanisms will be pursued.

3 Robot Intelligence: Research and development of software and sensor technologies such as extreme sensing and analysis, recovery, and human interfaces will be pursued.

4 Field Testing, Evaluation and Safety: Outcomes will be evaluated at field tests, and robot safety is studied at the same time.

The hardware components developed in 2 and the intelligent software and sensing technologies developed in 3 will be integrated with the five types of robot bodies developed in 1. In 4, field testing and evaluation and safety demonstration tests will be conducted to link the outcome with users and companies.

In the field tests, robots and component technologies are tested using the simulated test fields, and comprehensive testing will also be performed at outdoor situations. Some tests will be open to public in order to induce friendly

competition among researchers and to encourage sharing of information and collaboration. User views will be reflected in the testing condition in order to consider actual needs in this fundamental research. Outcomes will be proposed as solutions for users, and it will stimulate business insights of companies.

In this way, robots will be used for disaster preparedness, response and recovery to contribute to the safety and security in the world. The future ripple effect of the technologies will open the way to advanced outdoor robot service business and dissemination in the future.

Reduction and Resource Recycling of High-level Radioactive Wastes through Nuclear Transmutation

Measuring of world-first data on nuclear reactions in order to propose a process for nuclear transmutation and establish new methods for control of nuclear reactions

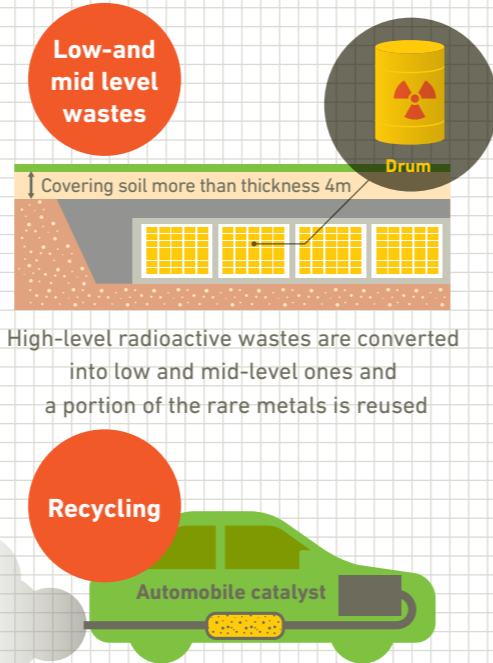
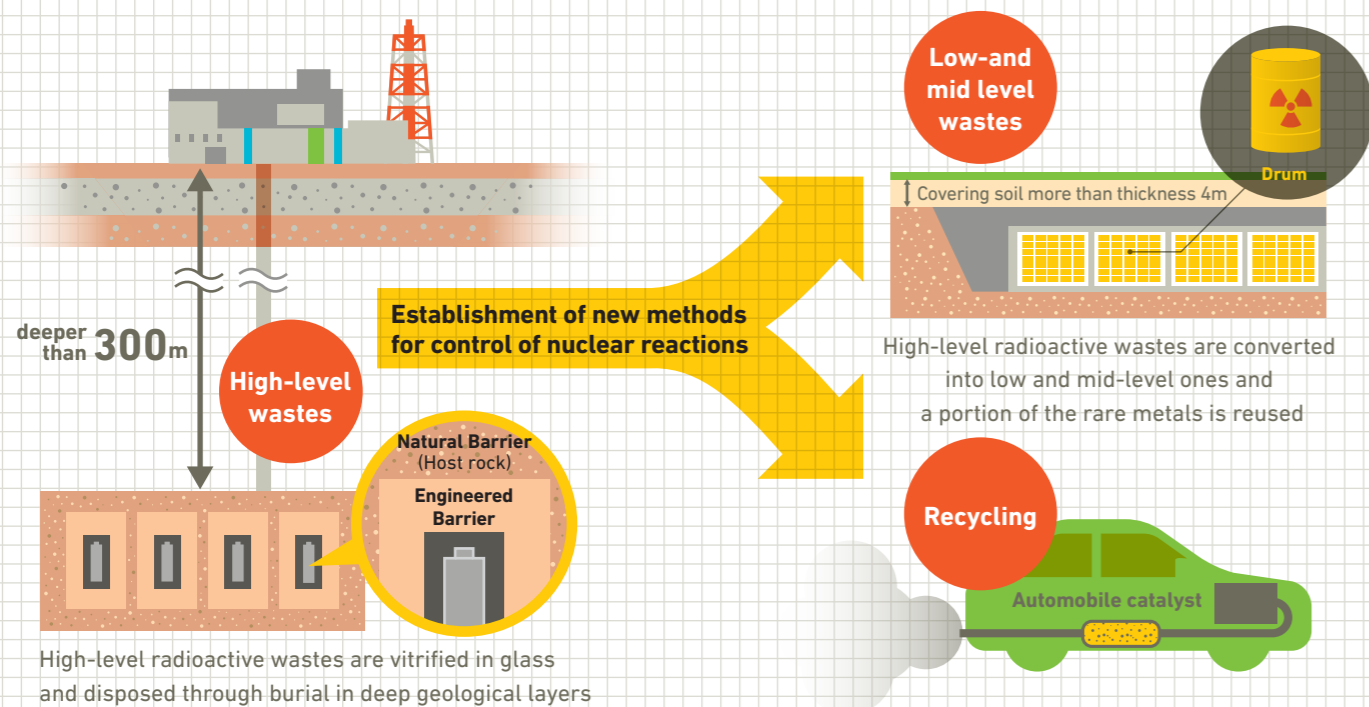

High-level radioactive wastes are converted into low and mid-level ones and a portion of the rare metals is reused

Recycling Automobile catalyst

High-level radioactive wastes are vitrified in glass and disposed through burial in deep geological layers

The high-level radioactive wastes produced when the spent fuel from nuclear power plants is reprocessed must be disposed of through vitrification in glass solid and burial in deep geological layers. As these wastes contain nuclides with a long half-life, public concern remains over the long-term storage of such wastes. There is also a social problem in terms of the difficulty to determine disposal sites for these wastes. The goal of this program is to investigate the nuclear reaction paths for long lived fission products (LLFP), for which disposal in the deep layer has been the only option. The establishment of reasonable nuclear transmutation methods will enable these wastes to be converted into stable nuclides or short-lived ones. I will also make efforts to develop ecological systems for the reuse of the rare metals and other resources that are included in the recovered products.

Message

Converting the fission products with a long half-life that are included in high-level radioactive wastes into stable, non-radioactive substances is extraordinarily difficult. But unless someone challenges this difficult research topic head-on, there will be no possibility of reducing high-level radioactive wastes, and the inability to determine disposal sites for these high-level radioactive wastes will remain a problem. The goal of this program is to find a new and unprecedented path to the nuclear transmutation of wastes and confirm this path through experiment, in order to actually deal with one of the fundamental problems of nuclear power.

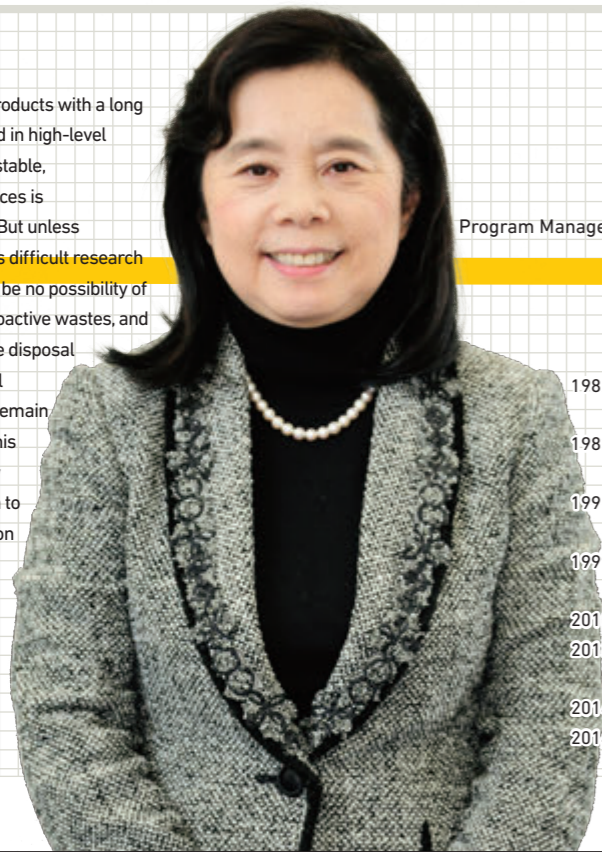

Program Manager

P M
Reiko FUJITA
 藤田 玲子

- 1982 Received Ph.D from Interdisciplinary Graduate School of Science and Engineering, Tokyo Institute of Technology
- 1983 Joined Toshiba Corporation (Nuclear Technology Research Laboratory)
- 1995 Received Atomic Energy Society of Japan Award for Distinguished Technology
- 1999 Received Atomic Energy Society of Japan Best Paper Award and many other awards
- 2010 ~ Director, Atomic Energy Society of Japan
- 2012 ~ Chief Fellow, Power and Industrial Systems Research and Development Center, Power Systems Company, Toshiba Corporation
- 2014 ~ President, Atomic Energy Society of Japan
- 2014 ~ ImPACT Program Manager

Finding a path to convert four types of long-lived nuclides (including cesium 135 and palladium 107) into short-lived or stable ones

The progress of accelerator science in Japan has made it possible to obtain data on various types of reactions that could not be obtained previously. If data on the cross-sectional area of the nuclear reaction and other aspects of the long lived fission products (LLFP) contained in high-level radioactive wastes could be obtained, it might be possible to propose reasonable nuclear reaction processes paths, and to establish a technology for nuclear transmutation to convert these materials into short-lived nuclides or stable ones.

The goal of this program is to separate and recover the long lived fission products (LLFP) contained in high-level radioactive wastes and develop the technology needed to perform nuclear transmutation in order to convert these materials into short-lived nuclides or stable ones, and also to develop an ecological system for the reuse of the platinum group metals and

rare earth elements contained in these products. The program will focus on four nuclides: cesium 135 (half-life 2.3 million years), palladium 107 (half-life 6.5 million years), zirconium 93 (half-life 1.53 million years) and selenium 79 (half-life 295,000 years).

The first step was to study the existing research on group separation and nuclear transmutation in the nuclear reactions inside a nuclear reactor. During the nuclear reactions in a nuclear reactor, neutrons strike stable nuclides as well, creating nuclides with a long half-life. The key point for this program will be using an accelerator to control the neutron energy and find the nuclear transmutation (to establish a nuclear reaction process without isotope separation). Once new nuclear reaction processes paths are discovered, the target nuclides can be converted into stable nuclides using the appropriate method of nuclear transmutation.

In order to achieve this, the RI Beam Factory (a state-of-the-art acceleration facility) and other facilities will be used to obtain world-first nuclear reaction data. Bulk nuclear reaction simulations (using the substance itself that is not in contact with the interface) will be performed based on the data, in order to propose nuclear transmutation methods that do not involve isotope separation and methods for controlling the reactions of neutrons that are produced by the nuclear reaction. In addition, engineering studies that integrate these processes and reasonable process concepts will be proposed.

One more goal is recycling following nuclear transmutation. Platinum group nuclides will be recycled as automobile catalysts etc., and rare earth elements will be recycled as rare metals. These technologies will achieve a resource market that is not affected by overseas markets and does not burden future generations.

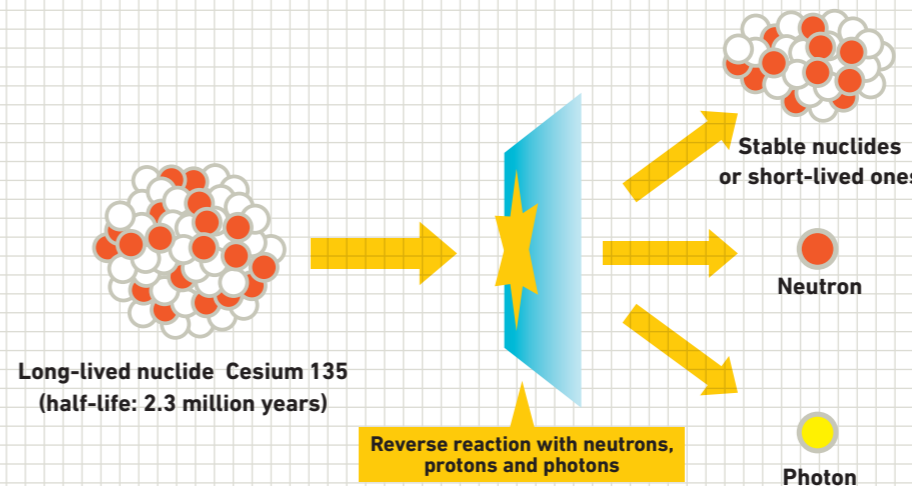

Example of measurement of nuclear reaction data

The technology needed to separate and recover the long lived fission products (LLFP) included in high-level radioactive wastes and perform nuclear transmutation to convert them into short-lived nuclides or stable ones will be established. As a first step, in order to propose and confirm the ideal nuclear reaction path, the accelerator facility such as RI Beam Factory and other facilities will be used to obtain world-first data by means of high-intensity beams + reverse reaction science methods.

Finding a path to convert four types of long-lived nuclides (including cesium 135 and palladium 107) into short-lived or stable ones

The management strategy for this program will be to grow into one and coordinate most advanced nuclear physics and nuclear power engineering. Multiple companies will also participate in this effort in preparation for future deployment. The process will begin with the measurement of world-first data and will proceed quickly to engineering development. Research and development will be pursued for the following five projects.

- ① **Development of separation and recovery technologies:** Promising technologies for recovering LLFP from high-level radioactive wastes will be selected based on an assessment of separation and recovery performance, amount of secondary waste and economic evaluation, and the data will be provided to Project ⑤ (Process concept for design).
- ② **Obtained nuclear reaction data & new nuclear reaction control method:**

Physical experiments will be performed at the RI Beam Factory (RIBF) and J-PARC / RIKEN RAL and other state-of-the-art facilities to obtain world-first data. New methods for control of nuclear reactions will be developed based on the measured data.

- ③ **Reaction theory modeling and simulation:** Reaction theory and structural one will be used to complement the nuclear reaction data obtained through experimentation, and standard nuclear reaction models for nuclear transmutation will be constructed. A nuclear reaction database will also be compiled and simulations will be performed for system development.
- ④ **Evaluation of nuclear transmutation system and development of elemental technologies**
- ⑤ **Process concept for design:** Long-Lived Fission Product (LLFP) such as long half-life nuclides will be recovered from high-level radioactive wastes and wastes

vitrified in glass and the concepts for the process of using nuclear transmutation to convert these into stable nuclides or short half-life ones will be researched.

In promoting this program, the most critical project will be Project ④. This project will be conducted in coordination with the other projects and will involve everything from scientific discovery to engineering development. Following the conclusion of the program, a pilot plant will be used to pursue development with the goal of implementation in society. In the future, the targets will be expanded to nuclides that were not included in the program. Another key point is the fact that the transmutation of the nuclides included in high-level radioactive waste and wastes vitrified in glass in Project ⑤ will also be considered.

Ultra-high Speed Multiplexed Sensing System Beyond Evolution for the Detection of Extremely Small Quantities of Substances

Use of nanoelectronics to achieve the extraordinary sensing systems acquired by insects through biological evolution

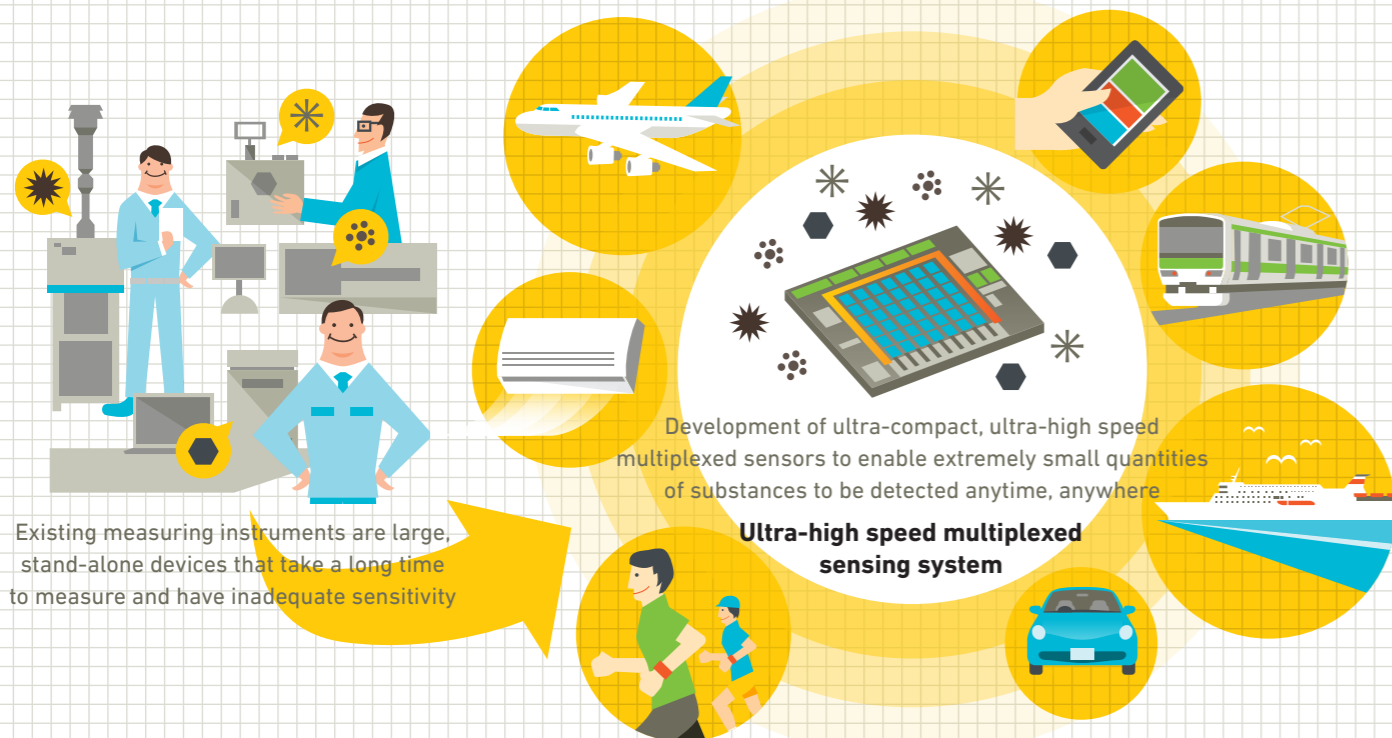

Existing measuring instruments are large, stand-alone devices that take a long time to measure and have inadequate sensitivity

Development of ultra-compact, ultra-high speed multiplexed sensors to enable extremely small quantities of substances to be detected anytime, anywhere

Ultra-high speed multiplexed sensing system

All around us, there are dangerous and hazardous substances such as bacteria, viruses, hazardous small molecules, PM2.5 particulate matter, and etc.. To ensure that everyone is able to live a healthy and comfortable life, this program will learn from the outstanding biological capabilities of insects and other creatures and develop an ultra-high speed multiplexed sensing system that surpasses these capabilities by use of nanoelectronics technology which is a Japan's strength. Installing this system in smartphones, household appliances, automobiles, eyeglasses, wristwatches and other products will make it possible to sense even minute quantities of dangerous and hazardous substances — anytime, anywhere. This will achieve the world's safest, most secure and most comfortable society and will also lead to the creation of a next-generation electronics industry.

Message

The development of "an ultra-high speed multiplexed sensing system beyond evolution for the detection of extremely small quantities of substances," will provide the world's most comfortable living environment and a healthy and comfortable lifestyle for all. These are important issues facing society, and its achievement is a goal that I consider to be my life's work. I believe this problem can only be solved by high-impact disruptive innovation. Now that we are able to realize this extremely important mission, we will energetically promote interdisciplinary cooperation and collaboration among industry, academia and government to achieve a safer and more secure society.

Program Manager

Reiko MIYATA
宮田 令子

- 1982 Graduated from Ochanomizu University
- Entered Toray Industries (Basic Research Laboratories)
- 2000 Ph. D. (Kyoto University)
- 2001 Senior Researcher at Toray
- 2004 IP manager at Nagoya University (on external assignment from Toray)
- 2010 Specially-appointed professor at the Nagoya Univ.
- Office of Industry Liaison
- 2014 ImPACT Program Manager

Creation of an ultra-high speed multiplexed sensing system that surpasses the capabilities of insects

Sensors that are capable of detecting extremely small quantities of substances are large apparatuses that take a long time to conduct measurements. They also have many problems in terms of performance, such as inadequate sensitivity and difficulty in measuring multiple items at the same time or performing qualitative and quantitative measurements simultaneously. This program will resolve these problems by learning from the astonishing biological capabilities of insects gained through the process of biological evolution. For example, in their tiny antenna and sensoria the size of which is only a few millimeters, insects have amazing sensing capabilities that enable them to detect substances with ultra-high sensitivity and distinguish from among tens of thousands of substances.

If an ultra-high speed multiplexed sensing system with capabilities that surpass those of

insects can be created, it would enable people to predict and prevent danger anytime, anywhere. This program comprises four objectives:

- Simultaneous measurement of bacteria and viruses that include WHO certified biological weapons, at a detection sensitivity of 1 particle and detection speed of 5 minutes
- Simultaneous qualitative and quantitative measurement of PM2.5 particulate matter, at a detection sensitivity of 1 particle and detection speed of 5 minutes
- Simultaneous qualitative and quantitative measurement of hazardous small molecules, at a detection sensitivity of 1 particle and detection speed of 5 minutes
- Multiplexed simultaneous measurement & monitoring and compact design

In the process from prototyping to commercial development of the new device, it will be necessary to overcome technical barriers

involving basic principles in terms of advanced microfabrication processing and electronics. This will require the active use of not only microfabrication facilities at universities but also corporate and public facilities, and at the same time research and development for future mass production will need to be pursued.

Furthermore, as a mechanism for implementation in society, the development of compact devices that can be mounted in smartphones, eyeglasses, wristwatches and other wearable devices, household appliances, vehicles and so on will be needed prior to the conclusion of the program. When processes are front-loaded in accordance with the progress of research and development, the development costs will be concentrated to enable product embodiment prior to the conclusion of the program.

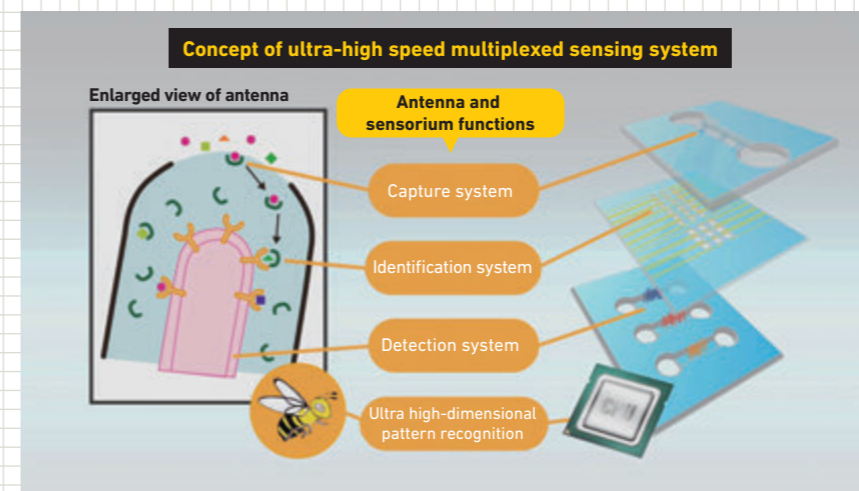

Ultra-high speed multiplexed sensing system

Insects have amazing sensing capabilities in their antennae and sensoria that enable them to detect substances with ultra-high sensitivity and distinguish among tens of thousands of substances. To achieve artificial antennae, the fundamental technology for capturing, distinguishing and detecting minute quantities of substances in the atmosphere must be developed. To achieve artificial sensoria, ultra-high dimensional pattern recognition technology for identifying and quantifying substances from the detected data must be developed. Based on this technical development, technologies for integration into ultra-compact devices will be established to create and market an ultra-high speed multiplexed sensing system.

Ubiquitous presence in the community and the home and use of "big data" systems will cultivate a 100 trillion yen industry

In order to achieve this program, the following three projects targeting different substances and a project to achieve international standardization and evaluation of the elemental technologies to be developed will be established.

- Project ①: Bacteria, viruses**
- Project ②: Hazardous small molecules**
- Project ③: PM2.5**
- Project ④: International standardization and evaluation**

The common issues to be focused on in Projects ① - ③ are:

- Trapping of substances from the atmosphere and concentration
- Size, shape and number measurement on the single particle and single molecule level
- Identification of molecules through high-dimensional pattern recognition

- Integration, modularization and prototyping for mass production and commercialization
 - Development of multi-item devices
- Prototypes that resolve two or more of these issues will be manufactured on a step-by-step basis. Ultimately, a new prototype device that integrates multiple items will be manufactured and verified. In Project ④, ISO and other international standardization will be pursued, and institutions capable of evaluation will be designated separately.

The research and development organization will explore multiple potential technologies on an exploratory basis and, by means of a competitive process, will narrow down the technologies within one to two years, in order to compare the competing technologies and determine which one has overwhelming superiority. At the stage where the technology has taken shape to some degree, a competition will be held to select a manufacturer to

implement the technology in a new multi-item device in order to create a tangible product. Performance milestones will be established at specific stages, and the plan-do-check-act (PDCA) cycle will be implemented on a quarterly basis to check the progress of each research institution and enable schedule management.

In the future, the role model for a next-generation electronics industry will be established to create an industry that is highly competitive internationally. In terms of application development, devices will be installed in communities and in homes and so on, and the creation of a "big data" system for the devices and other projects will be promoted to develop a 100 trillion yen next-generation industry.

Innovative Visualization Technology to Lead to Creation of a New Growth Industry

Establish an innovative 3D imaging method, with combination of cutting-edge laser and ultrasound to visualize invisible portions

Contribute to a healthier, safe and secure life through the visualization technology that realizes <Non-destructive> <Noninvasive> and <Painless>.

Application to food field

Application to medical field

Application to industrial field

With the arrival of the super-aging society, there has been a rapid increase in morbidity and the number of persons requiring nursing care, and there is widespread concern in the general public regarding illness and nursing care. In this situation, there is a need to enable people to continue working while preserving their health and beauty. There is also heightened concern about food safety, product quality and other issues, and achieving safety and security in people's lives is an important issue facing society. The goal of this program is to develop real-time 3D visualization technology that can image blood vessels to enable early diagnosis of disease, preventive medicine and maintenance of health and beauty. This visualization technology will contribute to extending "healthy life expectancy". In addition, by imaging of changes in physical properties in products and its materials, this technology will contribute to increasing the reliability of products, structures and food safety and improving the quality of Japanese products, thereby helping to strengthen competitiveness.

Message

The program is to conduct basic research, system development and application development (ranging from medical, healthcare, cosmetic fields to an industrial inspection field) on imaging technologies. Researchers in different fields, different industries will work together to create new industries in this program, which is without parallel in the rest of the world. We will focus our passion and work to ensure that as many people as possible are able to benefit from the achievements of the program in areas close to home.



Program Manager

P M

Takayuki YAGI
八木 隆行

- 1983 Received master's degree from Graduate School of Interdisciplinary Science and Engineering, Tokyo Institute of Technology
- Joined Canon Inc.
- 2005 Senior General Manager, Chief of Canon Research Center, Canon Inc.
- 2008 Senior General Manager, Medical Imaging Project, Corporate R&D, Canon Inc.
- 2014 ~ ImPACT Program Manager

Technological Approach

Achievement of real-time 3D imaging and Creation of new values

The photoacoustic effect is that sound waves are emitted in an object, illuminated with light. We apply this effect to imaging, "Photoacoustic imaging". When an object is illuminated with light pulses from a laser, the ultrasound waves are emitted from the absorber, received simultaneously by multiple ultrasound sensors and used to form a 3D image.

Photoacoustic imaging combines the high resolution of "Optical imaging" with the deep penetration of "Ultrasound imaging", making it possible to visualize clear images of locations deep inside the object. Matching the laser wavelength to the optical characteristics of the absorbers makes it possible to select each absorber to be visualized.

The goal of this program is to develop the technologies for real-time 3D visualization of blood vessels in the human body and the physical properties of substances, and then demonstrate the value of application in medical, healthcare, cosmetic and industrial inspection fields. To that end, the following four approaches will be studied.

Approach ①: Visualization of human tissue / substance

- Measurement technologies that enable visualization of the blood vessels and human tissues in the human body and the physical properties of the interior of objects will be developed.
- A high-energy pulse laser that generates light wavelengths adapted to the optical characteristics of human tissues in the human body and substances in objects will be developed.

Approach ②: High resolution and real-time ultrasound detection

- The frequencies of the ultrasound waves are inversely proportion to the target sizes. Ultrasound sensors that can receive various frequencies from various sized targets will be developed.
- Multichannel ultrasound sensor array that enable to receive ultrasound waves will be developed in order to form 3D image in real-time

Approach ③: Real-time 3D imaging

- High-speed signal processing, 3D reconstruction and 3D image processing technologies that are capable of imaging the enormous quantities of 3D data detected by ultrasound sensor array will be developed.

• A prototype of real-time 3D visualization system that demonstrates value in the medical and healthcare fields will be developed.

Approach ④: Demonstration of value

- The clinical value of blood vessel imaging in diagnosing cardiovascular disease, cancer and arthritis and assessment of therapeutic effect and so on will be demonstrated by using a prototype. In addition, image analysis to find diagnostic and evaluation indexes for judging the progress of disease and the therapeutic effect will be researched. This will lead to computer aided diagnoses and to medical and healthcare services that anyone can use at home for health management and health promotion.
- The ability to visualize internal imperfections, deterioration etc. in quality inspections, non-destructive testing and other industrial inspections will be demonstrated.

Image of blood vessels in the hand by the state-of-the-art photoacoustic imaging technology.

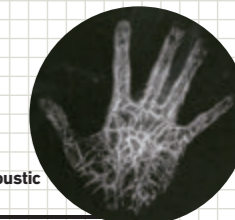

Principle of photoacoustic imaging

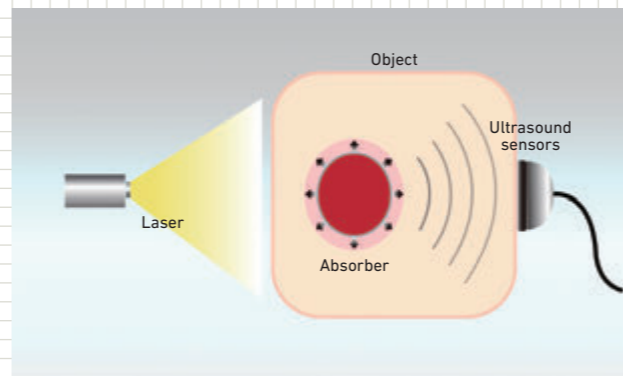

Combination of laser and ultrasound technologies

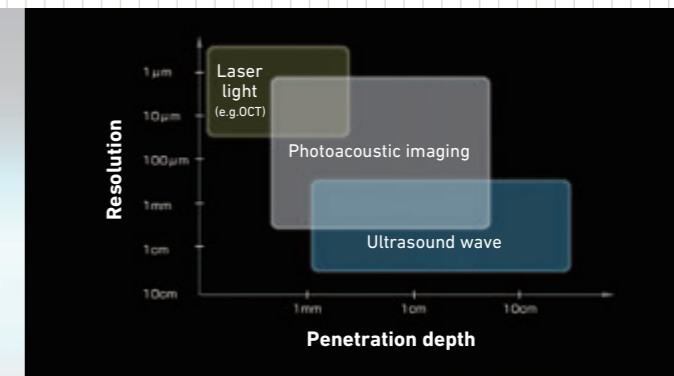

Program Configuration

To develop common and base technologies, visualization systems and demonstrate value for real-time 3D imaging

The overall configuration of the program consists of six projects: "Visualization technology", "Tunable laser technology" and "Ultrasound sensor technology" which are common base technologies for various industrial applications in; "Wide-field visualization system" and "Micro-visualization system" for the achievement of real-time 3D visualization; and "Demonstration of value" for creating the value of the new visualization technologies. Research institutions that possess global top-level technologies and companies that can develop commercial applications will work together on the research issues that must be resolved.

① Visualization technology project

High resolution imaging will be researched, analyzing the generating mechanism of photoacoustic signals and making a database of properties.

② Tunable laser technology project

Tunable lasers with ultra-wide range of wavelength, infrared tunable laser (700-1300 nm for measurement of human tissues) and a range of mid-infrared tunable laser (2 - 10 μm for measurement of substances), will be developed and achieved with high energy and compact. Achievement of maintenance-free design (an issue with a conventional high-energy pulse laser) and mounting on a visualization system.

③ Ultrasound sensor technology project

A sensor that can achieve ultra-broadband capacity will be developed through competition between a piezoelectric ultrasound sensor and a capacitive ultrasound sensor (CMUT). A 2D ultrasound sensor array designed for real-time detection will be achieved.

④ Wide-field visualization system project

High-speed signal processing, image reconstruction and 3D image processing

technologies for real-time will be completed and a 3D visualization system with high-resolution will be developed. The system can image blood vessels and blood condition in the human body.

⑤ Micro-visualization system project

A basic system will be designed based on high-frequency ultrasound technology and a micro visualization system will be developed. The system can image capillary vessels and blood condition in the skin.

⑥ Demonstration of value project

Clinical research trials in various diagnosis and treatment departments and multiple medical institutions will be performed to develop new diagnostic methods and physical function evaluation methods of vascular imaging. Diagnostic and evaluation indexes will be shown through image analysis, and a risk prediction model of disease will be proposed through "big data" analysis.

Actualize Energetic Life by Creating Brain Information Industries

Linking of research and development into brain information visualization and control technologies to social issues to create world-first brain information industries

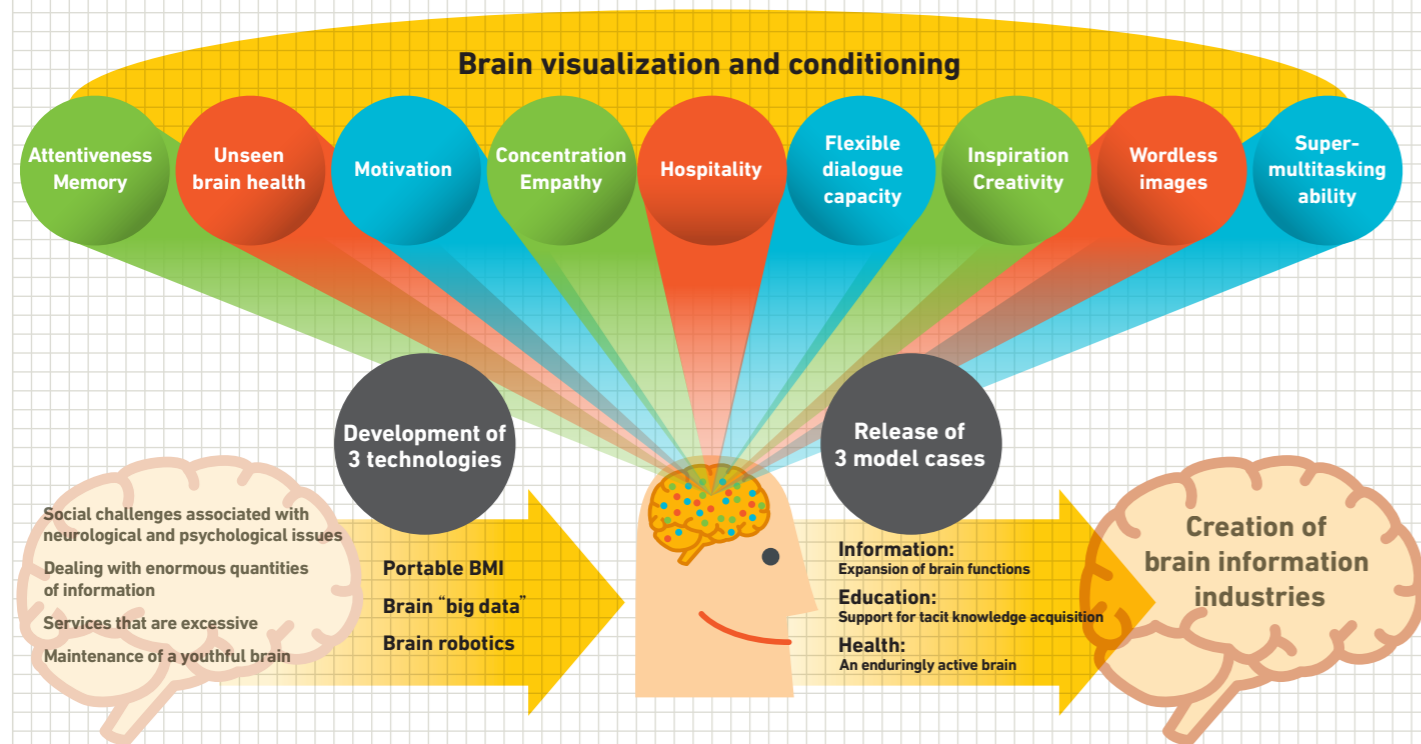

Almost all of the unresolved social challenges that we face today are associated with neurological and psychological issues. These include the need for information technologies that can communicate user's feelings in an information society, acquisition of professional expertise needed in a service economy, the prevention of a decline in brain functions in a rapidly aging society and so on. Needed are innovative efforts to use neuroscience to link the visualization of brain information and research into control technologies to the resolution of social issues. This program will make service models for brain information in the three sectors of health, education and information science publicly available. The construction of an innovation ecosystem through the creation of a brain information infrastructure will create the world's first brain information industries and achieve energetic lifestyles.

Message

In an increasingly information-oriented and service-oriented society, many problems are associated with neurological and psychological ones: the inability to achieve resonance with customer's true needs, the inability to deal with enormous quantities of information and so on. This ImPACT program will develop technologies to visualize brain status and adjust it to the brain status when one was young or that of the specialist one wants to become. This will enable model scenarios for achieving an enduringly active brain, support for tacit knowledge acquisition, and expansion of brain functions, in order to achieve the creation of world-first brain information industries.



Program Manager

P M

Yoshinori YAMAKAWA
山川 義徳

- 2000 M.S., Graduate School of Science, Kyoto University
- 2000 - 2005 NEC Corporation
- 2008 Received Ph.D. from the Graduate School of Human and Environmental Studies, Kyoto University (Human and Environmental Studies)
- 2008 - 2010 GCOE Assistant Professor, Graduate School of Informatics, Kyoto University
- 2010 ~ Director, Neuro Innovation Unit, NTT Data Institute of Management Consulting, Inc.
- Part-time instructor, Graduate School of Management, Kyoto University
- Part-time instructor, Research Institute for Economics & Business Administration, Kobe University
- 2014 ~ ImPACT Program Manager

Creation of innovation through "Portable BMI" "Brain 'Big Data'" and "Brain Robotics"

Continual advances are being made in current research into visualization and control of brain information. For example, large functional magnetic resonance imaging (fMRI) systems for the treatment of mental illness are being developed for commercial use. However, the mainstream methods for brain measurement involve the use of large, expensive equipment, and there is a tradeoff between cost and precision. The goal of this program is to develop a simple, portable brain machine interface (BMI) that enables visualization and control. Progress has also been made in the development of brain information decoding equipment that is designed for commercial use as well. As it will be important to expand the targets of brain information use and apply the benefits to the physical body as well, research into brain "big data" and brain robotics technology will also be promoted. Based on

these three technologies, the goal will be to reduce the cost of brain information use to 1/10 and increase performance tenfold. Proposed model cases for three service domains (health, education and information) will be clearly established for the three technologies in the program (portable BMI, brain "big data" and brain robotics), and a modular research and development approach will be used for implementation in society. For example, in the health domain, the goal will be to achieve "an enduringly active brain," and "maintenance and improvement of memory and concentration," "understanding diverse health conditions of the brain" and "support for healthy living of the brain and body (using robotics technologies)" will be proposed. In the education domain, the goal will be to provide "support for tacit knowledge acquisition," and "emotional and sympathy training," "sharing the

brain of professionals, such as that of hospitality pros" and "robotics to accelerate learning" will be proposed as models. In the information services domain, the goal will be an "expansion of brain functions," and "acquisition of imagination and innovativeness (inspiration)" "Diverse expression of information that transcends language" and "expanded physical capacity that evolves the brain" will be established as models. In addition to these projects, the establishment and maintenance of a brain information infrastructure that encourages the use of brain information, such as common clouds, common fields, standardization and the study of ethics and so on, will also be promoted. Collaboration between industry and academia and venture company support will also be pursued to cultivate the soil (innovation ecosystem) for the creation of innovation using brain information.

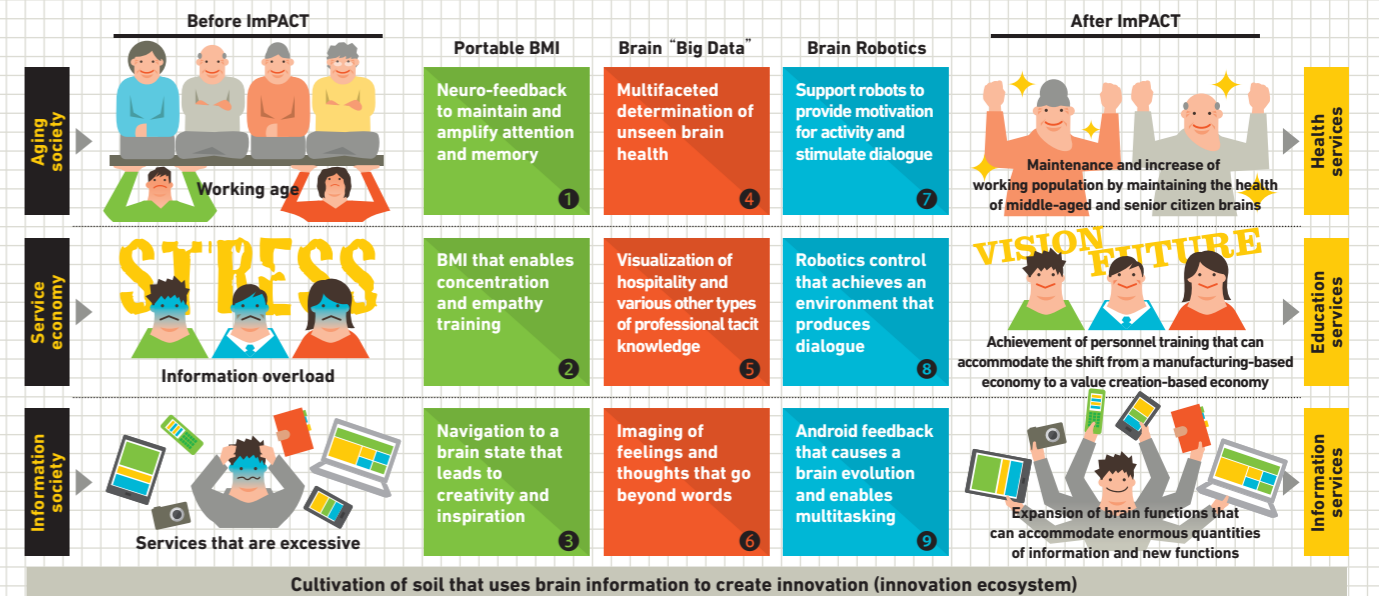

R&D Team Organization / Management and Research Promotion / Future Prospects

Projects for nine clearly established model cases for the use of brain information

The research and development organization will be led by the PM and three general technology officers, who will oversee neuroscience projects with a view to the "exit" (the changes in the state of industry and society that are envisioned by the ImPACT program). A modular group structure will be used for nine projects comprising three main technologies (Portable BMI, brain "big data" and brain robotics) in three main service domains (health, education and information).

Portable BMI

- ① **Portable BMI x health:** BMI technology will be developed to provide feedback for desired brain states to develop and provide services for a machine learning brain information promotion system that prevents and restores the decline in brain functions in middle-aged people and senior citizens.
- ② **Portable BMI x education:** technologies for quantitative analysis of information in real space to develop services that promote learning through environmental control in accordance with people's emotional state.

③ **Portable BMI x information:** technologies that use high-density optical brain function measurement to monitor states that are conducive to creativity and innovation will be developed in addition to prototyping and service provision.

Brain "Big Data"

- ④ **Brain "big data" x health:** automatic analysis technologies for brain information that can make a multifaceted determination of brain health will be developed. Field demonstrations will be conducted for the purposes of prototyping and advancement, and brain health visualization services will be provided.
- ⑤ **Brain "big data" x education:** brain information from specialists in a variety of areas will be compiled to visualize implicit knowledge. Prototype development and field demonstrations based on the results will be conducted to provide services to teach implicit knowledge.
- ⑥ **Brain "big data" x information:** technologies to decode various kinds of mental information to support design evaluations and marketing

activities will be developed. Ultimately the brain and the Internet will be linked to provide services that share images that go beyond words.

Brain Robotics

- ⑦ **Brain robotics x health:** with the objective of maintaining the mental and physical health of middle-aged persons and senior citizens, robots will be developed to support continued movement that would be difficult for the person to accomplish alone and to help stimulate dialogue.
- ⑧ **Brain robotics x education:** with the aim of improving work efficiency and communication in a variety of workplaces, effectiveness will be verified through hormone inspections, and humanoid media robots and robotics technologies that can enable environmental control will be developed.
- ⑨ **Brain robotics x information:** with the aim of expanding multitasking capability that makes it possible to process enormous amounts of information, systems will be developed to use androids to provide neuro-feedback in order to cause the brain itself to evolve.

Advanced Information Society Infrastructure Linking Quantum Artificial Brains in Quantum Network

Bringing neural network based information processing to quantum computing

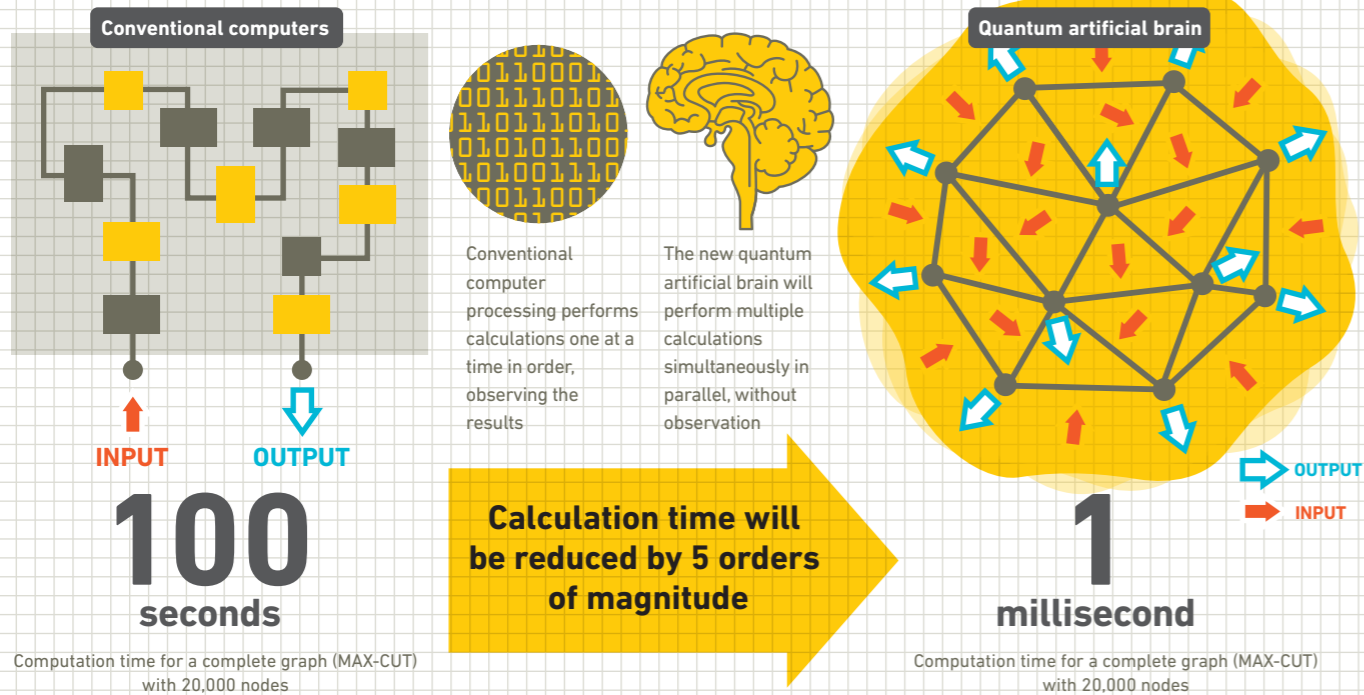

Combinatorial optimization problems are seen in various fields of modern society. For today's supercomputers to find solutions by brute force search from an immense number of combinations takes too long, and not all combinations can be processed. And so instead of giving exact solutions, they give approximations. This program will develop a new type of coherent computer (Ising machine) specializing in combinatorial optimization problems. This miraculous computer functions as a quantum artificial brain linked with a quantum network.

Message

The parametron computer using an electrical parametric oscillator was invented in Japan in 1954, and was developed by various Japanese electronics manufacturers. However, since its operating speed was lower than that of transistors and it consumed a lot of power, it was fated to disappear. Now, 60 years later, it's time for the quantum artificial brain to make its return. By replacing electricity with light and the classical logic circuit with a quantum network, and by deploying brain-like information processing, we will attempt to replace modern computers.



Program Manager

Yoshihisa YAMAMOTO
 山本 喜久

- 1973 B. S. from Tokyo Institute of Technology
- 1978 Ph.D from the University of Tokyo
- 1978 - 1992 NTT (presently R&D Fellow)
- 1992 - 2014 Professor, Stanford University (currently Professor Emeritus)
- 2009 - 2014 Core Researcher, First Program of Cabinet Office, Japan
- 2003 - 2014 Professor, National Institute of Informatics (currently Professor Emeritus)
- 2013 - 2014 Group Director, RIKEN
- 2014 ~ ImPACT Program Manager

Develop a unique quantum artificial brain based on a laser network system

Quantum computers bring the principles of quantum mechanics to computers. Current quantum computers are broadly divided into two types. One is the conventional quantum gate type comprising operation circuits that combine quantum bits representing 0s and 1s. The other is the quantum simulator. This maps mathematical problems (combinatorial optimization problems and so on) on physical phenomenon generated by a test device that simulates magnets under quantum effects, and outputs the results.

There are a further two types of quantum simulator. One is the quantum annealing type used by the D-Wave quantum computer recently employed by Google and NASA. The other is the coherent Ising machine advocated by Yamamoto PM on this program. This is something comprising a three-dimensional Ising model using optical parametric oscillators, fiber lasers, quantum measurement feedback circuits and so on.

A single photon can be modulated by its polarization of right/left spin (rotation). In addition, a single photon can be in innumerable different places at the same time. Therefore by making a single photon exist simultaneously in N different locations and changing the polarization of the photon, it is possible to express numerous different states. When calculations are performed simultaneously, the answers can be obtained instantaneously, unlike the old brute force calculations. If you input a problem to the quantum measurement feedback circuit and oscillate the laser, the laser light changes to match the circuit, outputting optimal oscillating light (the solution) to the problem at high speed. (If you heat up a coherent Ising machine from a negative temperature, at a certain point the laser oscillates, changing the spin sequence towards minimization of energy. The configuration shows the solution to the combinatorial optimization problem).

This program will develop a quantum artificial brain incorporating neural network based information processing using the principles of this sort of coherent Ising machine (computer). From one to one million individual light pulses emitted simultaneously by a fiber parametric oscillator are regarded as neurons, which are interconnected in a quantum measurement feedback circuit to realize a synapse network. Combinatorial optimization problems are mapped using the synapse reversibility of the quantum feedback circuit.

The program will also develop a quantum secure network that cannot be tapped by any means, and a quantum simulator that is better at large scale scientific calculation than modern computers.

Conceptual diagram of the quantum artificial brain

The quantum artificial brain is a system that brings brain-like information processing to quantum computers. Using by optical fibers, optical signals emitted by a transmitter are likened to brain neurons that govern the information processing of the brain. We will combine these with integrated circuits that can process the information. In this way, we will realize a synapse network using quanta.

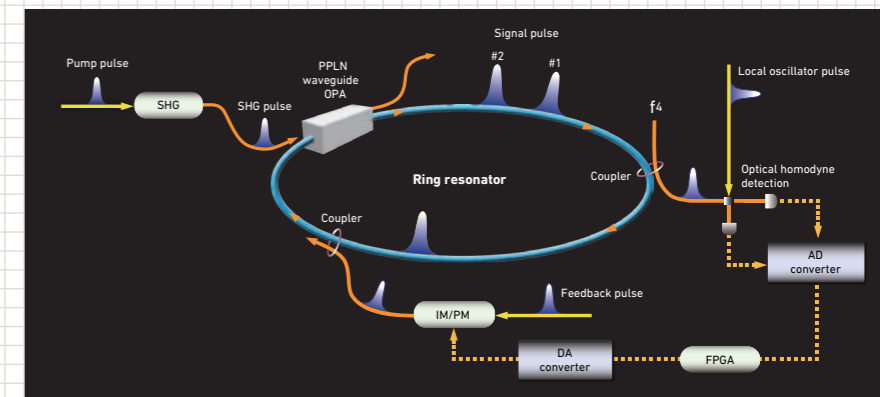

Establishment of an advanced information infrastructure combining quantum artificial brains and quantum secure networks

This program will address the three development targets of a quantum artificial brain, quantum simulation, and quantum secure networks through the following projects.

Quantum artificial brain

Develop a quantum artificial brain with 5,000 to 10,000 neurons and 100 million synapse connections, and validate its applicability to combinatorial optimization problems.

- 1 **General review:** Proceed maintaining a good balance of quantum artificial brain theory and hardware and software development
- 2 **Brain-type information processing:** Aim to improve the performance of coherent Ising machines by introducing branching theory associated with Optical Parametric Oscillation (OPO) phase transition and a synapse reversibility model
- 3 **Optical fiber OPO development:** Development of a large scale optical fiber OPO device comprising PPLN waveguide devices and optical fibers

Optical fiber laser development:

Development of a multiplex pulse mode synchronization optical fiber laser device

5 **Development of quantum measurement feedback circuits:** Develop a FPGA circuit for controlling optical fiber OPO devices. If these can be connected to a multiplex pulse fiber parametric oscillator, the quantum artificial brain hardware can be realized.

Quantum secure network

The quantum secure network project comprises the following four projects; 1 **Basic design and globalization technologies.** 2 **Quantum key distribution system and application interface (API).** 3 **Multiple value modulation concealment transmission technologies.** 4 **Development of new theories.** In this way, we will build quantum secure networks in urban areas with safety and high interconnectivity that cannot be decrypted even with future computer technology, and achieve services for latent users.

Quantum simulation

Set up the following five projects: 1 **Strongly correlated quantum simulation theory.** 2 **Quantum simulator development.** 3 **Non-equilibrium open quantum simulation theory.** 4 **Non-equilibrium open quantum simulation testing.** 5 **Discovery of new quantum simulation approaches.** By simultaneously developing and comparing quantum simulators using cold atoms, superconducting quantum circuits, and semiconductor devices, demonstrate their superiority in relation to large scale scientific calculations using modern computers.

Small Synthetic Aperture Radar Satellite System for On-Demand Observation

A new approach of SAR design, "Deployable and Passive Slot Array Antenna System" to realize the world's lightest and small SAR satellite system.

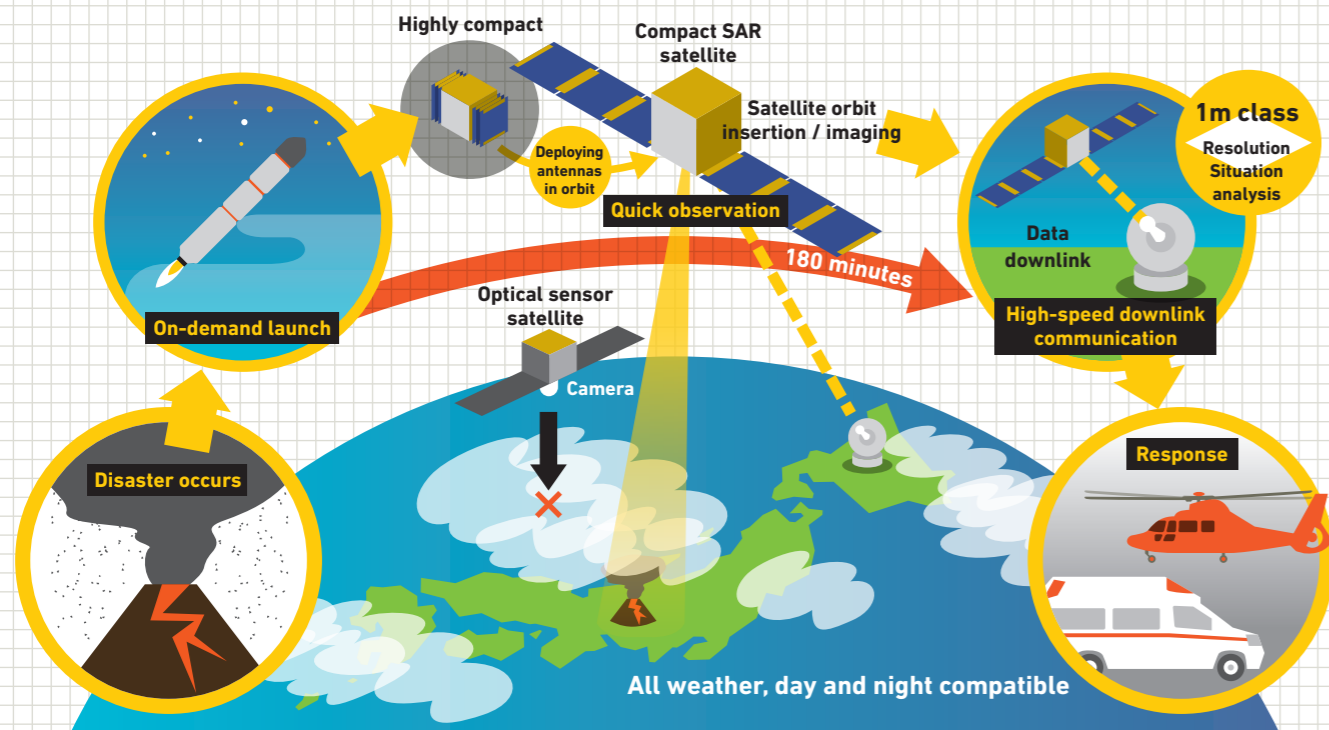

During emergency situations such as a natural or man-made disaster, rapid responses by social infrastructure are essential in order to minimize damage. "24 hours responsibility under all-weather condition", "quick response", "responsibility for wide area disaster" and "simultaneous observation capability for surrounding region" are surely required for the satellite observation system to be beneficial as reliable social infrastructure. This program develops Small Synthetic Aperture Radar (SAR) satellite system capable of on-demand launching and quick observation. The new approach of SAR design "Deployable and Passive Slot Array Antenna System" is selected in this program and it realizes an ultra-lightweight and highly compact, 100kg-class, satellite system with 1m-class spatial resolution SAR sensor. Considering future business prospects, the mass production cost around 2 billion yen is targeted in this program, which will be one-tenth of conventional systems. Our aimed system enables "all-time and all-point observation" in whole world several ten minutes to several hours after launching under all condition, even at night and under rainy/cloudy/stormy weather.

Message

Developing artificial satellite technology that "shocks the world" to create a next-generation "Vital Eye", that provides peace of mind. That is the objective of this program. Our satellite system that enables a paradigm shift from the conventional approach of using satellites already in orbit based on the timing of their availability to the new approach of "on-demand observation" to launch satellites into the desired orbit at the desired time. A small synthetic aperture radar system under strict limitations to enable global monitoring even in bad weather and at night. We will conduct the R&D to achieve these goals simultaneously.



Program Manager

P M

Seiko SHIRASAKA
白坂 成功

- 1994 Masters of Engineering from Graduate School of Engineering, the University of Tokyo
- 2012 Ph. D. in Systems Engineering from Graduate School of System Design and Management, Keio University
- 1994~2010 Mitsubishi Electric Corporation Kamakura Works
- 2000~2002 EADS Astrium (present name: Airbus) Exchange Engineer
- 2010~ Associate Professor, Graduate School of System Design and Management, Keio University
- 2015~ ImPACT Program Manager

Lightweight, Highly Compactible System Achieved through a Passive Flat Surface Deploying Antenna that Expands into a Dual-Wing System in Orbit

Synthetic Aperture Radar (SAR) is a technology to create a virtual large aperture antenna by repeating signal transmitting and receiving by an antenna installed on a flying object, such as satellite, along the course of the object's movement. SAR is an active sensor that transmits microwaves (X/S/C/L band, etc.) and receives the reflected waves from ground surface. The feature has advantage of no visibility degradation by bad weather (cloud) and night (no daylight).

X-band SAR system normally requires heavy satellite weight, more than 1 ton, and huge manufacturing cost, over 10 billion yen, so far. To enable on-demand satellite launch under emergency situations requires not only making use of solid-fuel rocket, which does not need fueling just before launching, but also achieving drastic reduction of size and weight for the

actual satellite design and manufacturing.

This program adopt new approach of SAR design "Deployable and Passive Slot Array Antenna System" which differs from mainstream of SAR design, such as Active Phased Array Systems and Parabolic Antenna System, to aim unprecedented minimal satellite size and weight.

In our system, total 7 honeycomb panels of slot array antenna, which realize very small structure volume in folding state, are installed on earth direction side of the satellite body. As for antenna deployment hinge, choke flange of low-loss feeding with non-contact waveguide is used. Thin-film solar cells to generate solar power will be put on the reverse side of the antennas. The transmitter is equipped with a solid-state high power amplifier comprised of highly efficient gallium nitride (GaN) amplifier

and RF combiner with waveguide resonator.

To achieve a system weight of 100kg-class, this program use the experienced small satellite bus of HODOYOSHI program as baseline architecture and additionally develop key bus technologies (power system, thermal control system and so).

Furthermore, fully autonomous onboard processing function of Earth observation including self-troubleshooting after insertion into orbit is incorporated in order to respond on-demand request. The outcome of the HODOYOSHI program is applied to the data communication system to achieve the world's fastest data transmission performance (1.5Gbps and faster) capable of downlinking the observation data of a scene in single pass.

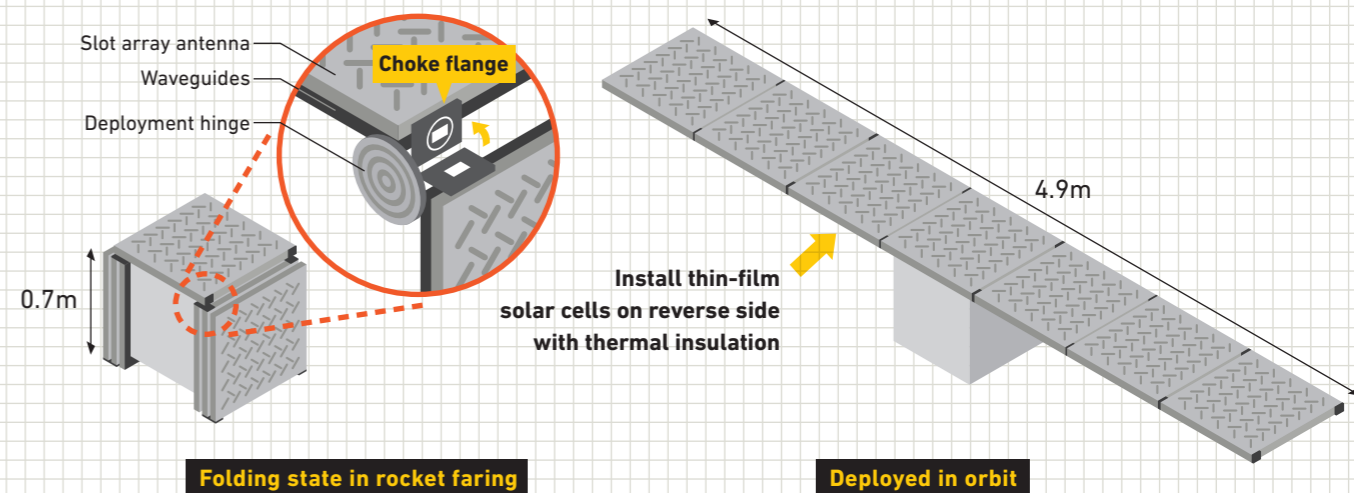

Three Projects to Achieve a Satellite System to Provide a Vital Eye in Emergency Situations

This program will be comprised of the following three projects.

① Satellite System Project: This project will conduct R&D toward the creation of on-demand (automated and autonomous) functions that enables quick observation; the development of new technology required for a satellite bus equipped with these functions and a small SAR, and the validation of the developed technologies on the ground. As for the bus equipment to have research value necessary to accomplish SAR system, the design-validation units are developed. Numerical simulation will be utilized to validate the on-demand function on the ground. As for the high-speed data communications needed to achieve on-demand performance, ground-based validation will be conducted and flight-based validation will be aimed.

② SAR System Project: This project conducts R&D toward the realization of ultra-lightweight and highly

compact small SAR system fulfilling with the required functions and performance. Furthermore, the SAR component units capable of in-orbit operation are developed to conduct the validation and the testing of the system on the ground.

③ Integrated System Project: This project will conduct the research to design the integrated system including the small SAR satellite system, ground systems and assumed users and to develop the evaluation system to validate the feasibility.

These three projects are deeply interconnected. The SAR system developed through the SAR System Project will be combined with the satellite bus developed through the Satellite System Project to form a single satellite. The automated and autonomous functions of the satellite bus have a deep correlation with the ground systems and rockets that will be researched during the Integrated Systems Project. Also, the observed data recorded by the

SAR will be downlinked and used by the ground system.

As such, close partnerships between these three projects will be vital to this program.

This program will provide a form of social infrastructure that will serve as a vital eye in emergency situations, such as responses to natural disasters, to support minimize losses and quick responses. This system will contribute to safety and security in the world. This program will also create business opportunities to the regional observation of areas with high rates of cloud coverage, the use of real-time big data of observation data and the enhancement of international competitiveness through the export of equipment sales and small SAR satellites systems.

Artificial Cell Reactor Technology for an Enriched and Secure Society and New Bioengineering

Technological innovation using artificial cell reactors can resolve fundamental issues facing the bioanalysis industry and bioindustries that use enzymes and cells

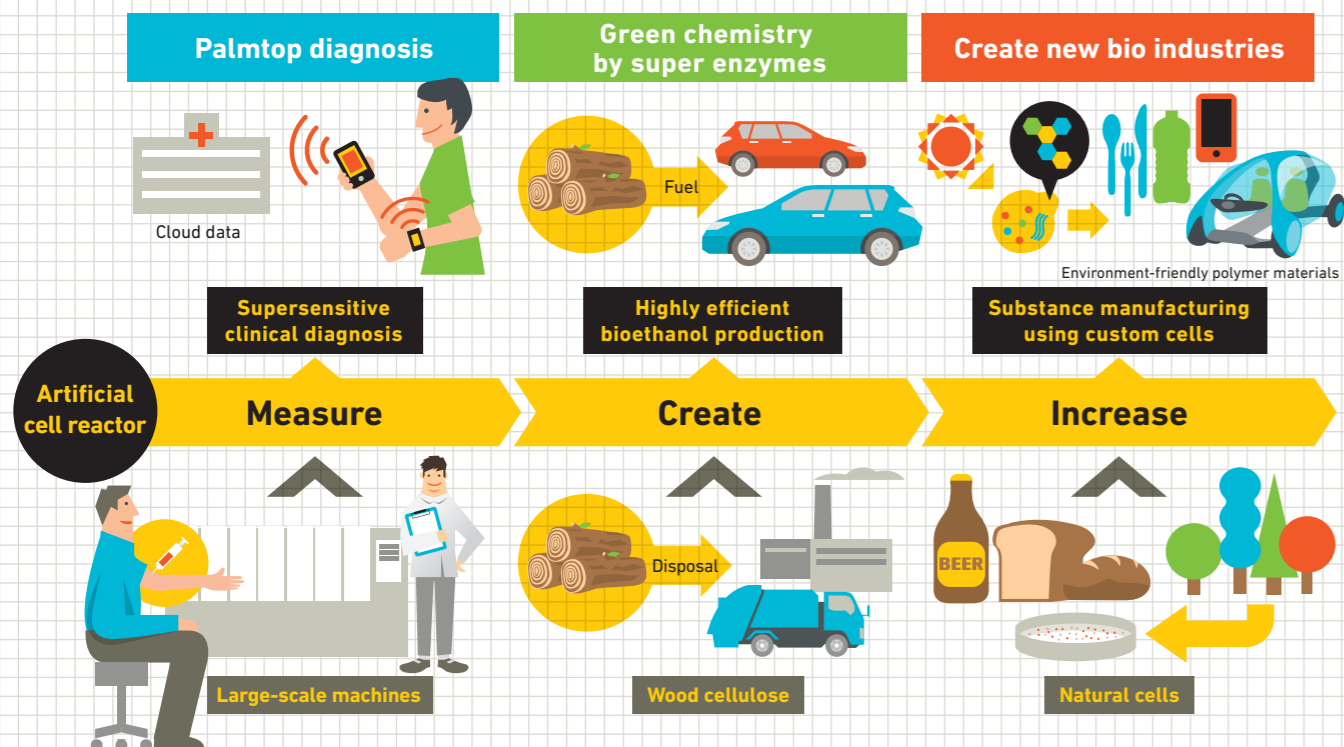

The bio industry field is expected to see massive growth. However, today the field still requires fundamental technology innovation. For example, in the agriculture, forestry, and fishing industries are in need of simple, accurate genetic testing methods and supersensitive detection to prevent pandemic spread of infectious diseases. Preventative medicine is in need of supersensitive detection of disease markers to detect and monitor the progression of severe diseases such as cancer and Alzheimer's disease. And, bioengineering field requires technology for the rapid development of super enzymes that outperform natural enzymes and technology for synthesizing custom-designed artificial cells for industrial use. Through this project, we will achieve discontinuous innovation with an artificial cell reactor that enables new bioengineering. Specifically, we will advance development in three stages (Measure, Create, and Proliferate) based on the degree of molecular integration and purpose. We will create compact, supersensitive diagnosis systems, super enzymes capable of high-speed biomass processing, and bio technology based on artificial cells capable of auto-reproduction. We will then present society with practical applications for these technologies.

Message

The prototype artificial cell reactor developed ten years ago for fundamental research will serve as the foundation of this program. Since then, the applied research using this technology has had much more of a profound response than expected and I have been involved in collaborative joint research with private companies. What I learned from this experience is that the results of fundamental research grounded in free thought can directly lead to social innovation. This project will effectively link artificial cell reactor research and talented researchers in relevant fields from Japan and around the globe with business world to create entirely new innovations.



Program Manager

P M

Hiroyuki NOJI
野地 博行

- 1997 Received Doctor of Science from Tokyo Institute of Technology
- 1998 JST CREST Doctoral Research Fellow
- 2000 JST PRESTO Researcher
- 2001 Assistant Professor, Institute of Industrial Science, University of Tokyo
- 2005 Professor, Institute of Scientific and Industrial Research, University of Osaka
- 2010 ~ 2015 ~ Professor, Graduate School of Engineering, University of Tokyo
- 2015 ~ ImPACT Program Manager

A three-phase approach based on the degree of molecular integration and purpose to challenge ourselves to innovative bioengineering!

This program will advance development gradually in three stages (Measure, Create, and Proliferate) based on the degree of molecular integration and purpose to achieve new bioengineering based on artificial cell reactor technology.

In the "Measure" step, we will use an artificial cell reactor with the volume of femtoliters (10⁻¹⁵ liters) to conduct the various types of bioanalysis used in clinical diagnosis (gene detection, immune assay, etc). Artificial cell reactor enables single molecule detection by condensing reaction product molecules of bioanalysis reactions. Then, single molecule detection allows binarization of signal readout, drastically improving signal-to-ratio. We also will develop a low-cost, compact device small

enough to fit in the palm of your hand that will achieve an on-site diagnosis and be cloud enabled. There are no existing examples of technology that achieves all three of these performances.

The "Proliferate" step will exploit the massively parallel nature of artificial cell reactors to produce numerous types of genetic materials (≠ enzymes). This array will be used for innovative screening technology to explore super enzymes with significantly enhanced functions. This technology will, for example, create super enzymes that are far superior to natural enzymes in reaction rate. These rate-enhanced super enzymes will solidify the super sensitive diagnosis technology developed in the "Measure" step.

In the "Proliferate" step, we will integrate in-tube reconstitution technology of genome replication reaction with artificial cell reactor technology to achieve one-pot genome synthesis in a few hours and create artificial cells capable of self-replication (activated by artificial genomes). There are several reports of artificial genome synthesis and artificial cell creation. However, these have yet to reach the stage of social innovation. This is because genome synthesis requires massive funding and time, and because cells are limited to a specific bacterium. Through this program, we will resolve such issues.

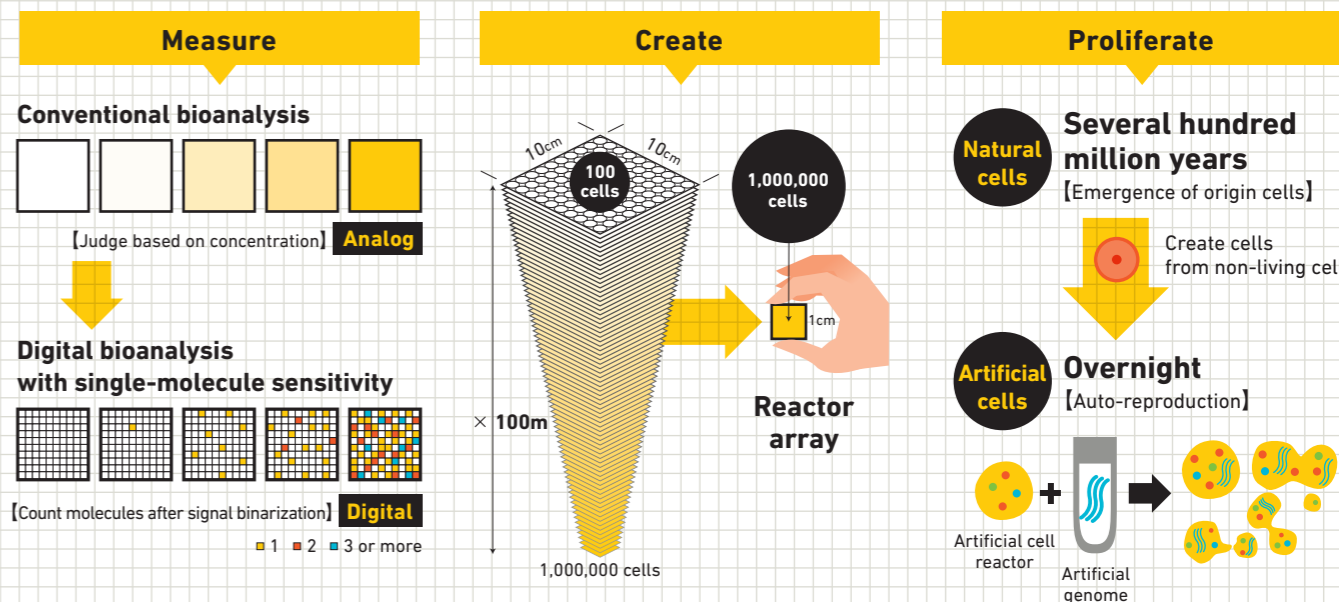

Artificial genome and cell technology will lead to innovation in all aspects of bio industry!

This program will be advanced based on the formation of an industry-academia cluster of researchers working in the field of artificial cell reactors. As the same types of artificial cell reactor will be utilized among research projects of this program, we will establish a shared foundry that consolidates expensive fabrication machines to efficiently produce artificial cell reactor devices. We also will consolidate infrastructures for advanced microscope systems for the measurement of the devices with fabrication machines. For this purpose, a fundamental technology support group responsible for both device fabrication and hardware development will be established at the University of Tokyo. Grounded on this fundamental technology support, this program will be comprised of three artificial cell reactor projects: Measure, Create, and Proliferate.

1 Measure: Artificial Cell Reactor Project
We will develop a "single molecule digital ELISA"

that achieves sensitivity 100 times greater than the most advanced instruments currently used in clinical diagnosis. We will also establish a highly versatile digital gene analysis method based on an "isothermal digital DNA assay" that is simpler and faster than PCR (Polymerase Chain Reaction). In addition, we will develop novel digital bioassays. We will also explore novel molecular markers to further expand diagnosis market.

2 Create: Artificial Cell Reactor Project
In addition to screening using an array-type artificial cell reactor equipped with gene expression functions and membrane protein screening using liposome sorting technology, we will explore novel techniques comparable to both these methods. We also will develop the fluorescent indicators required for screening as well as work on library creation technology that is optimized for these novel-screening techniques for the development of highly active, super enzymes.

3 Proliferate: Artificial Cell Reactor Project
This project will focus on the establishment of the in-tube synthesis of artificial genomes and technology to boot up artificial genome. For boot-up technology, we will launch projects of cyborg bacteria or a liposome fusion technology based on a biohybrid devices. We will also publicly seek innovative idea from young researchers.

Once this project achieves the ultimate goal of establishing artificial genome and cell technology, it is sure to bring disruptive innovations to every field of bio-industry. At least, in the near-term, Japan can establish the core technology and position in the synthetic genome business, a field that is sure to grow in the future.

Bionic Humanoids Propelling New Industrial Revolution

Using "an elaborate fakes with sensors" to quantitatively understand qualitative sensory expressions and quickly provide society with various innovative technology seeds by eliminating trial and error

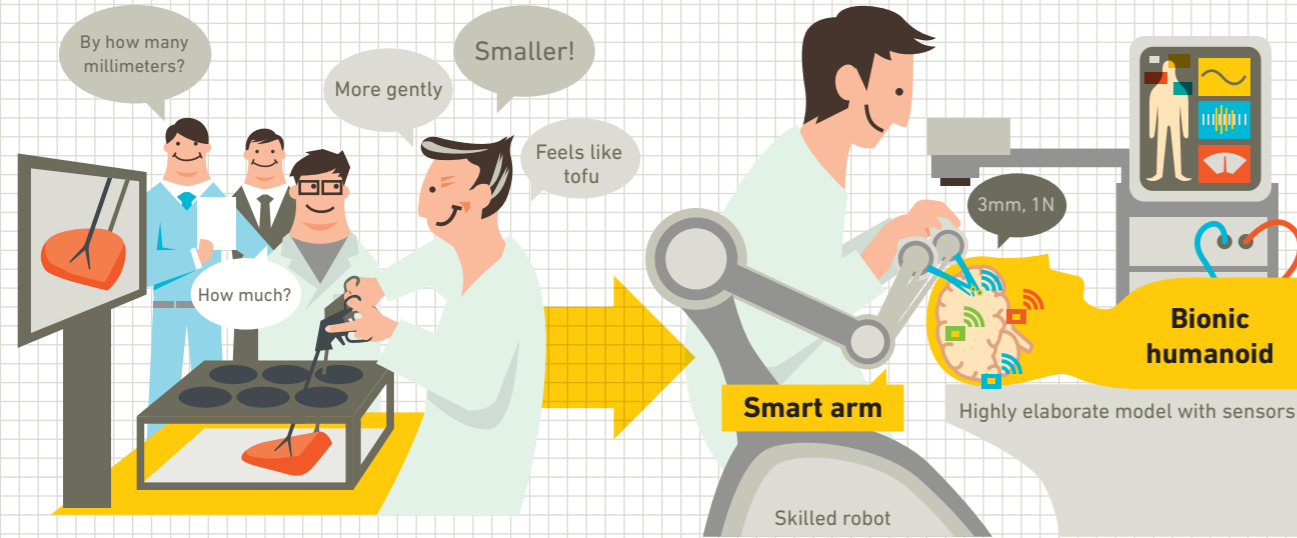

Qualitative

Quantitative

Qualitative sensory expressions are used widely in the R&D, evaluation, education, and training in the development of devices for humans, and significant trial and error is involved. The result is that it takes time for seeds for innovative technology to reach society. This program proposes to use "elaborate fakes equipped with sensors" to quantitatively understand qualitative sensory expressions and quickly deliver technology seeds to society by eliminating trial and error. The first target application is the medical field, and we will develop a bionic humanoid, an elaborate human model equipped with sensors to serve as a substitute for humans and test animals. This program will also achieve a medical revolution by developing a smart arm using robotic technology seeds to conduct precision surgeries from small openings. Expanding these results to other industries will lead to a new industrial revolution.

Message

The practice of "look and learn" is a common culture in the medical, welfare, manufacturing, and agricultural industries. There is a significant amount of trial and error, and the transfer of technology from one person to another is difficult. Also, technology development involves actual testing on humans and animals, making it impossible to ignore social and ethical issues. Changing this process is the challenge undertaken by this program. To create frameworks for quickly delivering various innovative technology seeds to society, this program will gather the world's top researchers to work toward the realization of this concept.



Program Manager

P M
Kanako HARADA
 原田 香奈子

- 2001 Received M.E. from Graduate School, The University of Tokyo
- 2001 - 2004 Hitachi Ltd.
- 2005 - 2007 Japan Association for the Advancement of Medical Equipment
- 2007 Received Ph. D. in Engineering from Graduate School, Waseda University
- 2007 - 2010 Postdoctoral Research Fellow, Scuola Superiore Sant'Anna, Italy
- 2010 - 2012 Project Assistant Professor, Graduate School of Engineering, The University of Tokyo
- 2012 ~ Project Lecturer, Graduate School, The University of Tokyo
- 2015 ~ ImPACT Program Manager
- 2016 ~ Associate Professor, Graduate School, The University of Tokyo

Challenge in the Medical Field

As an application for "elaborate fakes with sensors" in the medical field, first we will develop a bionic humanoid, an elaborate human model equipped with sensors. It is easy to envision a bionic humanoid if you conjure the image of the stiff human models found in a science room but with properties exactly like a human and equipped with internal sensors. For example, conventional education and training for endoscopic surgeries involves exercises using model organs in a box called a dry box and training based on the principle of learning by watching. Even for the engineers who want to provide devices it has been difficult to quantitatively understand the desires of physicians.

This program substitutes this dry box with a bionic humanoid. This enables quantitative understanding of qualitative sensory

expressions such as "bigger" or "feels like tofu", making the medical education and training more efficient and accelerating medicine-engineering collaborations. Also, experience surgeons will perform a mock surgery on bionic humanoids while the movements of and forces applied by the surgeons are recorded by internal sensors. Analysis of how surgical procedures were conducted from the perspective of the patient will distinguish between surgeon habits and skills, and identify techniques common to skilled surgeons.

Using bionic humanoids as a platform will accelerate various R&D, evaluations, education, and training, and promote more efficient medicine-engineering collaborations. As well as collaborations among industry, government, and academia. This program will also take on the challenge of achieving a medical revolution

through the use of robot technology as an example of social revolution using innovative technology seeds. The program will develop a "Smart Arm," an intelligent and skilled robot equipped with the extracted skills. Using the Smart Arm, the surgeon can perform safe and advanced microsurgery as if he or she is a skilled surgeon.

The broadbased development of a process revolution entailing the use of such "elaborate fakes with sensors" will spark new industrial revolutions. In addition to using bionic humanoids as a substitute for humans and animals, the base technology will be applied widely throughout industry. In particular, the approach of extracting skills from the perspective of "what was done to the object" will be applied broadly to industrial robot learning and control.



Medicine / Welfare / Manufacturing / Agriculture, etc. For example...

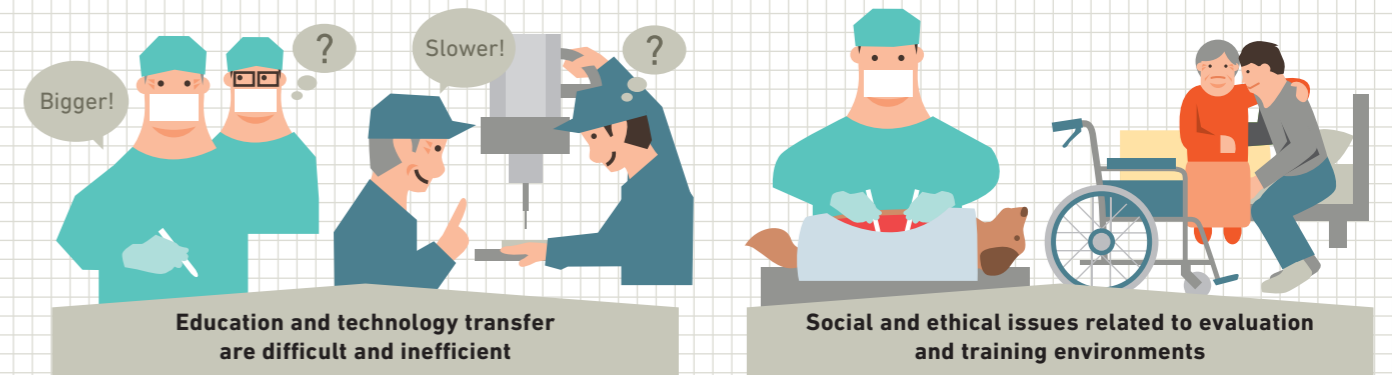

Gather top class researchers in the fields of measurement, processing, materials, and robotics to break through technological barriers

This program will start with projects focusing on medical applications, and then expand into other industrial sectors by adding beneficiaries via nominations and public calls. Initial projects will include the Bionic Humanoid Project, the Smart Arm Project, and Medical Field Application Project.

1 Bionic Humanoid Project: Medical image processing technologies will be studied to extract organs, membranes, and other detailed structures. Mechanical properties of organs, such as a required force to peel off a membrane, will be measured and quantified into reproducible characteristics. The project will also select the necessary materials, develop processing methods, and mount sensors. This program will create a bionic humanoid with a head model featuring particularly accurate reproductions of the brain and eyes.

2 Smart Arm Project: Creation of the Smart Arm, a skilled robot that combines arms, sensor-equipped tools, and user interface. Using an industrial robot for the arm will result in a project that ensures not only the application of advanced robotic technology in the medical field, but will also enable technology developed for the medical field to be applied in other industries. For the sensor-equipped tools, the project will aim to achieve repeated positioning with 10 μm-level accuracy for use on the brain and eyes, and develop a user interface that enables the intuitive control of complex movements of the tool tip. Skills extracted using the bionic humanoids will be implemented to the Smart Arm, which will feature controls that enable the safe and accurate handling of deformable tissue. Mock procedures will be performed on the bionic humanoids.

3 Medical Field Application Project: Developed bionic humanoids and the Smart Arm will be evaluated for their applicability in the medical field. The project also will collect medical images and biological samples to conduct analyses, including applications for Ethics Committee approvals.

4 Industrial applications: To promote application outside the medical field, projects targeting industries such as welfare, manufacturing, and agriculture will be launched based on nominations and public calls. This program will develop "elaborate fakes with sensors" and apply them towards R&D, evaluations, education, and training.

An Ultra Big Data Platform for Reducing Social Risks

Development of an ultra big data platform capable of ultra-high-speed analysis and ultra-wide-area data collection that far exceeds the scale of today's big data processing

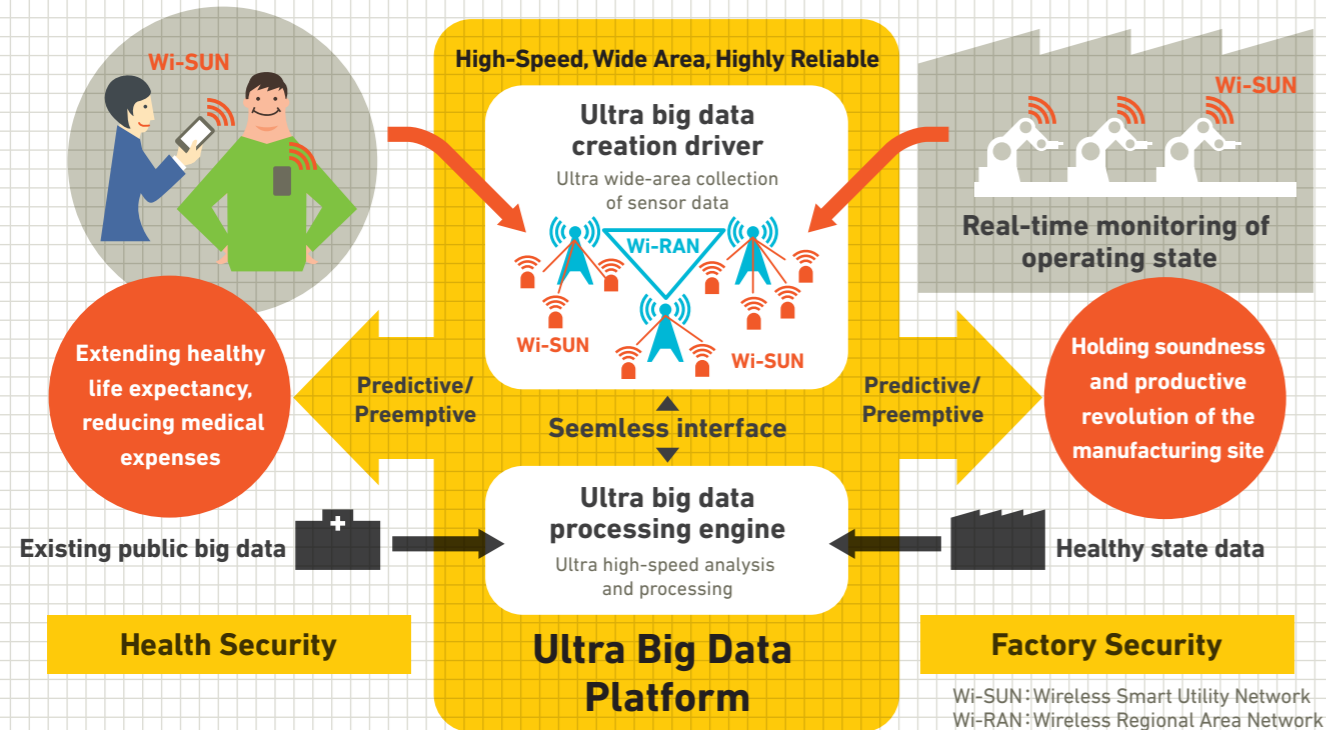

There are more than 100 billion network-ready sensor devices around the world but as of 2013 only a small percentage of these devices were actually connected and capable of sending data. More so, there is no existing platform capable of processing several 10's of billions of data records in several minutes. To address this, we will construct an ultra big data platform that far exceeds the scale of today's big data processing. Using this platform, we will use national and local public medical data and continuous measurement data to offer predictive and preemptive healthcare and medical services, through which we will achieve Health Security that helps extend healthy life expectancy and reduce medical costs. We also will aim to realize the social application of Factory Security, which will help eliminate cyberattacks on factories and improve productivity and profitability by safely connecting control devices in factories into groups of one thousand units.

Message

This program will bring together global research institutes in the fields of IT (information technology) and CT (communications technology), fields in which there is a lack of collaborative work, to realize a platform capable of generating ultra-big data and conducting ultra-high-speed processing and analysis. The global research institutes will conduct the ultra high-speed processing of non-continuous data at volumes never before achieved to realize a social risk estimation simulator for predictive and preemptive medicine and whose results can be reflected in policy. This program will further realize a factory simulator capable of the early detection of malfunctions and the high-speed elimination of cyberattacks at networked factories. I hope you will look forward to results achieved through the kind of multidisciplinary synergy that is unique to funding by the Cabinet Office.



Program Manager

P M
Hiroshi HARADA
 原田 博司

- 1995 Received Ph. D. from Osaka University Graduate School (engineering)
- Joined the Communications Research Lab of the Ministry of Posts and Telecommunications (Currently NICT)
- 1997-2009 Researcher, Delft University of Technology, The Netherlands
- 2009-2011 Vice-chairman, IEEE802.15.4g, The United States
- 2011 Director of the Smart Wireless Laboratory, NICT
- 2012- Founder and board co-chair of the Wi-SUN Alliance, The United States
- 2014- Professor, Graduate School of Informatics, Kyoto University
- 2015- ImPACT Program Manager

Economic Impact Worth Several Trillion Yen Achieved through the Early Realization of Strategic Applications!

Today, national and local medical institutions generate and accumulate public medical data records (macro data) numbering in the tens of billions on a yearly basis. However, the reality is that it would take weeks to analyze this data. At the same time there is no networked platform in existence capable of enabling the continuous measurement and automated cloud storage of vital data for thousands of people (micro data).

Also, the product factories supporting Japanese manufacturing require flexible production line designs and accurate production predictions that will enable factories to not only meet functionality and quality specifications, but also respond to the strict production parameters of their customers. There is an urgent need for connected factories.

This program will address such social needs by achieving the early realization of strategic applications such as Health Security (HS) using

ultra big public medical data and Factory Security (FS) using high-speed, large-volume real-time big data from factories. Through these applications, this program will aim to generate an economic effect on a scale from several hundred billion to several trillion yen.

The breakthrough required to achieve this is an Ultra Big Data Platform. This platform will be achieved by combining two major technologies, a big data processing engine (BDE) and a big data creation driver (BDD).

The development of a big data processing engine will involve developing a processing engine capable of ultra high-speed access in the realm of ten million times per second in order to process big data containing several tens of billions of records in a matter of minutes. We will aim to expand a non-order-type database to a cloud scale and achieve ultra high-speed analysis 100,000

times faster than conventional approaches. This switches the focus from the conventional method of enhancing the server (computer) side to a focus on a storage-centric (recordable media) solution.

For the ultra big data creation driver, we will build a communications environment consisting of an ultra high-performance wireless smart lifeline network (narrow area Wi-SUN (Wireless Smart Utility Network) system) that enables connections between several thousand terminals within a several kilometer area and an ultra wide area high performance wireless relay line network (wide area Wi-RAN (Wireless Regional Area Network) system) that covers several tens of kilometers. This will enable the collection of big data generated from tens of thousands of monitors and sensors dispersed over an area ranging in size from several kilometers to several tens of kilometers.

Macro data (public medical big data)

Ultra big complex data, national receipt data, DPC data, government death statistics tables, nursing care benefit cost survey, Comprehensive Survey of Living Conditions

Micro data (real-time measurement big data)

Temperature, physical information, electrocardiogram information, continuous blood pressure monitoring information, behavior & climate environment correlation information, regional medical treatment information

Healthy operating condition prediction data

When production plans are input, sequencer (PLC) assembly and processing machinery (robots) command flow is output

Real-time measure data from actual factories

Real-time collection of control commands generated each several 10ms from 100 to 1000 devices

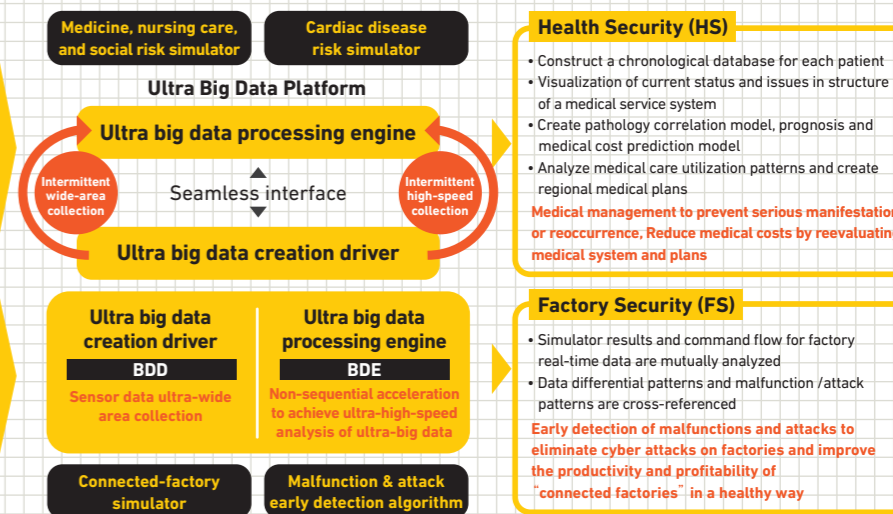

Structure for technology and application development supporting ultra big data platform

Japan's best big data specialists and world-class researchers will be brought together. During the first year of this lateral partnership, results will be consolidated and validated. This will be followed by the creation of standards, practical applications, and commercialization. This program will be comprised of the following four projects and an Implementation & Utility Project that fuses together the results of each individual project.

1 Ultra Big Data Creation Driver Project: Comprised of the "Narrow-area Wi-SUN System" and "Wide-area Wi-RAN System" teams. The former will use a distributed autonomous structure to develop a high-speed, efficient, smart wireless network that gathers data from monitors and sensors dispersed over an area several kilometers wide. The latter will be in charge of a multihop, ultra wide area, highly efficient wireless relay line network that connects this area over a range of several tens of kilometers. These will be used to gather and control several tens of billions of records

generated daily while maintaining high reliability and a high response speed (several 10ms).

2 Ultra Big Data Processing Engine Project: Based on the knowledge gained through the research results of an advanced R&D support program (the FIRST Program), this project will develop a non-order-type big data engine capable of analyzing the massive big data generated on a daily basis (several tens of billion records per year) within several minutes. This will be expanded to a cloud scale and implemented as an ultra high-speed processing engine.

3 Health Security (HS) Project: Comprised of teams that will develop simulators for "Medical, Nursing Care and Social Risks" and "Cardiac Disease Risks". The former will use tens of billions of public medical big data records intricately to build a chronological database according to medical subject type and to develop a simulator that conducts ultra high-precision macro estimates based on the individual, region, time, etc. The latter will develop a simulator that uses

continuous large-volume big data, such as blood pressure and weather data, acquired from sensors to make micro-level predictions concerning subject health risks. These will be combined to realize predictive and preemptive medical services.

4 Factory Security Project (FS): Comprised of the "Connected Factory Simulator" and "Malfunction/Attack Detection Algorithm" teams. The former will develop a simulator that outputs command flows to sequencer (PLC) assembly and processing machinery (robots) after a production plan is input. The latter will be in charge of a malfunction and attack early-detection algorithm that uses these results and real-time data from actual factories to improve factory health and productivity.

Validation and testing for the HS and FS will be implemented during the final year of the program with local government and domestic test factories, respectively.

The ImPACT mechanism

Impulsing
PAradigm
Change through disruptive
Technologies
Program

Budget

- Funds were prepared with 55 billion yen appropriated from the supplementary budget for fiscal year 2013
- ※ Positioned as part of the specific measures of the Economic Measures for Realization of Virtuous Cycles (approved by the Japanese Cabinet on December 5, 2013)
- ※ The period of establishment of the fund is until fiscal year 2018
- Act on the Japan Science and Technology Agency was partially revised to accommodate establishment of the fund.

Budget
¥55 BILLION
Supplementary budget for fiscal year 2013
Preparation of fund

Intellectual property and conflicts of interest

Intellectual property

- Article 19 of the Industrial Technology Enhancement Act applies.
- Where necessary, mutual use by research institutions participating in the R&D programs is permissible.
- Intellectual Property Management Body in each PM's program will discuss the requisite matters regarding management of intellectual property such as conditions for granting licenses and similar matters.

Conflicts of interest

- With regards to conflicts of interest between PMs and the institutions to which PMs are affiliated, appropriate judgments will be made with due consideration to the necessity, reasonableness and pertinence of the relationship in question.
- The Committee for Promotion of ImPACT Program will give approval in the event that the body to which a PM is affiliated is selected as a research institution, or the allotment of R&D funds is altered.

Promotion structure

The Committee for Promotion of ImPACT (the Committee)

- The Committee will decide the basic guidelines for the ImPACT programs
- R&D - When an institution affiliated with the PM or located outside Japan is to be selected as the R&D institution, the Committee will approve the selection.

The Panel of Experts on ImPACT (the Panel)

- The Panel will confirm the R&D institutions selected by the PM
- The Panel will receive reports on the status of program progress from all the PMs at approximately half-year intervals.
- The Panel members will provide appropriate advice and cooperation to PMs where necessary
- The Panel may require PMs to make improvements according to the presented progress reports

PM

Program Manager

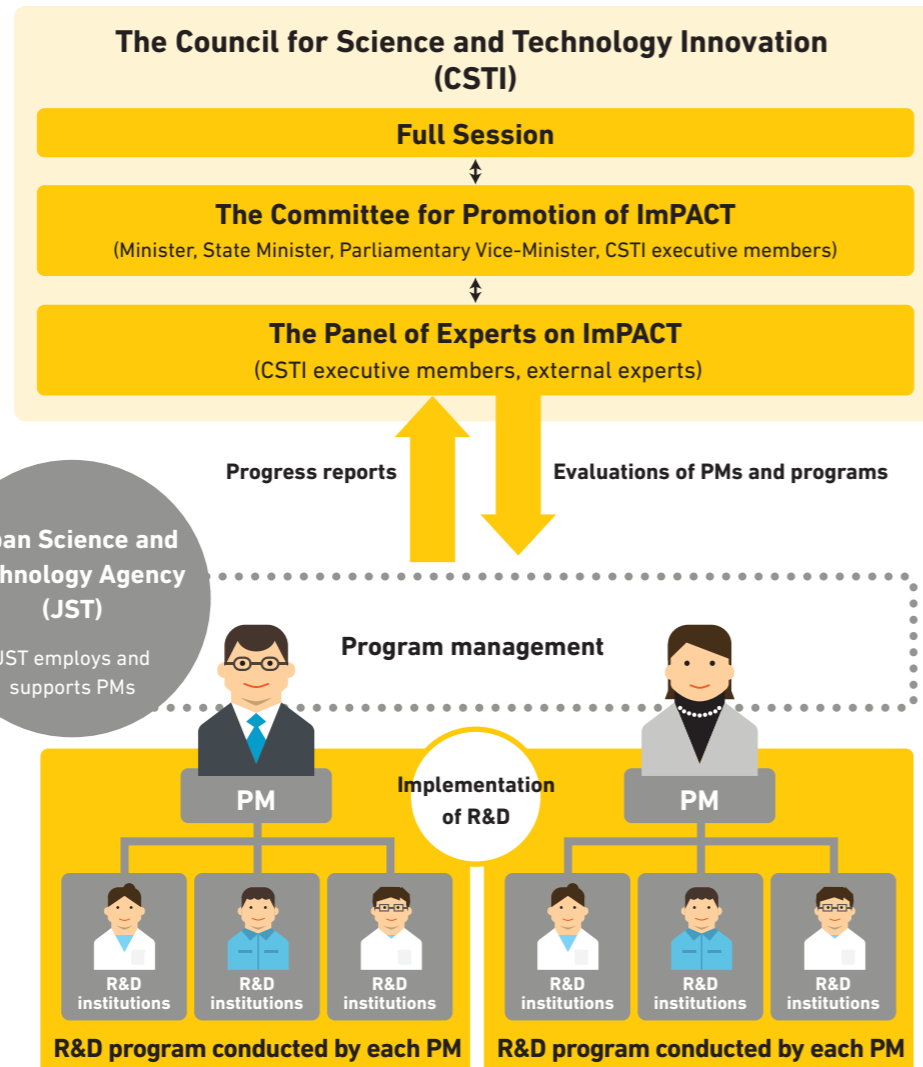

Creating “made-in-Japan” disruptive innovation through ImPACT

Under the leadership of the Prime Minister and the Minister of State for Science and Technology Policy, the Council for Science, Technology and Innovation (CSTI) has been planning and formulating comprehensive science, technology and innovation policies. ImPACT is one of these measures, and is a national prioritized project with the goal of creating disruptive innovation through ambitious R&D topics, thereby bringing about a revolutionary change to Japanese industry and society.

We have always insisted that there are two types of innovation: sustaining innovation and disruptive innovation. While sustainable innovation supports the further reinforcing of businesses and the sustainable improvement of their product value, disruptive innovation seeks to create robust new businesses accompanied by a paradigm shift.

Since disruptive innovation is difficult to achieve through the extension of the technologies we have developed thus far, the ongoing prolongation of existing R&D programs is also inadequate. This is why ImPACT has been designed and launched under the auspices of the centralized CSTI command structure, a ground-breaking program the likes of which has never been previously seen.

ImPACT has incorporated the project manager (PM) method, a new concept that has not previously been adopted in national projects. The PM is not a researcher but is more like a producer who sets high targets, chooses a cast of the very finest researchers and implements high-risk, high-impact R&D. We at CSTI will put our full weight of support behind our PMs and pursue the goals of ImPACT in total solidarity with them. We will create disruptive technology here in Japan. We will turn Japan into a nation brimming with the spirit to take on challenges. We expect great things from this program and we hope you do, too.

March 2015
Full-time Member of CSTI
Kazuo Kyuma

久間和生

Executive Members of CSTI

Full-time



Kazuo Kyuma
Former Senior Corporate Adviser, MITSUBISHI ELECTRIC CORPORATION



Yuko Harayama
Professor Emeritus, Tohoku University



Takahiro Ueyama
Vice President, National Graduate Institute for Policy Studies

Part-time



Takeshi Uchiyamada
Chairman of the board, Toyota Motor Corporation



Kazuhito Hashimoto
President, National Institute for Materials Science



Motoko Kotani
Director, Professor and Principal Investigator, Advanced Institute for Materials Research, & Mathematics Institute, Graduate School of Science Tohoku University



Masakazu Tokura
Representative Director & President, Sumitomo Chemical Co., Ltd.



Takashi Onishi
President of Science Council of Japan