

The next generation FrontEnd Controller for the Phase 1 Upgrade of the CMS Hadron Calorimeters

Francesco Costanza on behalf of the CMS Collaboration

Abstract: The ngFEC (next generation FrontEnd Controller) is the system responsible for slow and fast control within the Phase 1 Upgrade of the CMS Hadron Calorimeters. It is based on the FC7, a μ TCA compatible Advanced Mezzanine Card developed at CERN and built around the Xilinx Kintex[®]-7 FPGA. The ngFEC decodes the 40.0788 MHz LHC clock and the synchronization signals received from the backplane and distributes them to the frontend electronics using a GBT link. The latency of the fast control signals is fixed across power cycles and across identical ngFEC channels. Even if the direct link to a frontend module is broken, a redundancy scheme ensures a successful communication using the link to the neighboring frontend module. Thanks to the ngFEC all frontend modules can be remotely programmed through the JTAG standard. The CCM server software interfaces the ngFEC to the Detector Control System (DCS) which constantly monitors voltages and temperatures on the frontend electronics. This contribution reviews the characteristics and the development status of the ngFEC.

Introduction

The energy and luminosity upgrade of the Large Hadron Collider (LHC) and Compact Muon Solenoid (CMS) Detector requires improvements on the CMS electronic infrastructure as well. The CMS HCAL control system is planned to be upgraded by

- replacing VME standard to μ TCA which offers higher data transfer rates through the backplane, better cooling options, and power management configurations in a more compact crate;
- adding redundant control paths between the front-end crates;
- improving software and firmware features, reliability, and performance.

The next generation Front-End Control (ngFEC) crate connects and organizes the control path between the front-end modules and the CMS control systems. It also distributes the LHC clock (40.0788 MHz) to the front-end readout system.

ngFEC FC7

Each ngFEC FC7 is capable of controlling 6 HF (HB/HE) front-end modules each with 14 (12) I²C slaves. Each μ TCA crate can accommodate up to 12 ngFEC FC7s.

Slow control, JTAG, and ngFEC specific commands are received from the CCM Server through IPBUS protocol and stored in dual port BRAM blocks. The fast controls coming from TTC through the AMC13 are directly sent to the ngCCM.

The ngFEC crate communicates with the ngCCM via GBT protocol through the fiber connections. Each I²C master on the ngFEC FC7 controls one bit of the GBT word and all the masters are sharing the same I²C clock. Therefore, even though the data transfer rate is 4.8 Gbit/s, 100 KHz I²C communication can be maintained simultaneously and independently for each front-end I²C slave.

CCM Server and TTC

Crate Control Module (CCM) Server is developed at DESY. The CCM server configures/enables the front-end modules. It also reads the debugging and the sensor information (temperature, voltage, etc) from the front-end modules and drives the manual controls like reset signals.

The CCM Server forms slow control commands and sends them to ngFEC FC7 board through the IPBUS protocol.

Right now, the CCM Server provides a command line interface, and a GUI will be implemented in the future as well.

The central LHC clock and fast control signals are delivered by the **Timing Trigger Control (TTC)** system to the AMC13 board in the ngFEC crate. The AMC13, then, recovers the fast control signals and 40.0788 MHz LHC clock from the SFP connection and distributes them to the ngFEC FC7s.

Summary and Outlook

The ngFEC FC7 firmware can simultaneously drive slow controls to 14 (12) I²C slaves and fast controls for each of the 6 SFP links to HF (HB/HE) front-end modules. Furthermore, ngFEC FC7 can remotely program front-end FPGAs through JTAG commands. The system has been tested in three test stands (CERN, DESY, and FNAL), in dedicated irradiation tests performed at the CHARM facility, and with real proton-proton collisions at CMS. Installation is foreseen during LHC EYETS 2016/17.

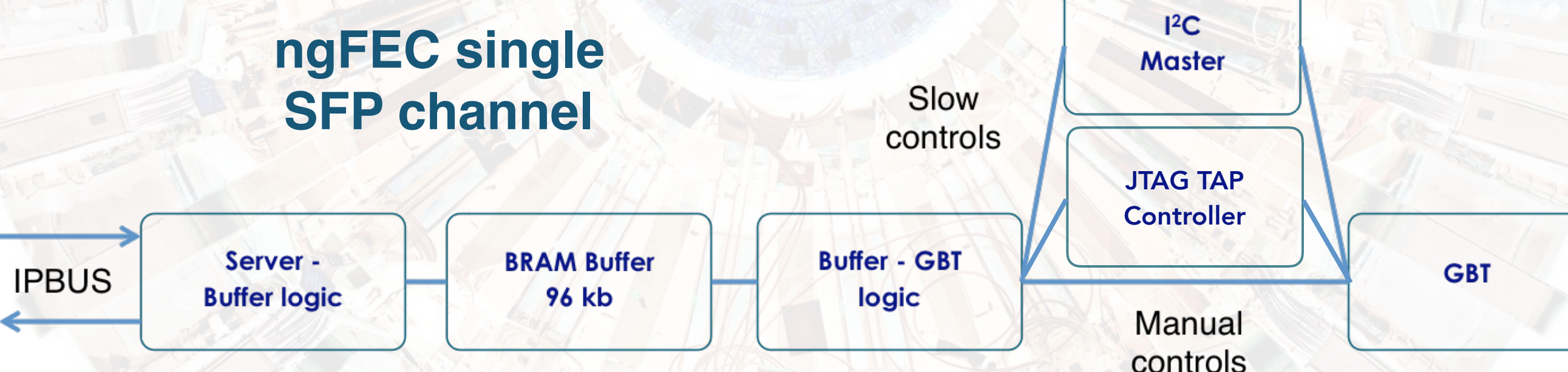
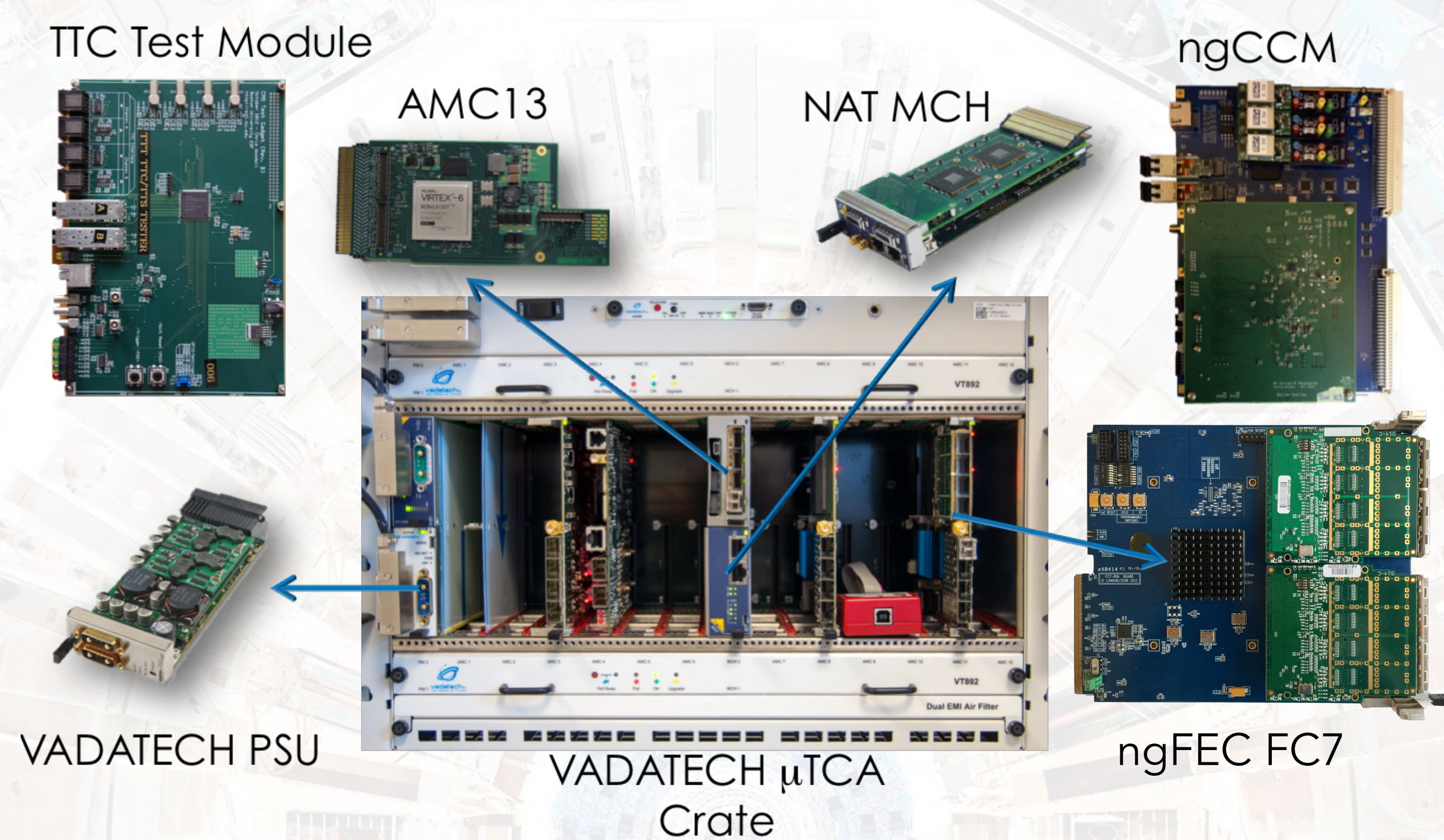
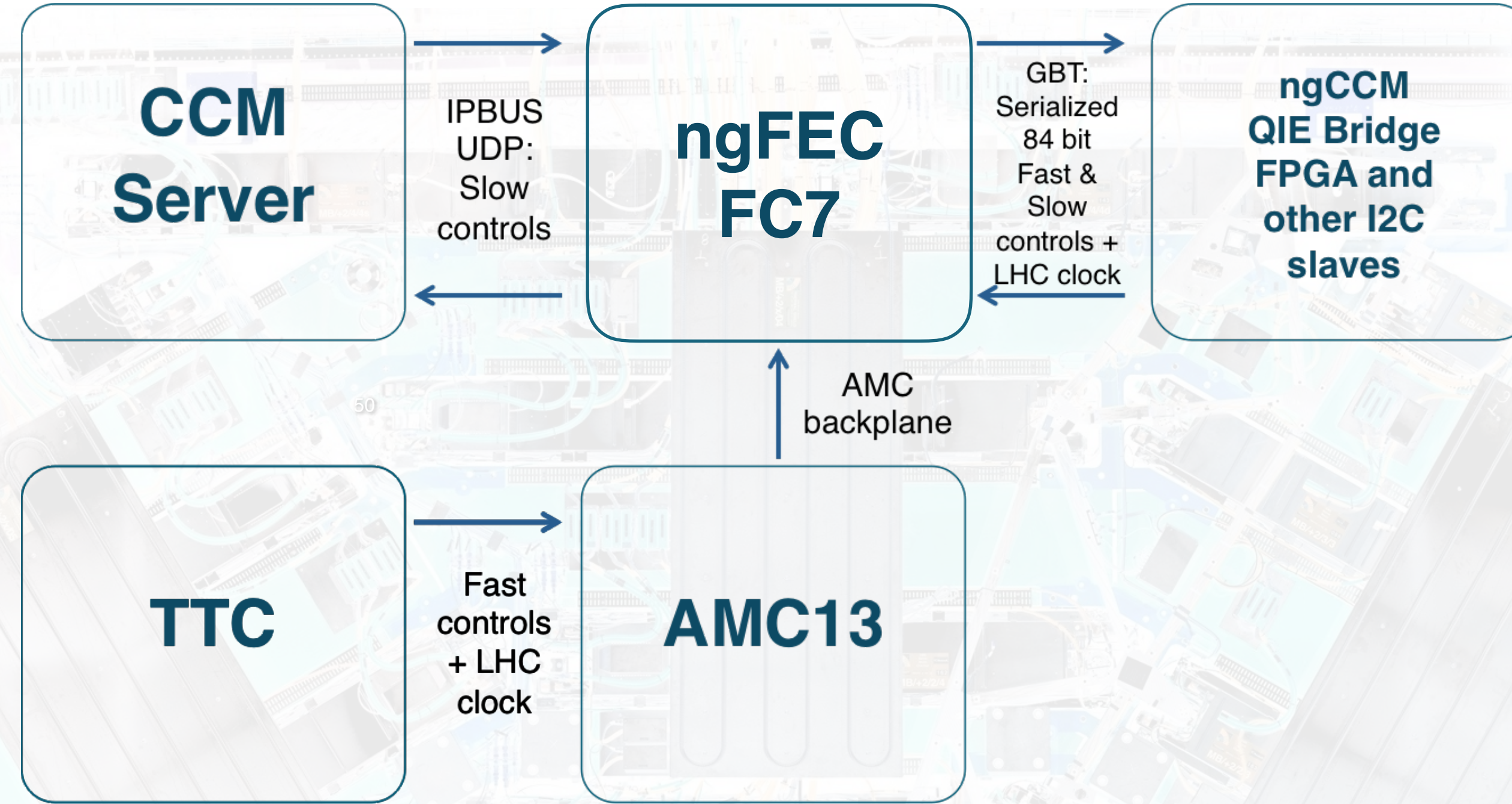

Front-End Electronics

The front-end modules are located next to/inside the CMS detector, hence they must be able to operate in a harsh radiation environment.

The ngCCM distributes the fast control commands, the LHC clock and the slow control commands to the front-end. An internal I²C slave sends temperature and status information to the CCM server.

The QIE boards carry a bridge FPGA which provides access to several components on the board (QIE, GBTx chips etc). An I²C slave implemented on the bridge FPGA with a custom scheme between the CCM Server and the bridge FPGA routes the slow control commands to other components by switching I²C lines. Therefore, the CCM Server effectively controls all the components on each QIE board with a single I²C link to the board.

Irradiation test at CHARM, CERN

An error detection module is designed in the FPGAs on both sides of the link using 23-bit Pseudo Random Binary Sequence (PRBS). The generated 23-bit PRBS patterns are included in the payload of the link in both directions. This module is employed to detect the errors that could not be corrected by the Reed-Solomon forward error correction algorithm, which is part of the GBT protocol.

Front-end modules were irradiated at the CHARM facility at CERN. CHARM uses 24 GeV protons from the PS to create a mixed radiation environment. Two different levels of radiation rate were investigated: the lower (higher) one is obtained colliding the PS beam on aluminum (copper) target.

The error cross section did not change neither with overall integrated fluence, nor with integrated dose.

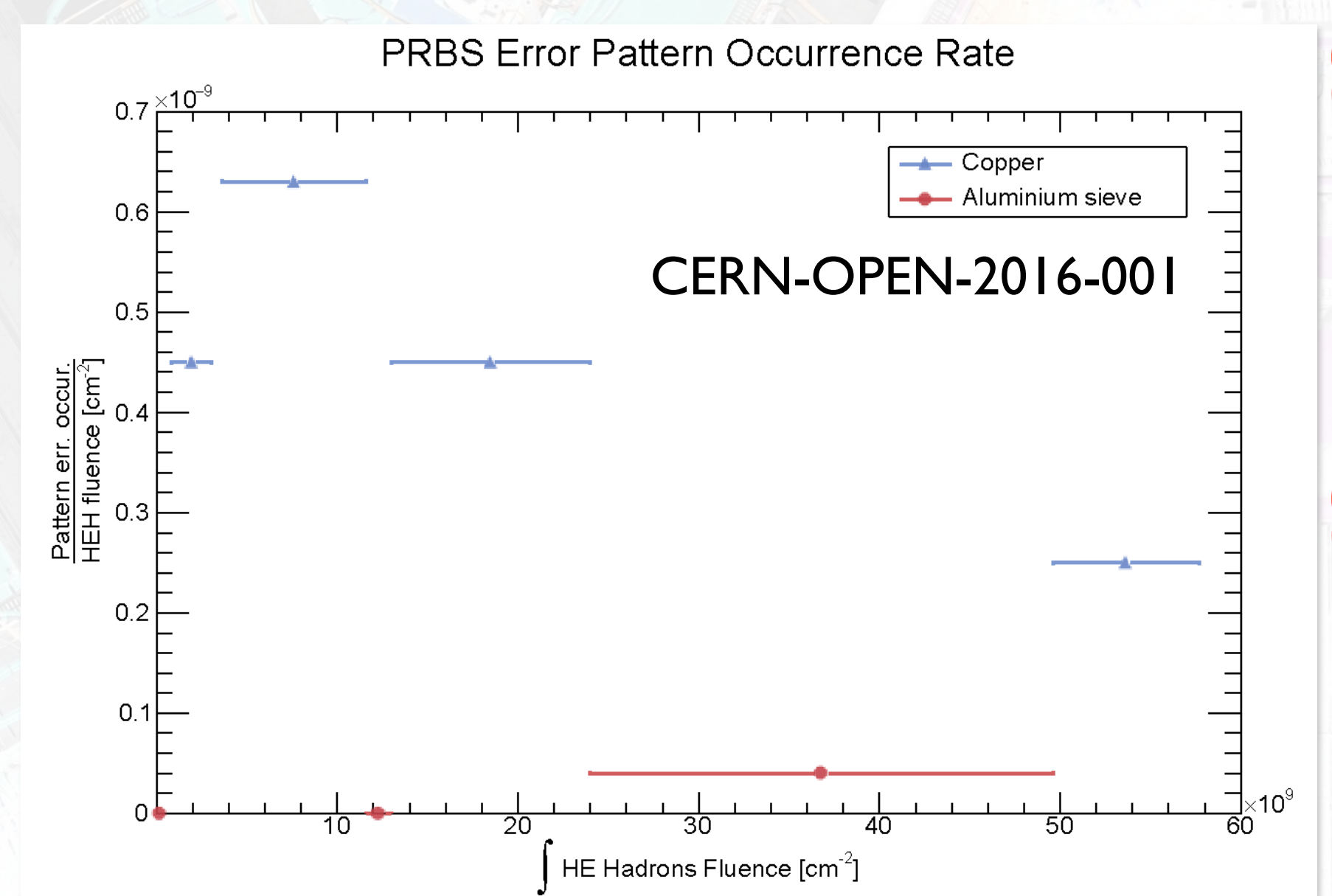

Links

e-mail: francesco.costanza@cern.ch



CMS HCAL Upgrade page



CMS HCAL ngFEC Twiki (CMS internal)



CMS HF and HE irradiation test at the CHARM facility at CERN

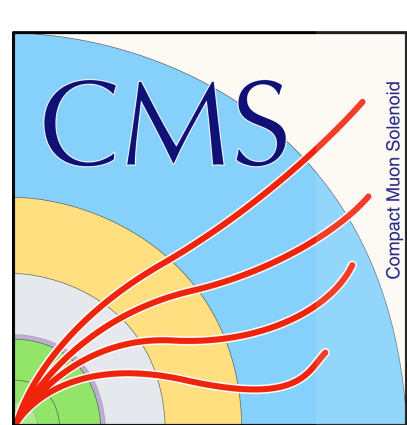

Topical Workshop on Electronics for Particle Physics - TWEPP
26-30 Sept 2016, Karlsruhe Institute of Technology (KIT)

