



# Internet of things

limited only by your imagination

Alberto Pace

# My view...

- It all started in 2005 with the Arduino Uno – 50 EUR
  - 32K Flash, 2K RAM !!
- Open hardware initiative ...
  - Empowered the explosions of
    - compatible devices (clones)
    - compatible peripherals
    - Interconnecting standards (USB, I2C, SPI, Serial, Onewire,
    - ... and, as add-on, TCP/IP either wired or wireless (IOT)



# Where are we today ?

- Same, smaller, cheaper
  - Arduino Nano, Micro, ...

RobotDyn

Nano V3 ATmega168



Nano V3 ATmega168, CH340, MicroUSB,  
Compatible for Arduino **Nano** V3.0

 RobotDyn

 Top-rated Seller

 Chat now!

**US \$1.57** / piece  
Free Shipping

 Feedback(415) | Orders (1361)

 Add to Wish List

# Where are we today ?

- Smaller, better, cheaper
  - ESP8266 – a wifi module where you can use the built in microcontroller
  - 1MB Flash, 45 K RAM



2015 New version 1PCS ESP8266 serial WIFI model ESP-01 Authenticity Guaranteed,Internet of things

 SHEHNZHEN CAIZHIXING ELECTRONIC CO.,LTD

 Chat now!

**US \$1.79** / piece  
Free Shipping

★★★★★ Feedback(37) | Orders (465)

 Add to Wish List

# Where are we today ?

- Faster, cheaper
- The Raspberry Pi
  - A full (linux) computer
  - Quad core, 1 GB RAM, HDMI, 4 USB, Ethernet ...



## NEU Raspberry Pi 3 Model B SBC

RS Best.-Nr. 896-8660  
Marke Raspberry Pi  
Herst. Teile-Nr. Raspberry Pi 3 Model B



SFr.39.22

Preis pro: Stück

1 - 4	5 +
SFr.39.22	SFr.38.78

✓ Lieferung erfolgt innerhalb von 5 Werktagen.

# No upper limit

- Faster, faster, faster ...
  - Odroid XU4, 8 cores, 2GB RAM, USB3, eMMC flash, GB Ethernet, HDMI 4K, Linux or Android



[Buy Now](#)

\$74.00

Worldwide shipping

# To do what ?

- Now you need a dream ...



wholesale hc-05 HC 05 RF  
Wireless Bluetooth Transceiver...  
**US \$2.74** / piece

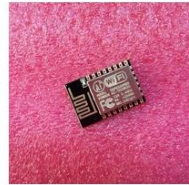

New version ESP-12E (replace  
ESP-12) 10pcs/lot ESP8266...  
**US \$2.08** / piece



10set/lot RF wireless receiver  
module & transmitter...  
**US \$0.59** / pair



50pcs PAM8403 module board 2 \*  
3W Class D digital...  
**US \$0.23** / piece



New LCD 1602 LCD1602 5V 16x2  
Character LCD Display...  
**US \$1.73** / piece



5m DC5V WS2812B led pixel...  
**US \$3.40** / Meter



Free Shipping 4 channel relay  
module 4-channel relay...  
**US \$3.83** / piece



Brand New SERVO Futaba S3003  
Standard Servo RC CAR BOAT  
**US \$3.82** / Set

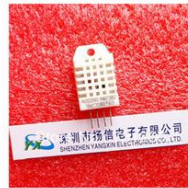

5pcs DHT22 digital temperature  
and humidity sensor...  
**US \$2.94** / piece



5PCS MQ-2 MQ2 Smoke Gas  
LPG Butane Hydrogen Gas  
Sensor...  
**US \$1.36** / piece



Free shipping 1PCS/LOT HC-SR501...  
**US \$0.74** / piece



Free shipping 50pcs Ultrasonic  
Module HC-SR04 Distance...  
**US \$0.84** / piece



# Connecting things

- This is where you start ...



- And here is where you may end ...

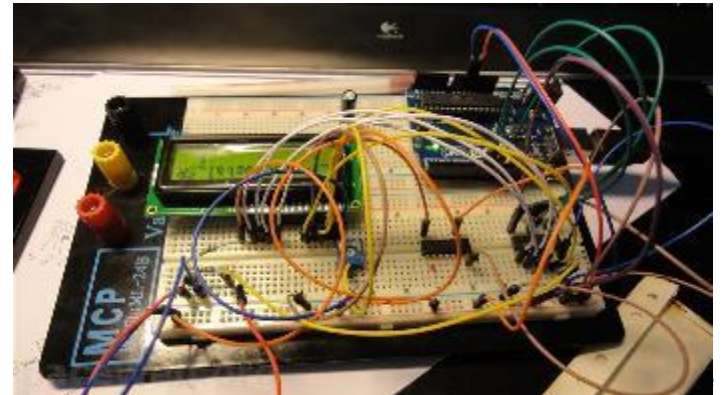
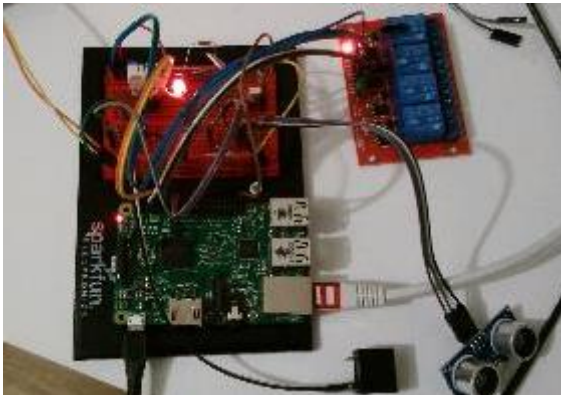

# From prototype to production

- Kicad, Eagle, ...

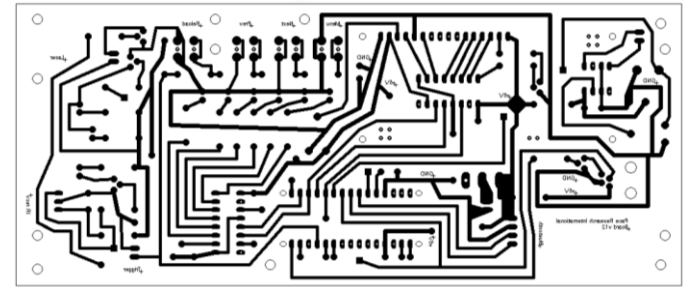
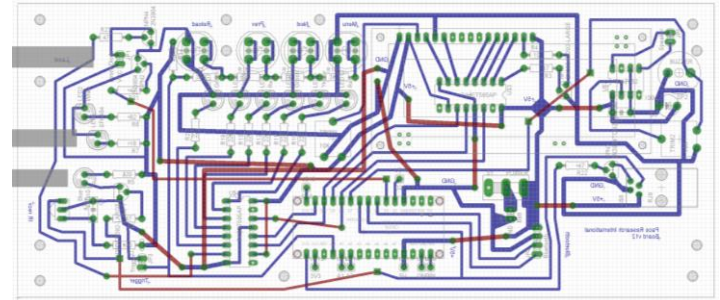
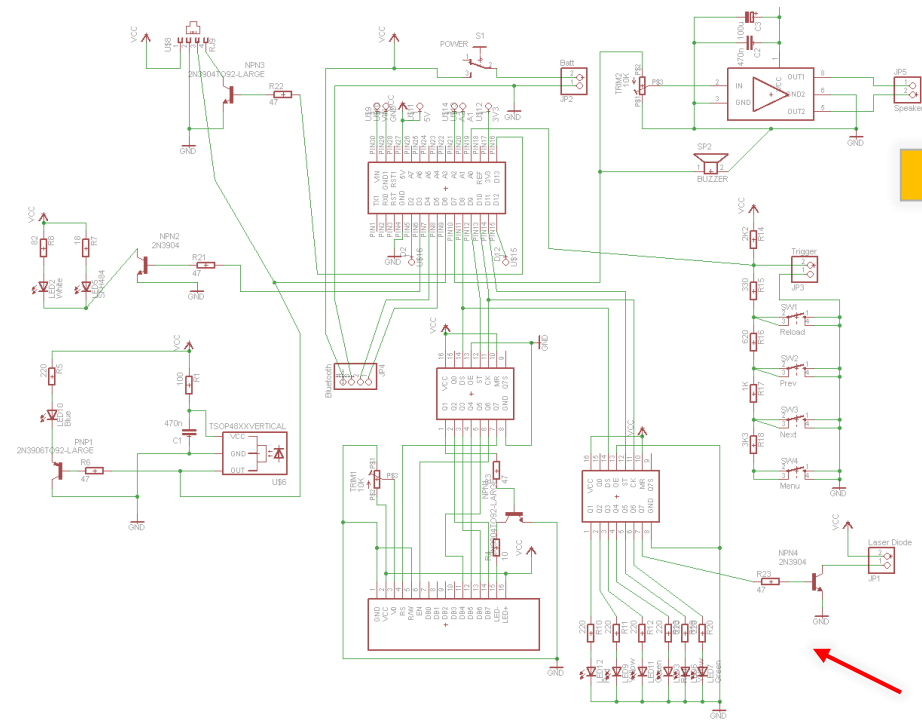

Lasergame gun board

# Printing Circuits

- Photolithography, like old times B&W photography



## Plaques bakélite présensibilisées

Résine positive colorée sur support en bakélite cuivrée avec adhésif de protection.  
Épaisseur de la plaque: 1,6 mm - Épaisseur du cuivre: 35 microns.

Type	Dimensions	Code	Prix
FR2-107	100 x 75 mm	12610	0,87 € HT <b>1,05 € TTC</b>
FR2-1610	160 x 100 mm	12611	1,75 € HT <b>2,10 € TTC</b>
FR2-2015	200 x 150 mm	12612	3,17 € HT <b>3,80 € TTC</b>



## Kit d'insolation K28 Tubes de 28 cm - 8 Watts

Code **12119**

24,17 € HT **29,00 € TTC**



## Révéléateur positif 1 Kg

Code **12560**

11,25 € HT **13,50 € TTC**



## Perchlorure de fer FECL3 pour 1 litre de solution

Code **12060**

6,08 € HT **7,30 € TTC**

# Easy ... after some practice

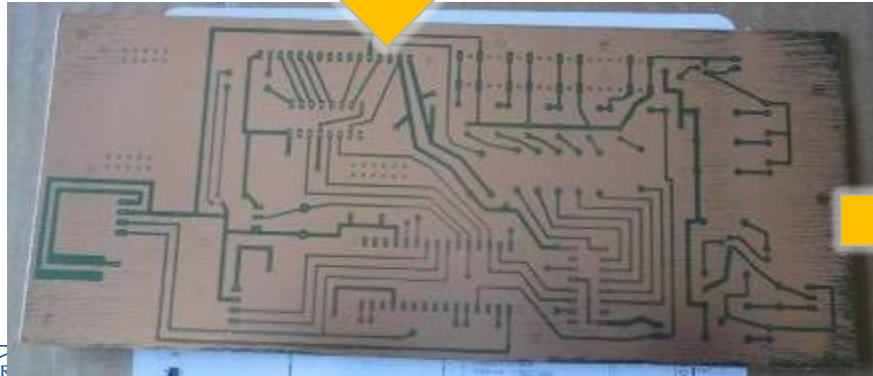
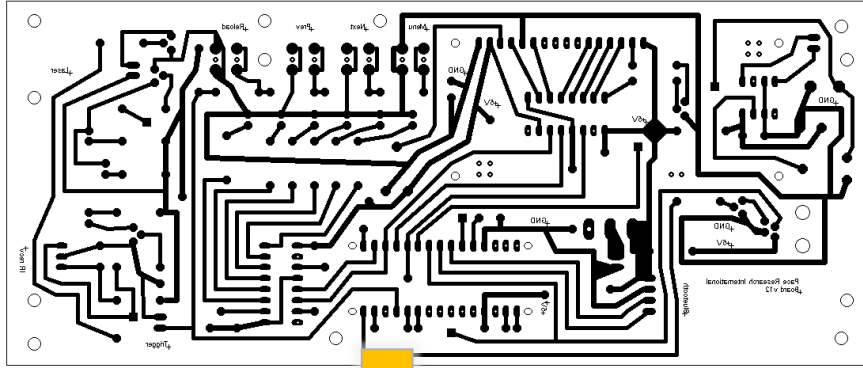

Limited by imagination ...

However, some ideas exist

# (Yet another) digital wall clock

- Synchronized using NTP



# Air, CO and CO<sub>2</sub> Analyzer

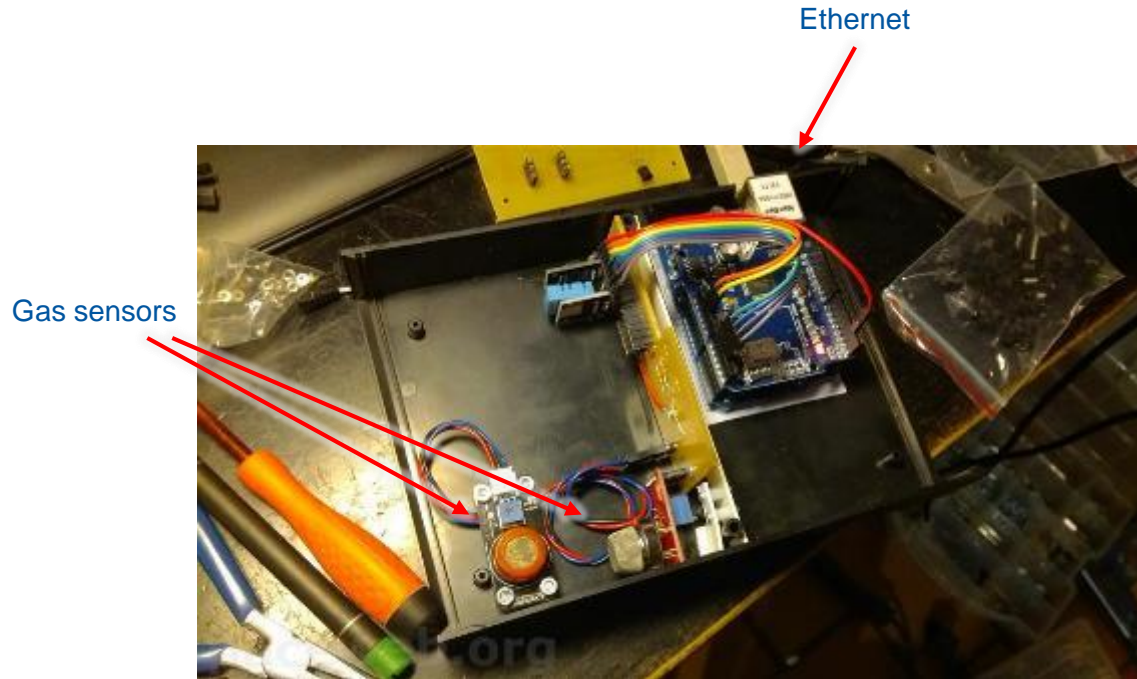

# (a classic) media center

- XBMC / KODI on Raspberry PI 2
- (better use a raspberry 3 or faster)





# Disco psychedelic lights

- Analog electronics for peak detection
  - Lights synchronous with music
- Lights don't stop when music stops



# Home alarm and automation

- Using 433 MHz devices
- Controls unlimited number of plugs

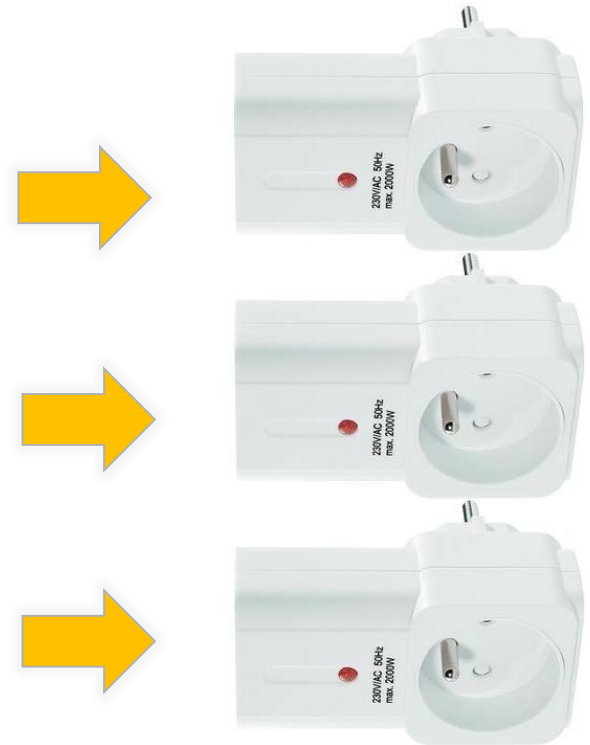
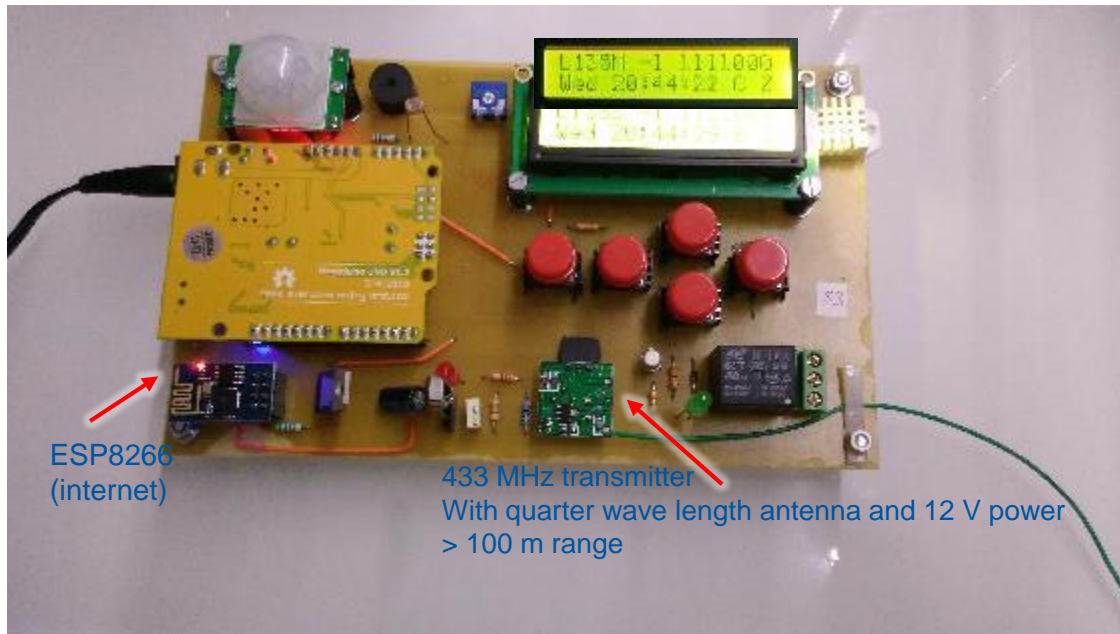

# Electronic scoreboard

- Led strip + Arduino Mega + Bluetooth
- > 500 addressable (WS2812B) RGB leds
- > 1000 lumens, works also as a disco / stroboscope



# Environmental humidity control

- Check Humidity/Temperature inside vs. outside and activate fan
- 2x DHT22, ESP8266, Arduino or Raspberry PI

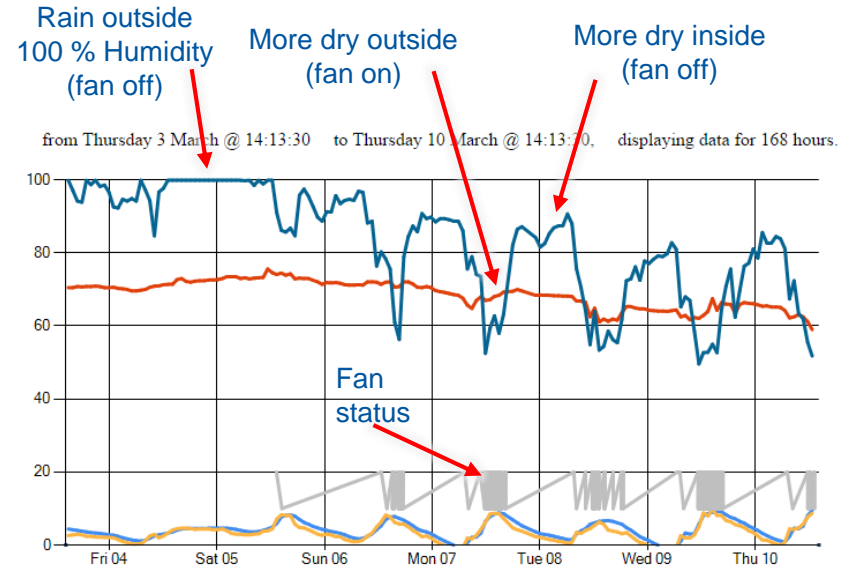
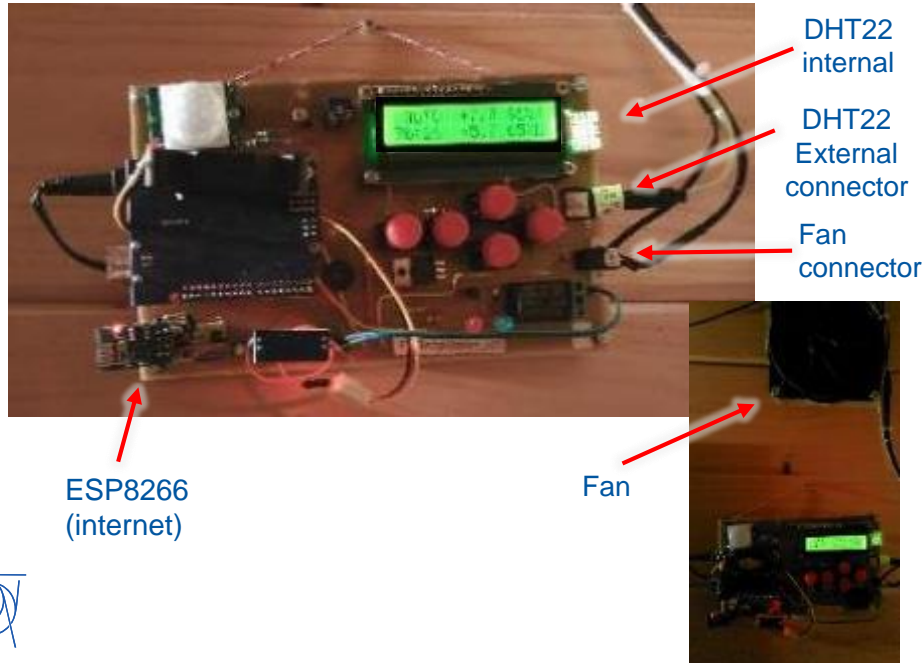

# Cellar pump control

- Pump in water pit
- Ultrasonic sensor, Relay, ESP8266  
Raspberry PI or Arduino

Immerged pump

Ultrasonic  
Water level  
Measurement

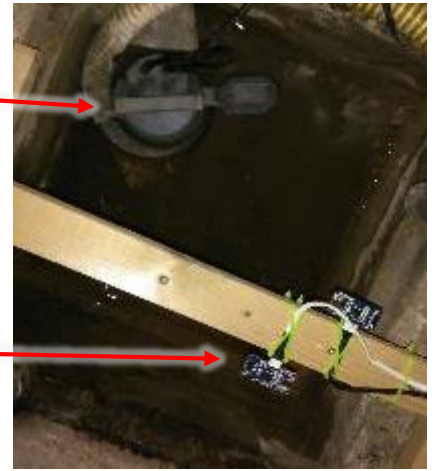

from 22 February 2016 @ 02:16:20 to 07 March 2016 @ 02:16:20, displaying data for 336 hours.

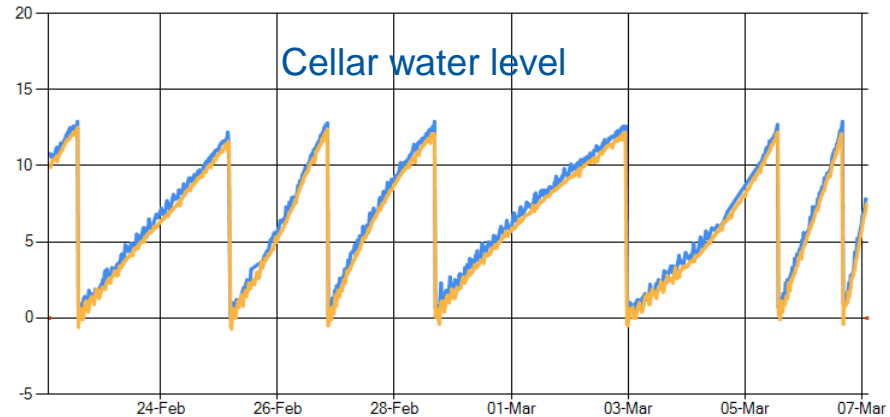

# Multiplayer lasergame

- IR Emitter + Receiver
- Bluetooth communication



target sensors

Base for bonus and life respawn



shotguns



# Build your own CERNBOX

- Owncloud on Raspberry PI or Odroid
  - Prototype “pacebox.cern.ch” with access to 4 TB of storage
  - Excellent performance on the ODROID 8-cores

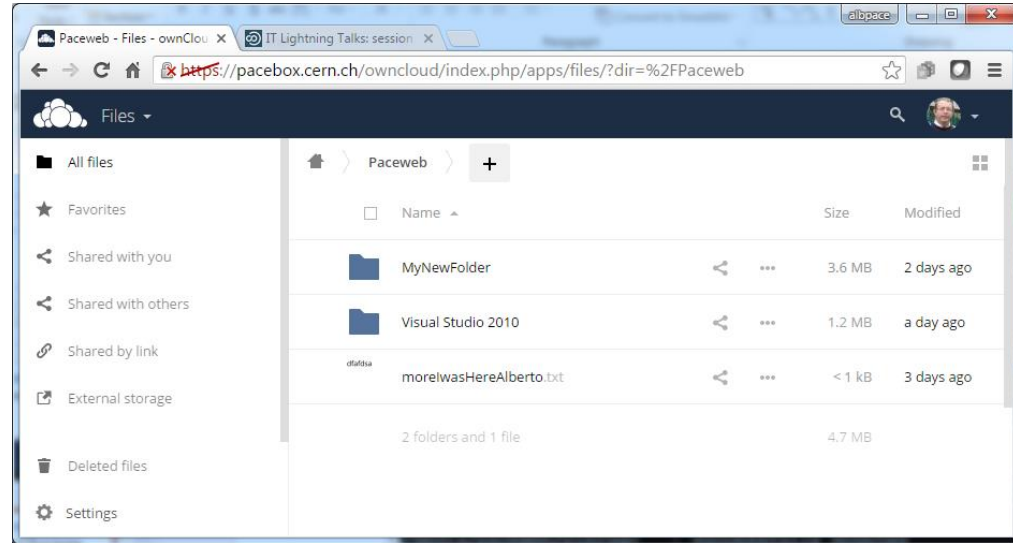

# What's next ?

imagination (and time) is my limitation ...

but you can bet the upcoming technology  
will make things easier