

Study of the Radiation Hardness Performance of PiN diodes for the ATLAS Pixel Detector at the SLHC upgrade

B. Abi, F. Rizatdinova

Oklahoma State University, 148 PS II, Stillwater, OK 74078, USA

babak.abi@okstate.edu

Abstract

We study the radiation tolerance of the silicon and GaAs PiN diodes that will be the part of the readout system of the upgraded ATLAS pixel detector. The components were irradiated by 200 MeV protons up to total accumulated dose 1.2×10^{15} p/cm² and by 24 GeV protons up to 2.6×10^{15} p/cm². Based on obtained results, we conclude that radiation hardness does not depend on the sensitive area or cut off frequency of PiN diodes. We identify two diodes that can be used for the SLHC upgrade.

I. INTRODUCTION

At the SLHC, the luminosity will be increased by a factor of ten compared to the LHC. The radiation level in the ATLAS detector is expected to increase by a similar factor. Current ATLAS pixel detector has to be upgraded to address the higher radiation environment of the SLHC. We use the Non Ionizing Energy Loss (NIEL) scaling hypothesis to estimate the SLHC fluences at the present optical link location (PP0) of the pixel detector of the ATLAS experiment. After five years of operation the SLHC is expected to achieve 3 nb^{-1} of integrated luminosity which corresponds to the fluences as shown in Table 1 [1-2].

Table 1: Beam fluencies.

Beam	1MeV [n _{eq} /cm ²]	200MeV [p/cm ²]	24GeV [p/cm ²]
Si	1.5×10^{15}	1.4×10^{15}	2.6×10^{15}
GaAs	8.2×10^{15}	1.2×10^{15}	1.6×10^{15}

Our goal is to identify the PiN diode candidates which will tolerate the SLHC dose and will have sufficient speed for the optical readouts to be used in tracking detectors at the SLHC. In order to accomplish this goal we designed and built the test stands and developed the methods to study characteristics and radiation hardness and reliability of PiN diodes available on the market vs. irradiation dose.

II. PiN DIODES SELECTED FOR TESTS

We have chosen the following PiN diodes for our irradiation tests:

- A. Si PiN diodes S9055-01 and S5973-01 (single devices).

- B. GaAs PiN diode G8522-XX (single device). This family includes three types with different optical active area and cut off frequency but the same physical structure, which provides an excellent opportunity to study the radiation hardness vs. PiN diode frequency.
- C. GaAs PiN diode G8921-01 (diode die available in 4 to 12 channel modifications). It is a potential candidate for the high speed parallel optical transceiver.

III. PERFORMED TESTS

We performed three major tests to study radiation hardness characteristics of the PiN diodes. First, we performed the total ionization damage (TID) test at BNL using gamma rays with a total dose of 10 Mrad. The purpose of this test was to confirm that the performance of PiN diodes is not affected by the gamma irradiation.

Second, we did two identical tests at Indiana University Cyclotron Facility (IUCF). The tests were done in two phases with two weeks interval which allowed us to observe a possible annealing effect. At each phase we irradiated diodes with 200 MeV protons up to 0.7×10^{15} p/cm² with a total fluence of 1.4×10^{15} p/cm². These tests were done using the Open-air Optical Path approach described below. The main goal of the tests was to measure the PiN diode responsivity as a function of accumulated dose. In addition we wanted to figure out if the degradation of the responsivity depends on the active area and cut-off frequency of PiN diodes. For this purpose we used 3 PiN diodes from the G8522 family.

Finally, we did the irradiation tests at CERN T7 test beam facility using 24 GeV proton beam and a total fluence of 1.5×10^{15} p/cm² for GaAs and 2.6×10^{15} p/cm² for Si diodes. We studied the same set of PiN diodes using different experimental setup to cross-check the results obtained at different beam energy.

IV. TID TEST AT BNL

The gamma ray source at BNL is a cylindrical cobalt-60 source with maximum irradiation rate of 200 kRad/h positioned at 6 inches from the center of the source. Diodes chosen for the test were biased, so we could make offline measurement of responsivity as a function of accumulated dose. For the measurement of responsivity we used a homogenous infrared (IR) source biased by a constant current. Figure 1 shows the schematics of the setup for optical calibration and responsivity measurement. Samples have been installed at the irradiation point at 6 inches from the source to get the maximal dose. The accumulated dose is known with

20% accuracy. Responsivity was measured offline at 0 Mrad, 5.6 Mrad and 9.6 Mrad. Figure 2 shows responsivity versus total dose. No change in responsivity has been observed after 9.6 Mrad.

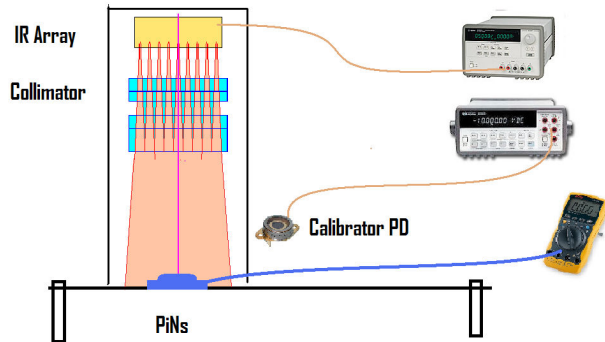

Figure 1 : Schematics of the optical setup for BNL tests.

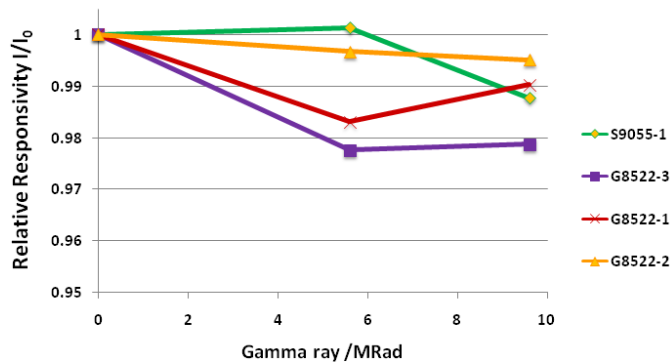

Figure 2 : Responsivity vs. accumulated dose obtained at BNL tests.

V. OPEN-AIR OPTICAL PATH TEST STAND

For the second set of tests we introduced a new concept of a test stand for optical components like PiN diodes, named Open-air Optical Path, which has many advantages. First, it allows us to avoid any parasitic effects and random mechanical attenuation from optical circuits and connectors. With this concept we can remove the effect of optical packages in final measurement and simplify the test setup. Another benefit is the ability to easily test a large number of samples. The test stand is characterized by simplified electrical and DAQ circuitry. It allows us to monitor and control the optical power of the sources with high accuracy. Figure 3 shows the motherboard which includes a high power IR power source with a wavelength of 850 nm focused precisely at the center of the daughterboard which carries the PiN diodes. Figure 4 shows the daughterboard with installed PiN diodes. The motherboard is positioned in such a way that the beam crosses the PiN diodes but does not touch the optical sources which are installed on the ring. The daughterboard is detachable from the motherboard to allow for quick and easy measurement of multiple samples.

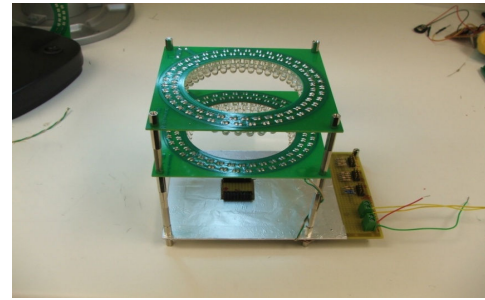

Figure 3 : Open-air Optical Path motherboard.

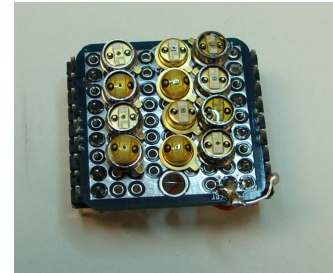

Figure 4: Daughterboard with PiN diodes.

VI. TESTS AT IUCF

The second set of tests was performed at Indiana University Cyclotron Facility (IUCF) using 200 MeV proton beam. The IUCF's beam is 5 cm in diameter and has a maximum irradiation rate of 5 Mrad/h. We used the Open-air Optical Path test stand. The test has been performed in two separate runs. The accumulated dose in each run was 0.7×10^{15} p/cm² (40 MRad). Since the IR source was losing power during the run due to secondary radiation, its optical power has been monitored, and the results of the PiN diode responsivity measurements have been corrected for this loss. Figure 5 shows the results of the responsivity measurement for two types of PiN diodes (S8522-1 and 3) with and without compensation. The lines marked "ON" take the compensation into account. The small plot on top shows the normalized optical power of the source.

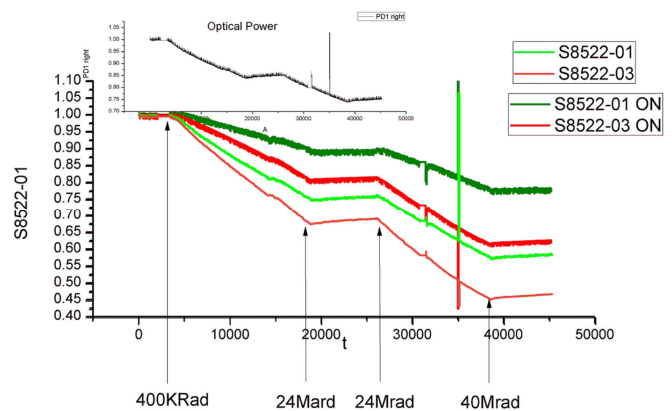

Figure 5 : Responsivity vs. accumulated dose obtained at IUCF tests.

Figure 6 shows the results of the first irradiation phase with normalized responsivity but without optical power variation compensation.

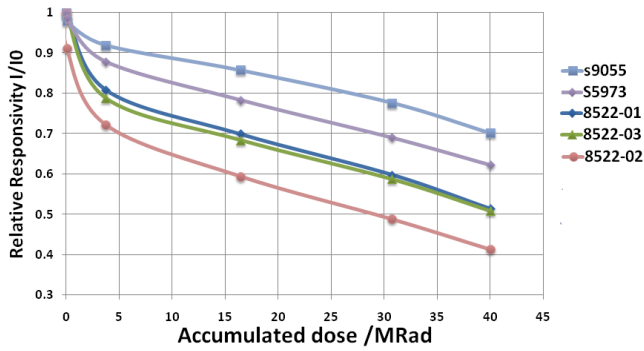

Figure 6 : Responsivity vs. accumulated dose obtained in the first IUCF run (no optical variation compensation).

Table 2 shows total responsivity degradation after 80 Mrad of accumulated dose using 200 MeV protons. The results are corrected for the optical power fluctuation. The results for the G8522-0X diode family show no correlation between responsivity and size of active optical area.

Table 2 : final results responsivity

Pin	Total degradation [%]
S9055-01	12
S5973-01	33
G8522-01	34
G8522-02	29
G8522-03	55

VII. TESTS AT CERN T7 FACILITY

We performed a test at CERN T7 facility with 24 GeV protons with beam profile of 2 cm. Figure 7 shows the test stand we designed to be used at T7. The stand has 32 optical channels, but can be expanded up to 256 channels. It has a compact, portable footprint. The stand provides a fine control of the optical power for each individual channel. It can be also modified into a bit error rate test stand. The test stand is controlled by a PC running LabView.

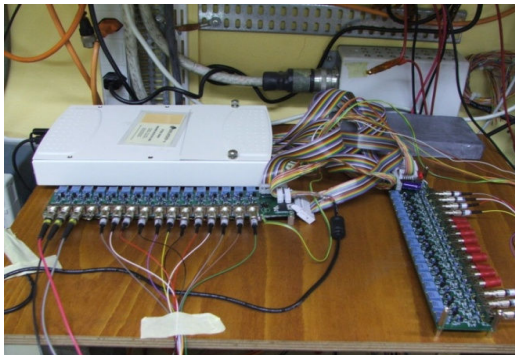

Figure 7 : Test stand used at CERN T7.

At T7, the proton beam is about 20 m away from the control room and samples have to be installed in a shuttle to reach the beam. Samples in a shuttle are connected via fiber ribbons to the VCSEL modules at the test stand. Every 30 seconds, the

test stand reads out the optical power sent to the PiN diodes and the currents of each individual channel of PiN diodes as a measure of responsivity.

Figures 8-10 show degradation of the PiN diode responsivity due to irradiation with 24 GeV protons. This degradation is in a good agreement with results obtained at 200 MeV at IUCF. Figure 8 shows that the S5793-01 diodes lost about 30% of their initial responsivity, to be compared with 33% at IUCF. Figure 9 shows that with total fluence of 2.6×10^{15} p/cm² the S9055-01 diodes lost about 10% of their initial responsivity which is in agreement with 12% at IUCF. Finally, Figure 10 shows responsivity plots for the GaAs PiN array with an average of 50% loss of responsivity.

The responsivity shown in these plots is calculated taking into account the optical power fluctuations of the optical sources.

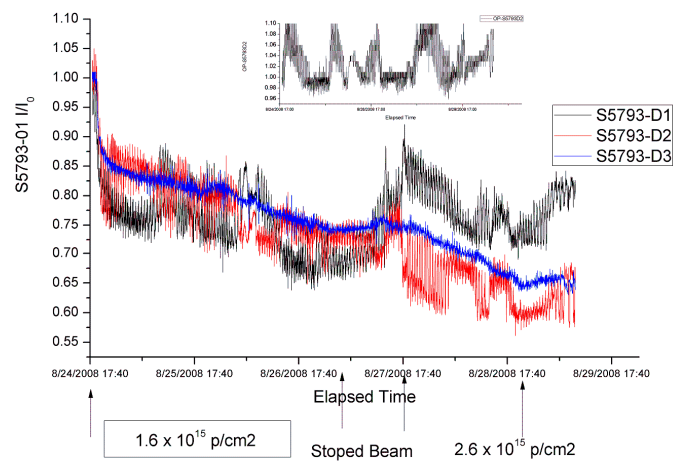

Figure 8 : Responsivity vs. accumulated dose obtained at CERN T7 (three diodes S5793-01).

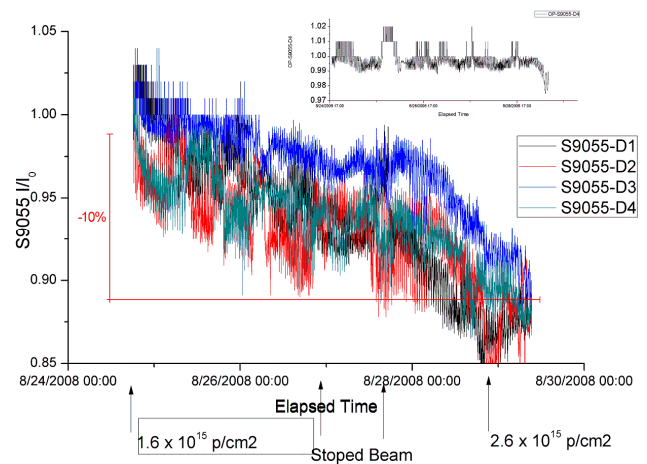

Figure 9 : Responsivity vs. accumulated dose obtained at CERN T7 (four diodes S9055-01).

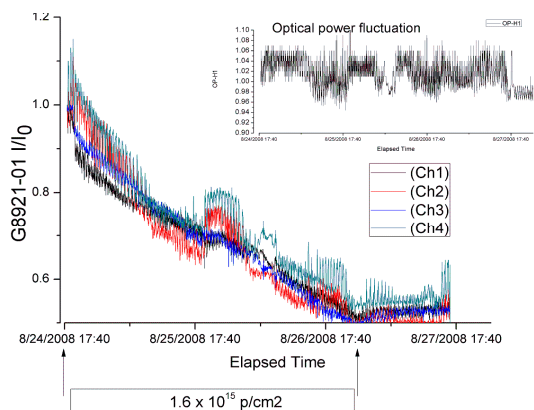

Figure 10 : Responsivity vs. accumulated dose obtained at CERN T7 (diode G8921-01, 4 channels)

VIII. SUMMARY AND CONCLUSIONS

We developed and built three test stands for PiN diode responsivity studies and performed irradiation tests at three different beam facilities. Our results demonstrate that radiation hardness does not depend on the active area of PiN

diodes from the same family. Results obtained at two different proton beam energies (200 MeV and 24 GeV) are found to be in a good agreement with each other. Based on results from IUCF and CERN irradiation runs we identified the following PiN diode candidates:

- a) GaAs array G8921-01 with total responsivity degradation less than 50% (initial photosensitivity is 0.5 A/W). Its responsivity after irradiation is better than for S9055-01. It is available in different configurations (4 to 16 channels per array).
- b) Si PiN 9055-01 with total degradation less than 10% (initial photosensitivity is 0.25 A/W).

These candidates can be used for other applications in high radiation areas at the LHC and SLHC.

IX. REFERENCES

1. I. Gregor, "Optical Links for the ATLAS Pixel Detector," Ph. D. Thesis, University of Wuppertal, 2001.
2. A. Van Ginneken, "Non-ionizing Energy Deposition in Silicon for Radiation Damage Studies," FERMILAB-FN-0522, Oct 1989, 8pp.