

Phase II DAQ and “Scouting” Option

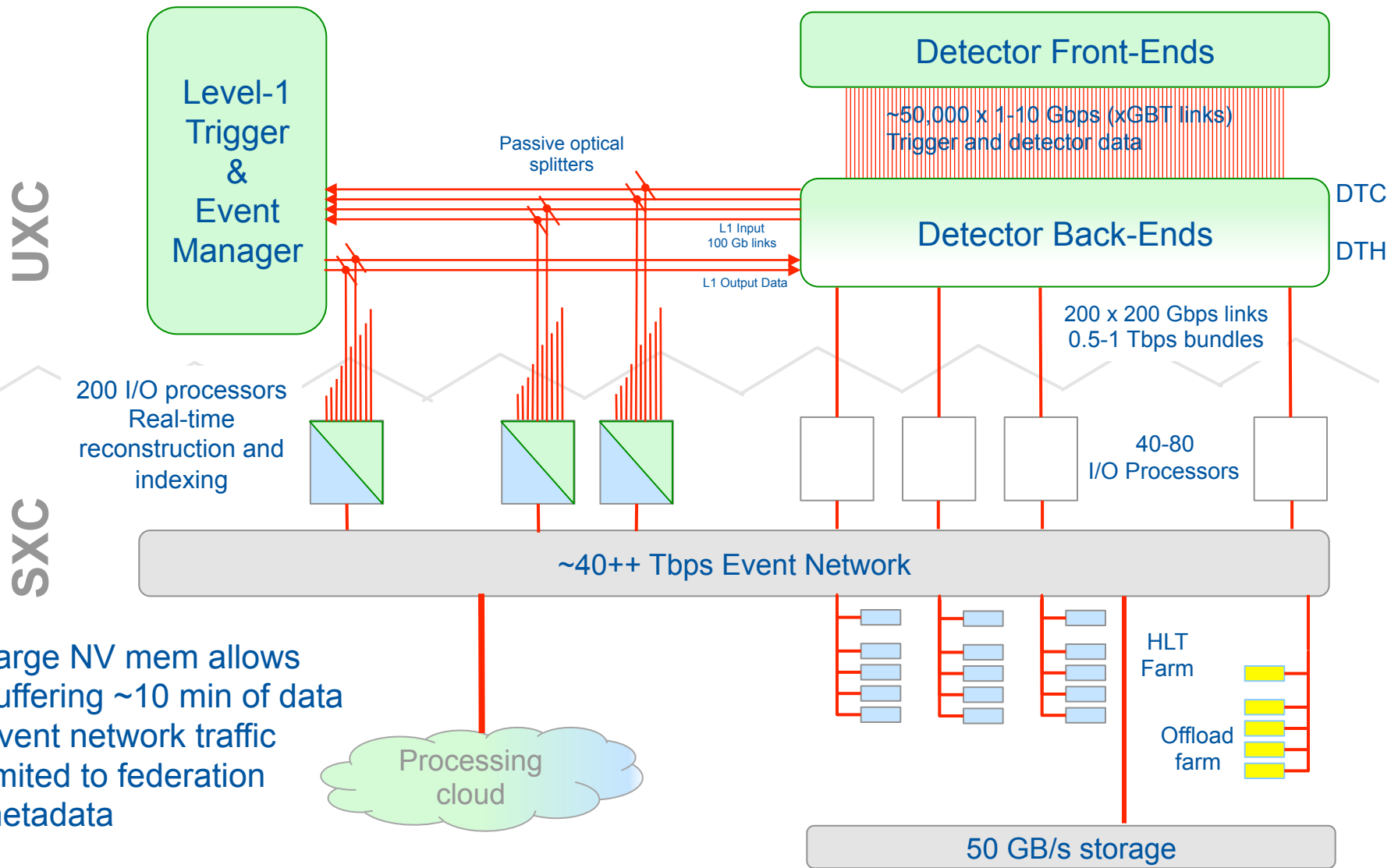

Final Remarks

- Baseline DAQ architecture for Run4 feasible with readily available technology
- Reduction of complexity and cost may result from tracking and late adoption of maturing technologies
- “Scouting” at 40 MHz may offer interesting physics opportunity
 - No need to build anything for day 1