

The design of a fast Level 1 track trigger for the ATLAS High Luminosity Upgrade

CHEP 2016

Benedict Allbrooke on behalf of the ATLAS Collaboration

University of Sussex

11th October 2016



- Motivation
- Level 1 Track Trigger Strategy
- Pattern Recognition:
 - Pattern Creation
- Track Fitting:
 - Fit Constant Determination & Sectors
 - Fit Application Strategy
- Performance studies:
 - Pattern & Fit Performance
 - Performance in Physics Rols
- Latency Estimation:
 - Discrete Event Simulation

Motivation

- The high-luminosity LHC is expected to deliver instantaneous luminosities of $\sim 7.5 \times 10^{34} \text{ cm}^{-2} \text{ s}^{-1}$
- Huge reach into new physics and precision in measurements of rare decays including Higgs decays modes not yet observed
- High pileup, up to $\langle \mu \rangle \sim 200$, represents a challenge for trigger both in terms of event rate and high flux of particles
- Tracking currently performed in High Level Trigger(CPU Farm)

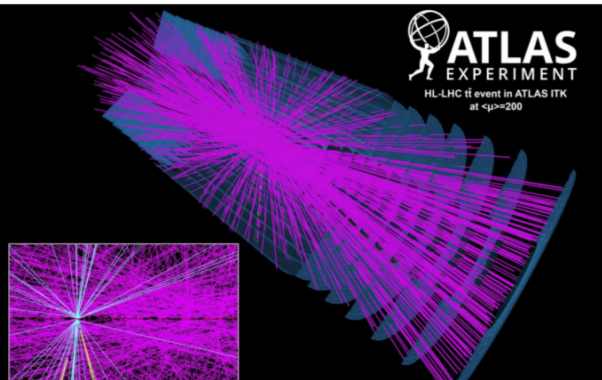

- Huge flux of inner detector pileup tracks

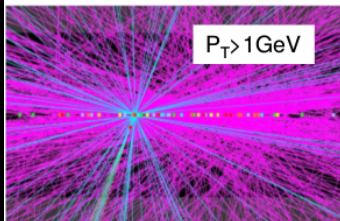

Motivation for a Track Trigger

- Luminosity this high would swamp the high level trigger in the current setup and push the readout rate beyond capabilities
- Operating current trigger would require increasing thresholds of single lepton triggers \rightarrow very large loss of physics potential
- Alternative strategy: hardware-based track reconstruction \rightarrow should achieve similar rate reduction for single lepton triggers
- Potential to increase acceptance, especially central muons

CERN-LHCC-2012-022

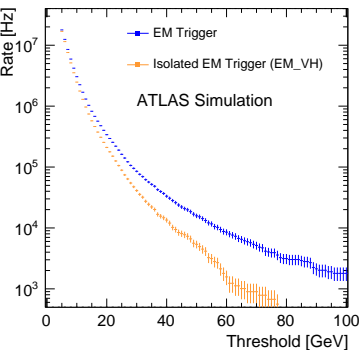

CERN-LHCC-2012-022

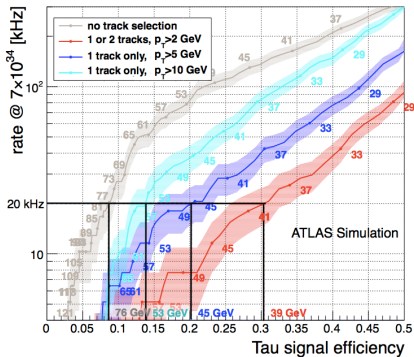

L1Track Pattern & Fit Strategy - Similar to ATLAS FTK

Proposed Level 1 Track Trigger (L1Track) baseline design:

- Seeded by Regions of Interest (RoI) found in base Level 0 Calo and Muon triggers (similar to current hardware-based Level 1)
- ITk (upgraded Inner Detector tracking) readout into L1Track

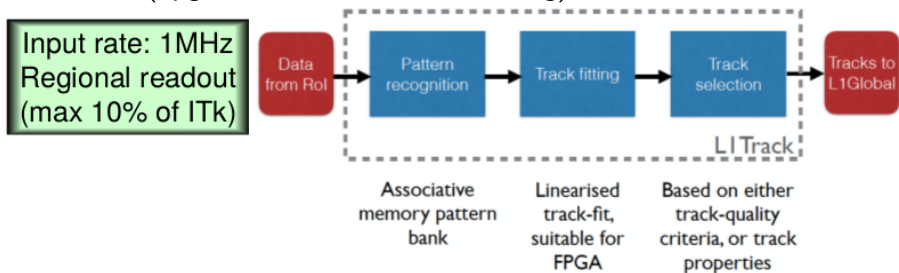

- Clusters passed in as coarse granularity “Superstrips” which are checked against patterns within Associative Memories
- Matched patterns: track fit performed with full granularity hits within FPGAs to select tracks for global L1 decision

(More details of Trigger architecture in talk by S. George)

Pattern Finding - Similar method to current ATLAS FTK

- Patterns pre-computed using $O(100m)$ single MC muons in each $\eta \times \phi = 0.2 \times 0.2$ region
- Muons flat in $1/p_T$ with $p_T > 4\text{GeV}$, $|d_0| < 2\text{mm}$ & $|z_0| < 150\text{mm}$
- Aim for bank size $\sim 10^6$ per regions

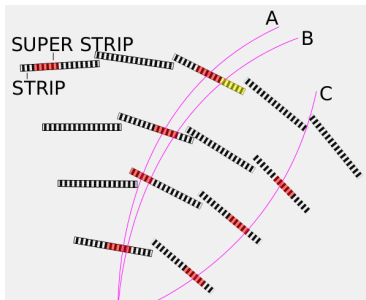
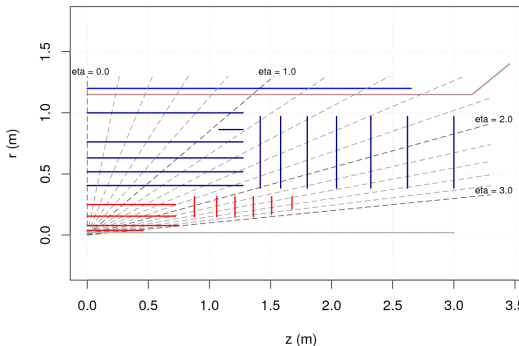

- Subset of layers forms patterns with strips merged into “Superstrips” in each layer
- Pattern: sequence of Superstrips
- Wildcards: Allow missing hits
- Don't Care Bits: merge mostly overlapping patterns to reduce bank size

Fit Constant Determination and Sectors

- Within the ITk: have the cluster positions $\{x_j\}$ and want to relate them to the track parameters $\{p_i\}$
- Use a linear approximation, with similar definition for χ^2 :

$$p_i = \sum_{j=1 \dots N} C_{ij} x_j + q_i$$

- Hits on same layer in different modules don't have continuity in x_j which would break linear approximation
- Use this to define a sector: a given set of ITk modules/layers
- Need constants for each sector
- $\{C_{ij}, q_j\}$ produced from simulation by principal component analysis from MC single muons

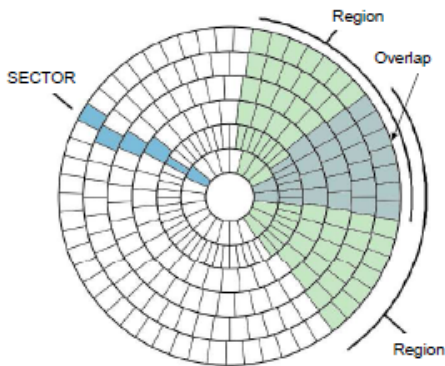

Strategy for Fits and Sectors

- For each matched pattern find the sector in which the pattern is found
- Load the set of constants for $\{p_i\}$ $\{C_{ij}, q_j\}$ and χ^2 $\{A_{ij}, k_j\}$ for this sector
- Compute the χ^2 to accept/reject the candidate track
- If accepted then compute the track parameters

Possible Issues:

- 1 Combinations in each pattern:
Compute χ^2 for each possible combination and keep best
- 2 Missing hits: Drop each 1 or 2 layer possibilities and compute the n-1 and n-2 constants for use with the Wildcard patterns

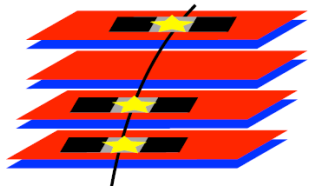
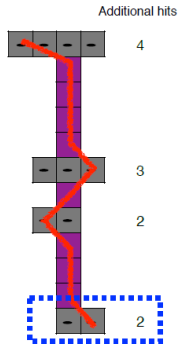

Pattern and Fit Performance

twiki.cern.ch/twiki/bin/view/AtlasPublic/L1TrackPublicResults

- Procedure performed separately (and requiring different tracker layers) in each η region \rightarrow Shown here for central barrel $0.1 < \eta \leq 0.3$
- Strip-only case studied in detail
- Improvements observed by swapping 1 strip layer for pixels but at cost of number of fits
- Same patterns and sectors used for μ, e, π (right)

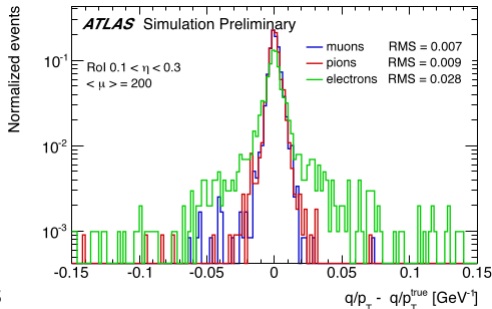

	ϵ_{pat}	ϵ_{fit}	$\langle N_{fits} \rangle$
Strip Only	99.5%	98.6%	87
Strip+1 pix	99.3%	99.4%	191

Good resolutions for μ (below) show promise for use in signatures:

	Curv [GeV^{-1}]	ϕ	η	$d0$ [mm]	$z0$ [mm]
Strip Only	0.007	0.003	0.012	1.09	8.7
Strip + 1 pix	0.003	0.001	0.001	0.2	0.6

Performance in Physics Rols

- Overlay single electron and single muon (weighted to that expected from L0 triggers) with $\langle \mu \rangle = 200$ pileup
- Compare efficiency with b-jet background track efficiency

Level 0 MU20:

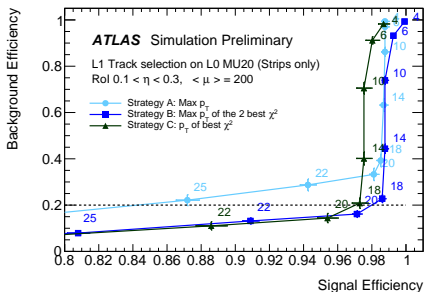

Level 0 EM18:

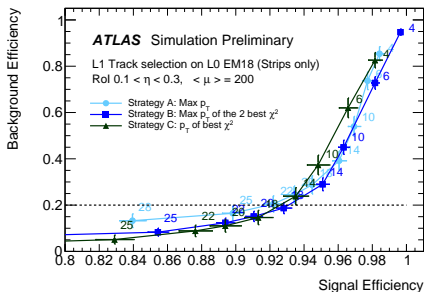

twiki.cern.ch/twiki/bin/view/AtlasPublic/L1TrackPublicResults

Three strategies to choose the best candidate track within an Rol:

- Take highest p_T track of all candidate $\chi^2 < 40$
- Highest p_T of two with lowest χ^2 (also $\chi^2 < 40$)
- Candidate track with best χ^2

Latency Estimation

- Level 1 Track Trigger will have to act within short latency budget → requires fast data collection & fast processing ($\sim 15\mu\text{s}$)
 - Discrete Event Simulation created to simulate data flow out of ITk readout for HL LHC scenario
 - Used to determine viability of scenarios
-
- Latency of Pattern matching and track fitting very subject to hardware description → not expected to be limitation
 - Expected FPGA latency of 4 track fits per ns → event with a few Rols $O(\mu\text{s})$
 - Expected AM input capacity $\sim 200\text{MHz}$ → for highest occupancy layer $O(\mu\text{s})$

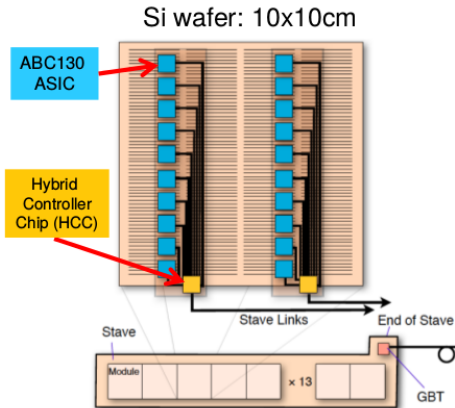

Latency Estimate

- To get data into L1Track quickly: mark clusters falling within L0 Rols as “Priority” → jump ahead when bottlenecking
- Expect maximum of 10% marked as prioritised

Map of Prioritised Latency:

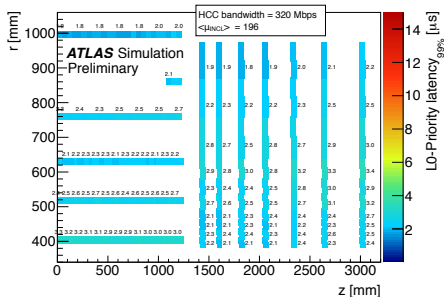

Highest Latency Barrel Module:

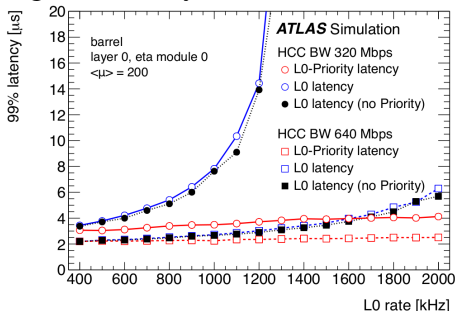

twiki.cern.ch/twiki/bin/view/AtlasPublic/L1TrackPublicResults

- Little cost to latency of non-prioritised data
- Prioritised data safe within rough limit of $6\mu\text{s}$ for 1MHz rate
- Investigating higher bandwidth links and readout scenarios

Conclusion

- High Luminosity LHC presents challenge to ATLAS Trigger
- Hardware-based track trigger essential to avoid escalating single lepton thresholds
- Patterns and fit constants work well to extract good candidate tracks
- Method provides good parameter resolution and therefore opportunity for different trigger signatures
- Should be possible to process within latency budget
 - Level 1 Track Trigger can achieve required trigger/physics performance
 - More studies and R&D required for full Level 1 Track Trigger plan but studies so far are promising

