

RPC for SHiP

G. Iaselli

On behalf of:

INFN Bari

INFN LNF

INFN LNGS

INFN Naples

*Many thanks to G. De Lellis, M. Ambrosio,
S. Simone, A. Paoloni for extensive
discussions and help in preparing these short
notes*

The present SHiP proposal includes an RPC spectrometer for the ν_τ detector

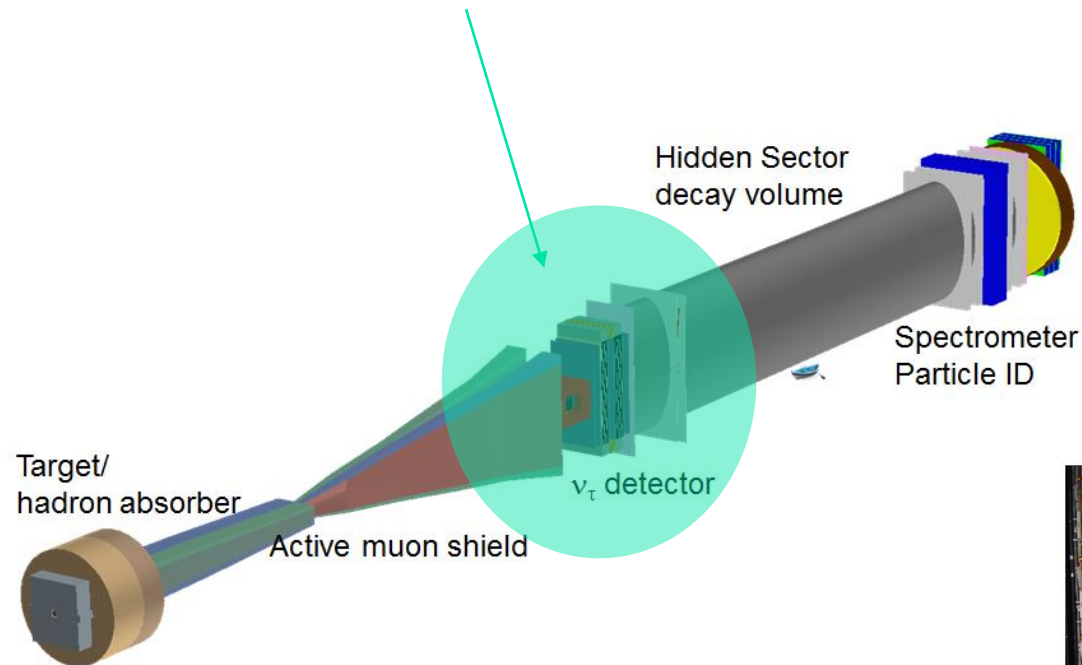

The OPERA spectrometer

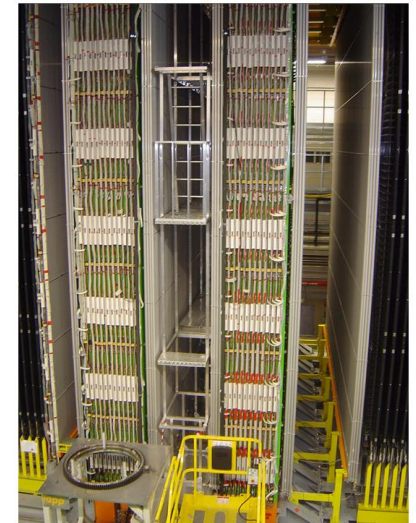

The OPERA magnetic spectrometer

One spectrometer is composed by:

- 1 dipolar magnet (1.52 T)
- 22 RPC layers as inner tracker inside magnetized iron
- 6 drift tubes stations (PT stations)
- 2 external XPC stations

Muon identification $> 95\%$
 $\Delta p/p < 20\%$ for $p < 30$ GeV
Charge misidentification $< 0.3\%$

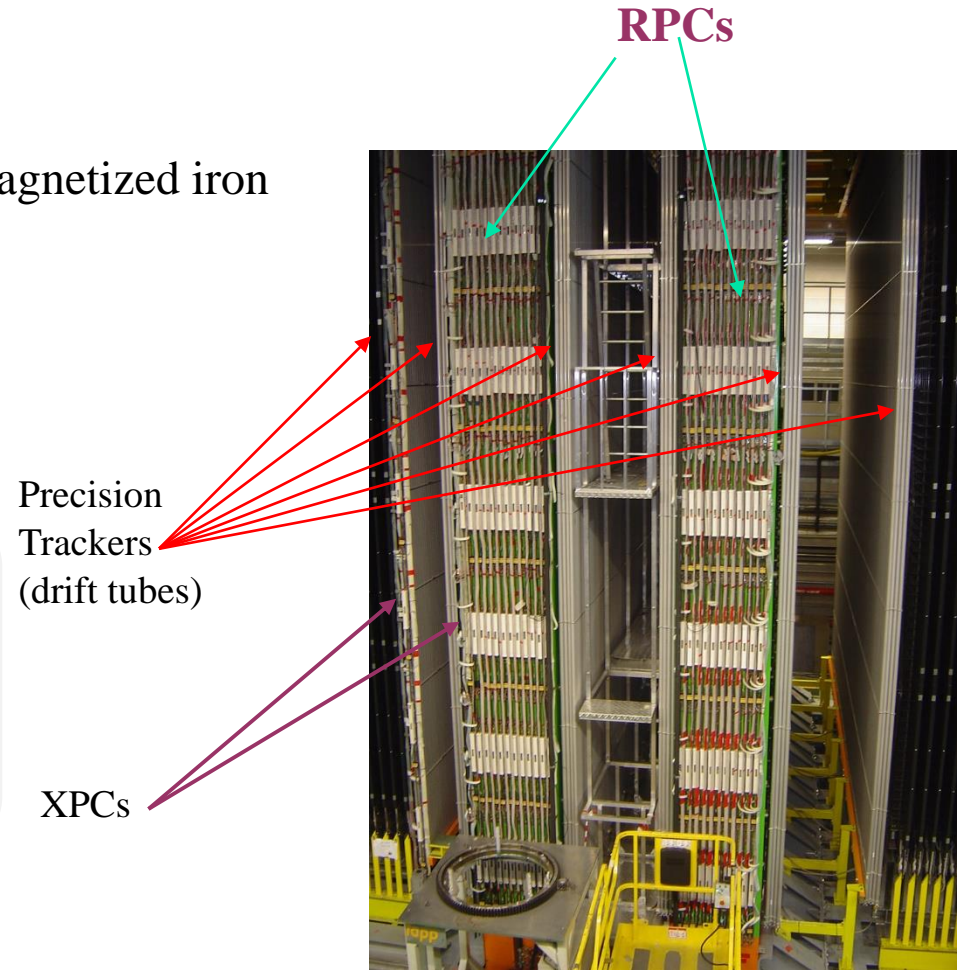

About 3000 m² RPCs

- High resistivity HPL electrodes
- Streamer mode operation (large signals)
- Read-out by means of ~8 m x-y strips
- 28000 digital electronics channels

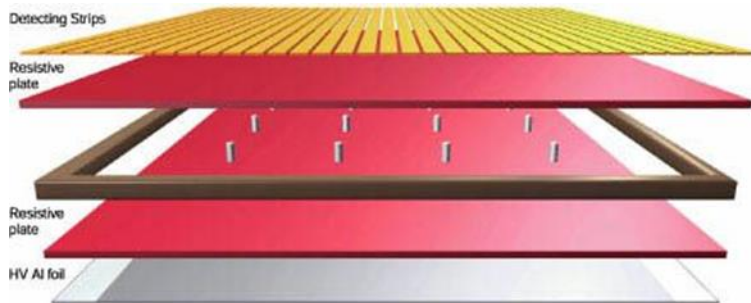

Standard HPL (bakelite) RPCs operated in streamer mode

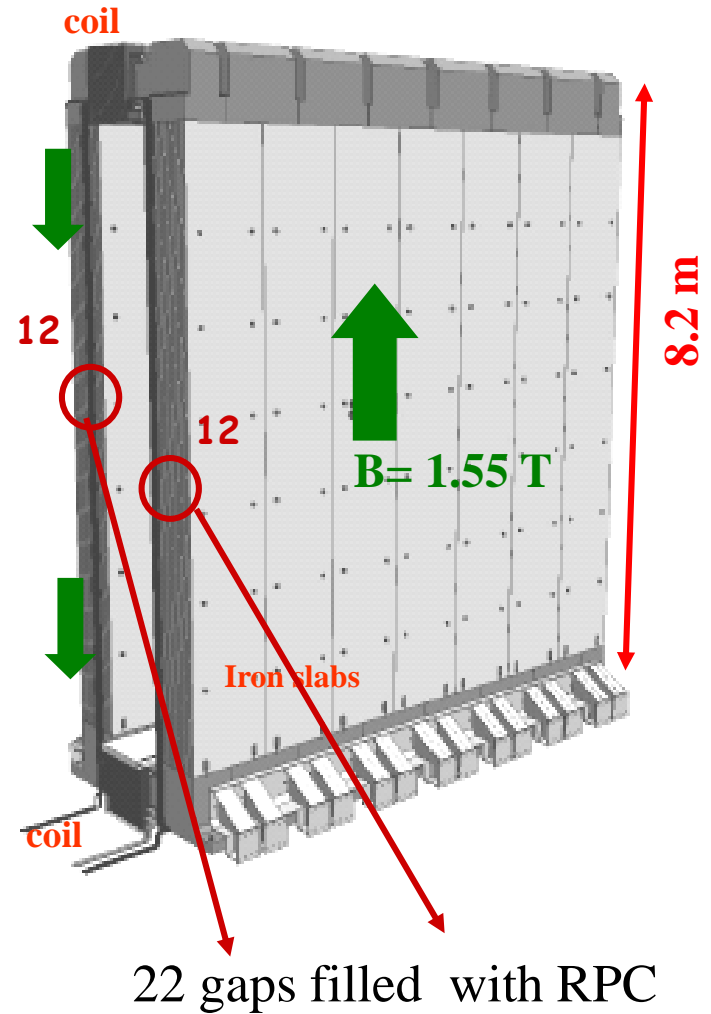

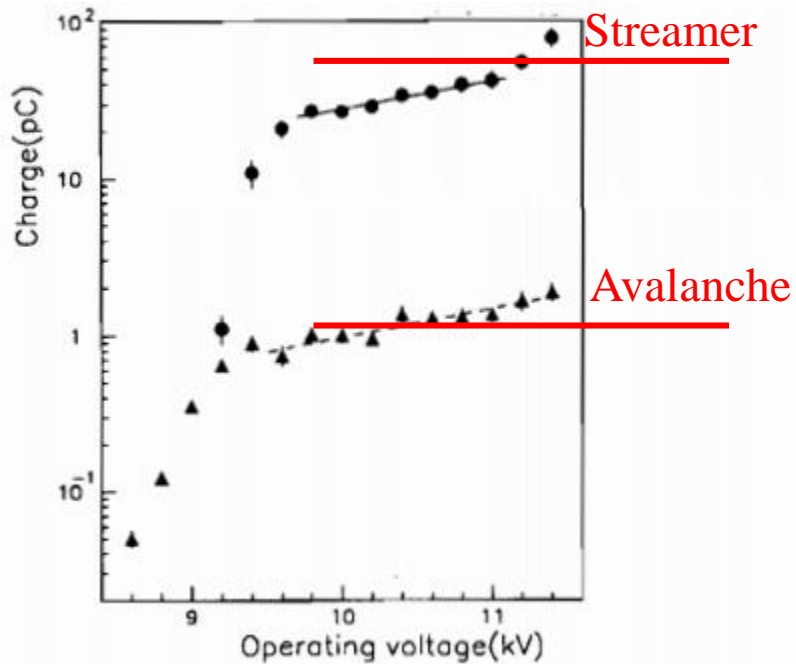

The extremely quiet environment at LNGS has allowed the use of traditional RPCs operated in streamer mode.

- Electrode resistivity $5 \cdot 10^{11}$ Ohm cm
- Signal charge > 100 pC

No amplification is needed on the front-end board

Background conditions at LHC experiments ($10\text{-}50$ Hz/cm²) has imposed avalanche operation to sustain high particle rates.

- Electrode resistivity 10^{10} Ohm cm
- Signal charge 1 pC

Signal amplification is needed on the front-end board



Expected rates in the SHiP neutrino detector from recent simulations

10 Hz/cm²

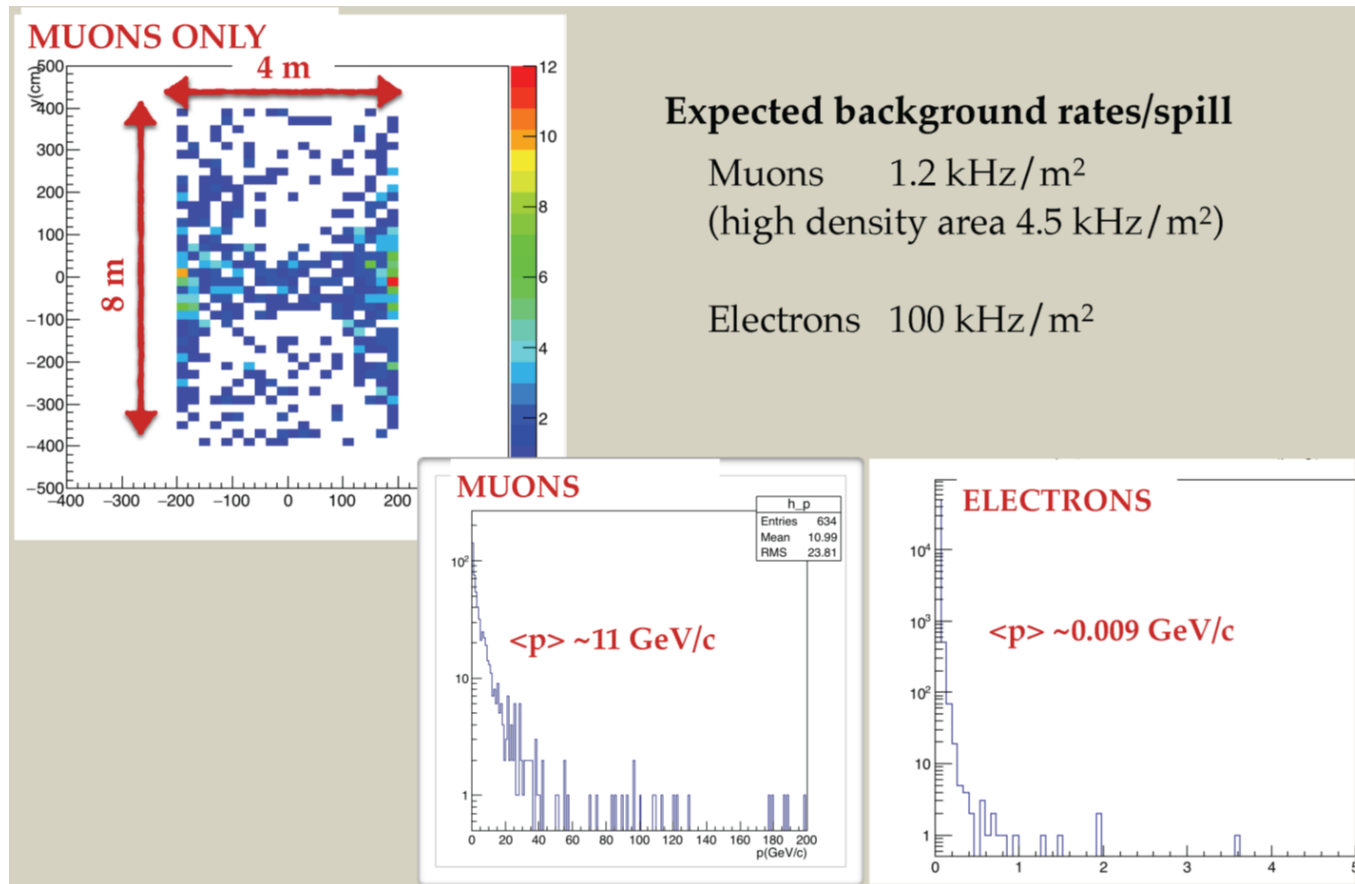

10 Hz/cm²

Perhaps operation in streamer still possible, with large voltage drop across the detector due to high electrode resistivity (500-600 volts over an average operation voltage of 6000 volts)

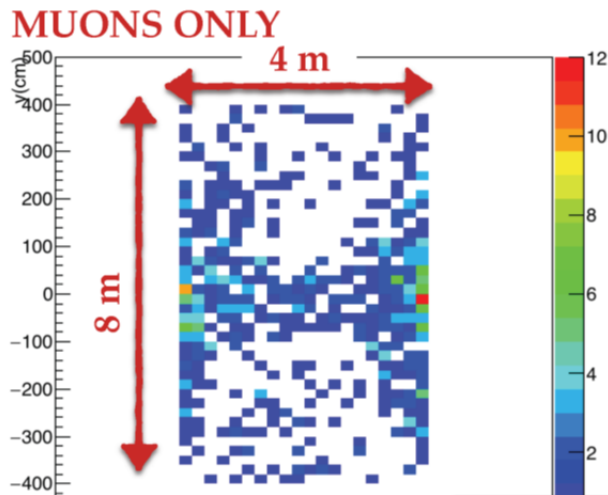

Also, due non homogeneity in the flux distribution, different region would see a different voltage drop and therefore work at different operation voltage.

Avalanche operation mode would add a safety margin toward background fluctuation and ensure long term ageing performance (less charge developed in the detector)

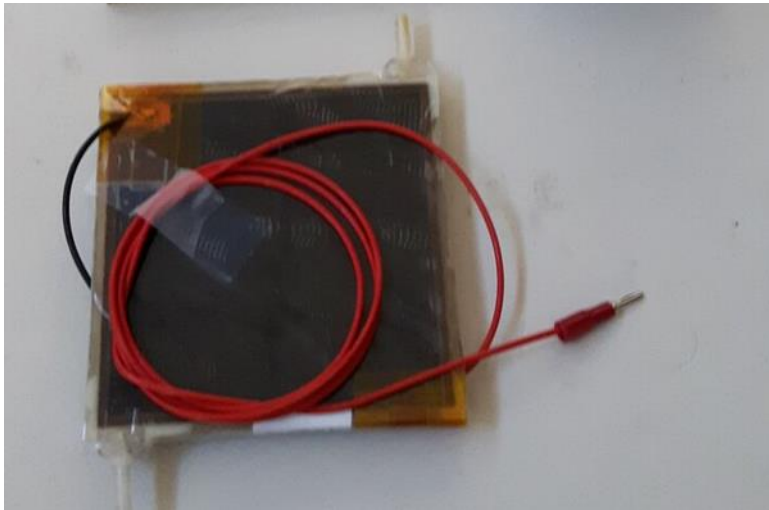

Prepare and test few small OPERA RPCS at the Gamma Irradiation Facility to study rate sustainability. Test period available in September thank to CMS availability

Complete the simulation studies to determine the expected flux and also investigate on possible reduction by means of proper shields

GIF++

Located at the H4 beam line in EHN1, it is a unique place where high energy charged particle beams (mainly muon beam with momentum up to 100 GeV/c) are combined with a 14 TBq $^{137}\text{Cesium}$ source.



OPERA RPCs towards SHiP ?

- OPERA RPCs are 2.9 m long and do not fit in the present geometry. A partial production of chambers is therefore unavoidable. Also a new geometry is being investigated which could result in a severe reduction of the needed detector surface (700 m²).
- OPERA RPCs were designed and built in year 2000. Their usage in 2023 would require proper conservation in temperature –humidity controlled stocking area. Even in safe environment, material aging effect over two decades needs to be evaluated.
- If avalanche operation mode is preferred, low resistivity electrodes shall be used for the chambers construction.

OPERA RPCs towards SHiP ?

- The use of new environment friendly gas mixture will be compulsory in the next years. This will might have an impact on the detector operation mode. Use of a standard LHC technology will result in a profitable collaboration towards a common solution.
- Massive R&D in avalanche on-going for LHC that can be applied to SHiP.
- Additional concept could be introduced if a new detector is designed: reduce strip width to achieve better spatial reconstruction with less layers; introduce calorimetric read-out for better muon identification with respect to electrons, Simulation will drive the discussion for those issues.



Production of new chambers should be envisaged

Large expertise exists in Italy for the detector production

→ Electrodes



→ Detectors

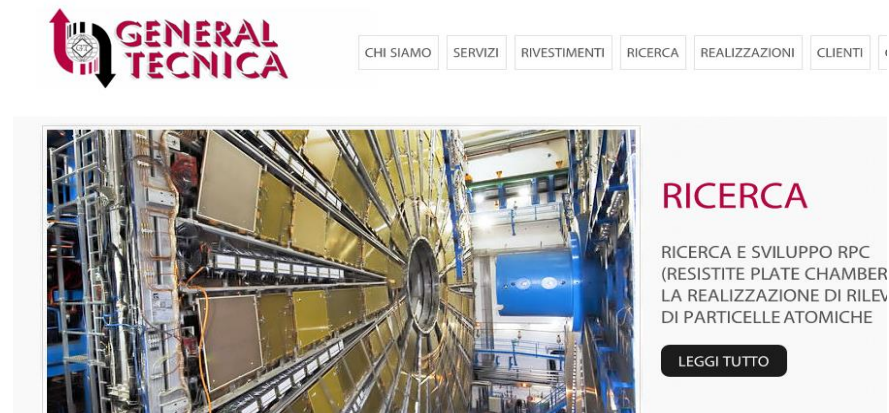

Also some CMS members have expressed interest in offering expertise for the SHiP project. To be consolidated in future with possible official involvement of institutions and FAs.



KODEL (Korea University)

KODEL has produced the RPCs for the forward part of CMS. They are quite active in the R&D for the next generation of RPCs. Willing to produce RPCs for SHiP.



IPLN LYON (France)

Lyon has proposed new glass RPCs for the CALICE digital hadron calorimeter. They are also studying new fast front-end board for position determination along the strip by means of time difference

Readout electronics for streamer mode operation developed in Bari

- Input: 64 channels , Discrimination of the signals by means of LVDS receivers, Zero suppression of the data, Time stamp of the data with a resolution of 10 ns
- Continuous transmission of the zero-suppressed data via the Ethernet 100 Mbit/s Interface with the UDP/IP protocol
- The readout system is structured in three levels: Front-End Board (FEB), Controller Board (CB) and Trigger Supervisor (TS)

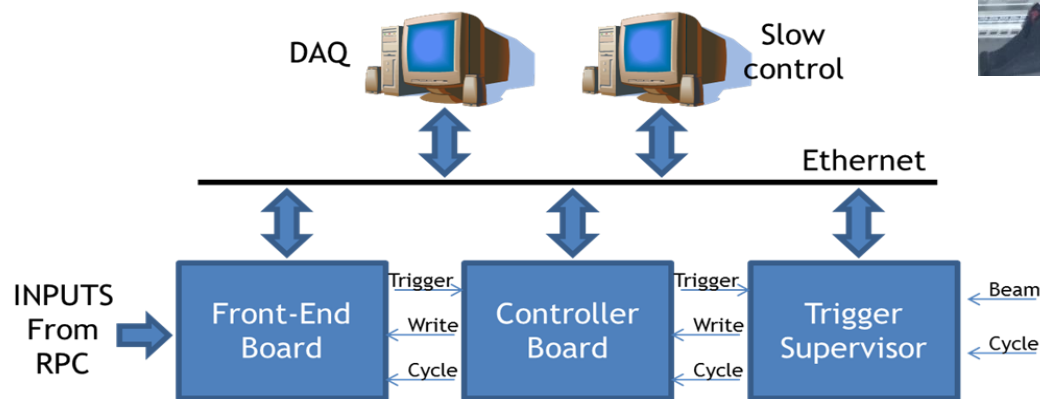

Readout electronics for avalanche mode operation

CMS chip (designed in 2000)

- 0.80 μm BiCMOS technology
- accepts only negative signals
- Gain: $\sim 2 \text{ mV/fC}$
- Power supply: + 5 V



$2 \cdot 10^5$ channel functioning in CMS

ALICE chip (designed in 2013)

- 0.35 μm CMOS technology
- accepts positive/ negative signals
- Gain: $\sim 1 \text{ mV/fC}$
- Power supply: + 3 V

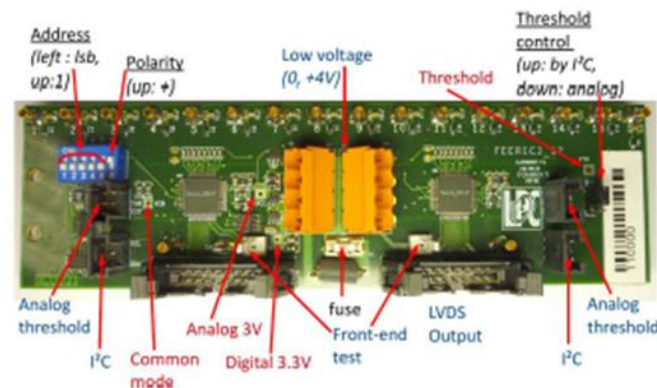



RPC test facility set up at LNF

Telescope with 12 chambers instrumented with the new FEBs developed in Bari

Results on spare OPERA RPCs

efficiency

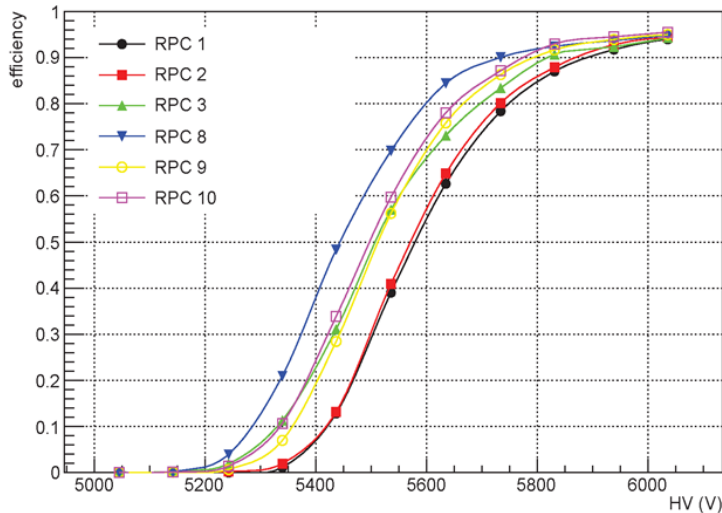

efficiency

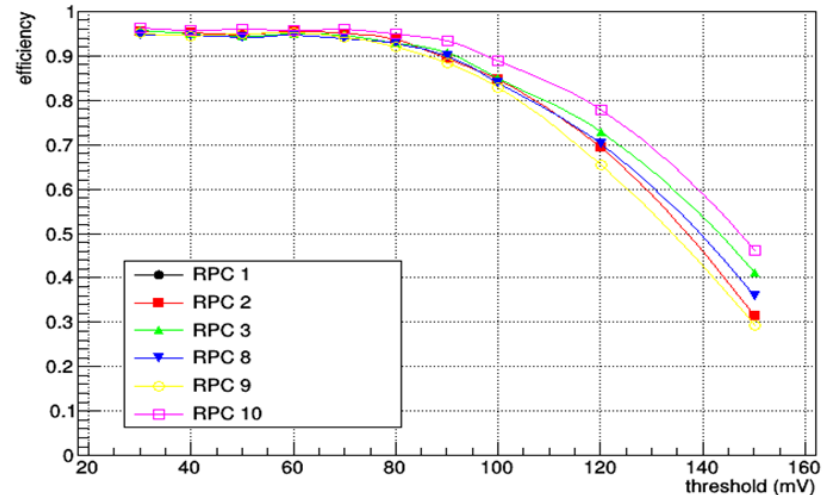

RPC test facility set up at LNF

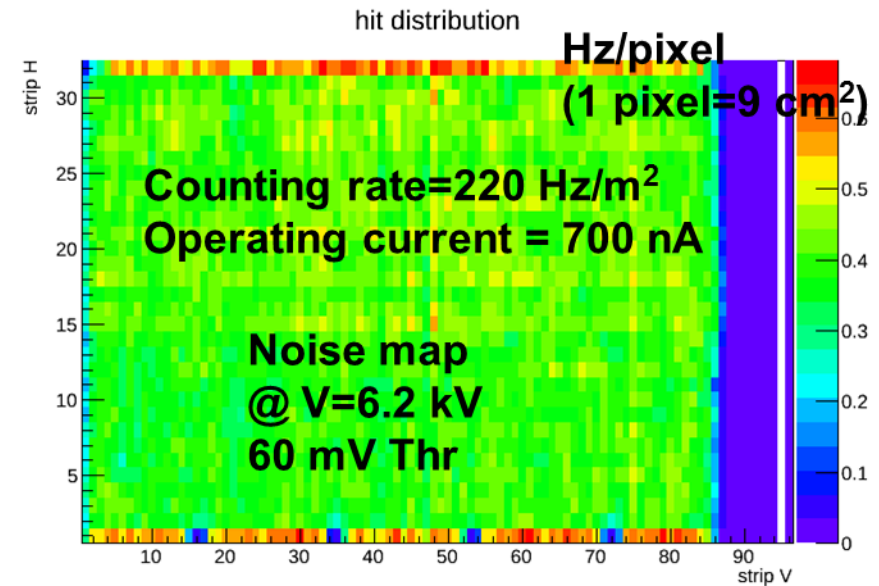
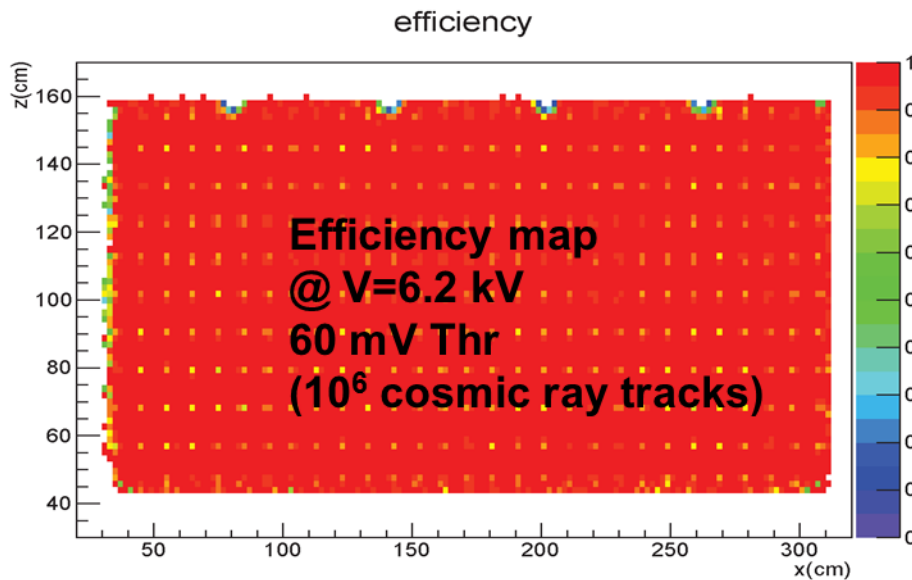

LNF facility can be used for further tests, also for new chambers in avalanche

Decommissioning of OPERA muon spectrometers



Few OPERA RPCs will be carefully extracted (end of June) and transported to LNF to assess performance at the test facility.

Streamer vs avalanche studies

Longevity studies

Gas mixtures studies

New generation RPCs (low resistivity electrodes) is most likely the best option for the SHiP muon spectrometer.

A novel design could catch-up the most recent developments and account for work-in-progress issues on which a larger community is engaged (gas mixture).

A new design could introduce innovative concept for the front-end and the read-out (calorimetry, X-Y read out with timing).

Large existing expertise could be exploited. Initiative to attract new institutions and secure proper funding to the project