

# Detector Simulation

Mihaly Novak  
CERN PH/SFT

# Foreword

This lecture is aimed to offer a **simple and general introduction** to detector simulation.

**Geant4** will be considered as a concrete example (because it is used by the LHC experiments) but only to illustrate general aspects of detector simulation.

This lecture is **not** a tutorial on Geant4 !

*(The best way to learn how to use any simulation package is by starting with an example)*

# Outline

## 1. Introduction

- Why do we need to simulate a detector?
- How does it work?

## 2. Geometry

- How do we describe an experimental apparatus?

## 3. Physics

- What is available and what to use?
- What are the challenges?

## 4. Validation

- How can we trust a few million lines of code?

# Introduction

# Introduction

- Simulation is a very useful, essential tool in modern particle physics for:
  - **designing an experiment** (e.g. now ILC/CLIC, FCC)
  - **analysing the data** (e.g. now LHC experiments)
- For the LHC experiments, the simulation is made of two distinct steps:
  1. **Simulation of the p-p collision**
    - Monte Carlo event generators
  - ➔ 2. **Simulation of the passage of the produced particles through the experimental apparatus**
    - Monte Carlo radiation transportation, or simply “detector simulation”
    - From the beam pipe to the end of the cavern
    - The output of 1. is the input of 2.

# Monte Carlo radiation transportation codes

- The simulation of the p-p collision is the same for different experiments at the same collider, e.g. ATLAS and CMS
- The detector simulation is different for each experiment. However, **general codes exist that can be used for simulating any detector**
  - An experimental apparatus can be modeled in terms of **elementary geometrical objects**
  - The **physics processes** are detector independent
- These general codes, e.g. Geant4, are called **“Monte Carlo radiation transportation codes”**
  - Non-deterministic (e.g. do not solve equations); use random numbers to reproduce distributions
  - Transport particles through matter

# How does it work?

- Treat one particle at the time
- Treat a particle in **steps**

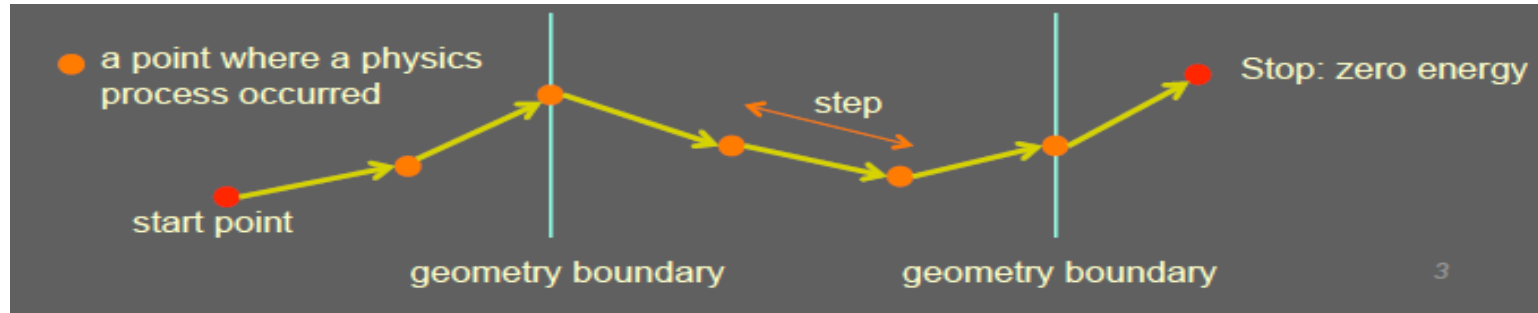

- For each step
  - the step length is determined by the cross sections of the physics processes and the geometrical boundaries; if new particles are created, add them to the list of particles to be transported;
  - local energy deposit; effect of magnetic and electric fields;
  - if the particle is destroyed by the interaction, or it reaches the end of the apparatus, or its energy is below a (tracking) threshold, then the simulation of this particle is over; else continue with another step.
- Output
  - new particles created (indirect)
  - **local energy deposits** throughout the detector (direct)

# Algorithm

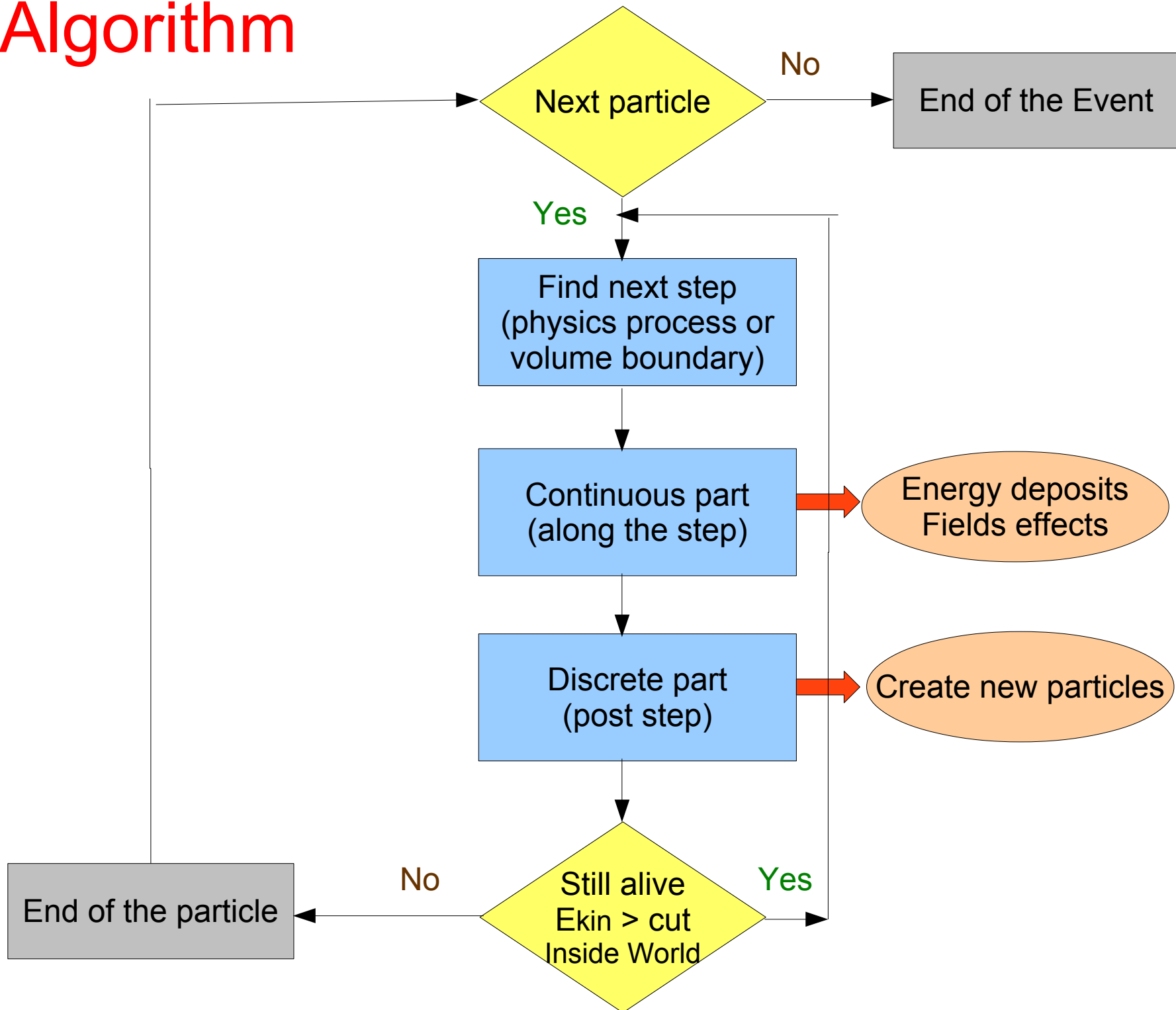



# “Digitization”

- Besides the geometry, another experiment-specific aspect of the detector simulation is the “digitization”
  - It is not part of the general radiation transportation codes
- It consists of producing the detector response in terms of **electric current & voltage signals**, as in the real experiment
  - The same reconstruction chain can be applied for both real and simulated data
- The general radiation transportation code provides **energy deposits** in the whole detector; from these, the “digitization” simulates the **electrical signals** induced in the **sensitive parts** of the detector
- Another detector-specific aspect is the “**pile-up**” ...

# Accuracy vs. Speed

- Huge samples (billions) of simulated events are needed by the experiments for their physics analyses
- The number of simulated events is **limited by CPU**
- The simulation time is **dominated by the detector simulation**
- **Tradeoff between accuracy and speed** of the detector simulation
  - More precise physics models are slower and, more importantly, create more secondaries and/or steps
  - Smaller geometrical details slow down the simulation
    - Never model explicitly screws, bolts, cables, etc.
  - Continuous spectrum of types of detector simulations
    - From full, detailed detector simulations (covered in this lecture)
    - To very fast, fully parametrized detector simulations (not covered here!)
- *On-going effort to exploit the latest CPU features*
  - *Multi-threading (e.g. G4 10) ; Vectorization (e.g. Geant-V)*

# Application domains

- We are considering here mainly **high-energy physics**, but...
- There are other domains where the same radiation transportation codes are successfully used:
  - **Nuclear physics**
  - **Accelerator science**
  - **Astrophysics**
  - **Space engineering**
  - **Radiation damage**
  - **Medical physics**
  - **Industrial applications**
- So, detector simulation is a **multi-disciplinary** field!

# Geometry

# Geometry

- The way to describe the geometry varies widely between the different simulation engines
  - In Geant4, you need to write some C++ code
    - Geometry objects are instances of classes
    - Geometry parameters (e.g. dimensions) are arguments of the constructors
- The geometry can be “flat” or “hierarchical”
  - In Geant4, it is hierarchical: a volume is placed in its mother volume; there are mother-daughter relationships
- A **material** should be assigned to each volume

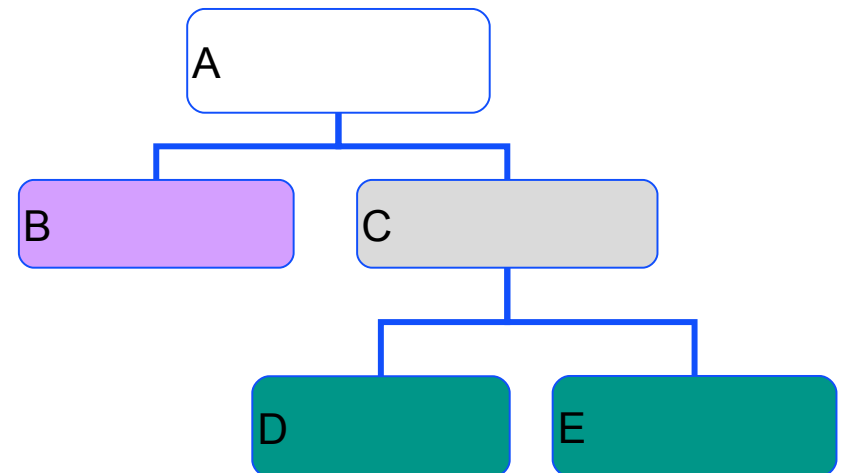
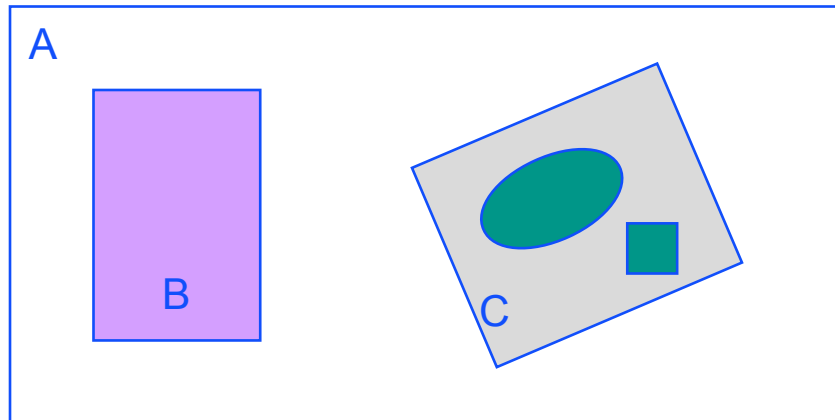

# CGS (Constructed Geometry) Solids

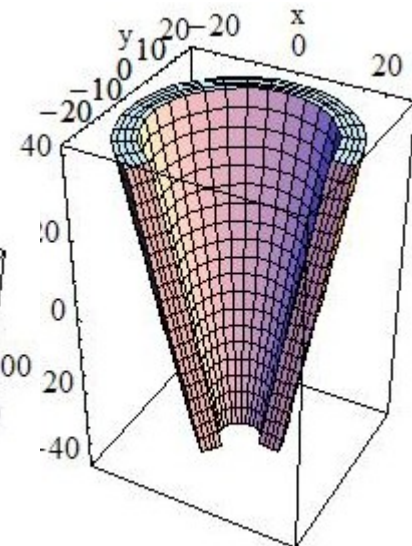
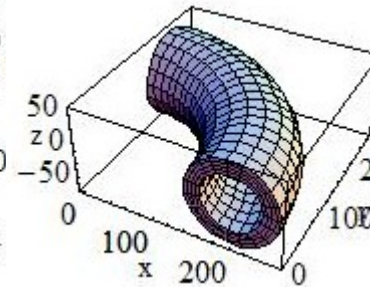
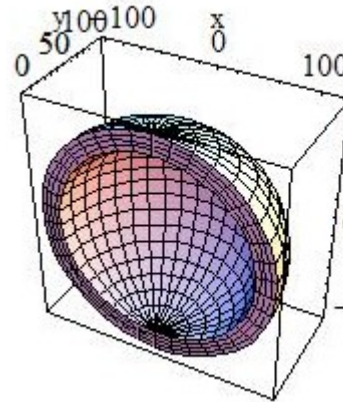
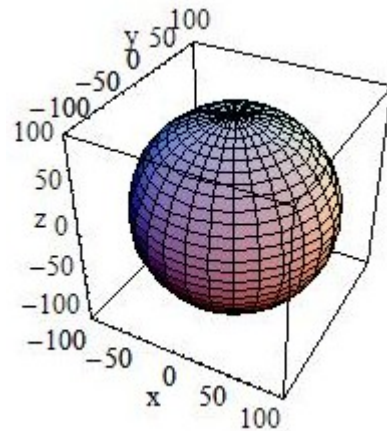
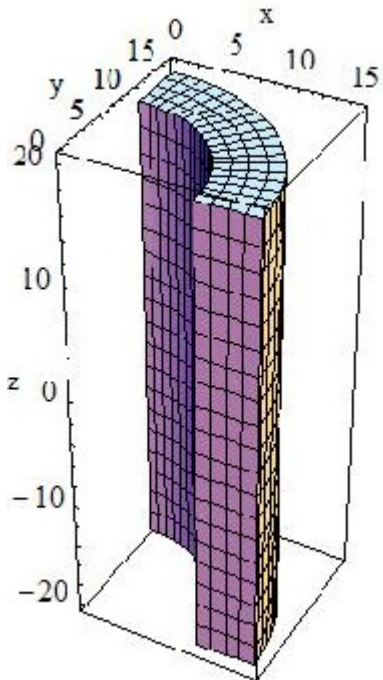
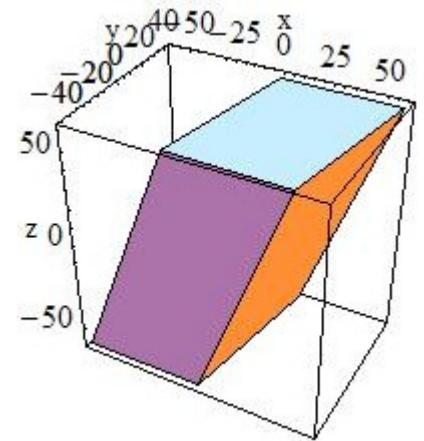
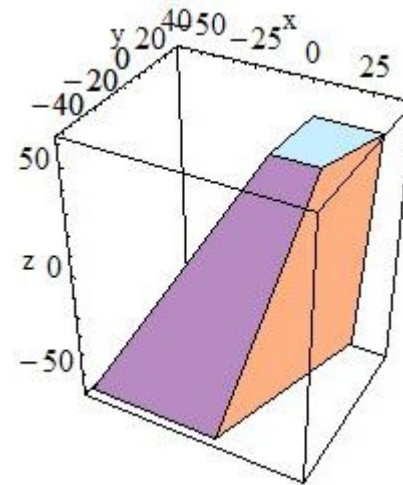
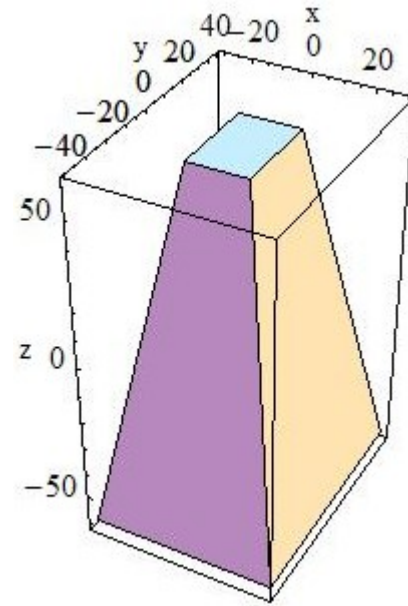
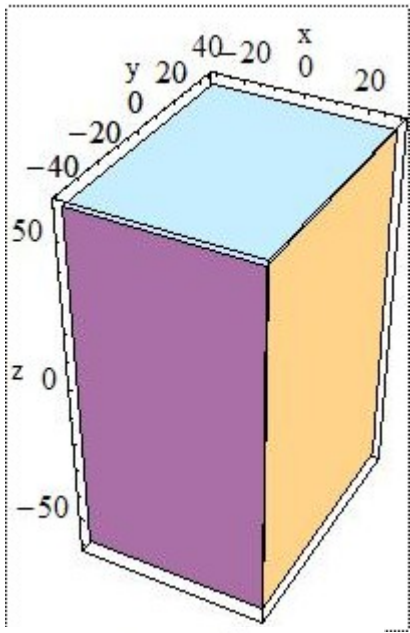

# Other CGS solids

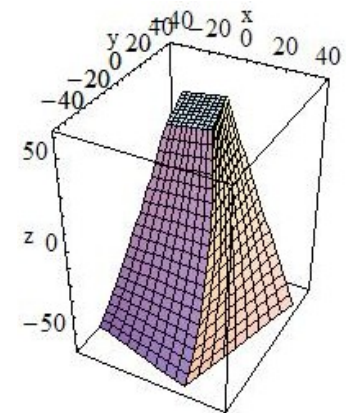
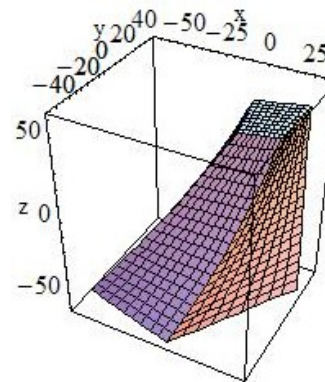
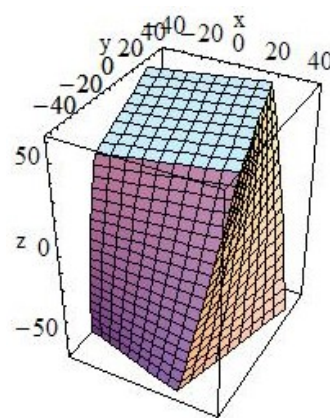
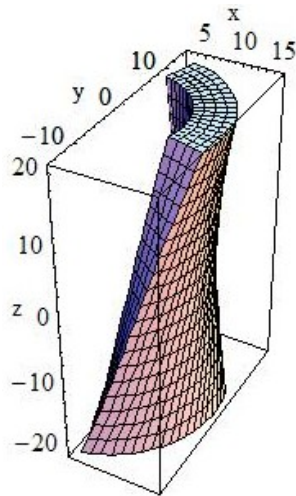
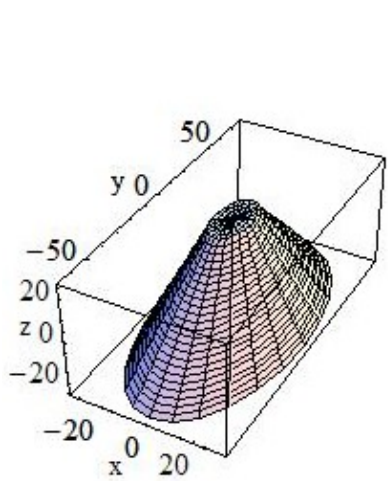
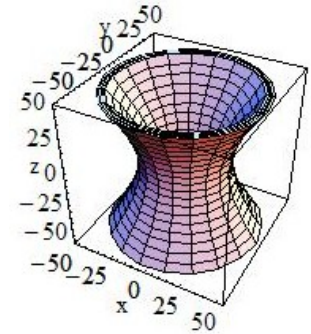
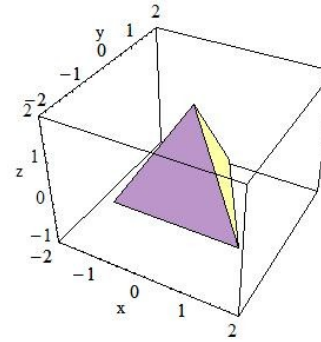
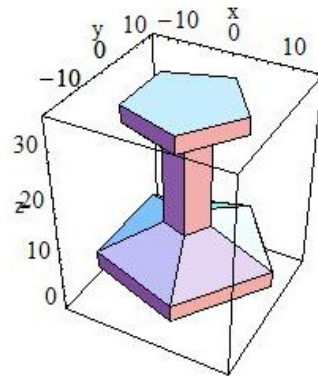
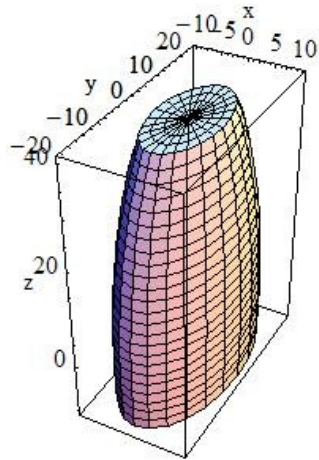
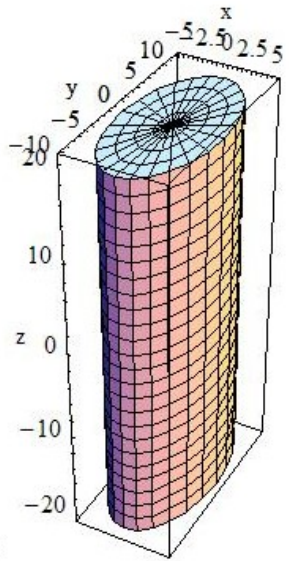

# Boolean solids

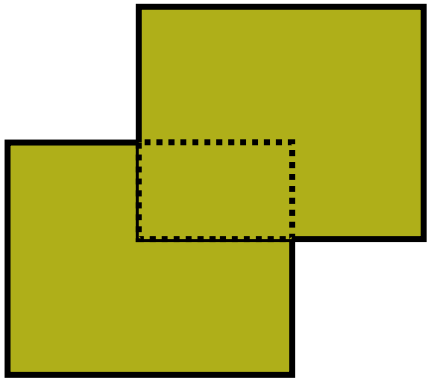

Union

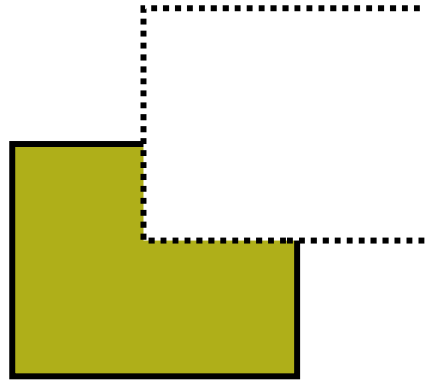

Subtraction

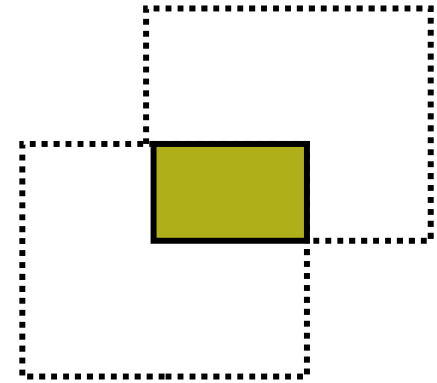

Intersection

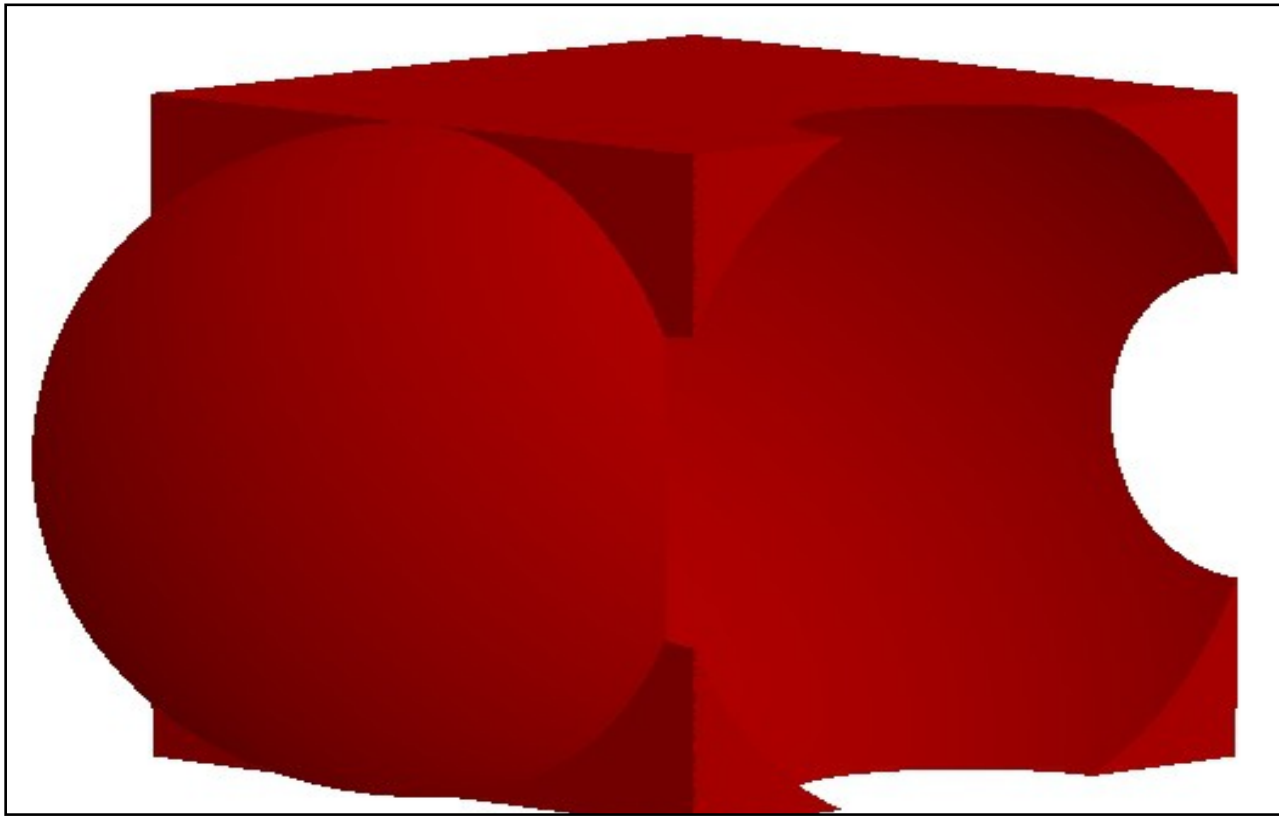



# Geometrical symmetries

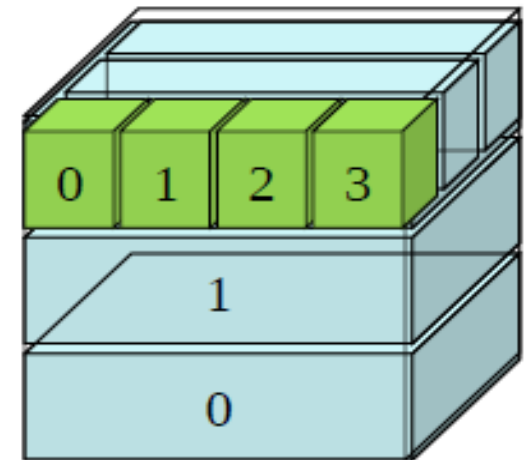
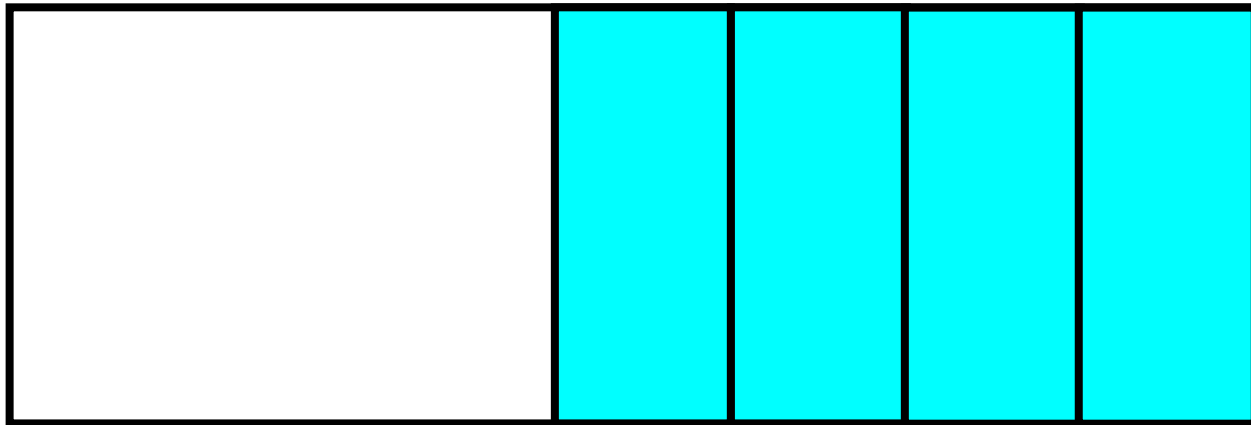
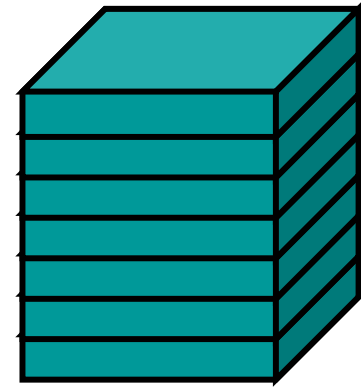
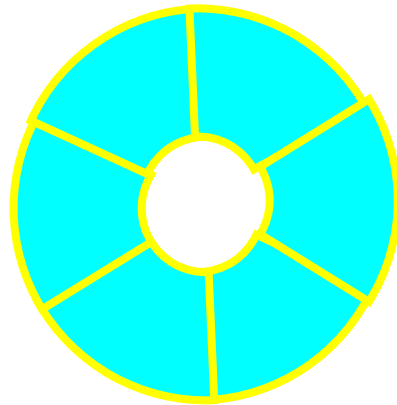
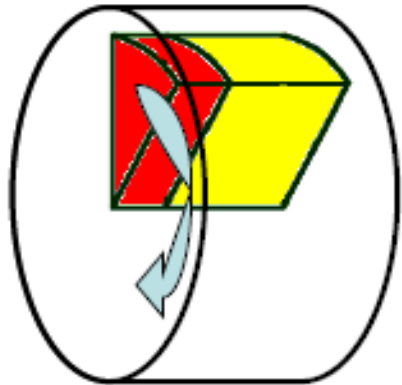

# Space applications

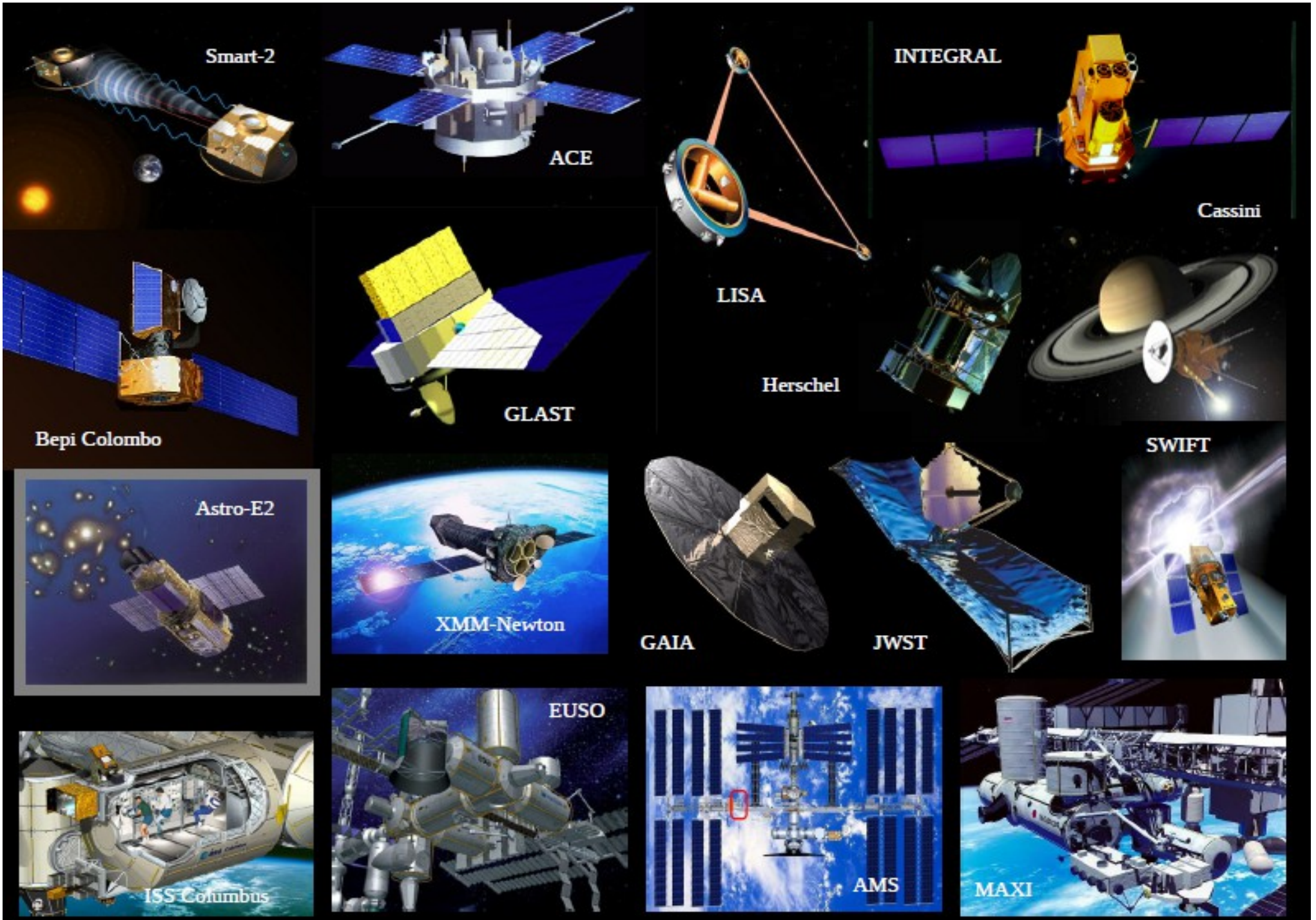

# Medical applications

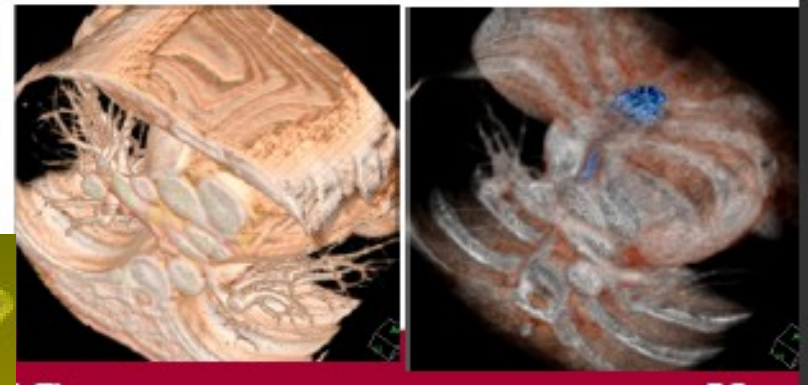
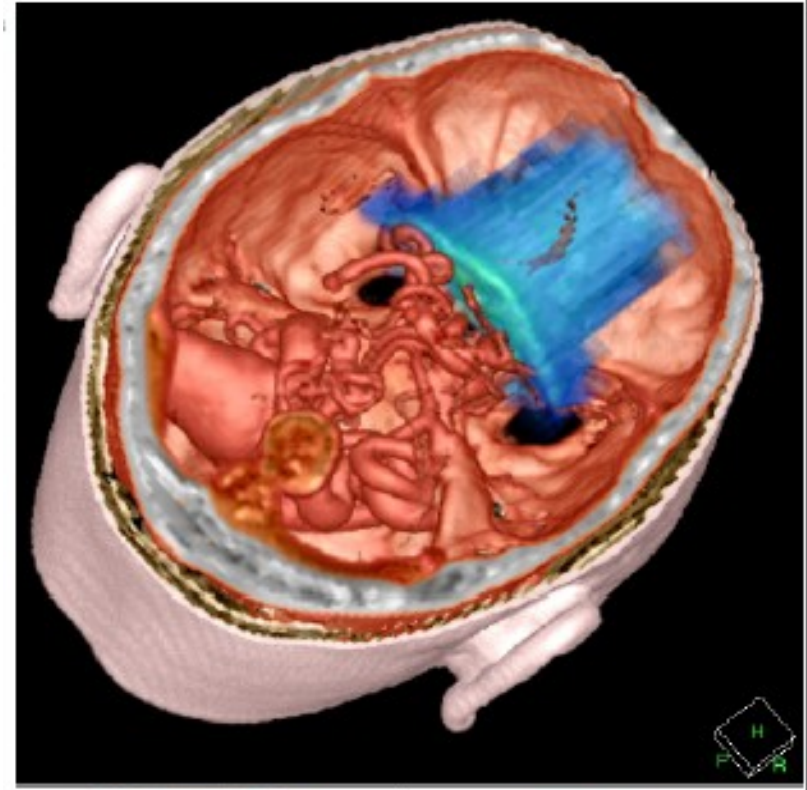
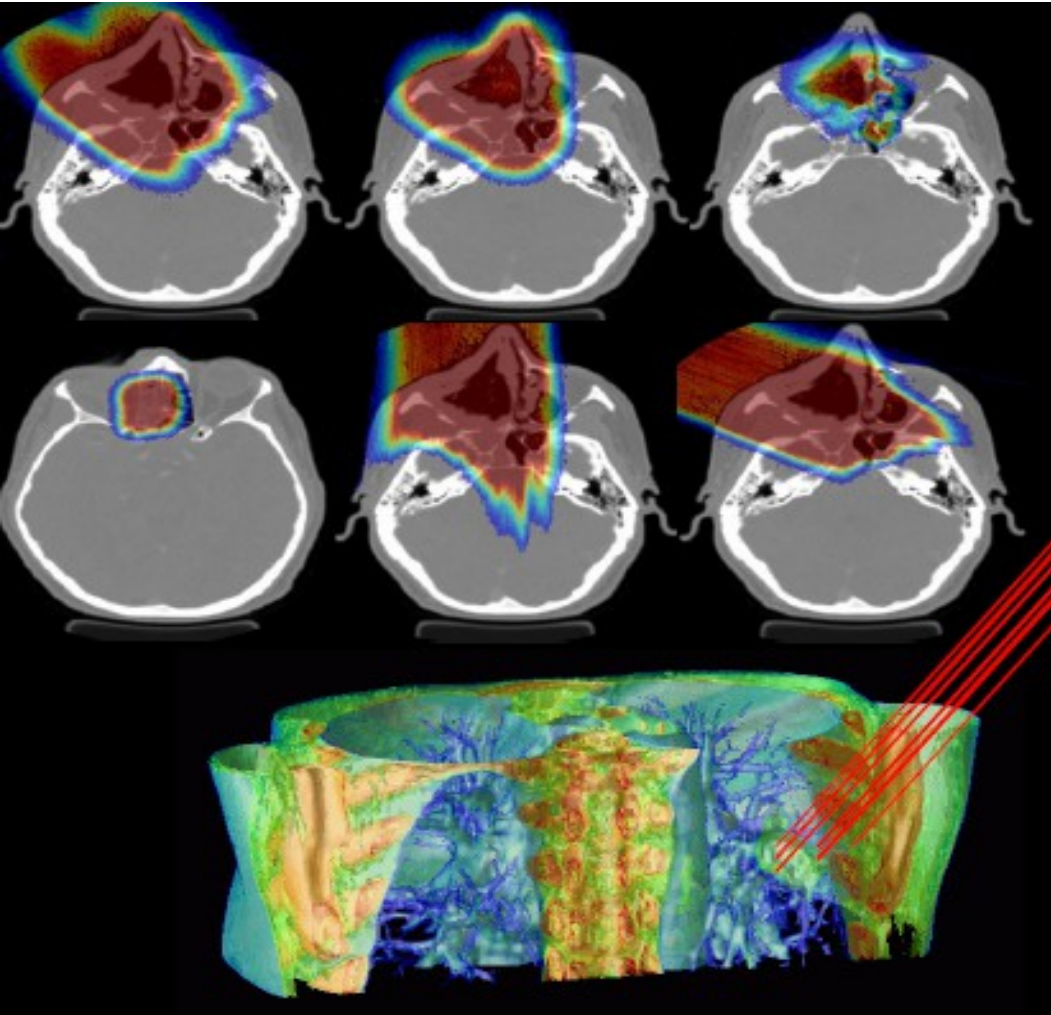

# HEP : CMS tracker

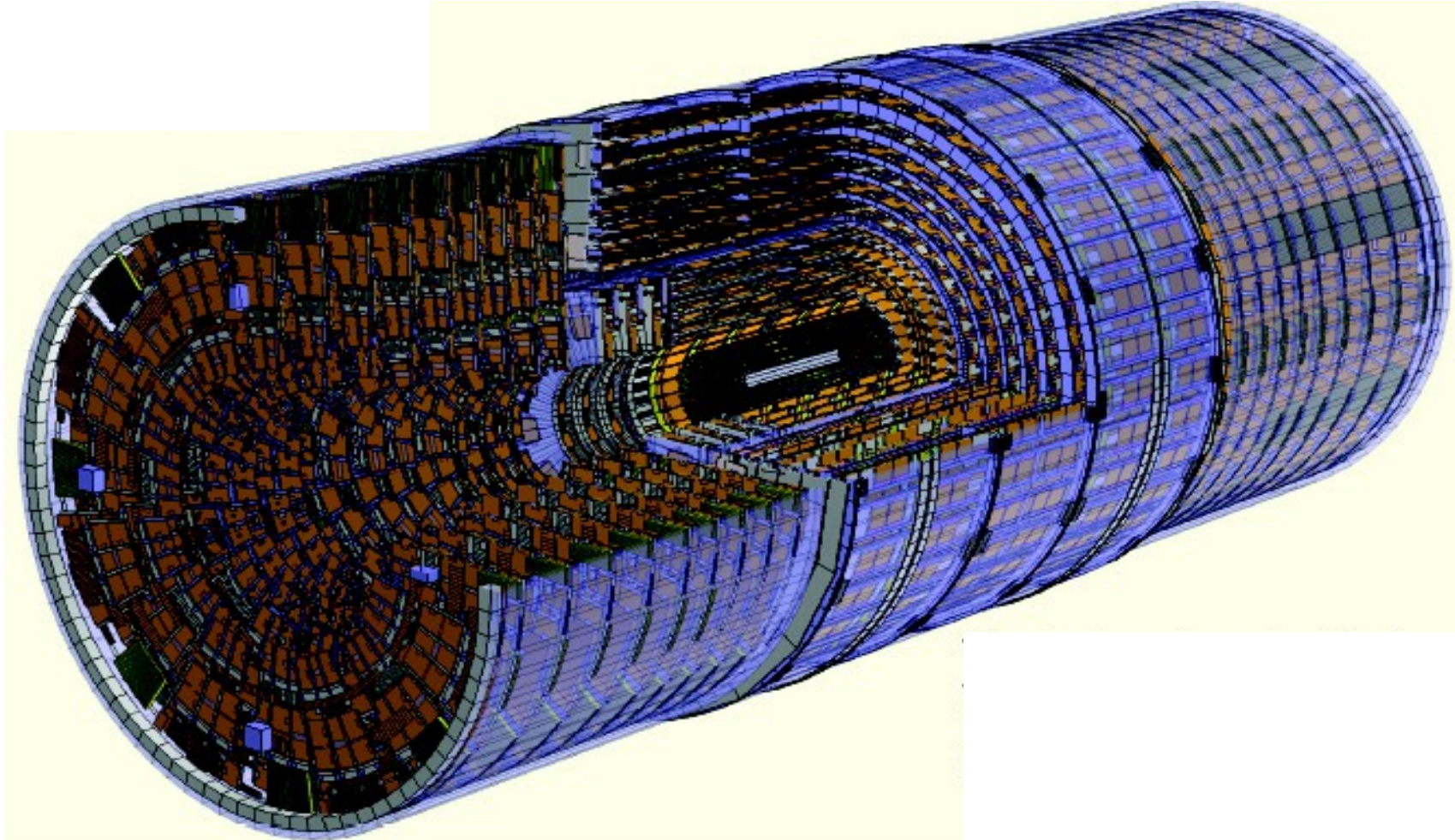

# HEP : ATLAS

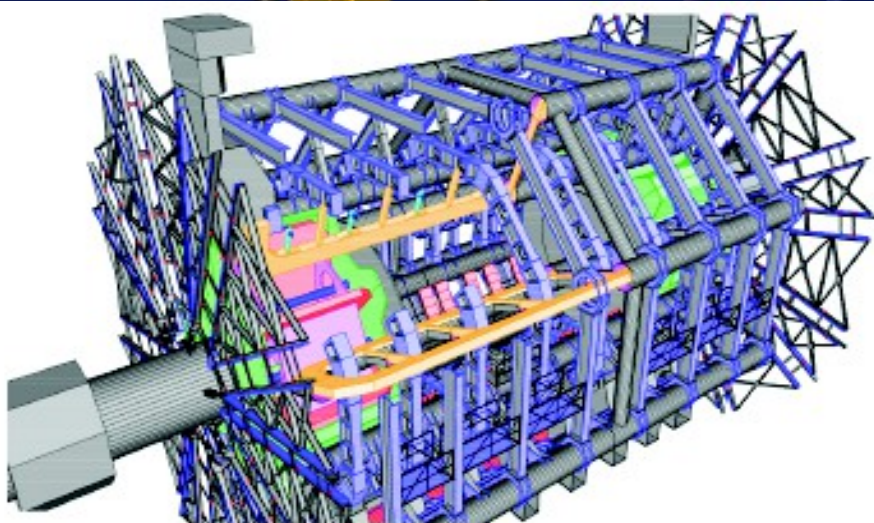
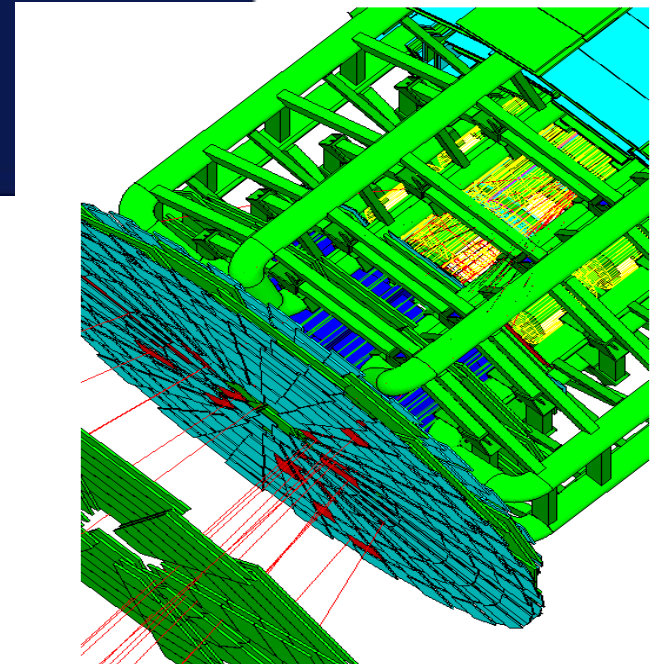
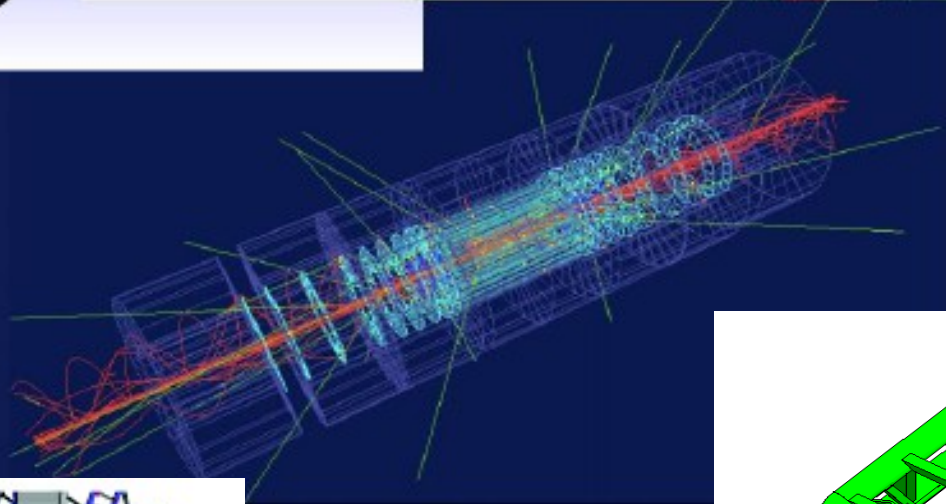
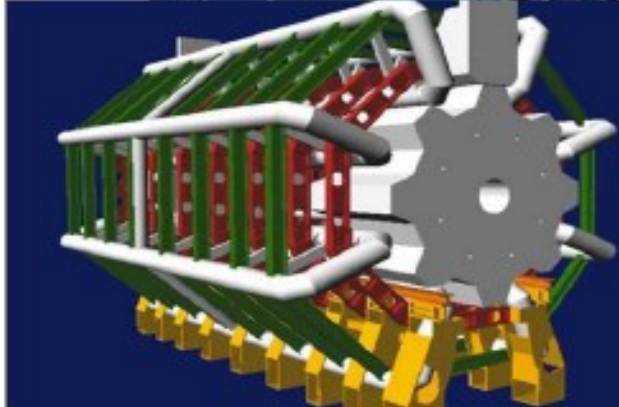
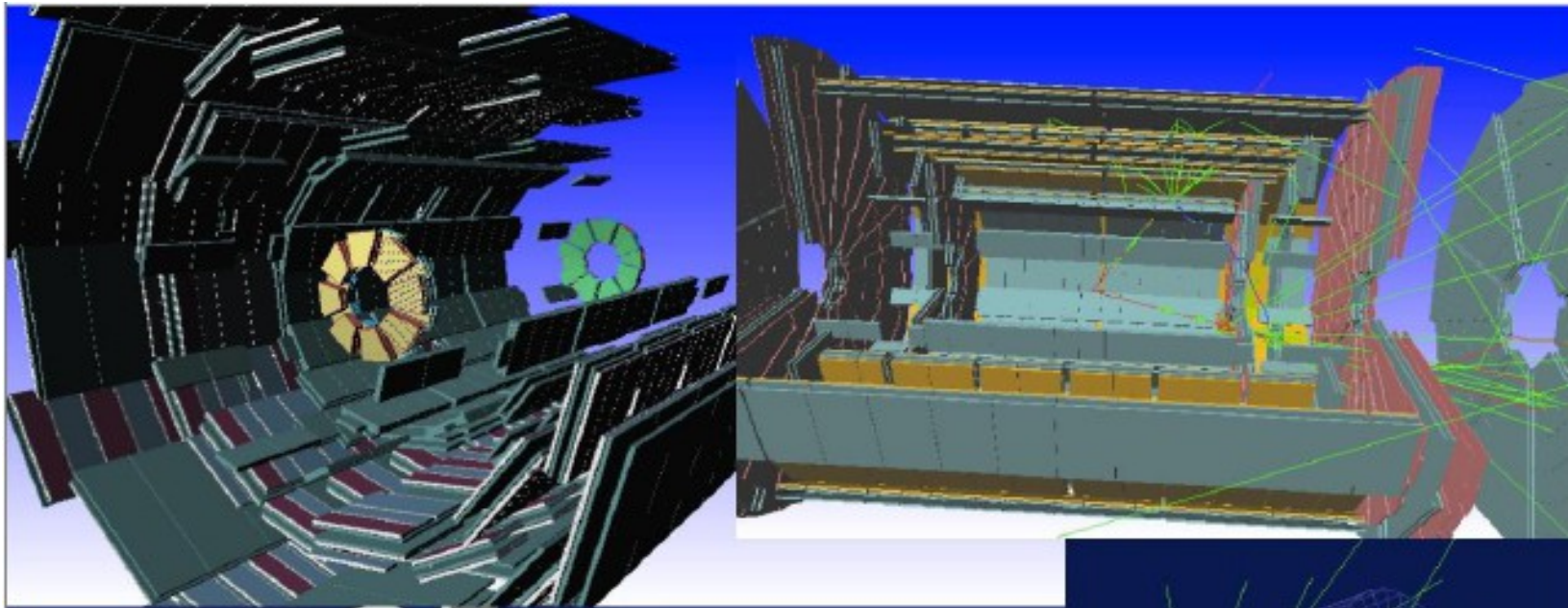

# Physics

# Particle interactions

Each particle type has its own set of physics processes.  
Only **electromagnetic effects** are directly measurable

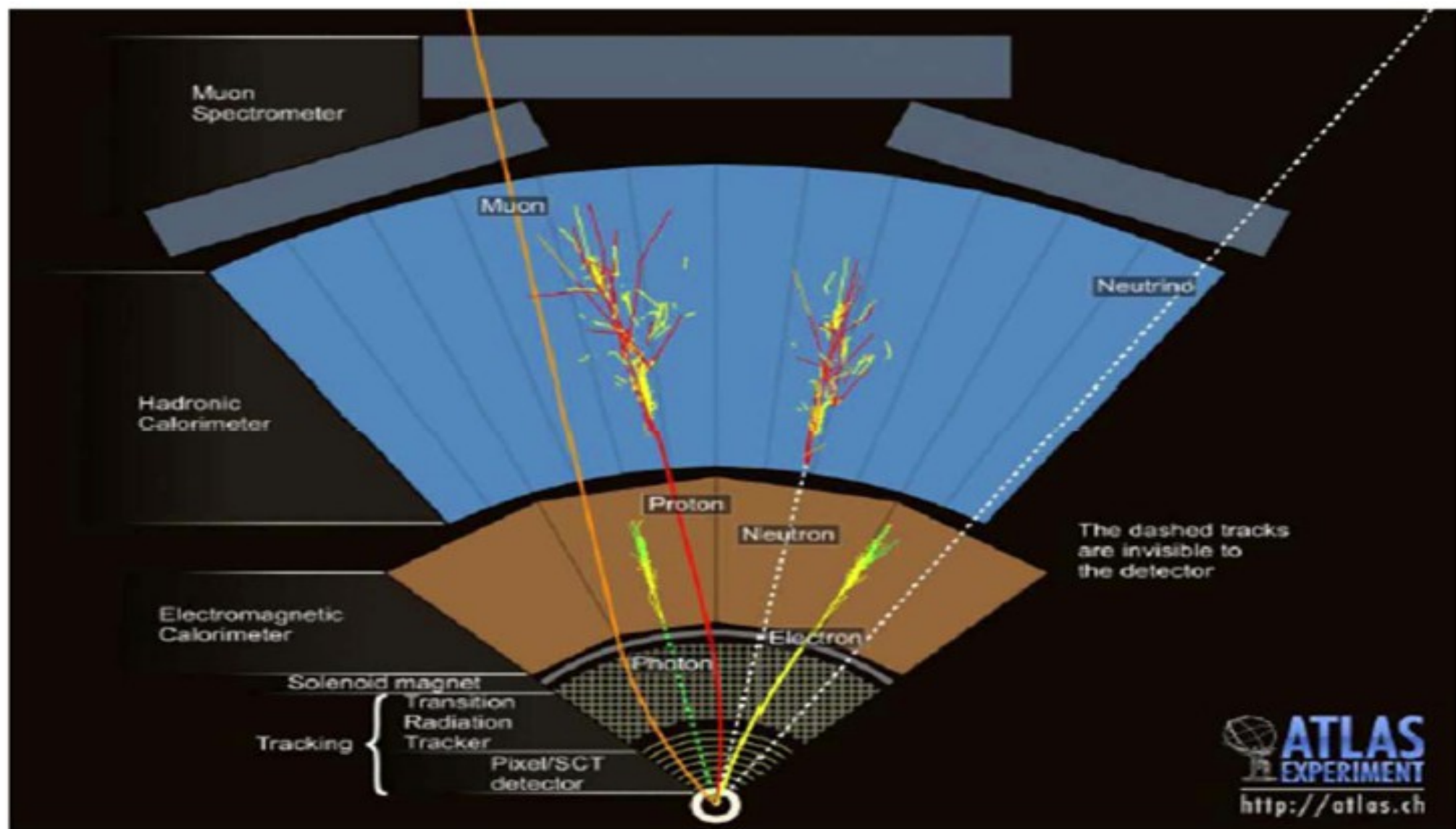

# Main electromagnetic processes

## Gamma

- Conversion  
 $\gamma \rightarrow e^+ e^- , \mu^+ \mu^-$
- Compton scattering  
 $\gamma \text{ (atomic)} e^- \rightarrow \gamma \text{ (free)} e^-$
- Photo-electric  
 $\gamma \text{ material} \rightarrow \text{(free)} e^-$
- Rayleigh scattering  
 $\gamma \text{ atom} \rightarrow \gamma \text{ atom}$

## Muon

- Pair production  
 $\mu^- \text{ atom} \rightarrow \mu^- e^+ e^-$
- Bremsstrahlung  
 $\mu^- \text{ atom} \rightarrow \mu^- \gamma$
- MSC (Coulomb scattering)  
 $\mu^- \text{ atom} \rightarrow \mu^- \text{ atom}$
- Ionization :  
 $\mu^- \text{ atom} \rightarrow \mu^- \text{ ion}^+ e^-$

Total cross section:  
→ step length

Differential & partial  
cross sections :  
→ final state  
(multiplicity & spectra)

## Electron, Positron

- Bremsstrahlung  
 $e^- \text{ atom} \rightarrow e^- \gamma$
- MSC (Coulomb scattering)  
 $e^- \text{ atom} \rightarrow e^- \text{ atom}$
- Ionization  
 $e^- \text{ atom} \rightarrow e^- \text{ ion}^+ e^-$
- Positron annihilation  
 $e^+ e^- \rightarrow \gamma \gamma$

## Charged hadron, ion

- Bremsstrahlung  
 $h^- \text{ atom} \rightarrow h^- \gamma$
- MSC (Coulomb scattering)  
 $h^- \text{ atom} \rightarrow h^- \text{ atom}$
- Ionization  
 $h^- \text{ atom} \rightarrow h^- \text{ ion}^+ e^-$



# Production and tracking cuts

- **Ionization & bremsstrahlung** processes produce an increasing number of secondaries as the secondary energy decreases, so we need to set a **production cut**
  - Above the cut, new particles ( $e^-$ ,  $\gamma$ ) are created
  - Below the cut, “**continuous**” **energy loss** of the primary
- Once a charged particle is created, it can be reliably transported down to  **$E_{kin} \sim 1 \text{ keV}$** 
  - Either, stop it below a **tracking cut** and deposit its energy locally
  - Or, go down to  $E_{kin} \rightarrow 0$  using its approximated range
- Production and tracking cuts can be expressed directly as **kinetic energy thresholds** or indirectly as equivalent **range thresholds**

# Multiple (Coulomb) scattering (MSC)

- Charged particles traversing a finite thickness of matter suffer a huge number (millions) of elastic Coulomb scatterings
- The cumulative effect of these small angle scatterings is mainly a net deflection from the original particle direction
- In most cases, to save CPU time, these **multiple scatterings are not simulated individually, but in a “condensed” form**
- Various algorithms exist, and new ones under development. One of the main differences between codes

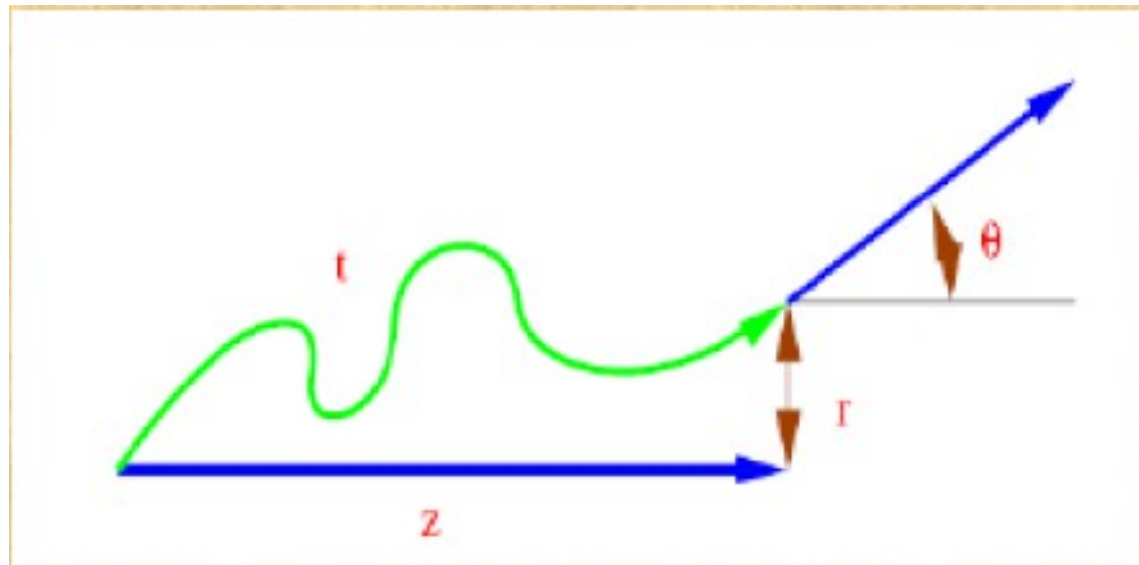

# Electromagnetic physics

- Typical validity of electromagnetic physics  $\geq 1$  keV ;  
for a few processes, extensions to lower energies
- CPU performance of electromagnetic physics is critical :  
continuous effort to improve it
- Detailed validation of electromagnetic physics is necessary  
before the validation of hadronic physics
- Typical precision in electromagnetic physics is  $\sim 1\%$ 
  - QED is extremely precise for elementary processes,  
but atomic and medium effects, important for detector simulations,  
bring larger uncertainties...
  - Moreover, the “condensed” description of multiple scattering  
introduces further approximations...
  - Continuous effort to improve the models

# Hadronic physics

- Hadrons ( $\pi^\pm$ ,  $K^\pm$ ,  $K^0_L$ ,  $p$ ,  $n$ ,  $\alpha$ , *etc.*), produced in jets and decays, traverse the detectors (H, C, Ar, Si, Al, Fe, Cu, W, Pb...)
- Therefore we need to model **hadronic interactions**  
**hadron – nucleus  $\rightarrow$  anything**  
in our detector simulations
- In principle, QCD is the theory that describes all hadronic interactions; in practice, perturbative calculations are applicable only in a tiny (but important!) phase-space region
  - the hard scattering at high transverse momentumwhereas for the rest, i.e. most of the phase space
  - soft scattering, re-scattering, hadronization, nucleus de-excitation  
**only approximate models are available**
- **Hadronic models are valid for limited combinations of**
  - **particle type - energy - target material**

# Hadronic models available in Geant4

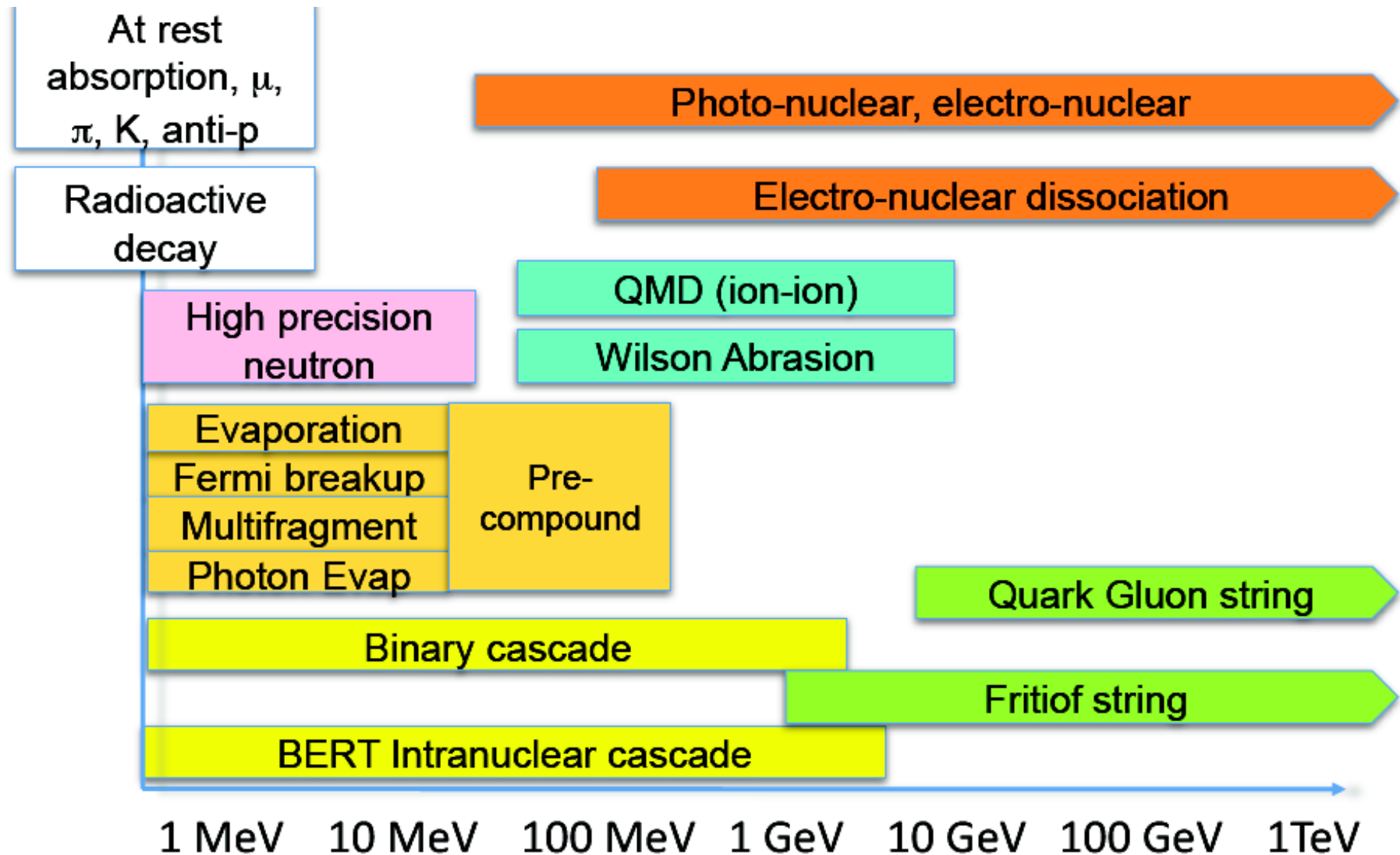

# Physics configuration

- No “unified” hadronic model: need to choose a set of hadronic models able to cover all possible interactions
  - The choice depends on the use-case, because of:
    - The energy scale involved
    - The compromise between accuracy and CPU speed
  - The choice is often done by the developers
    - Options can be proposed according to use-cases
- In the case of Geant4
  - These physics configurations are called “physics lists”
    - The particles to be considered in the simulation are also specified
  - There is no default
  - Ready-to-use “physics lists” exist, for different use-cases
  - Users can also tailor/modify any of these, or write their own

# Hadronic Interactions from TeV to meV

String model

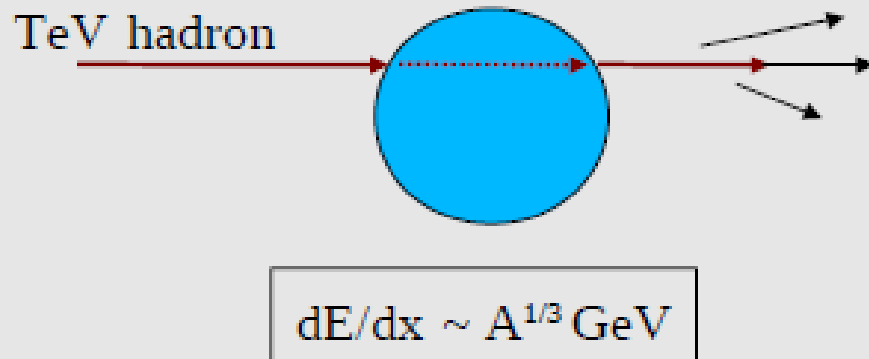

Intra-nuclear cascade model

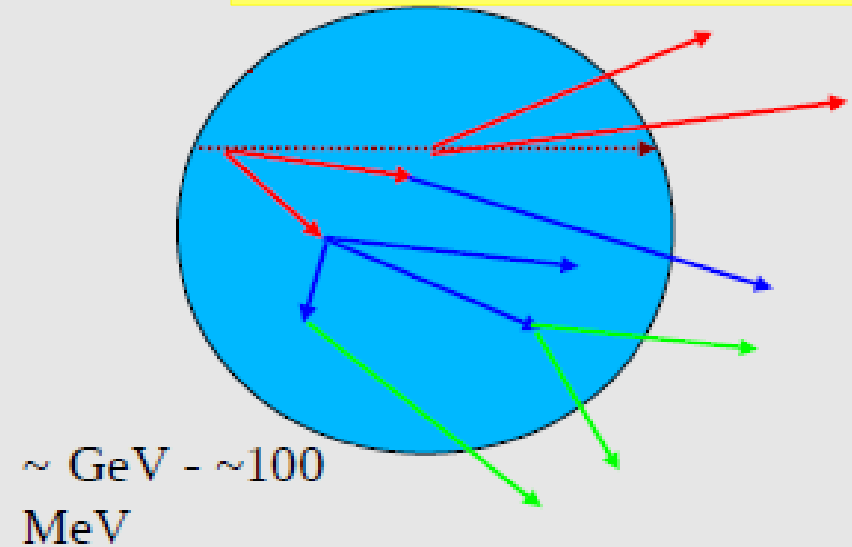

$\sim 100 \text{ MeV} - \sim 10 \text{ MeV}$

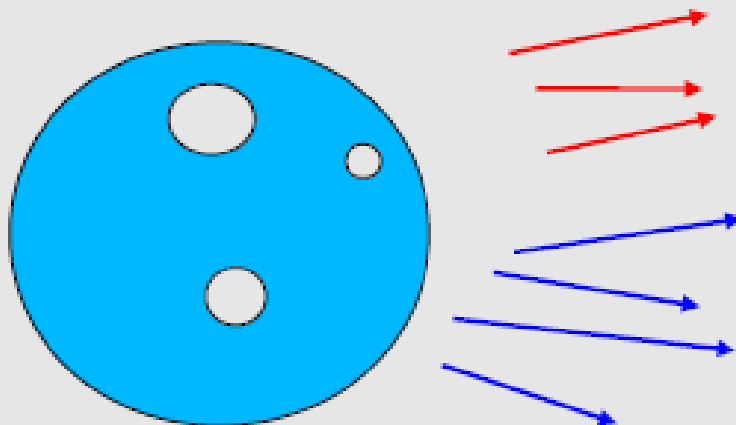

Pre-equilibrium (Precompound) model

$\sim 10 \text{ MeV}$  to thermal

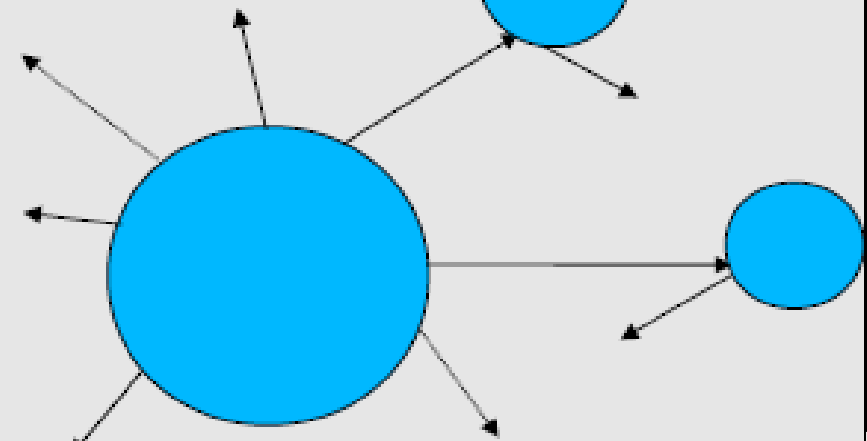

Equilibrium (Evaporation) model

# An interesting complication: Neutrons

- Neutrons are abundantly produced
  - Mostly “soft” neutrons, produced by the de-excitations of nuclei, after hadron-nucleus interactions
  - It is typically the 3<sup>rd</sup> most produced particle (after e<sup>-</sup>,  $\gamma$ )
- Before a neutron “disappears” via an inelastic interaction, it can have many **elastic scatterings** with nuclei, and eventually it can “thermalize” in the environment
- The CPU time of the detector simulation can vary by an order of magnitude according to the physical accuracy of the **neutron transportation simulation**
  - For typical high-energy applications, a simple treatment is enough (luckily!)
  - For activation and radiation damage studies, a more precise, **data-driven and isotope-specific** treatment is needed, especially for neutrons of kinetic energy **below ~ MeV**



# Hadronic showers

- A single hadron impinging on a large block of matter (e.g. a calorimeter) produces secondary hadrons of lower energies, which in turn can produce other hadrons, and so on: the set of these particles is called a **hadronic shower**
  - $e^-/e^+/\gamma$  (electromagnetic component) are also produced copiously because of  $\pi^0 \rightarrow \gamma \gamma$  and ionization of charged particles
- The development of a hadronic shower involves **many energy scales, from hundreds of GeV down to thermal energies**

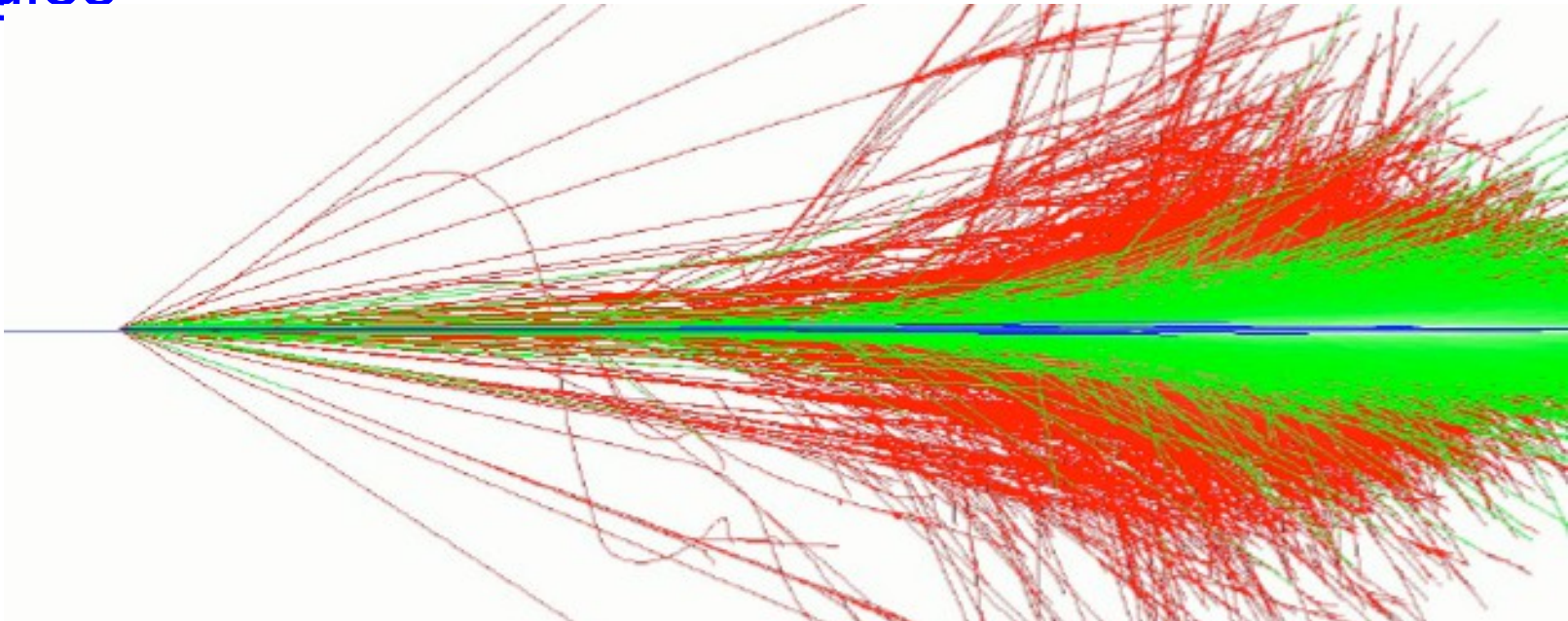

# Validation

# Multiple (Coulomb) scattering of electrons

Angular distribution of  $E_p = 15.7 \text{ MeV } e^-$  transmitted Au  $19.296 \mu\text{m}$

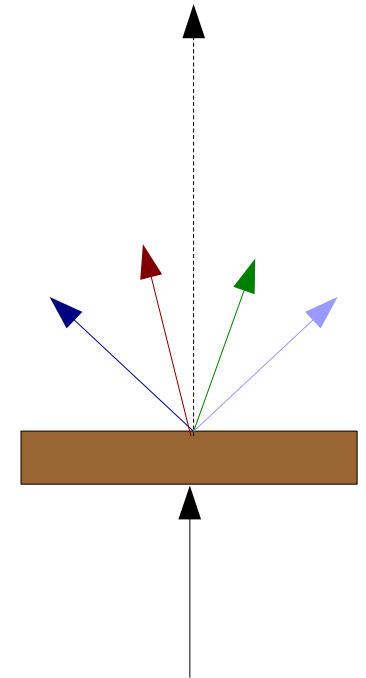
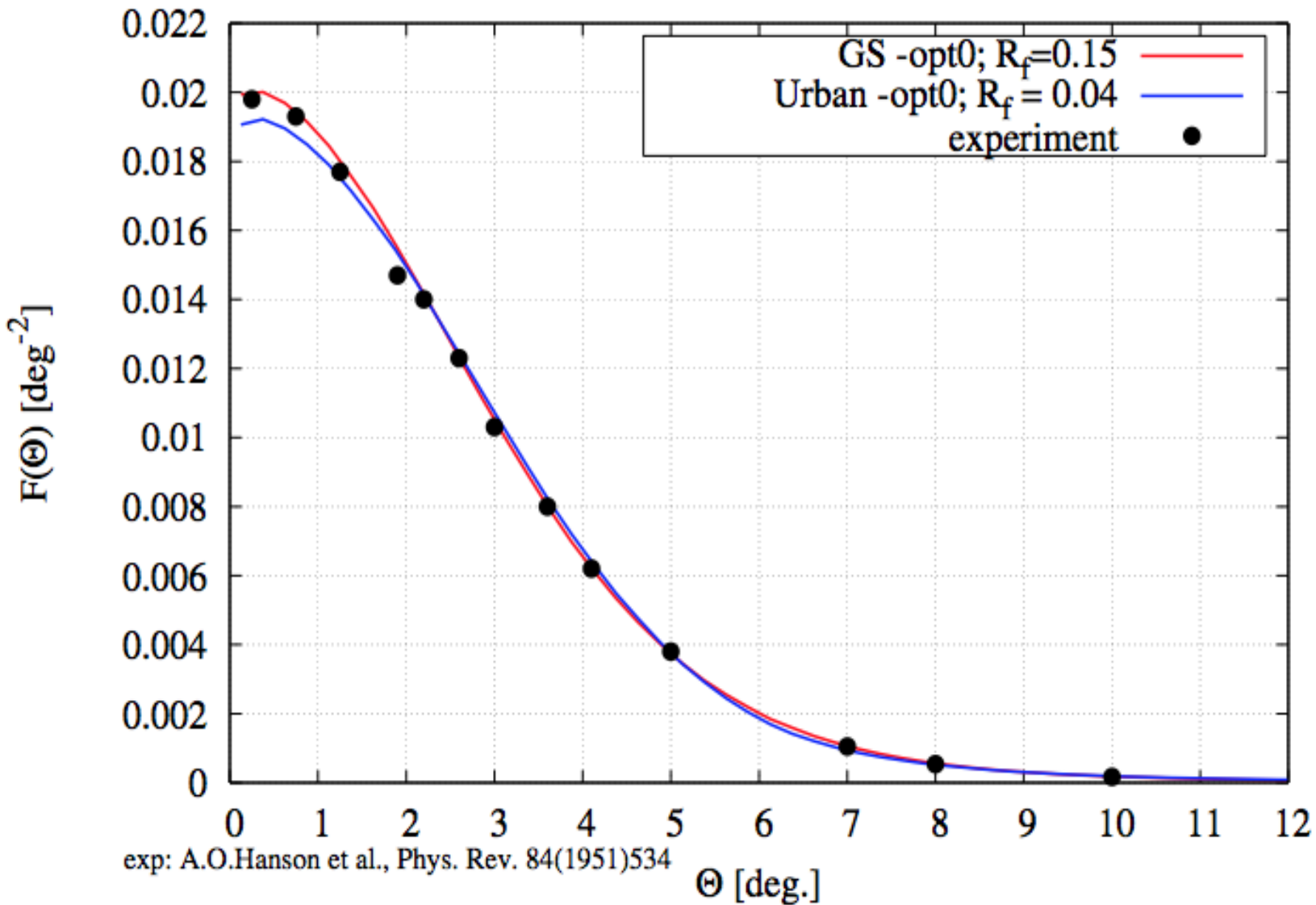

# Electron energy deposit

$e^-$  1.0 MeV in Ta, Geant4 10.2ref05

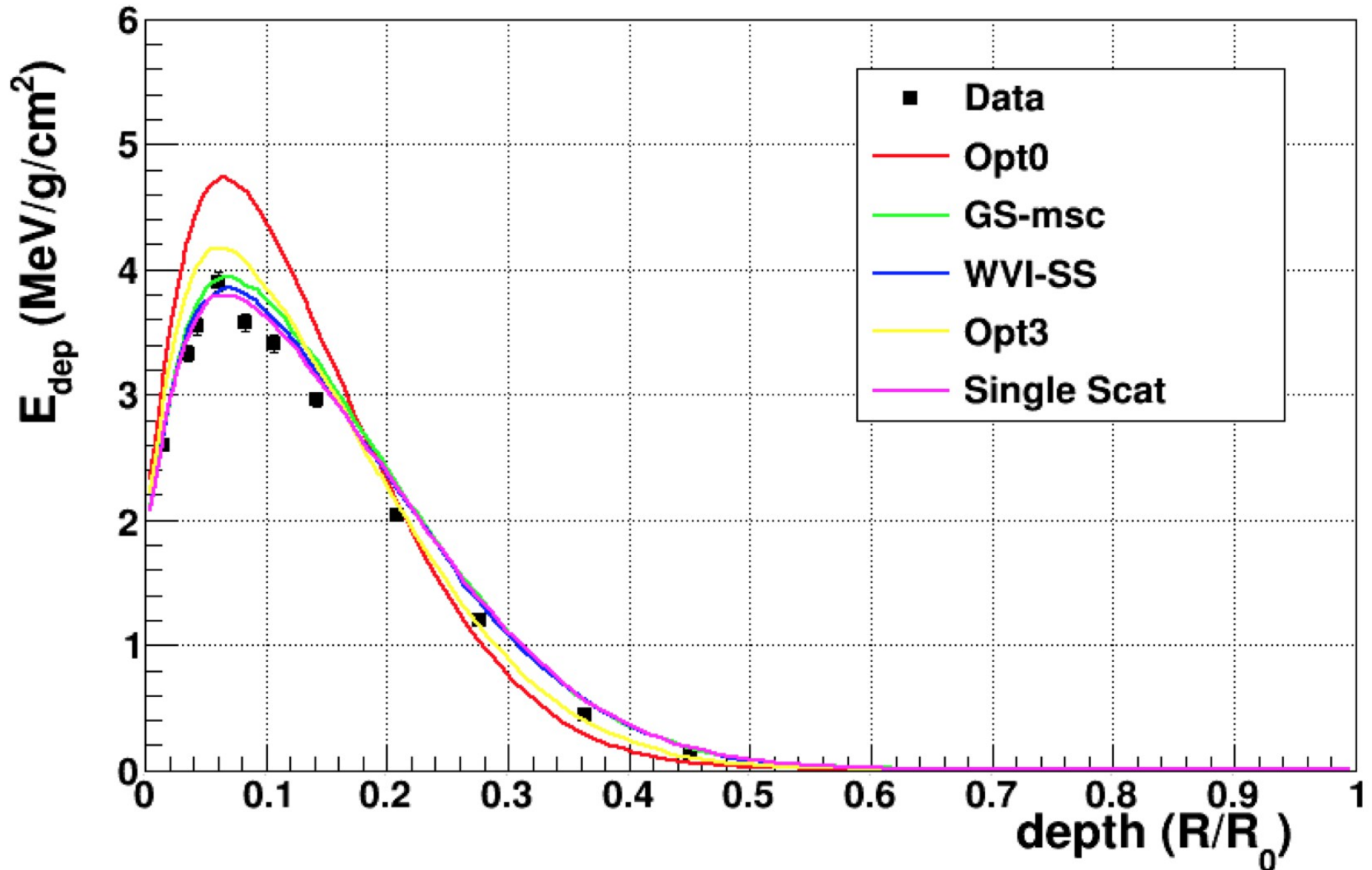

# Validation & tuning of hadronic models

- The developers of the hadronic models are responsible of the tuning & validation of these models with **thin-target (microscopic, single-interaction)** measurements

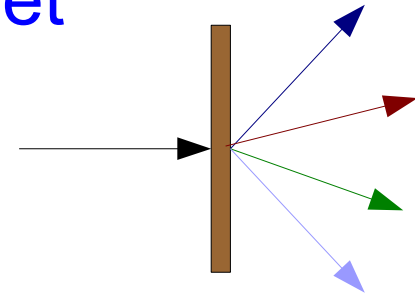

- Validation of complete physics configurations is performed by users mostly via measurements of **hadronic showers in calorimeter test-beam setups (thick targets)**

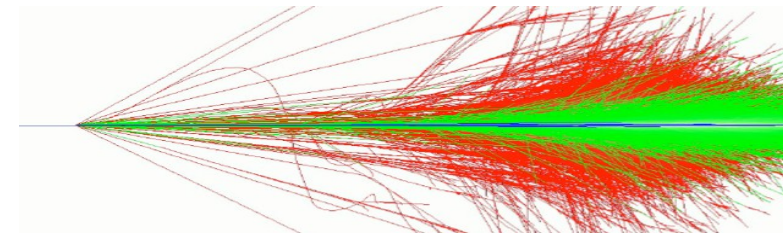

- The most important application of the hadronic models for collider experiments is the **simulation of jets**, which involves
  1. the Monte Carlo event generator
  2. the convolution of the showers for each constituent hadron
  3. experiment specific: geometry & materials, digitization, etc.

# Model-level thin-target tests

FTF Results at 400 GeV/c  
 $p \text{ Ta} \rightarrow \pi^+ X$

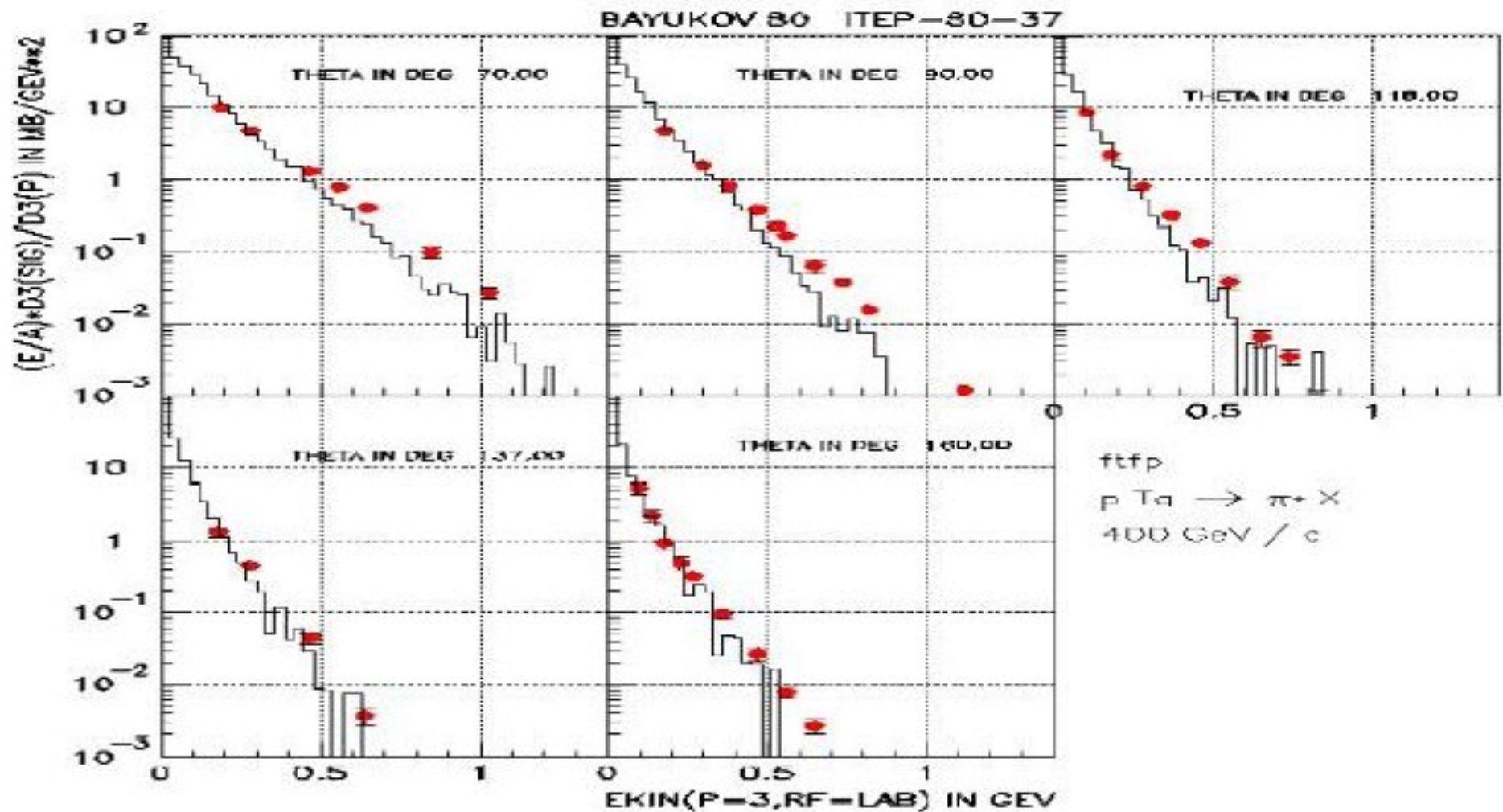

# Model-level thin-target tests

FTF validation, HARP-CDP data

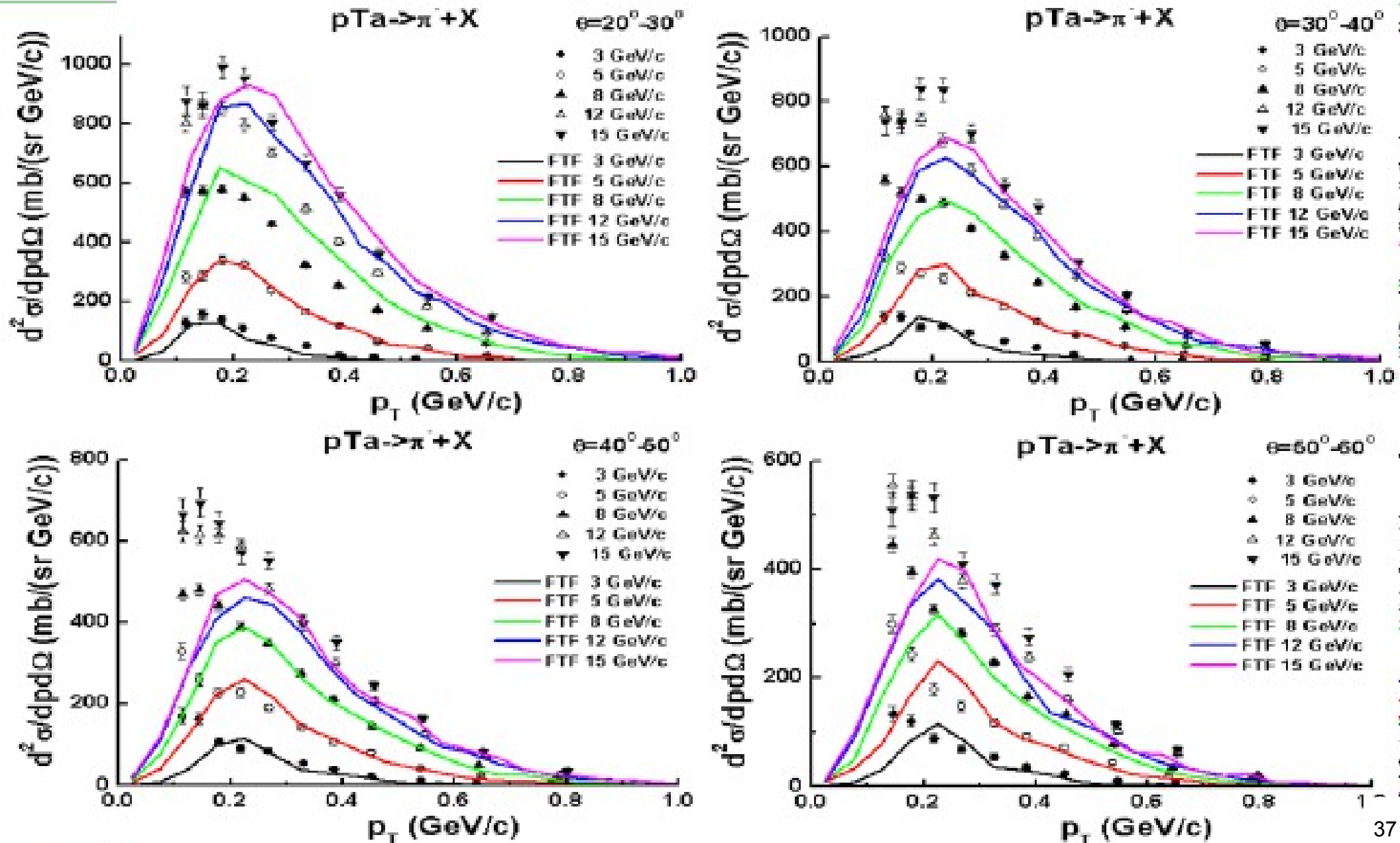

# Model-level thin-target tests

## Validation of the Bertini Cascade

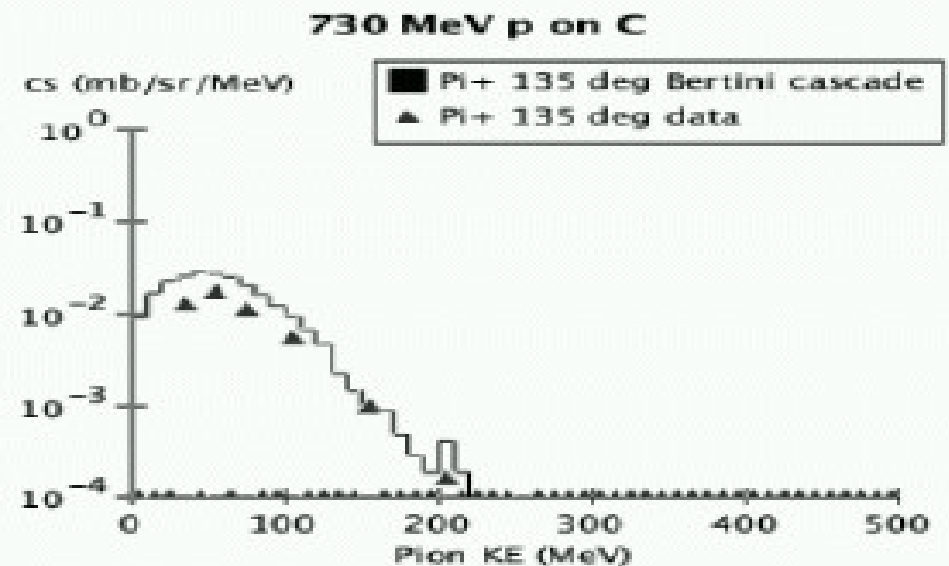
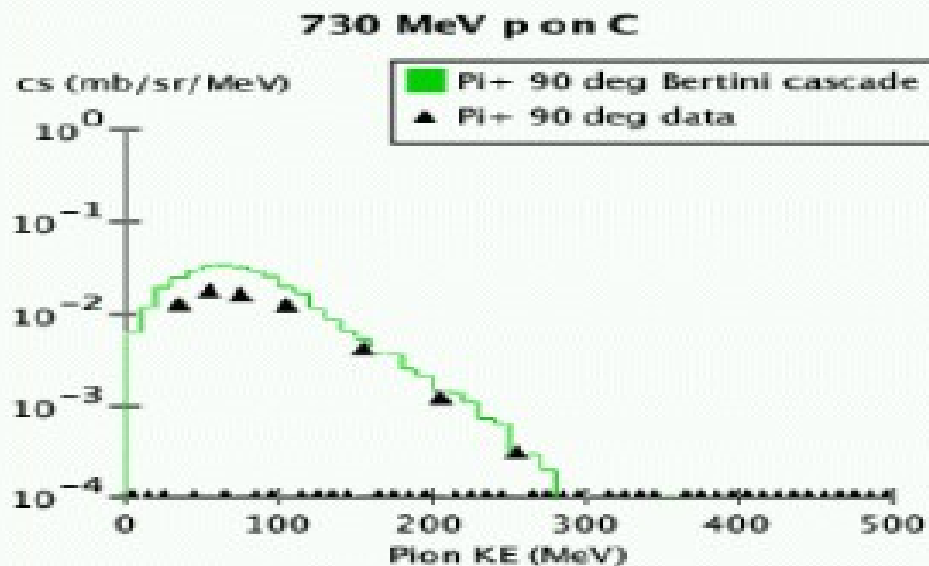
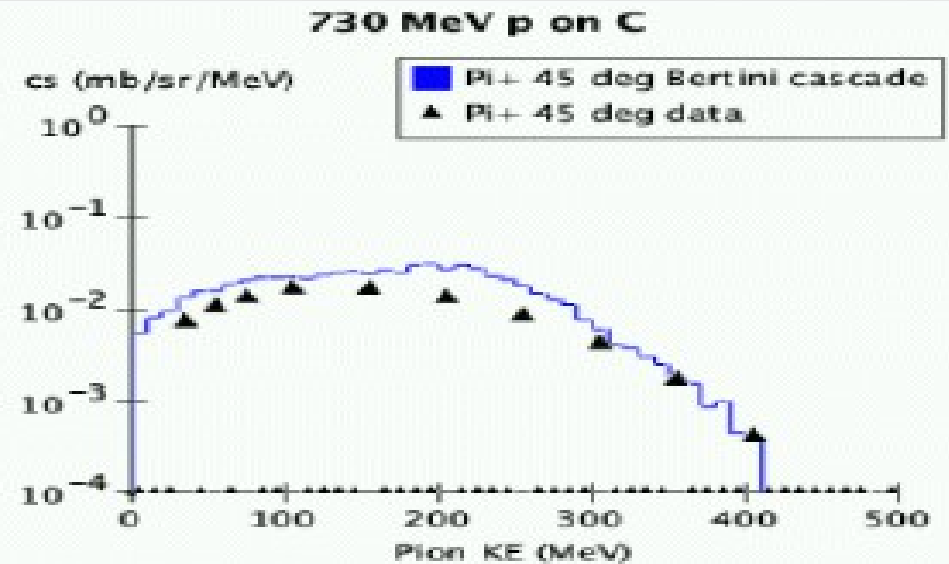
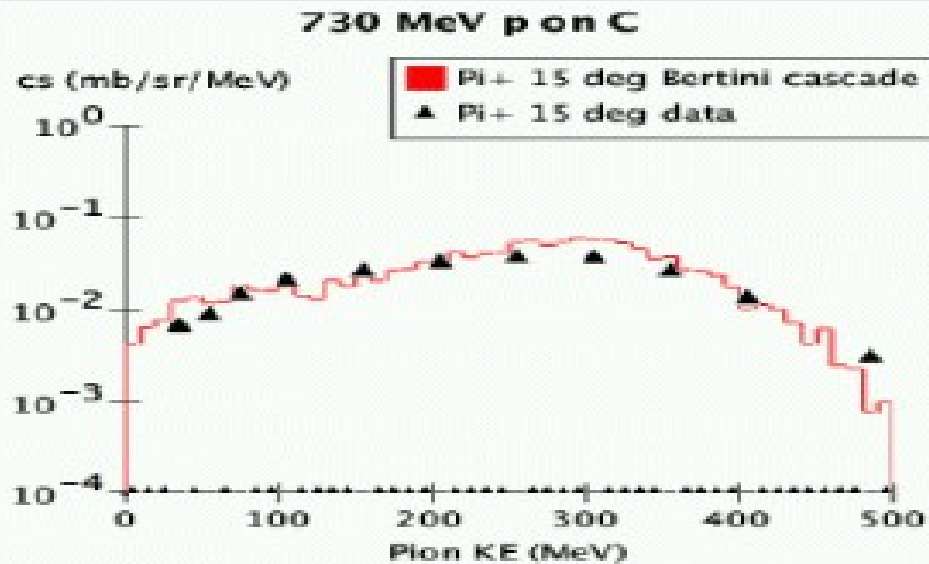



# Model-level thin-target tests

Preco validation, 22 MeV p – Fe  $\rightarrow$  n

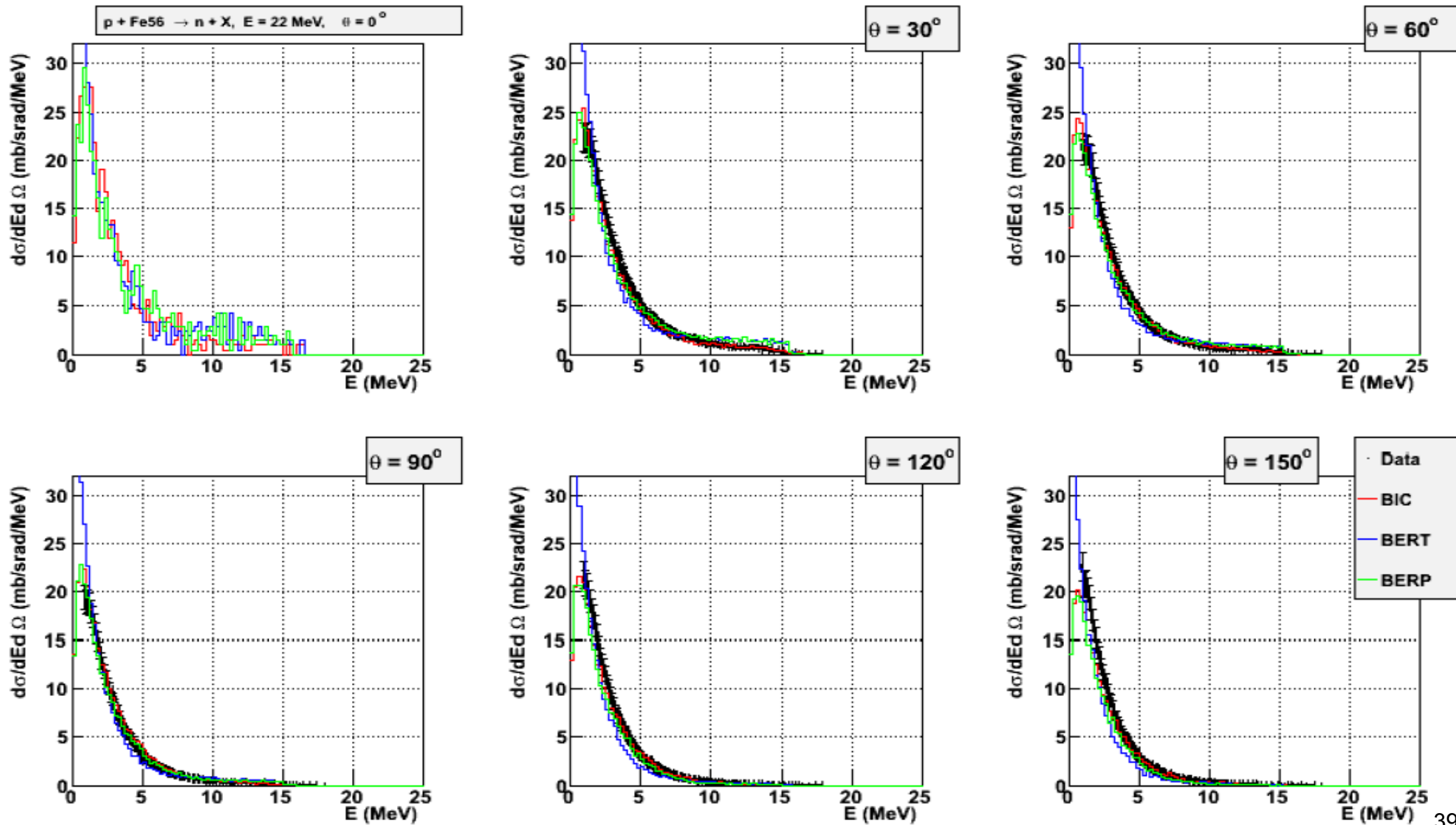

# LHC calorimeter test-beams

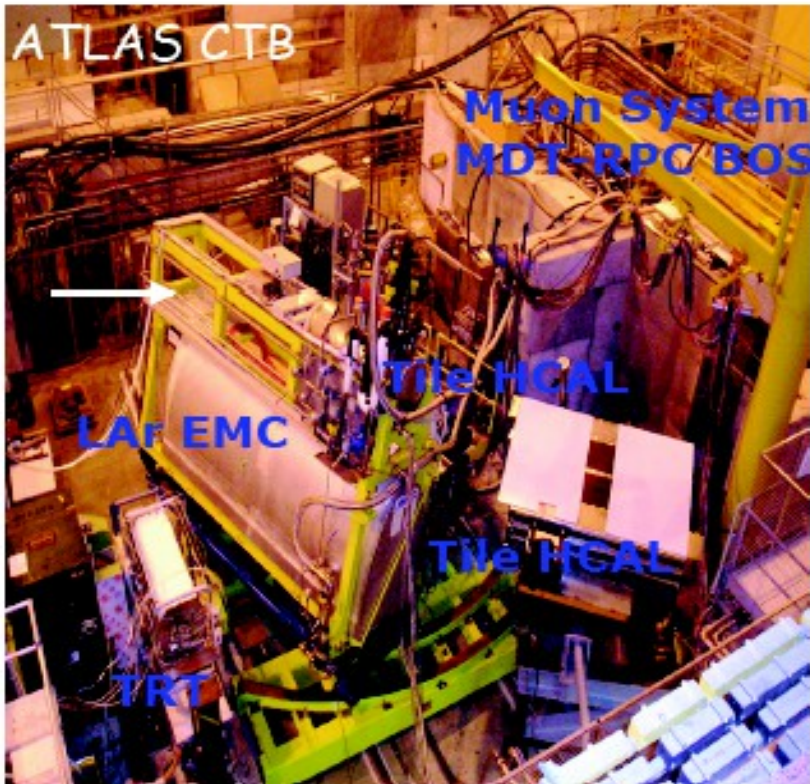
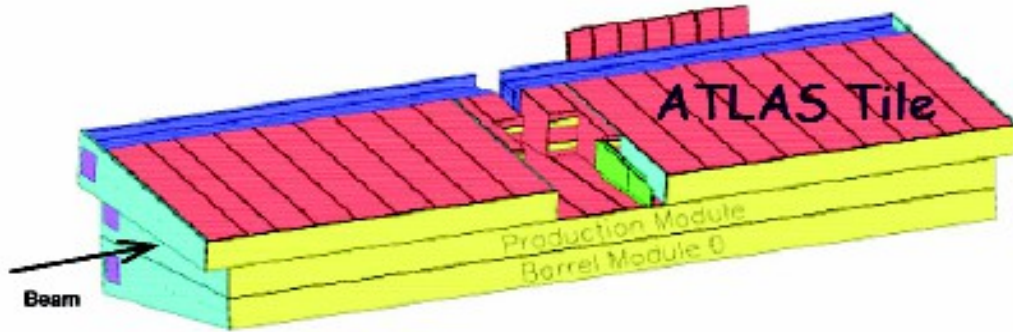

# Energy response

ATLAS TileCal test-beam

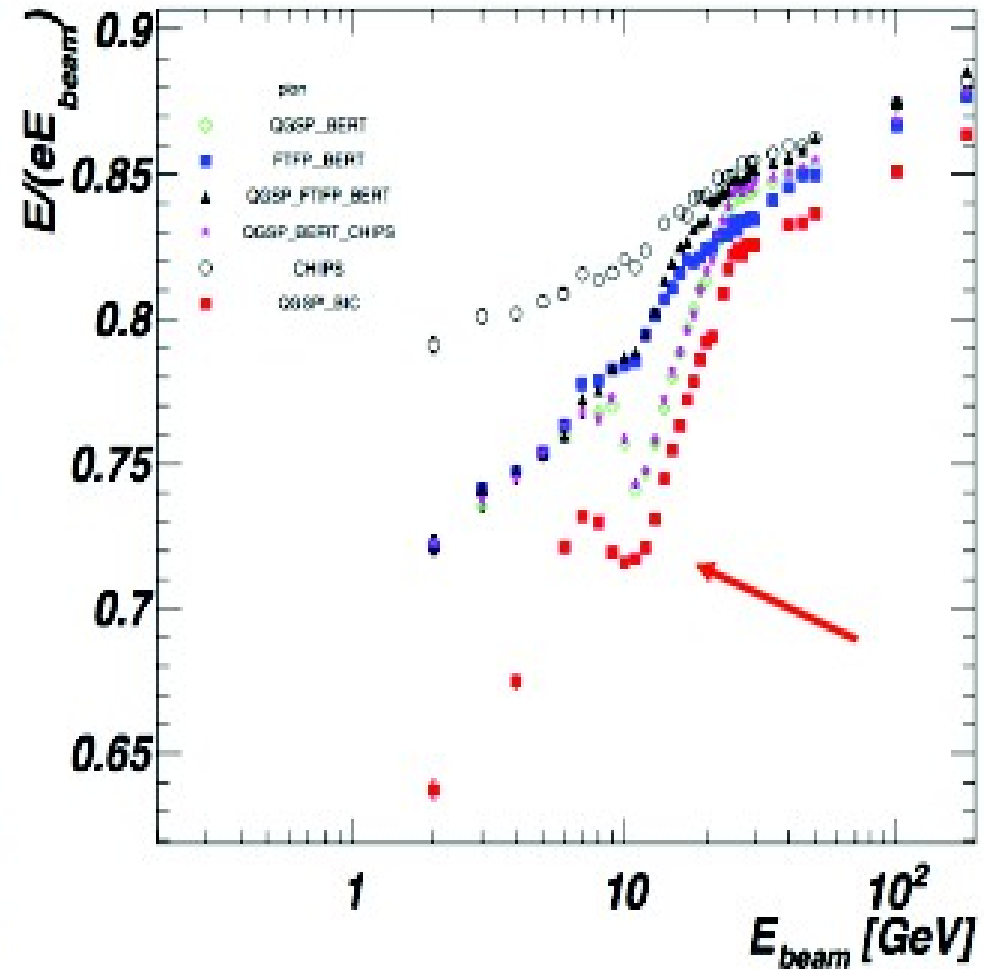
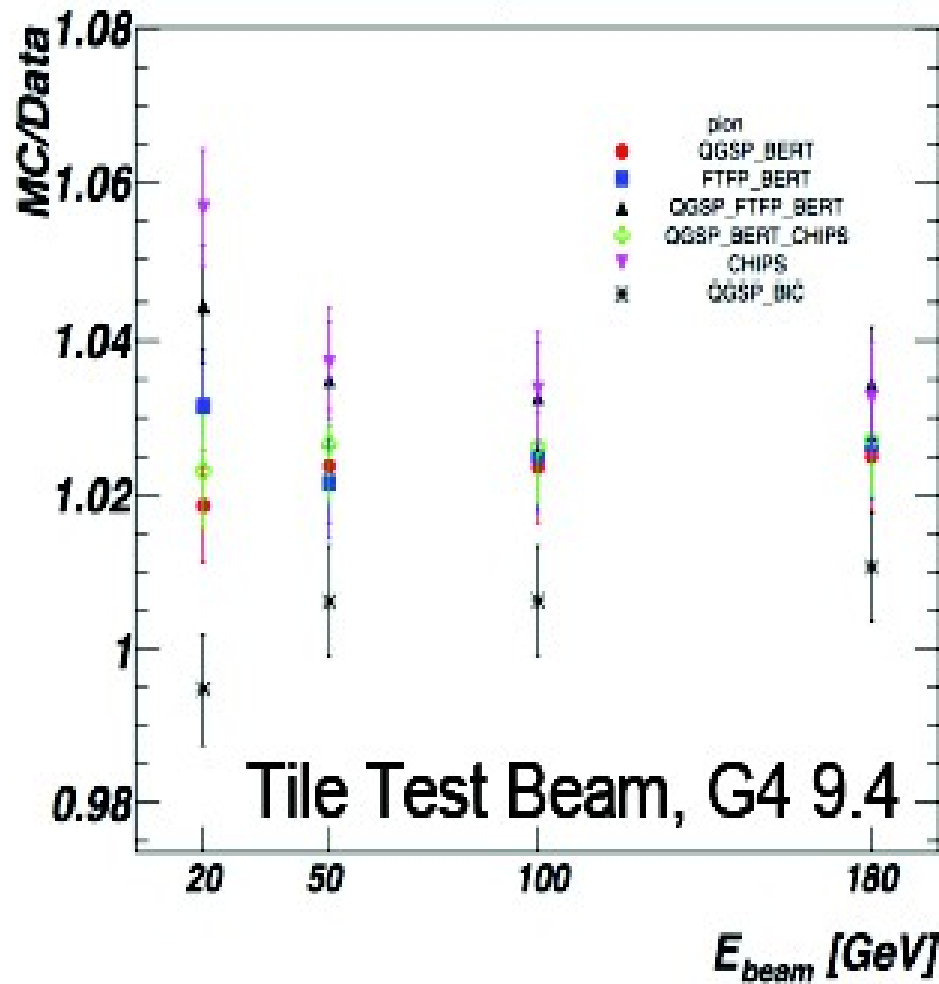

# Energy resolution

ATLAS HEC test-beam

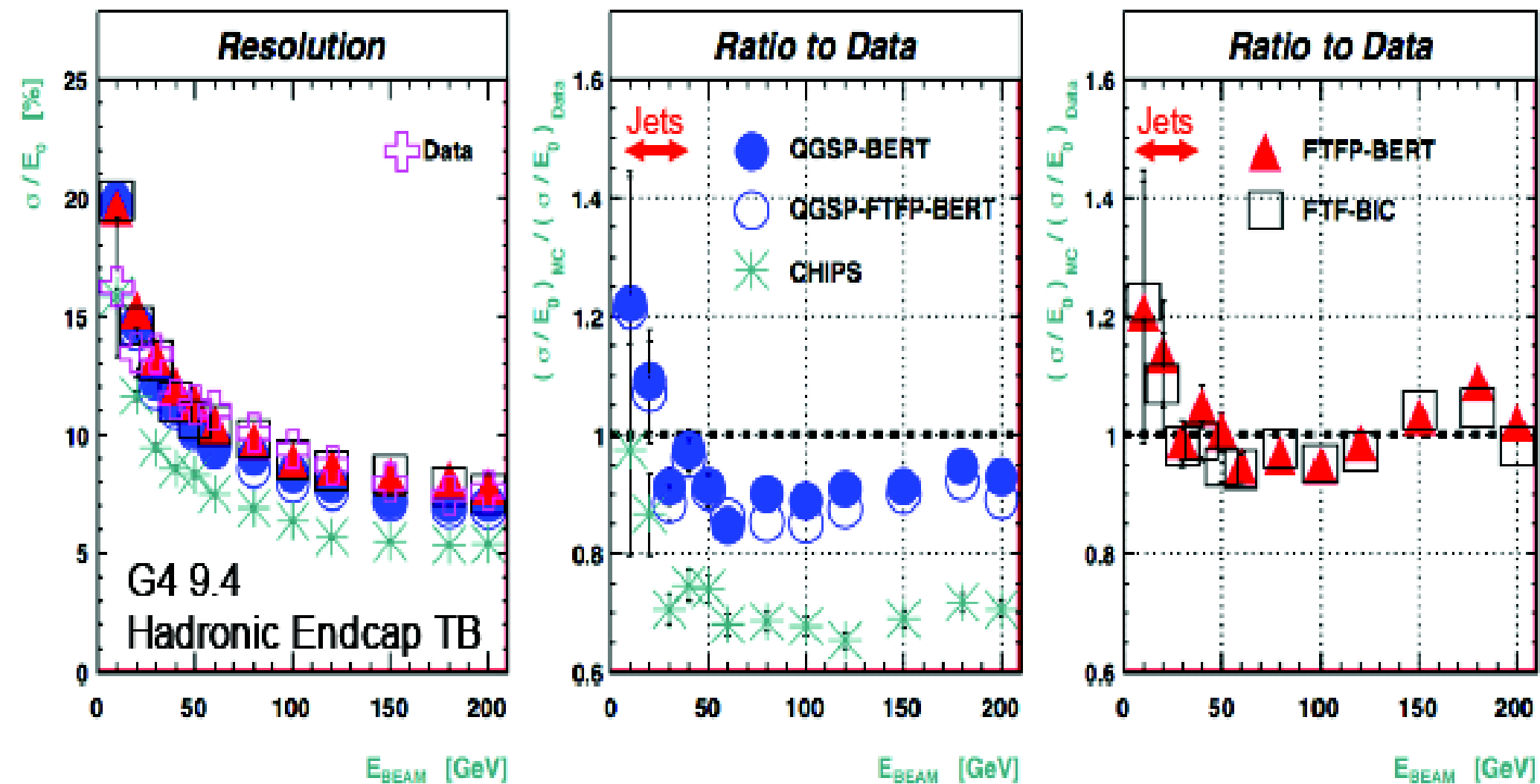

# Longitudinal shower shape

ATLAS TileCal test-beam @90°

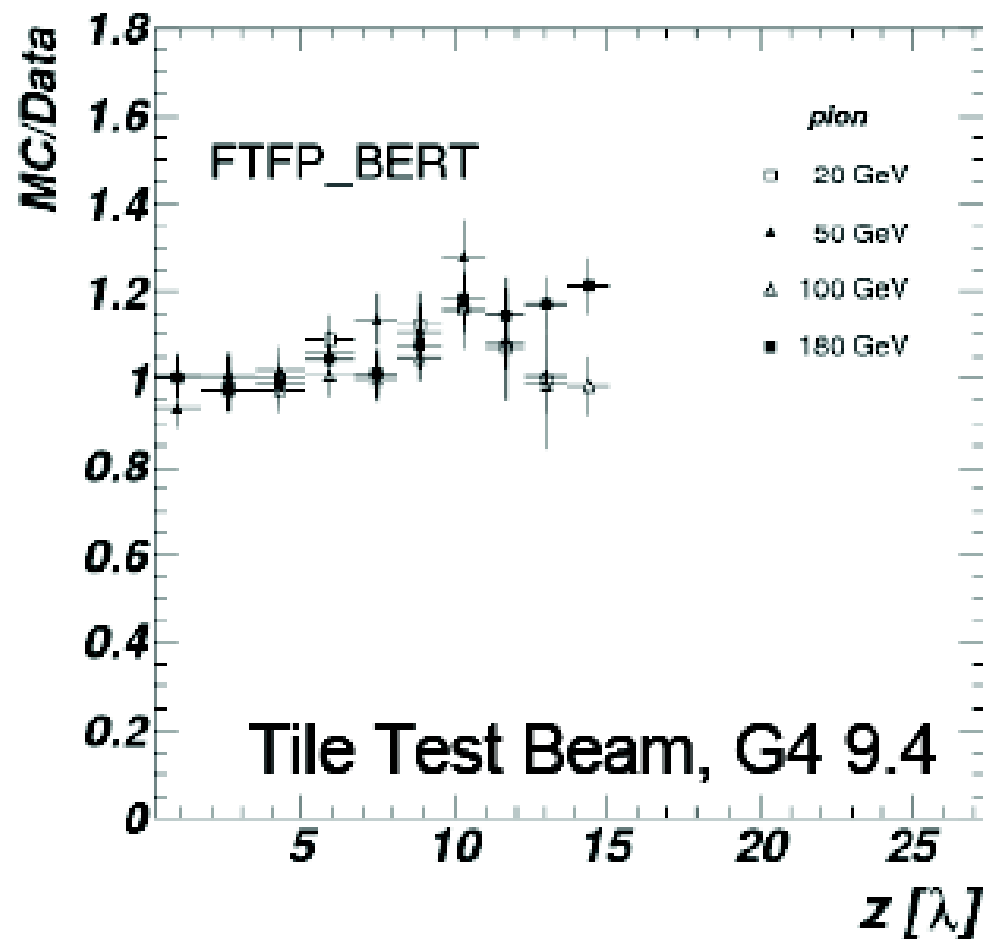
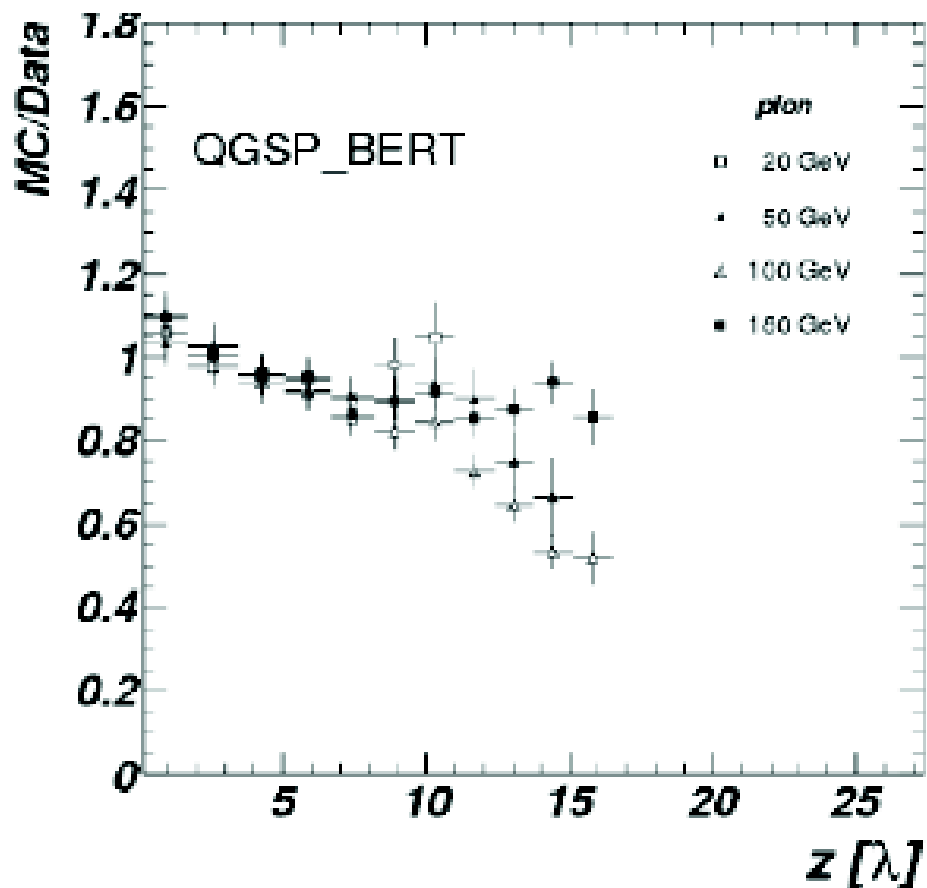
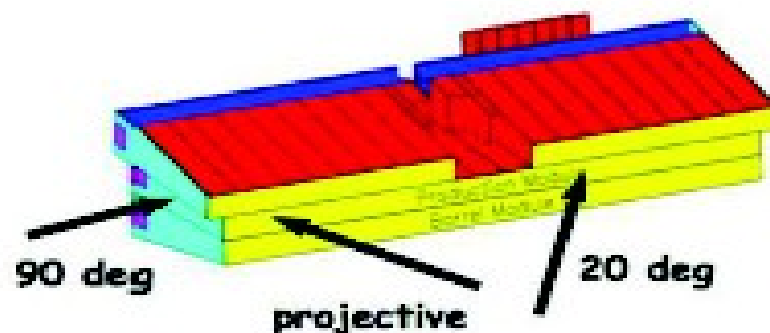

# Lateral shower shape

ATLAS TileCal test-beam @90°

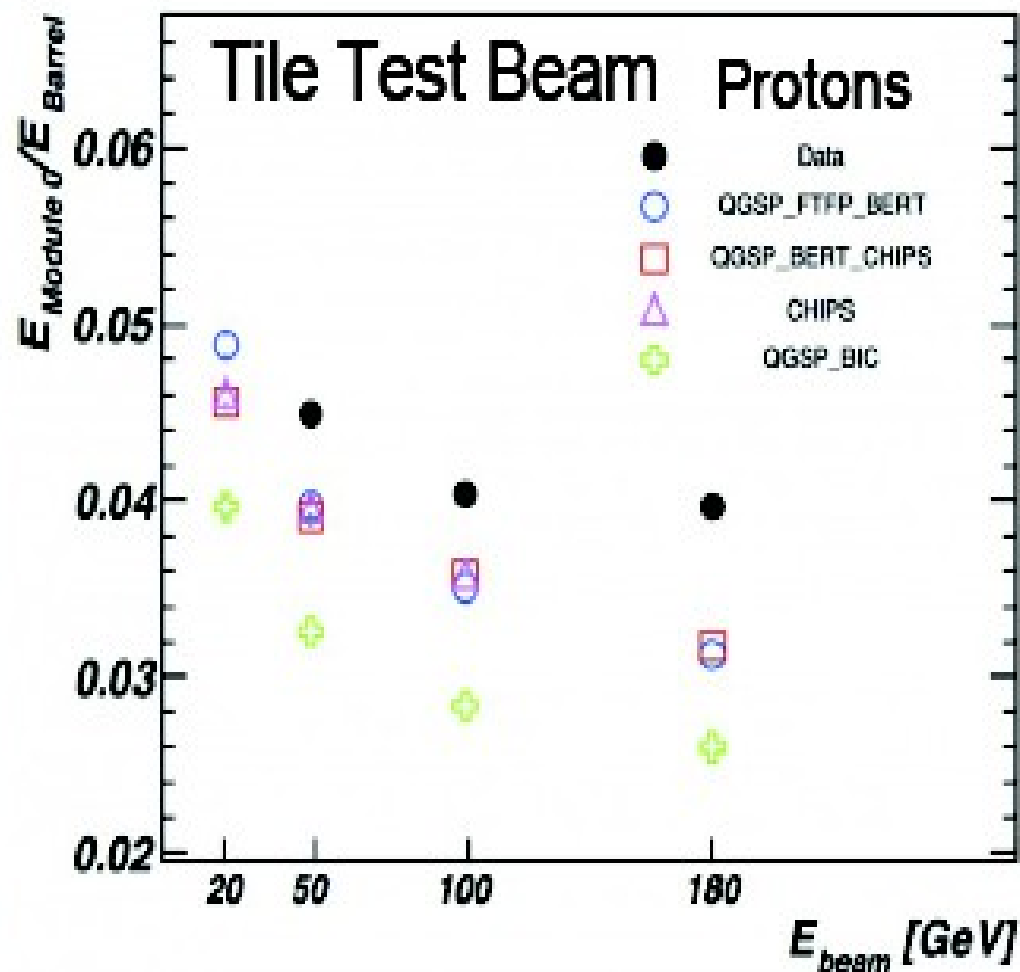
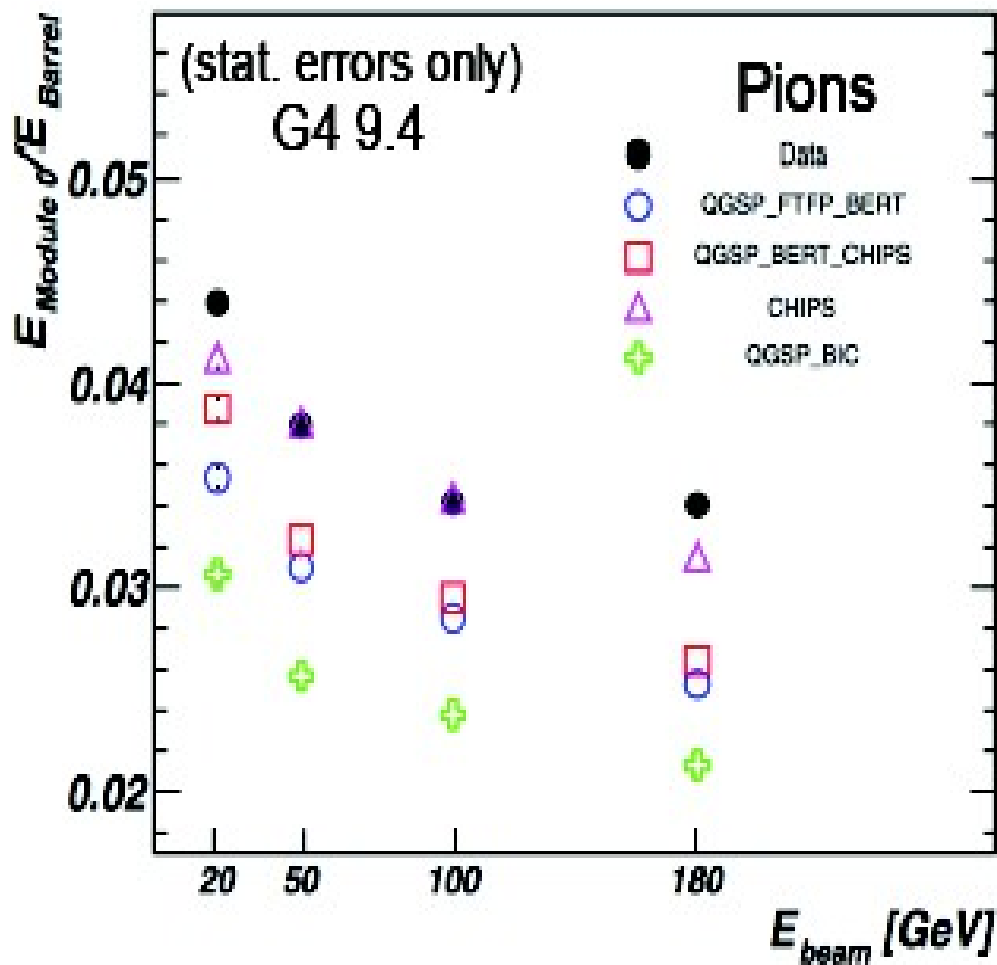
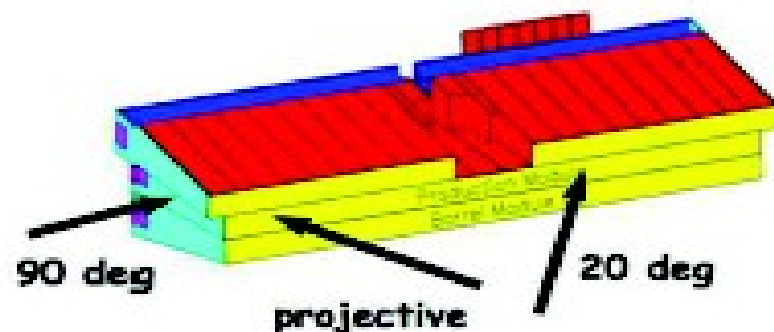

# Isolated single hadron response: simulation vs. CMS p-p data

Agreement is better than  $\pm 3\%$  between 2-20 GeV/c

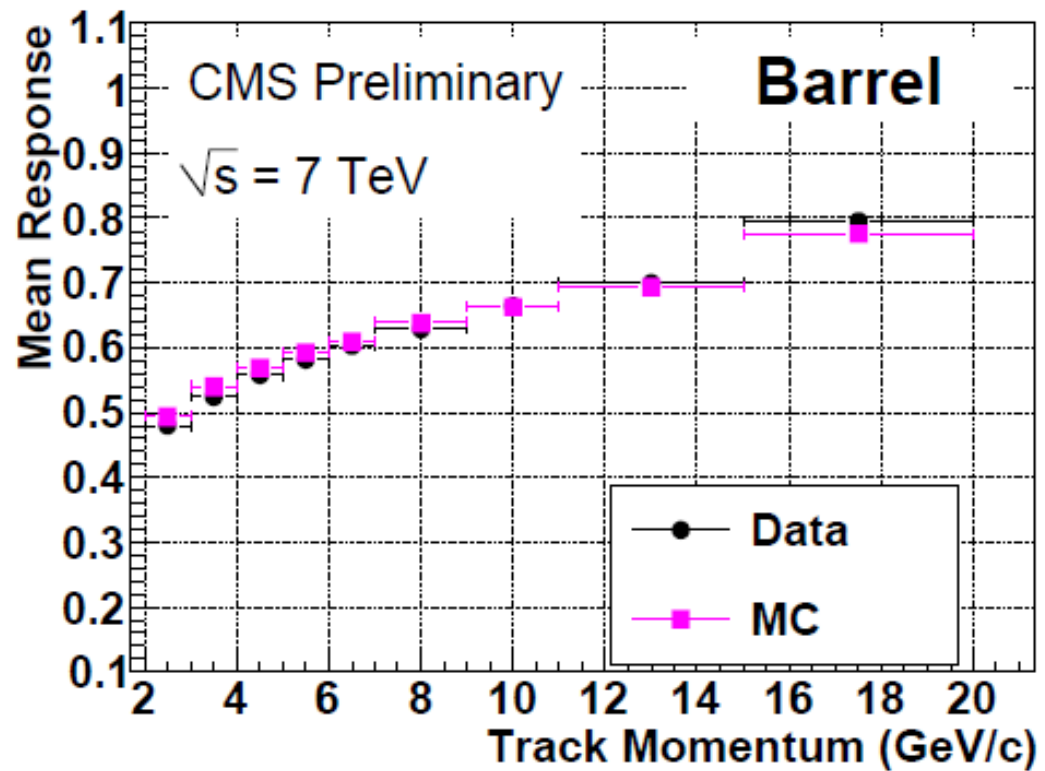
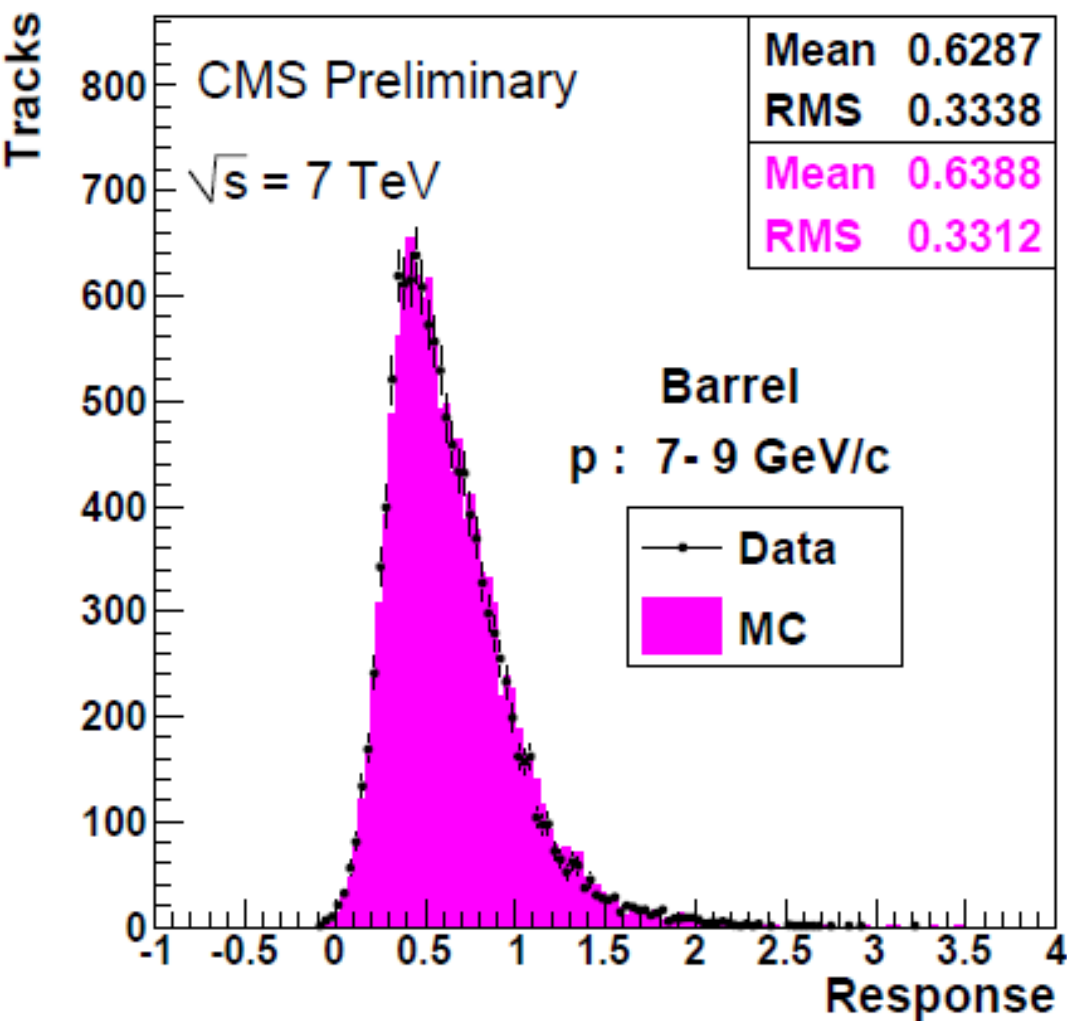

# Di-jet invariant mass: simulation vs. CMS p-p data

Very good agreement between simulation and collision data!

Three ingredients are convoluted in the simulation:

- Monte Carlo event generator: [Pythia](#)
- Detector simulation engine: [Geant4](#)
- Experiment-specific aspects: [geometry/materials](#), [digitization](#), [calibration](#), [rec.](#)

Calo jets

JPT jets

PF jets

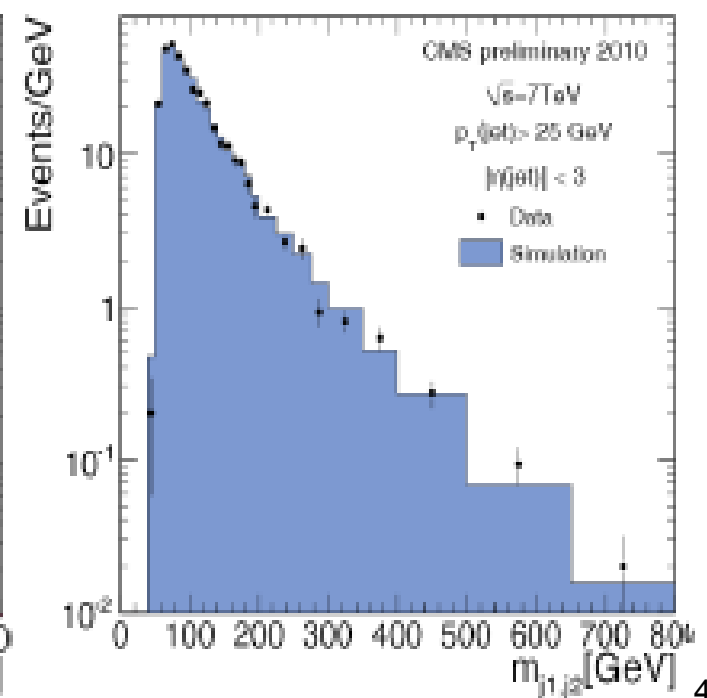
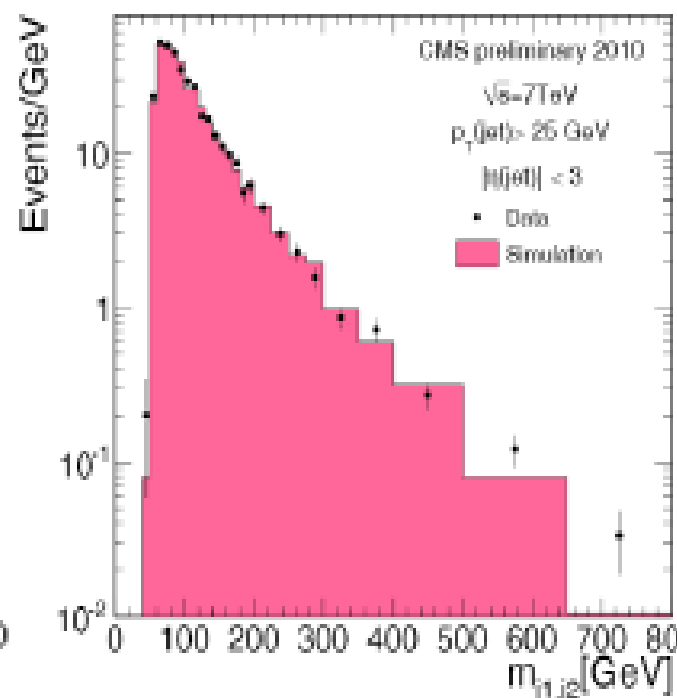
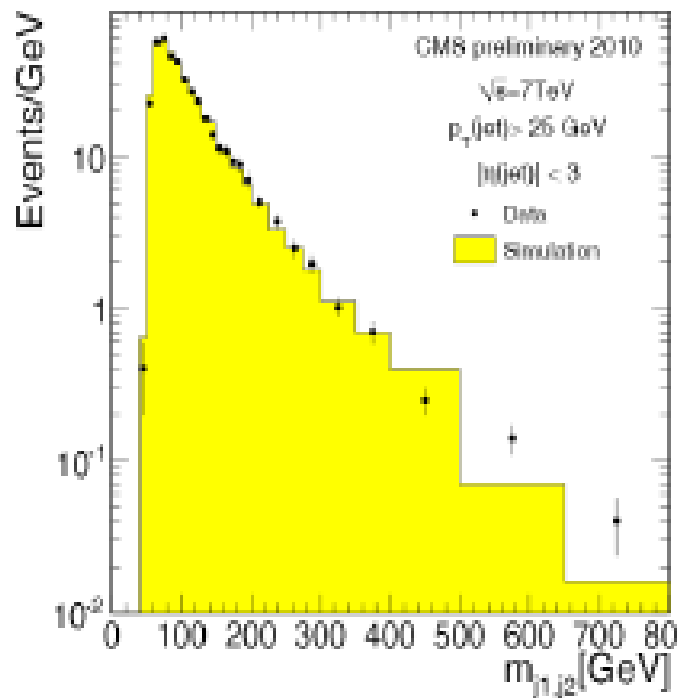



# Missing $E_T$ : simulation vs. collision data

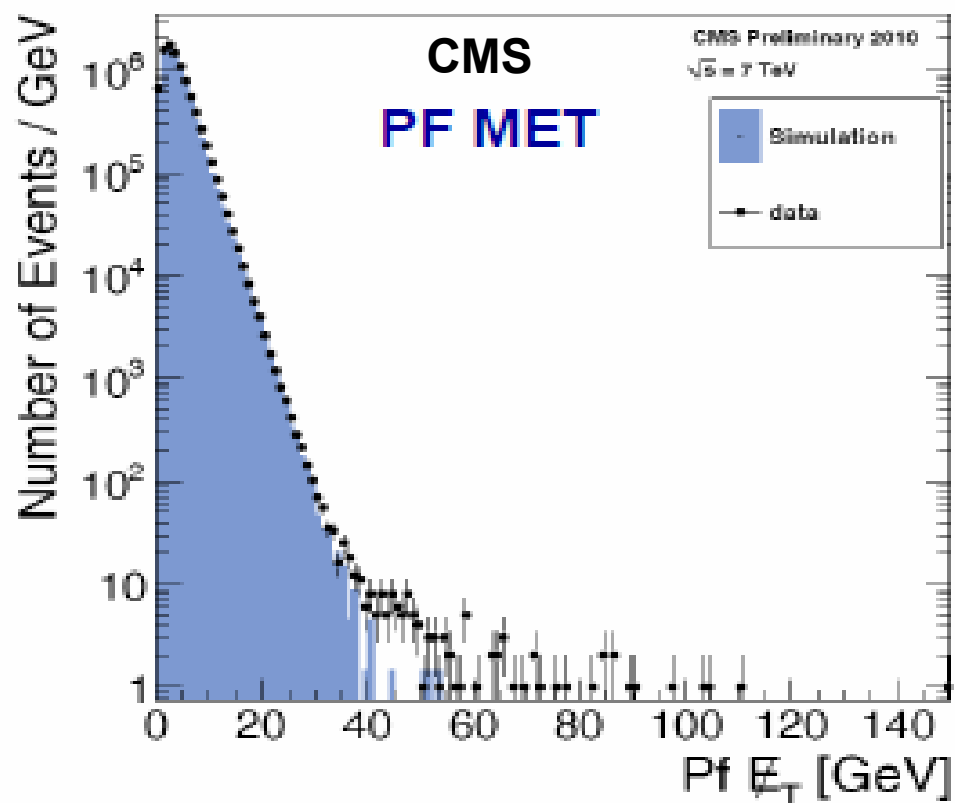
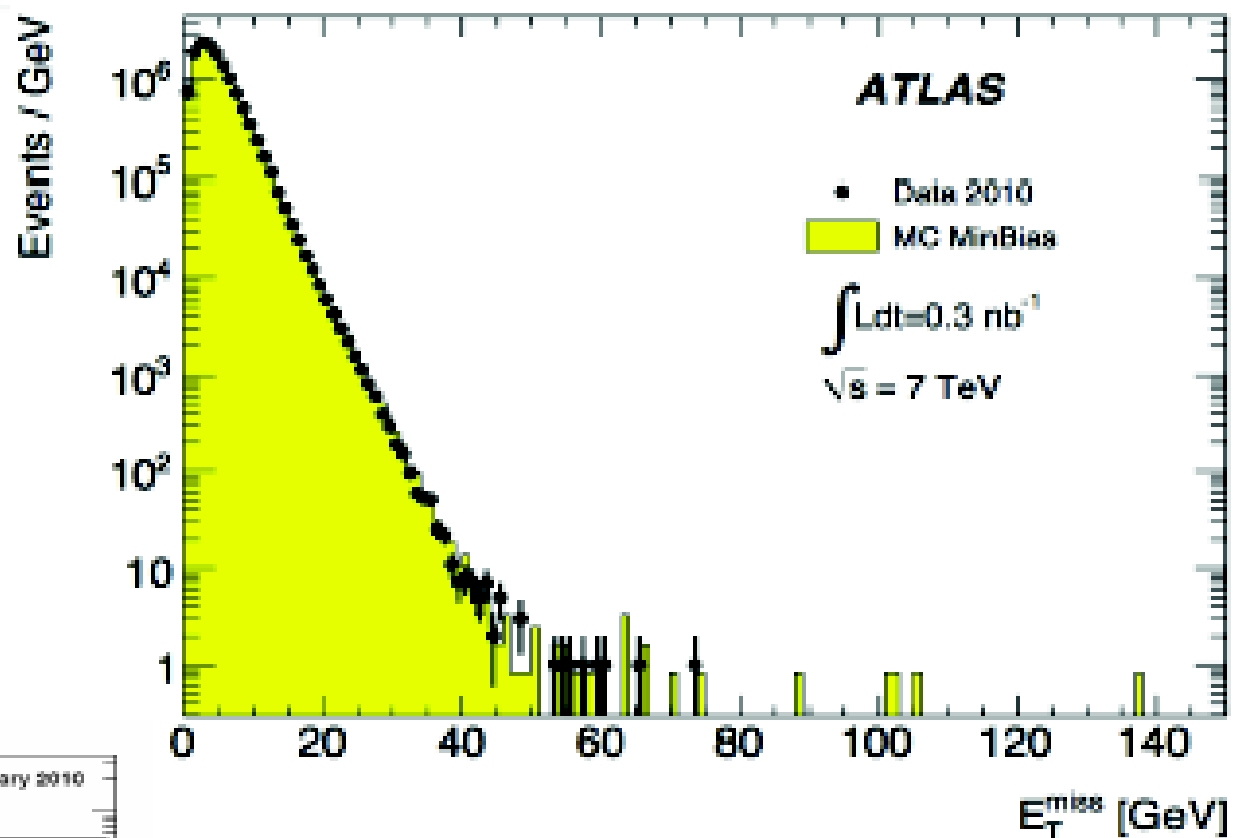

Missing  $E_T$  is a very complex  
(global) variable

Good agreement over 6  
orders of magnitudes!

# Summary

- Detector simulation is one of the main tools of modern high-energy physics
- The main challenges of detector simulation are:
  - Physics accuracy
  - CPU performance
  - Validation
- *Suggestions for you:*
  - *Learn by studying and playing with existing examples*
  - *Be critical and pragmatic when using simulations*
  - *Contribute to the validation and provide feedback*

# Other codes

- General
  - **Fluka**
  - Geant3
  - MARS
  - **MCNP / MCNPX**
- Dedicated to electromagnetic physics
  - EGS4
  - EGS5
  - EGSnrc
  - ETRAN
  - Penelope

# Acknowledgment

Thanks to:

- Katsuya Amako
- Makoto Asai
- Andrea Dotti
- Michel Maire
- Dennis Wright
- Alberto Ribon

for some of the figures used in this lecture