

Services propositions in ATLAS

PROPOSITION 1

Routing for pipes
and cables

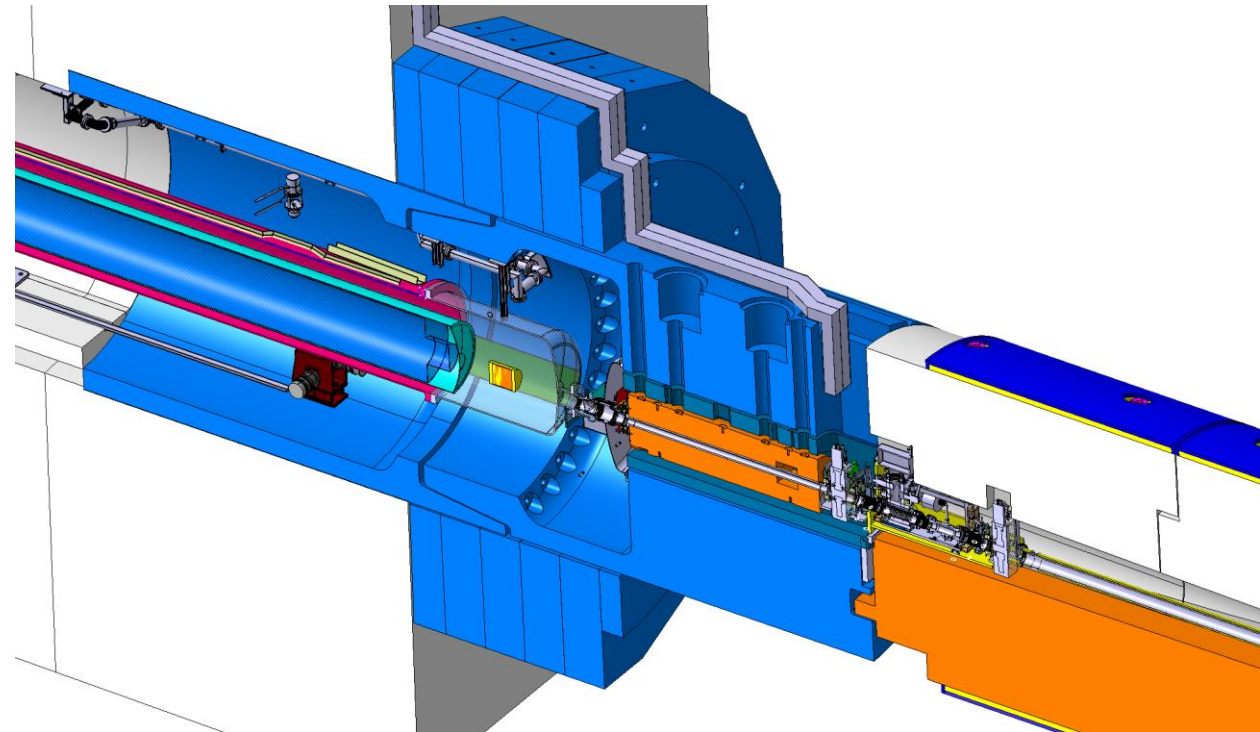
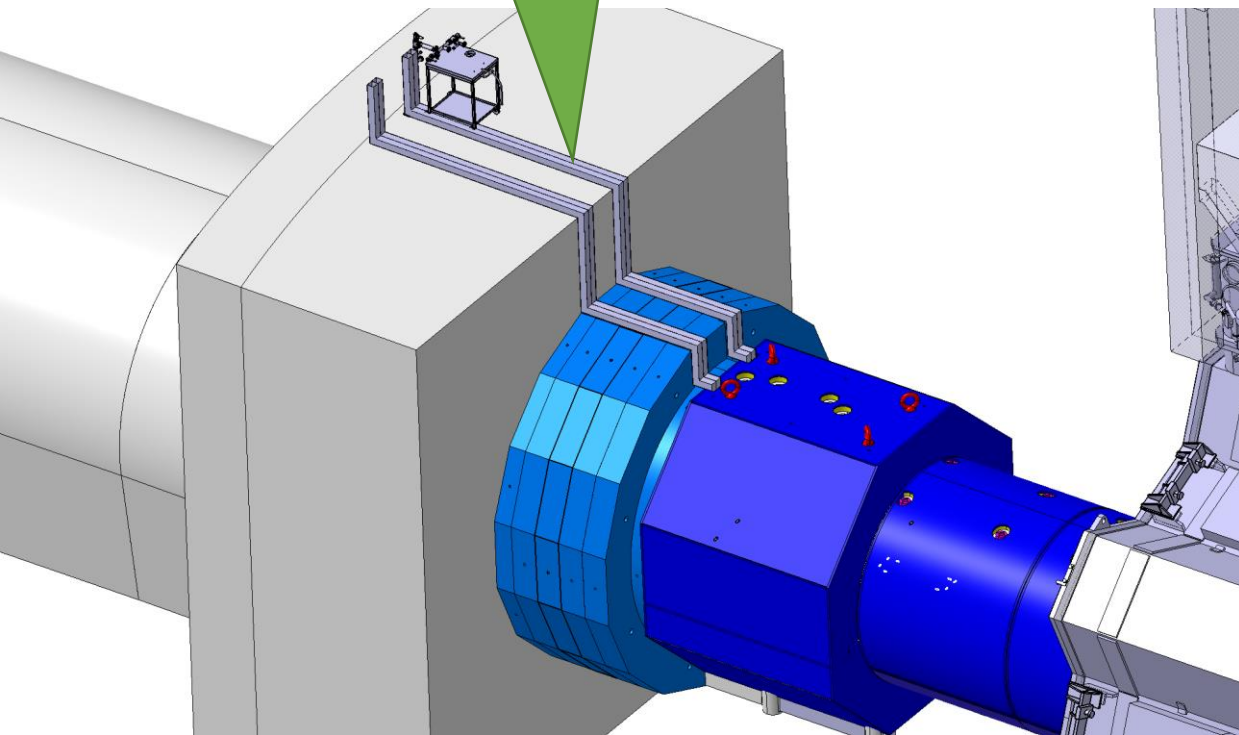

Collision with the big wheel at opening



Inconvenients :

- Collision with the big wheel →

Solution 1 : is it possible to open less the big wheel ? (100mm?)

Solution 2 : change shape of piping.

Solution 3 : machine a slot in monobloc (in-situ, 2 sections 200x100 length 550mm).

Any other solutions?

Advantages:

- Easy access, installation.

- Routing outside the Q1-TAXS region → optimal in terms of space!!!

- Easier dismantling during LS.

- **Reduced activation for people (outside shielding).**

PROPOSITION 2

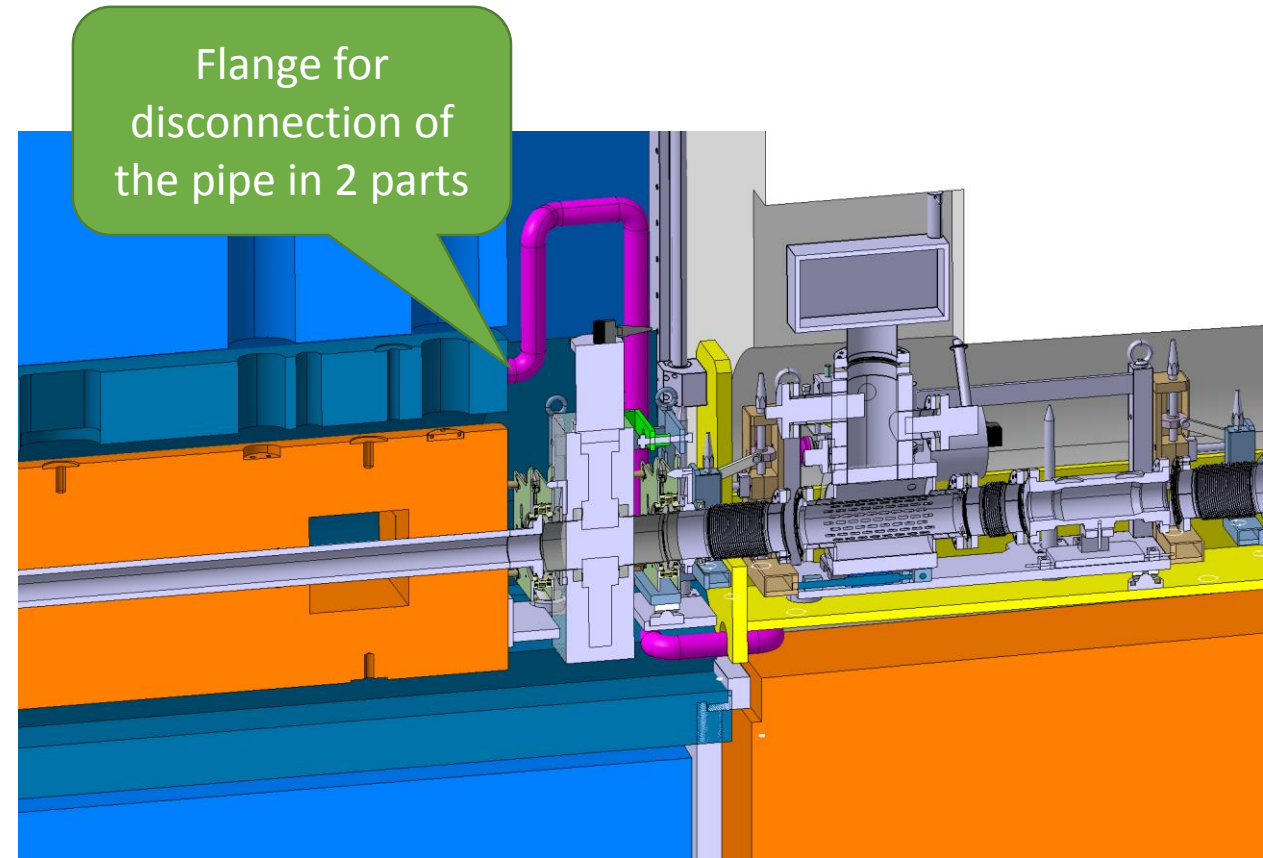
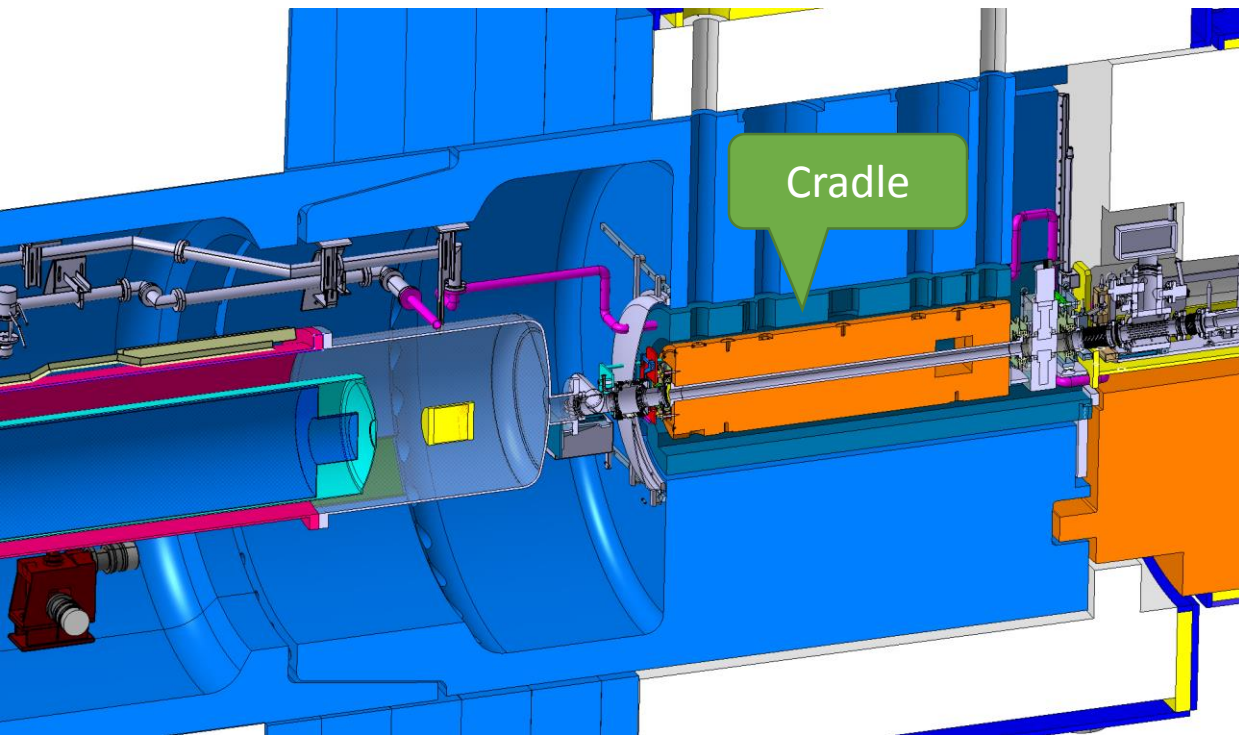

Inconvenients :

- More activation for people.
- Maintenance more difficult.
- Region Q1-TAXS busy.

Advantage:

- No problem of conflict at the moment of big wheel opening.