



中国科学技术大学

University of Science and Technology of China

21st IEEE-NPSS Real Time Conference

A programmable clock generator for automatic Quality Assurance of LOCx2

University of Science and Technology of China

Yi Feng

A programmable clock generator for automatic Quality Assurance of LOCx2



The upgrade of ATLAS Liquid Argon Calorimeter (LAr) Phase-1 trigger requires high performance data transmission. About 7000 LOCx2, the readout IC were fabricated, and an automatic Quality Assurance was needed. This work is about the control of clock-generator of the QA system.

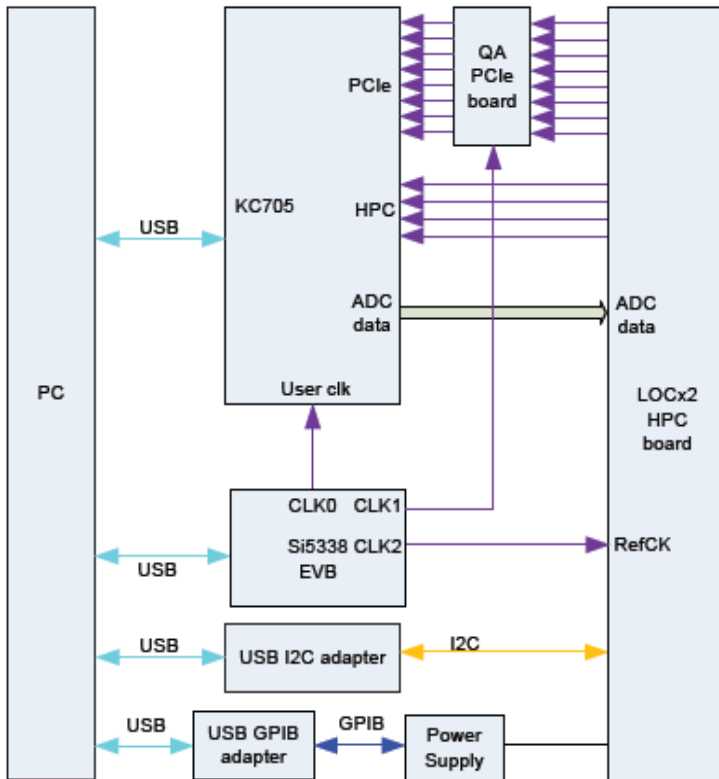

Block Diagram of QA system

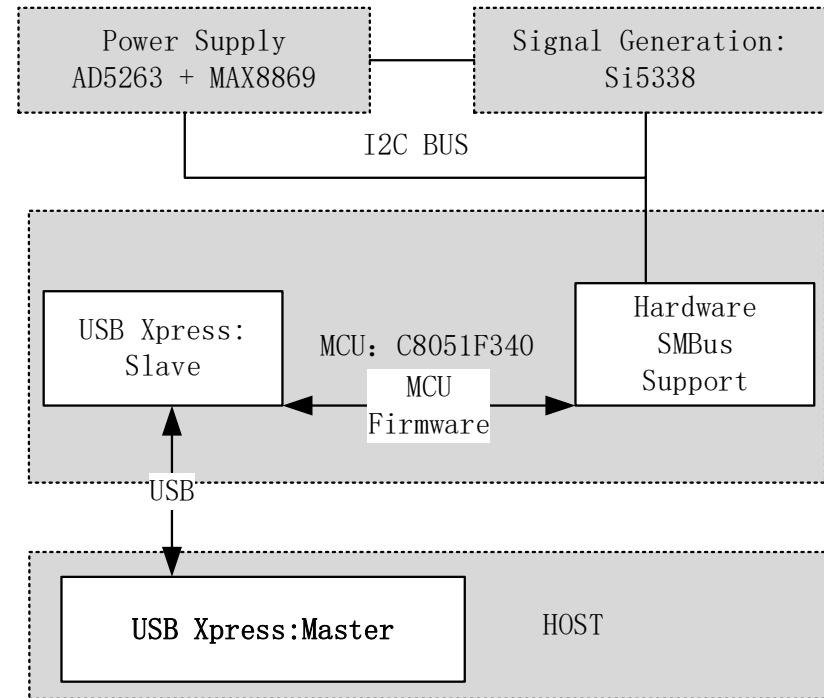

The block diagram of clock generator PCB based on Si5338 any-frequency signal generator,

A programmable clock generator for automatic Quality Assurance of LOCx2



中国科学技术大学
University of Science and Technology of China

A set of Device firmware and Host program was developed to control the Si5338

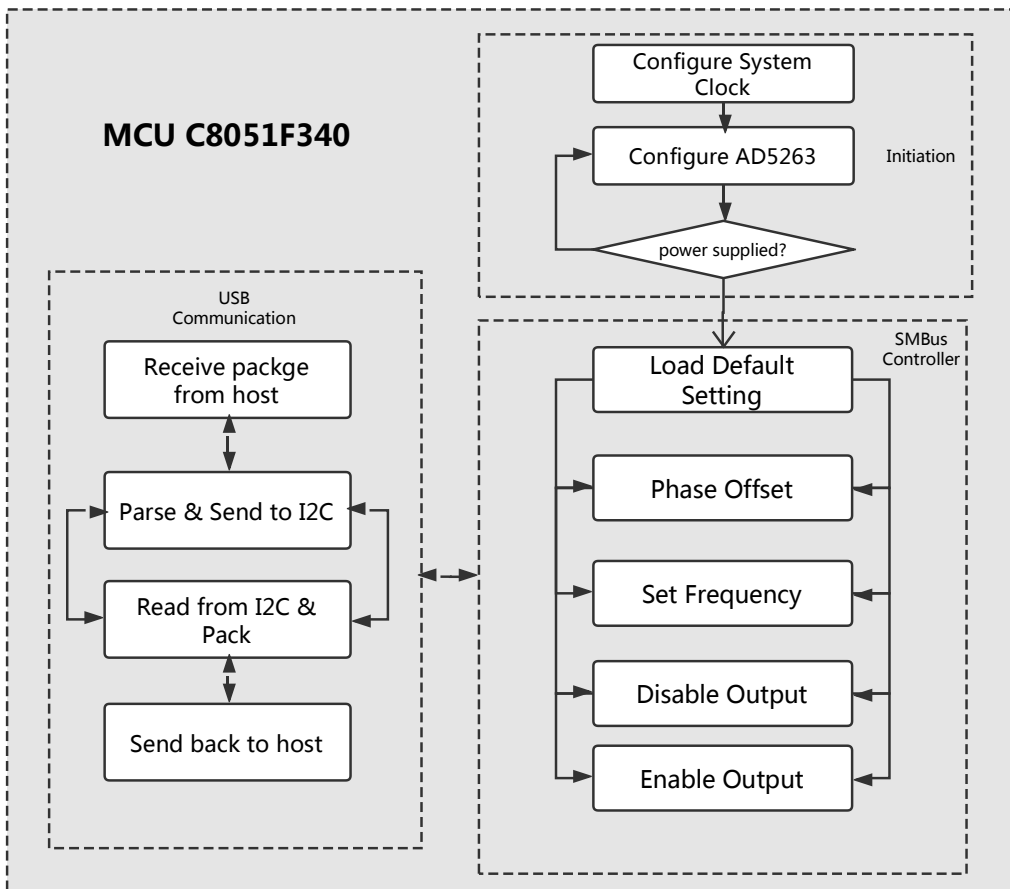

Block diagram of device firmware

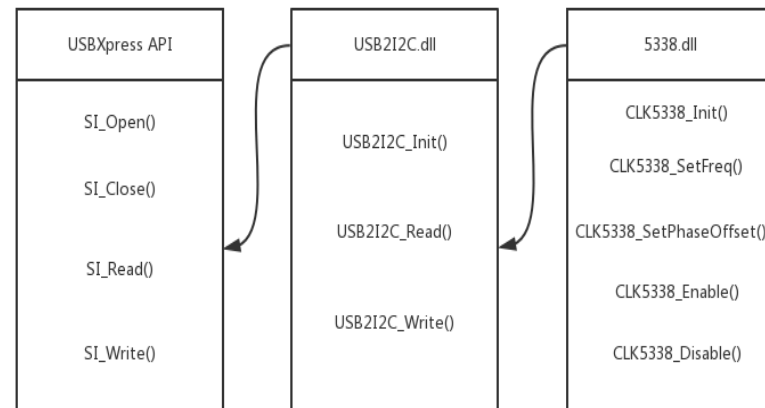

Block diagram of host program