

The Use of Java in Online Event Building and Recording at Jefferson Lab

Carl Timmer

Why Java ?

- Highly portable
- Short development time
- Easily comprehensible
- Easily maintainable
- Sufficiently fast I/O
- Event building requires little compute intensive code
- Excellent IDEs and profiling tools available at no cost

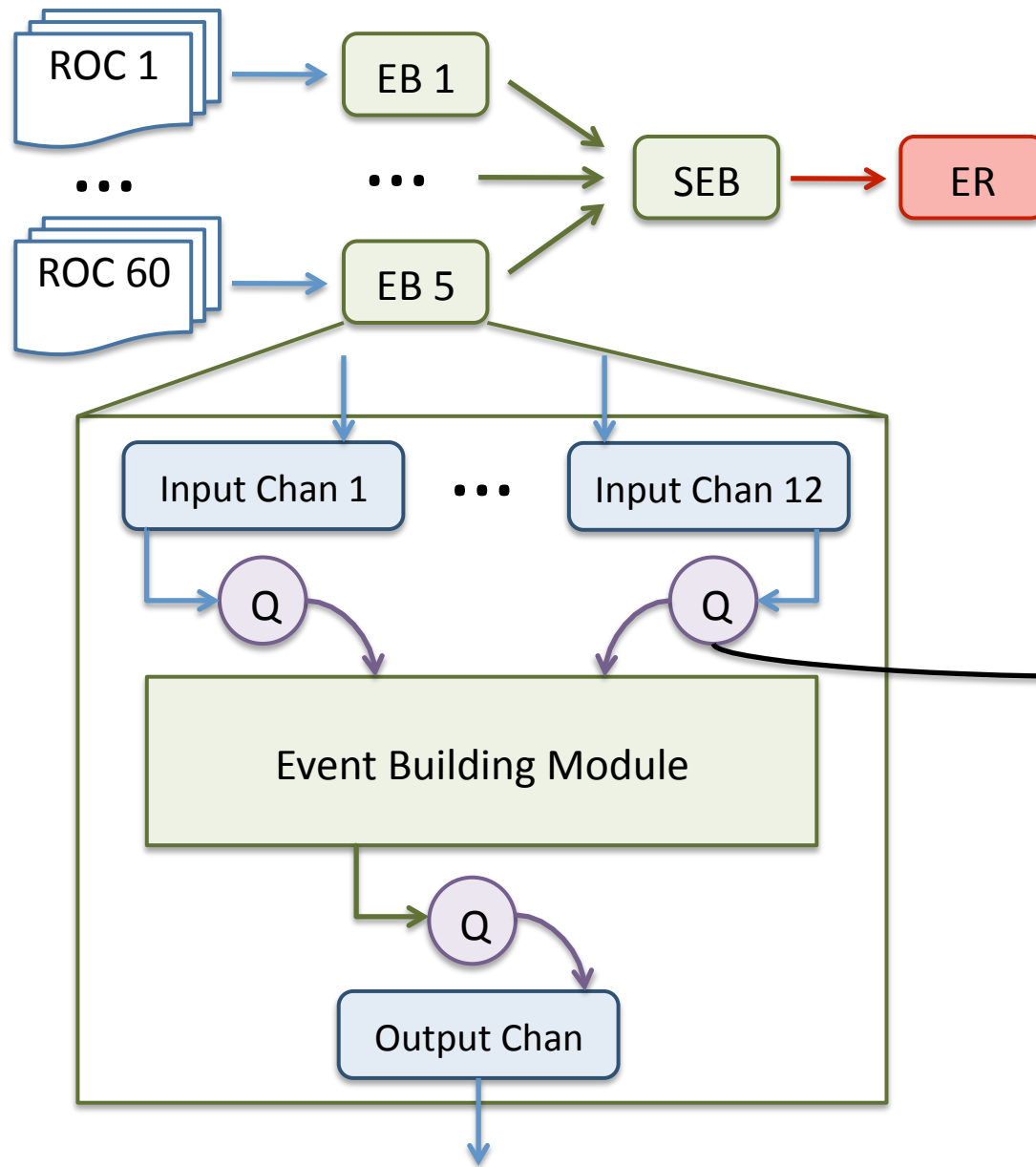

Design:
 1.5 GB/s over
 40Gb infiniband

Achieved so far:
 1.75 GB/s

Tips, Tricks, and Techniques:

- 1) Replace Java's ArrayBlockingQueues with Disruptor's ultra fast ring buffers
- 2) For others, stop by and chat