

LHCb SciFi Module Production Guide

Version 1.0

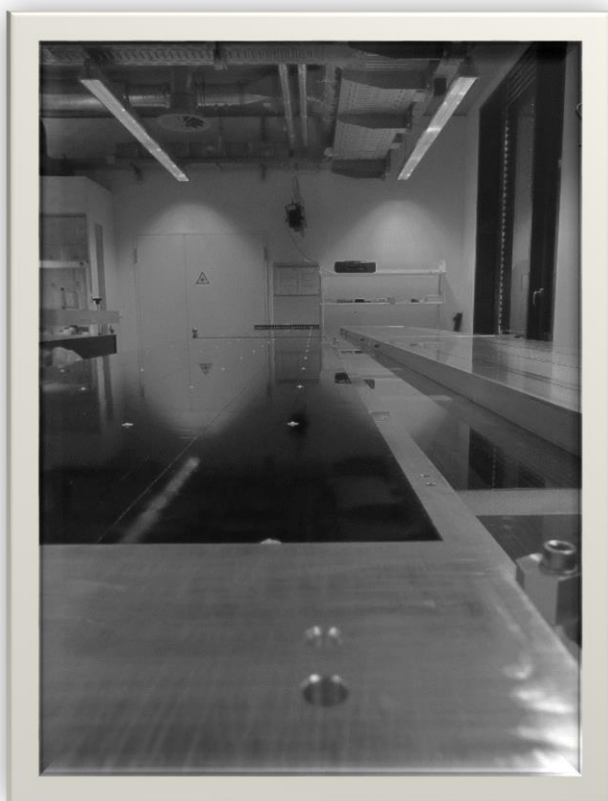

A. Anjam, S. Bachmann, T. Herold, S. Hummel, B. Leverington, T. Mittelstaedt, U. Uwer, B. Windelband

Table of Contents

| | | |
|-------|---|-------------------------------------|
| 1 | Production Parts and Supplies | 6 |
| 1.1 | Chemical Products needed: | 6 |
| 1.2 | Equipment needed by Production Step:..... | 6 |
| 1.2.1 | Light injection system | 6 |
| 1.2.2 | Longitudinal cut of SciFi mats | 6 |
| 1.2.3 | Gluing of module..... | 7 |
| 2 | Part control and preparation | Error! Bookmark not defined. |
| 2.1 | Endplugs..... | Error! Bookmark not defined. |
| 2.2 | SciFi-mats | 9 |
| 2.3 | Cold-box flange | 9 |
| 2.4 | Honey comb panel | 10 |
| 2.5 | Sidewalls (U-Profile)..... | 10 |
| 3 | Tooling and jigs | 12 |
| 3.1 | Gluing jigs..... | 12 |
| 3.1.1 | Gluing jig..... | 12 |
| 3.1.2 | Gluing and alignment jig | 13 |
| 3.2 | Lifting and turning device | 14 |
| 3.3 | Vacuum hood..... | 15 |
| 4 | Light Injection System | 16 |
| 4.1 | Light bars..... | 16 |
| 4.1.1 | Parts needed per light bar | 16 |
| 4.1.2 | Equipment needed..... | 16 |
| 4.1.3 | Production description..... | 16 |
| 4.1.4 | QA..... | 18 |
| 4.2 | Light bars in endplug..... | 18 |
| 4.2.1 | Pieces needed per endplug..... | 19 |
| 4.2.2 | Equipment needed..... | 19 |
| 4.2.3 | Production steps | 19 |
| 5 | SciFi-mat Long Cuts | 22 |
| 5.1.1 | Equipment needed..... | 22 |
| 5.1.2 | Production description..... | 22 |
| 6 | Gluing of module..... | 26 |
| 6.1 | 1 st gluing step | 26 |
| 6.1.1 | Parts | 26 |
| 6.1.2 | Equipment..... | 26 |
| 6.1.3 | Preparation | 27 |

| | | |
|-------|---------------------------------------|----|
| 6.1.4 | Production description..... | 27 |
| 6.2 | 2 nd gluing step | 36 |
| 6.2.1 | Parts | 36 |
| 6.2.2 | Equipment..... | 36 |
| 6.2.3 | Production description..... | 36 |
| 6.3 | Mounting of the cold-box flanges..... | 44 |
| 6.3.1 | Parts | 44 |
| 6.3.2 | Equipment..... | 44 |
| 6.3.3 | Production description..... | 44 |
| 6.4 | Gluing of side profiles | 45 |
| 6.4.1 | Parts | 45 |
| 6.4.2 | Production description..... | 46 |
| 7 | Appendix | 48 |
| 7.1 | Data sheets..... | 48 |
| 7.2 | Safety sheets | 48 |
| 7.3 | Drawings | 48 |

Table of figures

| | |
|--|-------------------------------------|
| Figure 1 example of a manufacturing drawing of the EndPlug light injection..... | Error! Bookmark not defined. |
| Figure 2 both endplugs types (old version)..... | Error! Bookmark not defined. |
| Figure 3 SciFi mat with mat pins up | 9 |
| Figure 4 Coldbox flange..... | 10 |
| Figure 5 Honey comb panel | 10 |
| Figure 6 Sidewalls..... | 11 |
| Figure 7 Overview gluing jig | 13 |
| Figure 8 Overview gluing and alignment jig (with half module on it)..... | 14 |
| Figure 9 Overview lifting and turning device | 14 |
| Figure 10 Detail lifting and turning device..... | 15 |
| Figure 11 Overview vacuum hood | 15 |
| Figure 12 Light bar with fibre | 16 |
| Figure 13 One of the gluing jig for the light bars open and closed/equipped | 17 |
| Figure 14 Cured light bar with fibre | 17 |
| Figure 15 Scratching area; scratched light bar..... | 17 |
| Figure 16 Box with ready to use mirrors and punching device; glued mirror on end of fibre | 18 |
| Figure 17 Light injection features of the endplug "Light injection" (top figure mat side facing up, bottom figure outside) | 18 |
| Figure 18 Sets of light bars thread into endplug..... | 19 |
| Figure 19 Glue in groove for light bar | 19 |
| Figure 20 Crossing of cables and light bars..... | 20 |
| Figure 21 Strain relief of the cables of the light bars..... | 20 |
| Figure 22 Teflon space holder into the routing groove | 20 |
| Figure 23 Fastening clamps on Al-bar (the Teflon spacers are not shown on this picture) | 21 |
| Figure 24 Placing uncut mat into cutting jig | 22 |
| Figure 25 Dowel pins for positioning the endpieces with respect to the jig | 23 |
| Figure 26 Insuring pins of mat going into the alignment groove in the jig..... | 23 |
| Figure 27 Upper plate screwed to the lower plate | 24 |
| Figure 28 Tape on cut sides of the mats | 24 |
| Figure 29 Cutting one side of the mat | 25 |
| Figure 30 Overview module | 26 |
| Figure 31 Mixing Araldit 116 | 27 |
| Figure 32 Glue on silicon paper | 28 |
| Figure 33 Applying glue with the roller to the endplug | 28 |
| Figure 34 Applying glue on the inner edge of the endpiece face | 29 |
| Figure 35 Endplug in gluing jig | 29 |
| Figure 36 Dowel pins for endpieces mirror side | 30 |
| Figure 37 Placing mats to the gluing jig | 30 |
| Figure 38 Control fitting of the mats before glue application | 31 |
| Figure 39 Applying glue with the roller to the endplug | 31 |
| Figure 40 Applying glue with a syringe to the endpieces | 31 |
| Figure 41 Endplug on mats | 32 |
| Figure 42 Bridge "HE_LHCb_ScIFI_VOR_GJ_008201_D_0__ABSTECKVORRICHTING-EPIECE-EPlug" | 32 |
| Figure 43 Insure proper fitting of the dowel pins into the endplugs and endpieces | 33 |
| Figure 44 Applying the glue with the glue applicator in sinuous lines | 33 |
| Figure 45 Spreading of the glue with the toothed spatula | 34 |
| Figure 46 Glue on endplug "HE_LHCb_ScIFI_PAN_908200_A_0__EndPlugLI-LI-BAR" | 34 |
| Figure 47 Alignment of the Panel wrt. the endpieces mirror side..... | 35 |

| | |
|--|----|
| Figure 48 Silicon paper and aluminum sheet at endplug | 35 |
| Figure 49 “Lifting and Turning device” aligned and fixed to the endplug | 37 |
| Figure 50 Lifting carefully the half module | 38 |
| Figure 51 Endplug lifted from gluing jig | 38 |
| Figure 52 Mats lifted from gluing jig | 39 |
| Figure 53 “Security belt” | 39 |
| Figure 54 “Security belt” attached to the “Lifting and Turning device” | 40 |
| Figure 55 Gluing table with extractable bars | 40 |
| Figure 56 Remove of the half module from jig | 41 |
| Figure 57 “Lifting and Turning device” with half module turned and placed next to the gluing table | 41 |
| Figure 58 Half module been pushed on the gluing jig | 42 |
| Figure 59 Bridge placed on endplug and on endpieces mirror side and aligned with dowel pins | 43 |
| Figure 60 Eccentric device blocking the position of the module | 43 |
| Figure 61 Sinuous lines of glue spread over all mats with the toothed spatula..... | 44 |
| Figure 62 Inner edge of the sealing surface coldbox and gap between neighboring endplugs | 45 |
| Figure 63 Applying glue between side walls and polyimide surface of panels..... | 46 |
| Figure 64 PET-tape to avoid the glue spreading out..... | 47 |

1 PRODUCTION PARTS AND SUPPLIES

1.1 CHEMICAL PRODUCTS NEEDED:

Cleaning agent

- Isopropanol

Non-stick agent

- Sealer agent Mikon 199 (Supplied by Münch Chemie, D-69469 Weinheim)
- Release agent Mikon 205 (Supplied by Münch Chemie, D-69469 Weinheim)

Epoxies

- Araldit AW116 (Supplied by Bodo Möller Chemie, D-63069 Offenbach)
- Araldit HV953UBD (Supplied by Bodo Möller Chemie, D-63069 Offenbach)
- EPO-TEK 301-2FL (Supplied by Kummer GmbH, D-86167 Augsburg)
- EPO-TEK 302-3M (Supplied by Kummer GmbH, D-86167 Augsburg)

1.2 EQUIPMENT NEEDED BY PRODUCTION STEP:

Parts with names beginning with "HE_LHCb_SCIFI_PAN..." have their pdf drawings included in the attached zip file. They can also be found on CERN EDMS under LHCb->SciFi->Modules.

1.2.1 Light injection system

1.2.1.1 Parts

- Light bars "HE_LHCb_SCIFI_PAN_008100_P_0_LI-BAR"
- Single Core PMMA Fibre (28000001 HITRONIC® POF SIMPLEX PE)
- Mirror (Aluminised Mylar) foil
- VCSEL Pocket covers
- Endplugs "HE_LHCb_SCIFI_PAN_008030_P_2_EndPlug_light-injection"

1.2.1.2 Supplies and other Equipment

- Glue EPOTEK 302-3M and Araldit AW116 / Jigs / syringe
- Cutting tool for fibres
- Scratching device (Vernier height gauge)
- Testing device
- Computer
- Punch device mirror (Ø2 mm)
- Tweezers
- 1 x Insulation Stripper (Knipex 12 21 180)

1.2.2 Longitudinal cut of SciFi mats

1.2.2.1 Supplies and other Equipment

- Blade (helical disc cutter HSS Ø200 mm x 3 mm)
- Precision pins
- PET-tape
- Machine with 2,5m travel or special device (HD tool)
- Precision (0,05mm over 2,5m)
- Cutting jig (bottom and top plate)

1.2.3 Gluing of module

1.2.3.1 Parts

- 8 x Fibre mats
- 1 x Panel "HE_LHCB_SCIFI_PAN_908411_A_0__LHCb-SciFi-Verbundplatte-top"
- 1 x Panel "HE_LHCB_SCIFI_PAN_908410_A_0__LHCb-SciFi-Verbundplatte-LI"
- 2 x Endplugs "HE_LHCB_SCIFI_PAN_008034_P_1__EndPlug-top"
- 2 x Endplugs "HE_LHCB_SCIFI_PAN_908200_A_0__EndPlugLI-LI-BAR"
- VSCCEL pocket cover "HE_LHCB_SCIFI_PAN_008031_P_0__deckplate_light-injection"
- 16 x Screws ISO 2009 - M3x5
- 2 x Cold box flange "HE_LHCB_SCIFI_PAN_008600_P_0__COLDBOX-FLANGE"
- 16 x Screws ISO 4762 - M3x14
- 4 x Dowel pins ISO 8734 - 5x14 - A -St
- 4 x Side walls "U-Profile" "HE_LHCB_SCIFI_PAN_908412_A_0__U-SHAPE"

1.2.3.2 Supplies and other Equipment

- 1 Gluing Jig „HE_LHCB_SCIFI_VOR_GJ_008200_P_1__KLEBEVORRICHTUNG-PANEL“ with 2 bridges "HE_LHCB_SCIFI_VOR_GJ_008201_D_0__ABSTECKVORRICHTUNG-EPiece-EPlug"
- Dowel pins:
 - o 8 x Ø6x16
 - o 8 x Ø6x5,5
 - o 4 x Ø6x20/M3
 - o 4 x Ø6x13/M3
 - o 8 x Ø6x30
- 1 Gluing and Alignment Jig „HE_LHCB_SCIFI_VOR_GJ_906400_A_0__KLEBE_u._AUSRICHTVORRICHTUNG-PANEL“
- 2 x Bridge „HE_LHCB_SCIFI_VOR_GJ_006402_P_0__BRUECKE_ENDPLUG“
- 1 x Bridge „HE_LHCB_SCIFI_VOR_GJ_006403_P_0__BRUECKE_MITTE“
- 12 x Exzenter „HE_LHCB_SCIFI_VOR_GJ_006404_P_0__Exzenter“
- 12 x Bracket „HE_LHCB_SCIFI_VOR_GJ_006406_P_0__Anschlag“
- 1 Vacuum hood
- 1 Vacuum pump "Leybold DIVAC 2.2 L"
- 1 Vacuum pump "Busch Samos 0200"
- 1 Lifting and Turning device
- Sealer agent Mikon 199 / Release agent Mikon 205
- Araldit AW116 (mix 800gr, 750gr is used per gluing step)
- Light tight silicon
- 1 set glue applicator
- 1 set foam Roller (apply glue on Endplugs)
- 1 toothed spatula (apply glue on mats)
- 1 roll Silicone paper
- 2 x aluminum sheet 520 mm x 90 mm x 1 mm
- 2 x rubber sheet 530 mm x 300 mm x 2 mm
- 1 set syringe
- 1 x Security belt
- 1 x PVC sheet as distance holder (thickness 4mm)

PART CONTROL AND PREPARATION

1.3 ENDPLUGS

The endplugs are one of the main elements concerning module interfaces. The interfaces are: mats/endpieces, mounting, honey comb panel, cold-box flange (for HE_LHCb_SCIFI_PAN_008034_P_1__EndPlug-top) and mats/endpieces, light injection system, survey targets, honey comb panel, cold-box flange (for HE_LHCb_SCIFI_PAN_908200_A_0__EndPlugLI-LI-BAR). Errors in production will interfere with these interfaces.

Two of each endplug type (2 x light injection and 2 x frame mounting) are needed for one module.

Both endplug types follow the same preparation steps. As shown in “**Error! Reference source not found.**”, check or prepare the following:

- Check the depth of the step in the endplug (5.7mm +0.05/-0). (indicated by the red box)
- Surfaces indicated by the red arrows have to be roughened and cleaned with isopropanol for later gluing.

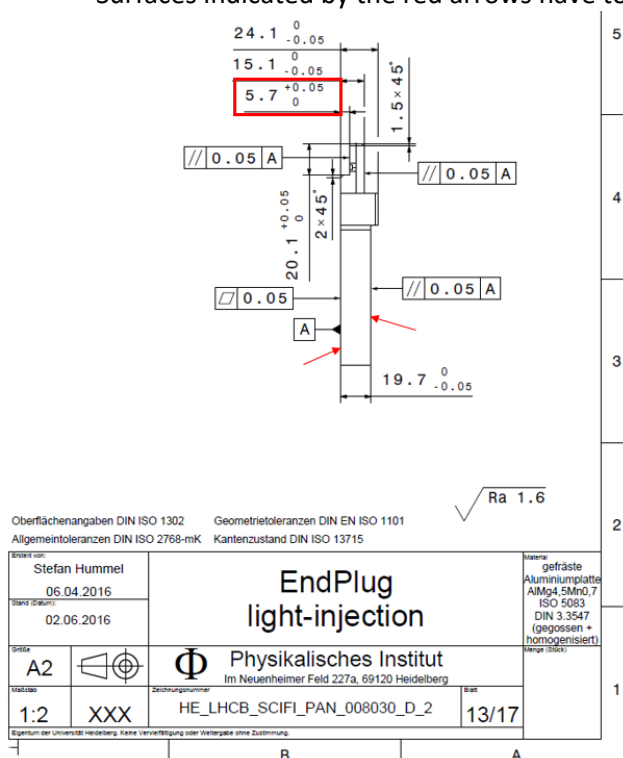

Figure 1 example of a manufacturing drawing of the Endplug light injection

- Check for sharp edges. Sharp edge could injure people during handling or damage the fibre mats.
- Check precision holes for dimension and that they are free of obstructions.
- Check overall dimensions.



Figure 2 both endplugs types (old version)

1.4 SciFi-MATS

The SciFi mats are the essential component of the detector. They have to be handled very carefully otherwise cracks and loose fibres can occur and will degrade the performance of the detector.

The inspection record from the winding centre has to be checked. Every mat has a complete QA data set made by the winding center, grading each of in quality groups from A to D. Modules will be produced with mats of the same grade.

- Check size of fibre mat pins (nominal size 3 mm $\pm 0,1$)
- Visually inspect the endpiece. Check that it is free of glue residue
- Visual inspection quality of gluing of the light tight polyimide foil. No loose foil!

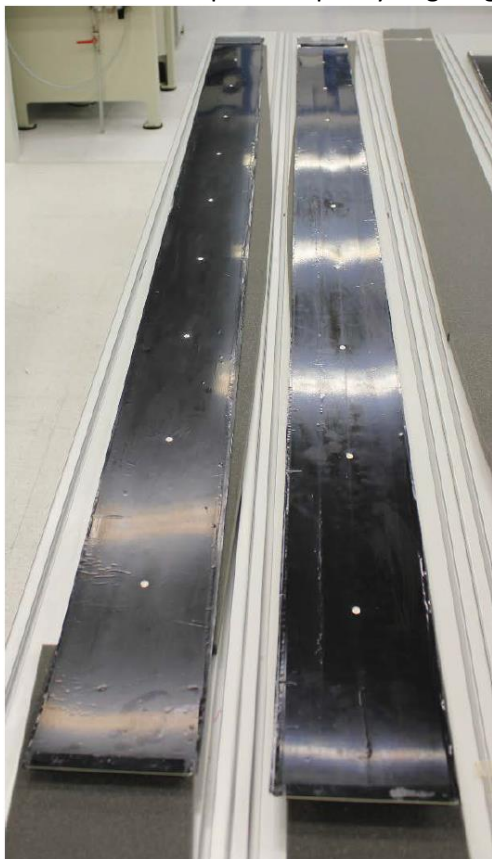

Th. Kirn, M. Wlochal

Figure 3 SciFi mat with mat pins up

1.5 COLD-BOX FLANGE

The cold-box flange (HE_LHCB_SCIFI_PAN_008600_P_0__COLDBOX-FLANGE) is the interface from endplug to cold-box with the SiPM readout. It is defined with dowel pins to the endplug

“HE_LHCB_SCIFI_PAN_008034_P_1__EndPlug-top” and screwed to both of them. A black or light tight silicone is additionally used to ensure humidity and light tightness. Two cold-box flanges are needed for one module, one at either end.

To be checked:

- Check overall dimension and specs.
- Check surface quality for flat gasket and silicon bonding. No metal burs on the surfaces or anything else that will interfere with sealing the cold-box.

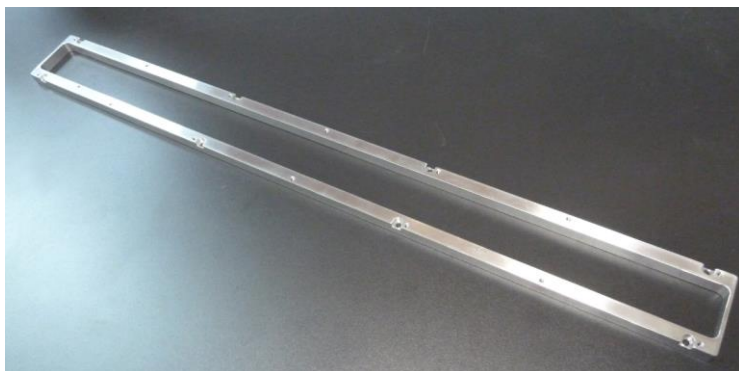

Figure 4 Cold-box flange

1.6 HONEY COMB PANEL

The honeycomb panel gives stiffness to the module once both panels are glued together. It is composed of one layer of honeycomb core, a layer of carbon fibre reinforced polymer (CFRP), and a light tight polyimide foil. The two panels used are slightly different. One is for the face where the mat pins are, one other for the flat side of the mats. They also have different cutouts in the carbon fibre “tongue” according to the endplugs.

To be checked:

- Check overall dimensions.
- Check cut-outs for pins/LIS/Mounting
- That they are dust free. If not, clean with vacuum cleaner
- Visual inspection quality of gluing of the light tight polyimide foil. No loose foil at the edges.

After the controls, rough the polyimide foil an approx. 20mm wide surface at the edges of the panels on both edges and both sides for the later gluing of the side walls.

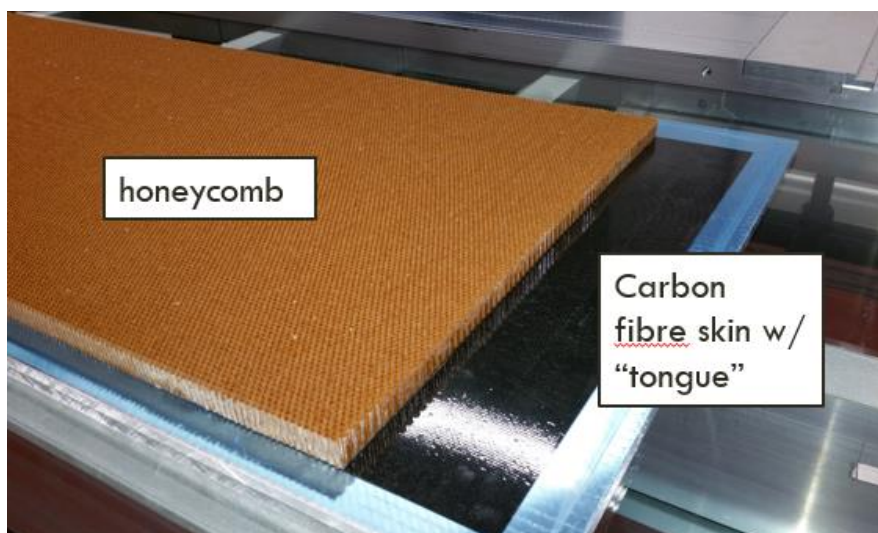

Figure 5 Honey comb panel

1.7 SIDEWALLS (U-PROFILE)

The sidewalls close the side of the module, provides mechanical protection to the mats and improve the light tightness. They are made of CFRP with an additional light tight polyimide foil.

To be checked:

- Check overall dimensions
- Visual inspection quality of gluing of the light tight polyimide foil



Figure 6 Sidewalls

2 TOOLING AND JIGS

2.1 GLUING JIGS

There are two templates used for the main gluing steps. The templates must be cleaned, and be rid of any residual glue, dirt or dust. A sealer agent Mikon 199 and then a non-stick agent Mikon 205 must be applied to both at regular intervals. The non-stick agent has to be refreshed after every 3-5 assemblies. This is a 12 hour process. The fumes from this are quite aggressive and an air filter must be worn over the nose and mouth during application while the room is ventilated.

To be checked:

- Cleanness of jigs (Never use isopropanol! This will remove the non-stick agent!!)
- Check that the jig is free of damage and scratches, where the glue might bond
- Have the correct dowel pins available and within reach
- Bridges available

2.1.1 Gluing jig

The gluing jig “HE_LHCb_SCIFI_VOR_GJ_008200_P_1__KLEBEVORRICHTUNG-PANEL” is a single 5m aluminum alloy plate machined on a 7m machine. The main function of it is to insure the alignment of all parts and the flatness of the mats during the gluing process.

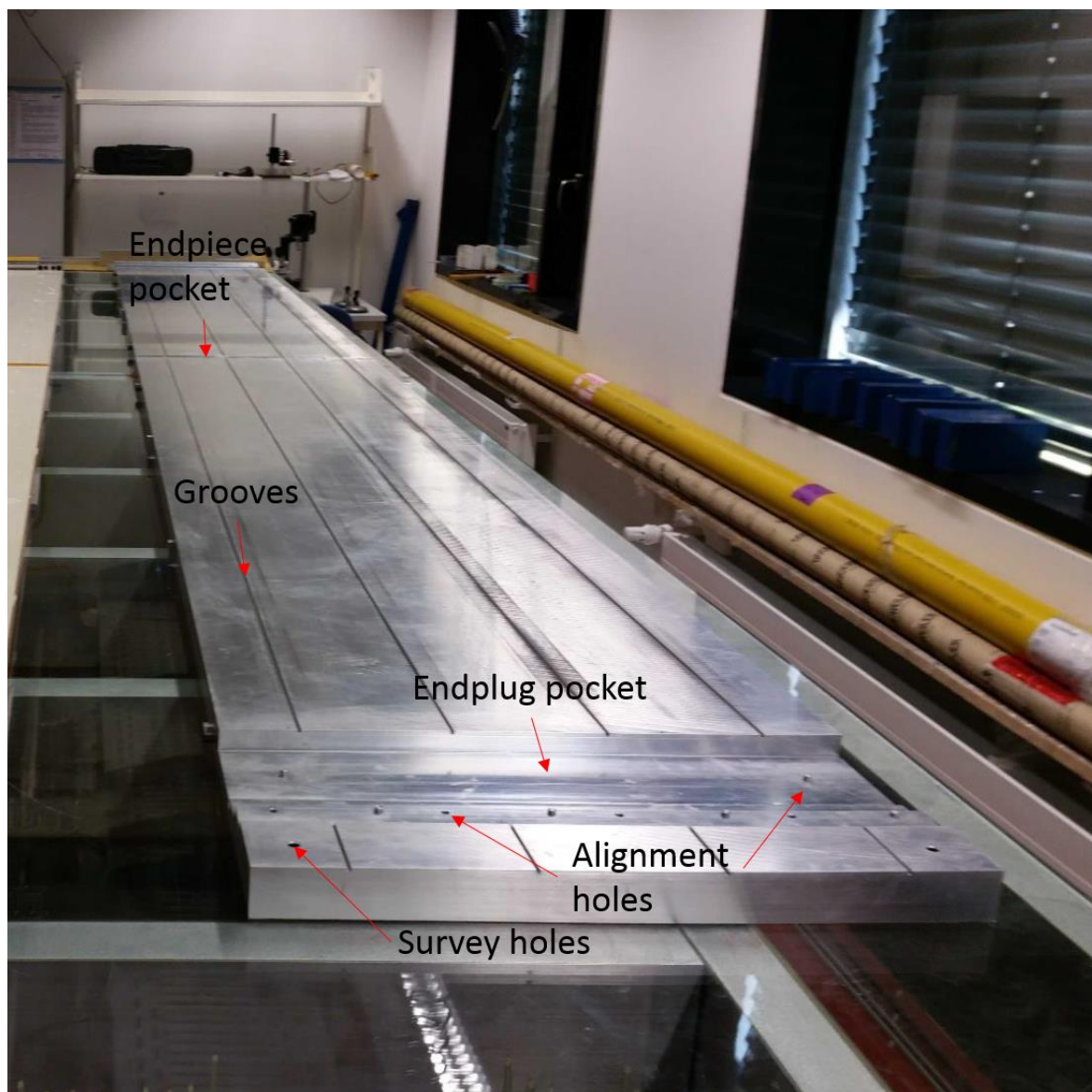

Figure 7 Overview gluing jig

2.1.2 Gluing and alignment jig

The gluing and alignment jig „HE_LHCb_SCIFI_VOR_GJ_906400_A_0__KLEBE_u._AUSRICHTVORRICHTUNG-PANEL is essentially a single flat 5m aluminum alloy plate machined on a 7m machine. As after the first gluing step the half module is still flexible, the jig permit to realign the half module via bridges and pins after the handling.

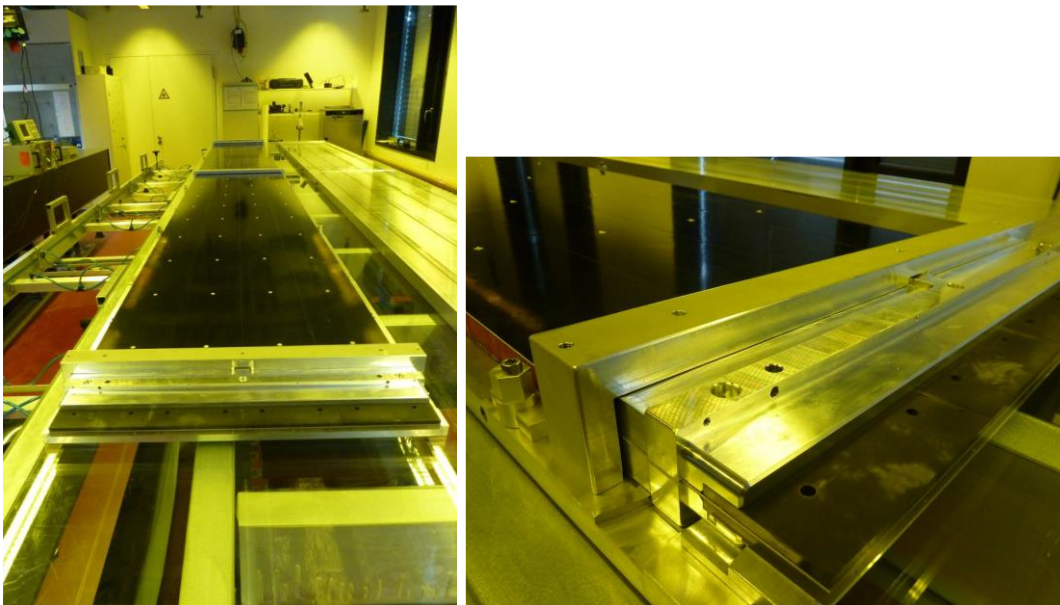

Figure 8 Overview gluing and alignment jig (with half module on it)

2.2 LIFTING AND TURNING DEVICE

The lifting and turning device is an aluminum structure with suction pads and sliding rails for the handling of the module during and after the gluing process. The module is fixed to it by screws into the endplugs and 12 suction pads. To slide the module off, the lifting and turning device is also equipped with 4 sliding rails actioned with pressurized air.



Figure 9 Overview lifting and turning device

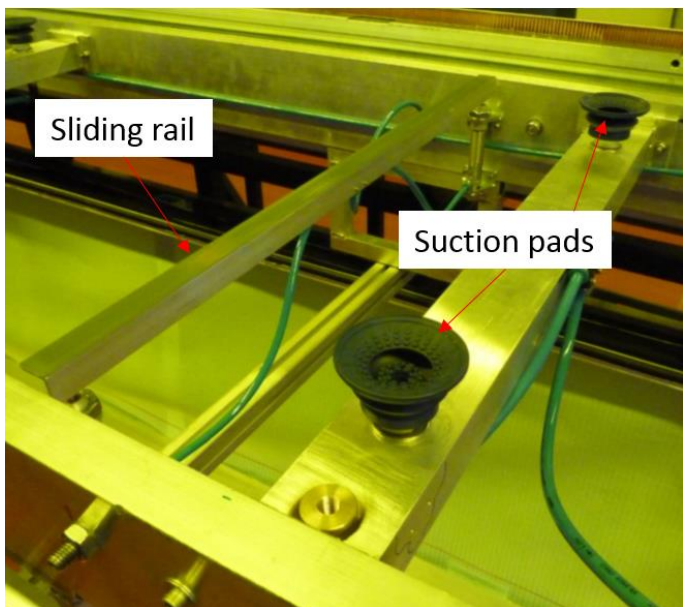

Figure 10 Detail lifting and turning device

2.3 VACUUM HOOD

The vacuum hood is an aluminum structure covered with a fibre reinforced foil. It permits us to apply a homogenous pressure over the complete module will the glue is curing.



Figure 11 Overview vacuum hood

3 LIGHT INJECTION SYSTEM

3.1 LIGHT BARS

The light injection system consists of fibre-optic cables glued into aluminum bars as support. The fibre insulation jacket is removed over the last 140mm of the fibre, in order to expose the core, and then glued to the light bar, then the over length of the fibre sticking out of the light bar is cut and polished. The uninsulated area of the fibre is scratched which will be the light emitting area of the system, and provides a nearly uniform source.

The fibre is PMMA fibre core with a fluoropolymer cladding and a PE buffer coating. To permit the radial light emitting of the fibre, the fluoropolymer cladding has to be scratched. Insuring the precise scratching and positioning of the fibre, it is glued to a groove in the light bar. This groove has two different widths, one with a width of 2.2mm and one with 1mm, corresponding to the jacket and core diameter. After gluing, the uninsulated core of the fibre has to stick slightly out of the end of the bar by a couple mm to permit cutting and polishing of the end of the fibre. At this end, a mirror will be glued to increase the light yield. Scratching of the fibre is done with a Vernier height gauge while the light bar is hold on a precise height by a simple holder.

3.1.1 Parts needed per light bar

- 1 x HE_LHCB_SCIFI_PAN_008100_P_0__LI-BAR
- 1 x 500mm fibre
- 1 x mirror (Al Mylar foil)

3.1.2 Equipment needed

- 1 x Vernier height gauge (scratching device)
- 1 x Laser device (Blake specs)
- 1,5 g glue EPO-TEK 302-3M
- 1 x Gluing jig
- 4 x Al-bars protected with PET -tape
- 1 x Syringe with tip
- 1 x Tweezers
- 1 x Punching device ($\varnothing 2$ mm)
- 1 x Insulation Stripper (Knipex 12 21 180)

3.1.3 Production description

The production of one set for a module (8 pieces) takes approximately 45 minutes of handwork and needs one technician.

3.1.3.1 Prepare the fibre by cutting pieces with 500mm length. Remove 140mm of the insulation. Clean grooves with isopropanol and prepare 12 g of glue EPO-TEK 302-3M in a syringe.

3.1.3.2 Apply the EPO-TEK 302-3M glue into the grooves over the whole length of the light bar with the syringe. The uninsulated part and also a short length of the PE coated area will be glued to the light bar.

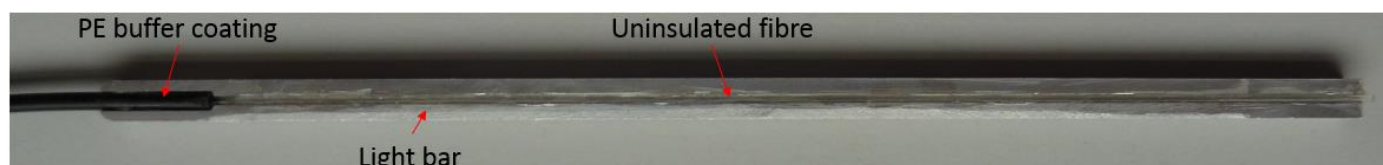

Figure 12 Light bar with fibre

3.1.3.3 By positioning the fibre in the light bar, be sure that the insulated part of the fibre fills totally the wider groove so that the end of the fibre core sticks out at the end of the light bar.

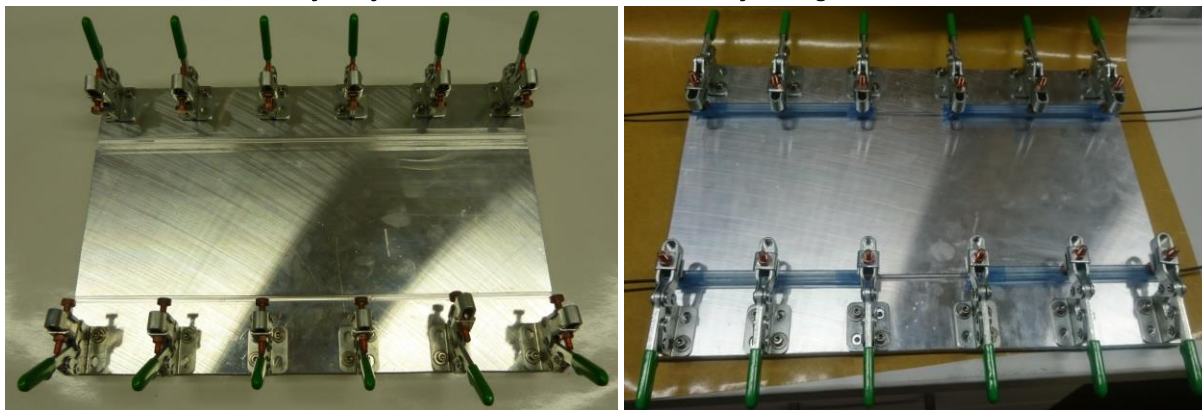

Figure 13 One of the gluing jig for the light bars open and closed/equipped

3.1.3.4 Place the light bar in the gluing jig, place on the top the al-bars protected with PET-tape and close the clamps. The curing time is 24 hours at 23°C.



Figure 14 Cured light bar with fibre

3.1.3.5 The scratching of the fibre has to be done in a darkened room to be able to see directly the result by eye during light is injected to the fibre with the laser device. Before starting, a control of the height of the Vernier height gauge with respect to the middle of the fibre in the light bar is necessary. Scratch the fibre with a continuous movement so that light is coming out over the whole scratching area. In "Figure 15" the area and its delimitation is shown.

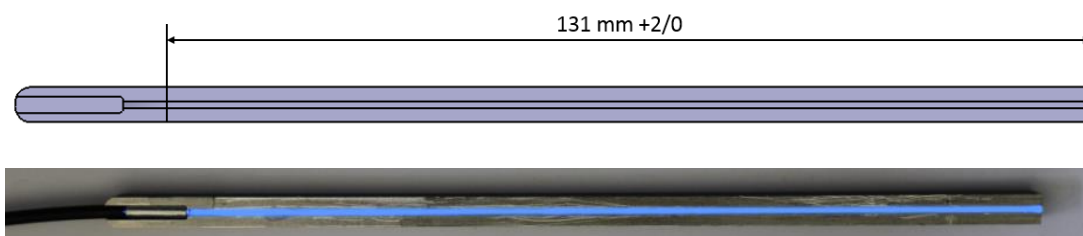

Figure 15 Scratching area; scratched light bar

3.1.3.6 The over length of the fibre can now be cut with a scalpel and the whole surface polished and cleaned for gluing. Apply a drop of EPO-TEK 302-3M and place the mirror using the tweezers at the end of the fibre. Apply pressure and let cure 24 hours.

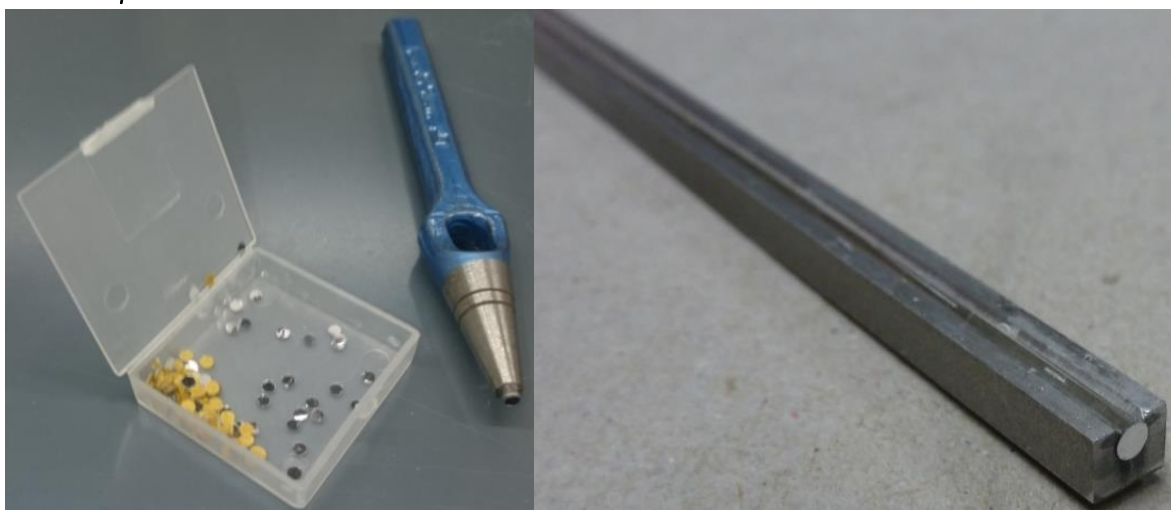

Figure 16 Box with ready to use mirrors and punching device; glued mirror on end of fibre

3.1.4 QA

Currently, the light bars are placed in the Sr-90 Fibre Mat QA setup and the light output is checked for amplitude and uniformity in the SiPM channels. A new setup is being developed using a photodiode array such that the technicians can test devices themselves, rather than the students.

3.2 LIGHT BARS IN ENDPLUG

We have one endplug and four mats per side of the module. Each light bar has a corresponding mat where the light is injected. Each of the two pockets will house a laser mezzanine card which contains two VCSELs to provide the light for two Light bars. In the “Figure 17” the different relevant geometries for this step are shown. First we have grooves where the light bars take place (orange), routing grooves to guide the cable until the VCSEL pockets (blue) and then the VCSEL pockets (beige).

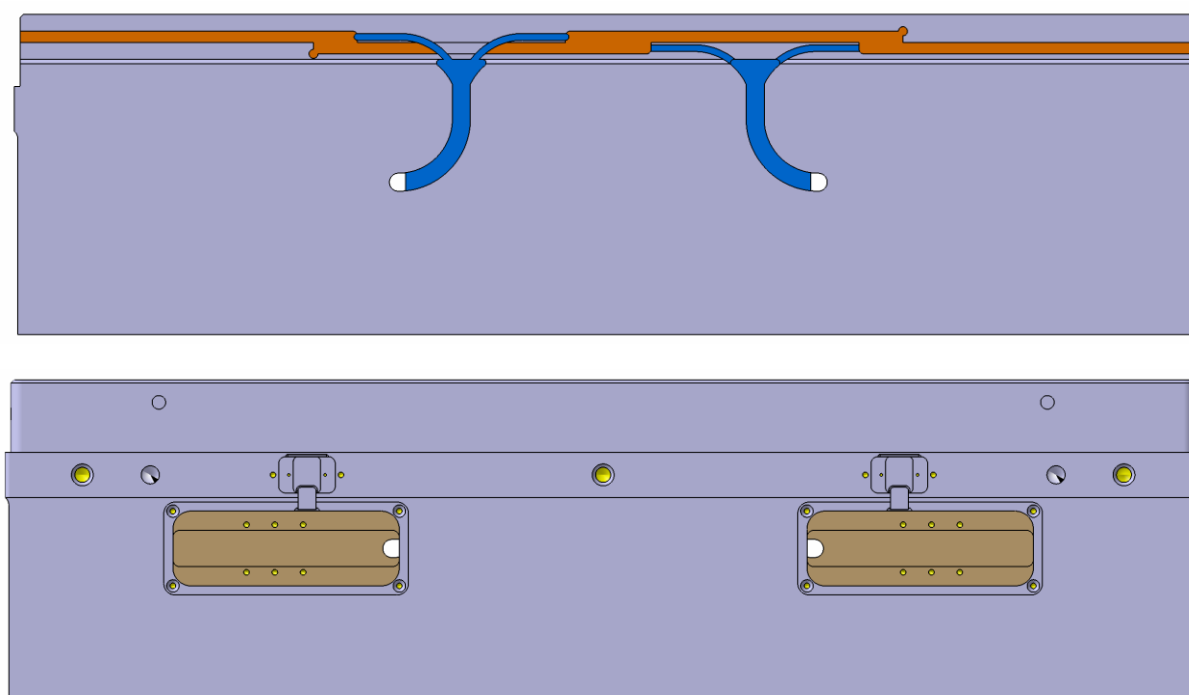

Figure 17 Light injection features of the endplug “Light injection” (top figure mat side facing up, bottom figure outside)

3.2.1 Pieces needed per endplug

- 4 x glued light bars
- 2 x Soft tubing $\varnothing 5 \times 30$
- 1 x Endplug "HE_LHCb_SCIFI_PAN_008030_P_2__EndPlug_light-injection"

3.2.2 Equipment needed

- Araldit AW116 (30 g)
- 1 x Syringe
- 2 x Teflon spacer
- 3 x Fastening clamps
- 1 x Al-bar protected with PET-tape for clamping the bars flat

3.2.3 Production steps

The production of one set (2 endplugs with 4 light bars each) takes approximately 45 minutes and needs one technician.

3.2.3.1 Prepare the endplugs by roughening the groove for the light bars and the light bars on the opposite side of the fibres, then clean everything with isopropanol. To avoid any damaging of the light injection system at a later stage, it is necessary to also roughen all gluing surfaces of the endplug at this point (CFRP and fibre surfaces too). Prepare the glue Araldit AW116 in a syringe.

3.2.3.2 Start by making two sets of two light bars. To prevent the cables jumping out later, assemble the set with the shrinking tube (without applying heat!!!) and thread it into the routing groove until the VCSEL pocket as shown in "Figure 18".

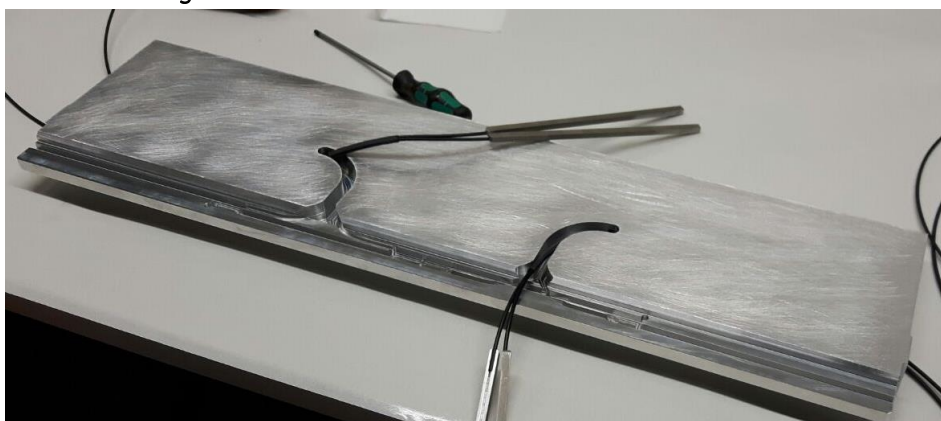

Figure 18 Sets of light bars thread into endplug

3.2.3.3 Apply drops of glue into the grooves for the light bars as shown in "Figure 19".

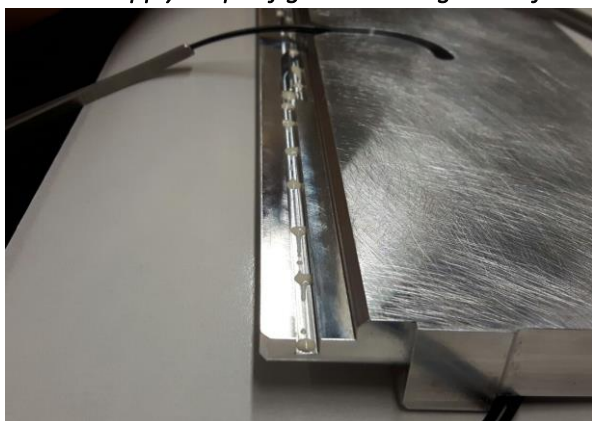

Figure 19 Glue in groove for light bar

3.2.3.4 Place the corresponding light bars into the grooves and take care of the right order. The cable are crossing under light bars in the grooves (see Figure 20).



Figure 20 Crossing of cables and light bars

3.2.3.5 Apply glue into the routing grooves to create the strain relief of the cables as shown in "Figure 21".



Figure 21 Strain relief of the cables of the light bars

3.2.3.6 Place the Teflon space holder into the routing groove to insure that the cables sticks to the glue bath as shown in "Figure 22". Little to no pressure is needed at this point, to ensure the fibre in the cables are not damaged.

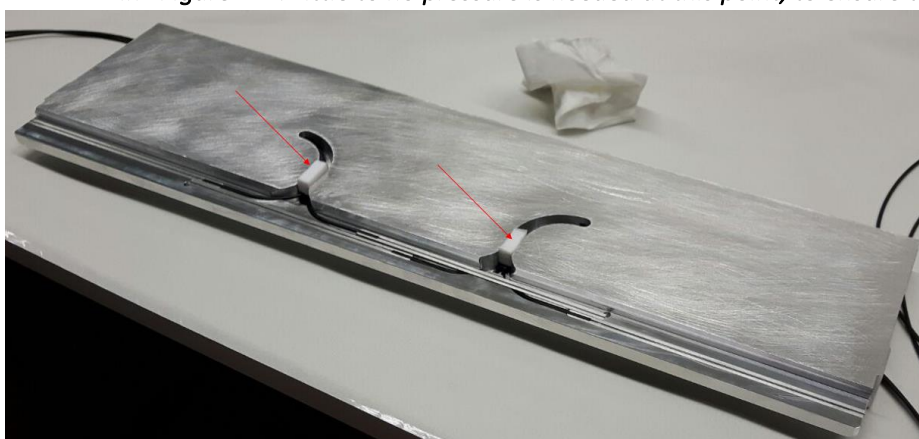

Figure 22 Teflon space holder into the routing groove

3.2.3.7 Place the Al-bar protected with PET-tape over the whole length of the light bars press everything together with the fastening clamps. Let cure the glue at least 12 hours.

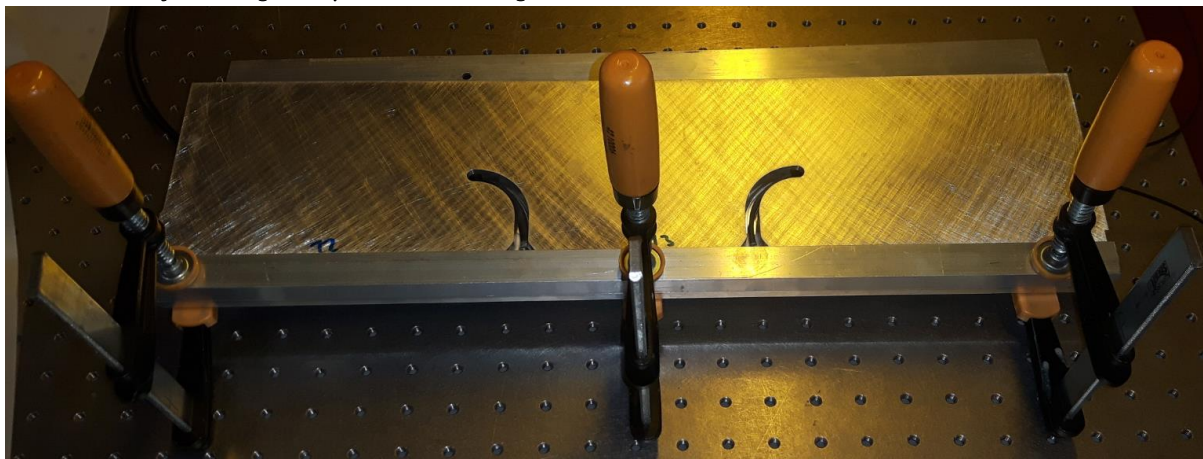

Figure 23 Fastening clamps on Al-bar (the Teflon spacers are not shown on this picture)

3.2.3.8 Register of endplug in database.

3.2.3.9 Test of functionality and broken fibres.

4 SCIFI-MAT LONG CUTS

The cutting of one mat takes approximately 30 minutes and needs mainly one technician, a second is needed during the handling of the mat and the tooling.

The mats are produced over width and have to be cut to the nominal width of 130.65 mm (symmetric from the pin central axis). After the preparation described in “SciFi-mats” on page 9 the longitudinal cut can be performed.

4.1.1 Equipment needed

- 1 x Blade (helical disc cutter HSS $\varnothing 200$ mm x 3 mm)
- 4 x Precision pins
- PET-tape
- Machine with 2.5m travel or special device (HD tool); Precision (0.05mm over 2.5m)
- Cutting jig (bottom and top plate)

4.1.2 Production description

4.1.2.1 *Clean the cutting device and unpack a mat. The mat can be placed onto the lower plate of the cutting device*

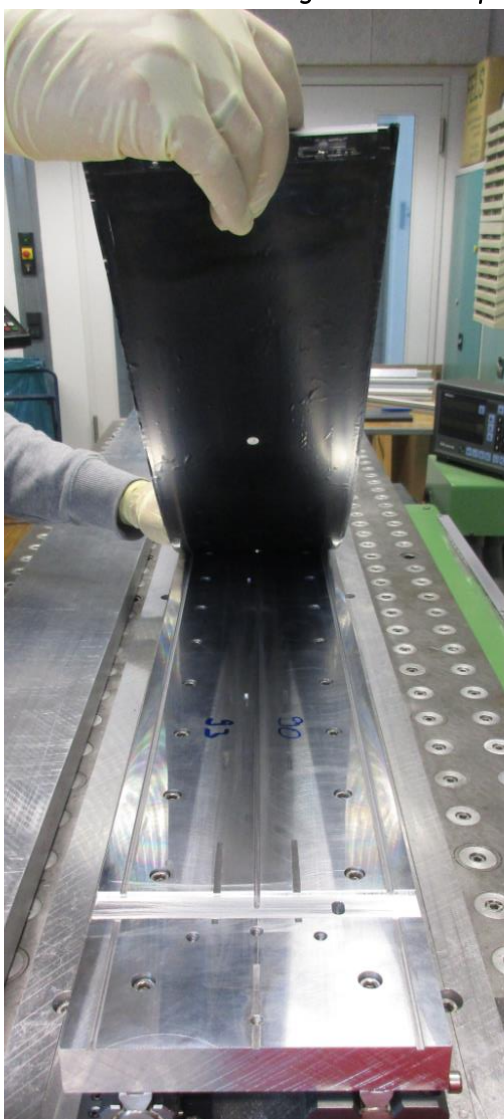

Figure 24 placing uncut mat into cutting jig

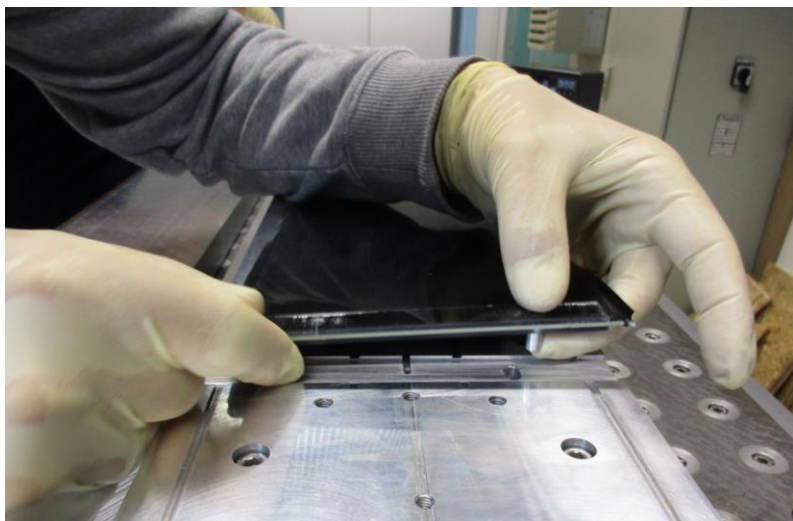

Figure 25 Dowel pins for positioning the endpieces with respect to the jig



Figure 26 Insuring pins of mat going into the alignment groove in the jig

4.1.2.2 Place cover plate over mat. Screw it to the lower plate to insure enough pressure on the mat and lock the position (Figure 27).

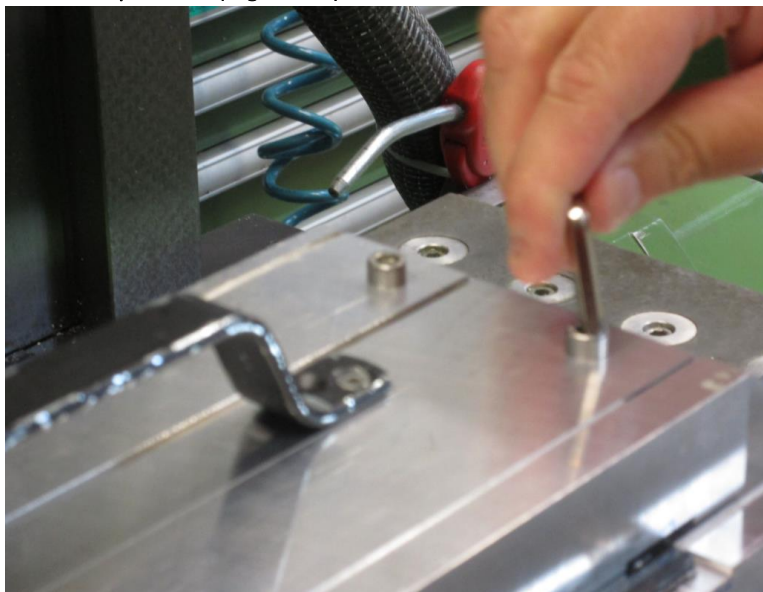

Figure 27 Upper plate screwed to the lower plate

4.1.2.3 Remove handles of upper plate.

4.1.2.4 To avoid the cut part of the mat vibrating during the cutting procedure, fix it to the lower plate with tape.



Figure 28 Tape on cut sides of the mats

4.1.2.5 *Cut the mat. 1200 min^{-1} , feed rate 600 mm/min (at endpieces and immersing 300 mm/min)*



Figure 29 cutting one side of the mat

4.1.2.6 *Clean the mat from cutting residues. Remove the mat from jig.*

4.1.2.7 *Fill entry in database.*

5 GLUING OF MODULE

5.1 1ST GLUING STEP

The gluing of the first step takes approximately 90 minutes and needs two technicians, a third person is needed for assistance.

Before starting the gluing, make sure that all the previous described steps were done.

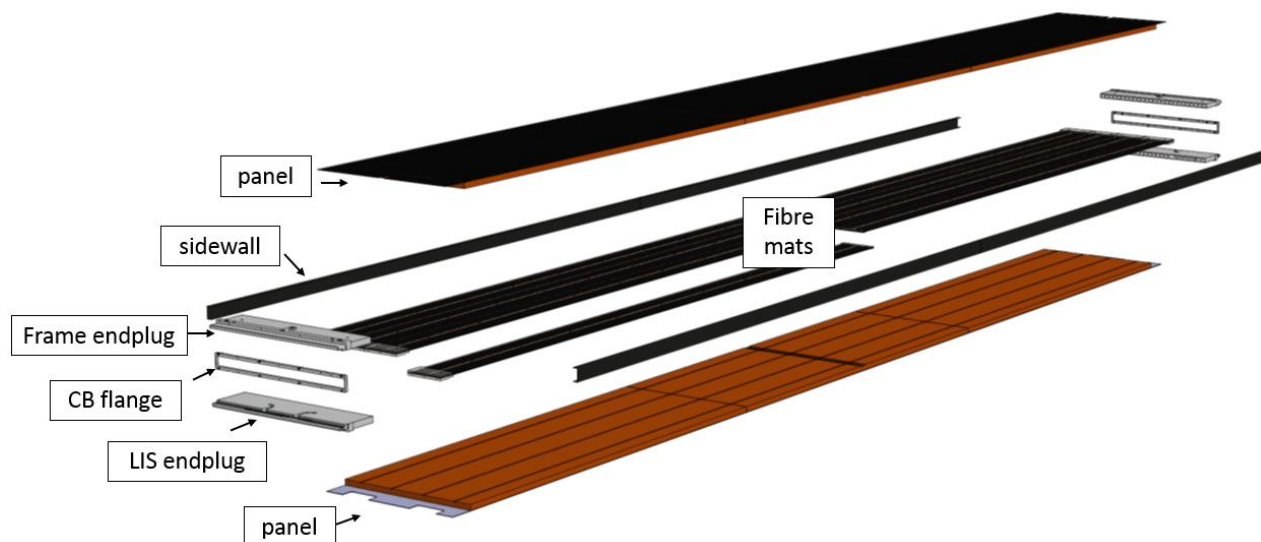

Figure 30 Overview module

5.1.1 Parts

- 8 x Fibre mats
- 1 x Panel "HE_LHCB_SCIFI_PAN_908410_A_0_LHcb-SciFi-Verbundplatte-LI"
- 2 x Endplugs "HE_LHCB_SCIFI_PAN_008034_P_1_EndPlug-top"
- 2 x Endplugs "HE_LHCB_SCIFI_PAN_908200_A_0_EndPlugLI-LI-BAR"

5.1.2 Equipment

- 1 Gluing Jig „HE_LHCB_SCIFI_VOR_GJ_008200_P_1_KLEBEVORRICHTUNG-PANEL“ with 2 bridges "HE_LHCB_SCIFI_VOR_GJ_008201_D_0_ABSTECKVORRICHTUNG-EPiece-EPlug"
- Dowel pins:
 - o 8 x $\varnothing 6 \times 16$
 - o 8 x $\varnothing 6 \times 5,5$
 - o 4 x $\varnothing 6 \times 20 / M3$
 - o 4 x $\varnothing 6 \times 13 / M3$
- 1 Lifting and Turning device
- 1 Vacuum hood
- 1 Vacuum pump "Leybold DIVAC 2.2 L"
- 1 Vacuum pump "Busch Samos 0200"
- Sealer agent Mikon 199 / Release agent Mikon 205
- Araldit AW116 (mix 800gr, 750gr is used per gluing step)
- 1 set glue applicator
- 1 set foam Roller (apply glue on Endplugs)
- 1 toothed spatula (apply glue on mats)
- 1 roll Silicone paper
- 2 x aluminum sheet 520 mm x 90 mm x 1 mm
- 2 x rubber sheet 530 mm x 300 mm x 2 mm

- 1 set syringe

5.1.3 Preparation

Make a dry assembly as a last control of fittings and equipment (without glue). Record defined position of mats in database.

Remove any dust from the template with a vacuum (no isopropanol, will remove release agent Mikon 205), or dry cloth. Clean the surface of the Mats with isopropanol.

5.1.4 Production description

5.1.4.1 Place the 8 dowel pins $\varnothing 6 \times 16$ for the in the jig at the positions of the endpieces read-out side and 8 dowel pins $\varnothing 6 \times 5.5$ at the positions of the endpieces mirror side. Place 4 dowel pins $\varnothing 6 \times 13$ at the positions of the endplugs.

5.1.4.2 Prepare 800 g of glue Araldit 116.

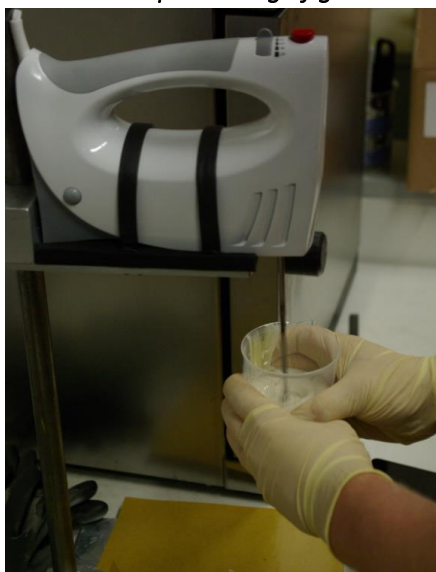

Figure 31 Mixing Araldit 116

5.1.4.3 Spread glue on a silicon paper and roll over it with the roller until it is evenly impregnated (Figure 32). Apply glue (Glue Araldit 116) with foam roller on endplugs “HE_LHCb_SCIFI_PAN_008034_P_1__EndPlug-top” at the gluing surface to the mats and to the surface to the endpieces. Apply with a syringe a line of glue to the inner edge of the surface for the endpieces (Figure 34).



Figure 32 Glue on silicon paper



Figure 33 Applying glue with the roller to the endplug

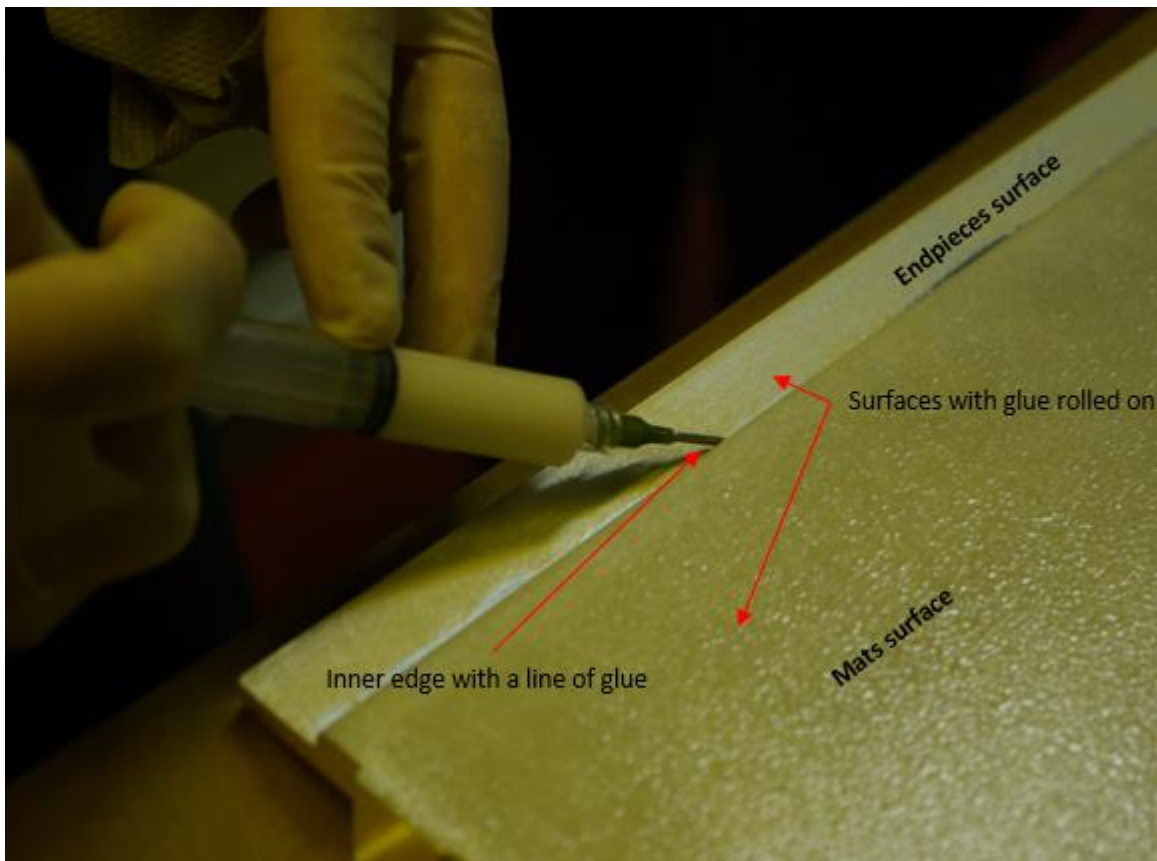

Figure 34 Applying glue on the inner edge of the endpiece face

5.1.4.4 Before placing the endplugs into the jig, clean all the glue residues which could come in contact with the gluing jig. Place endplugs in the gluing jig and take care of the positioning with the dowel pins. If due to the handling some glue is removed from the gluing surface (this is common), reroll the concerned area.



Figure 35 Endplug in gluing jig

5.1.4.5 Place Mats in gluing jig and take care of the positioning with the dowel pins.

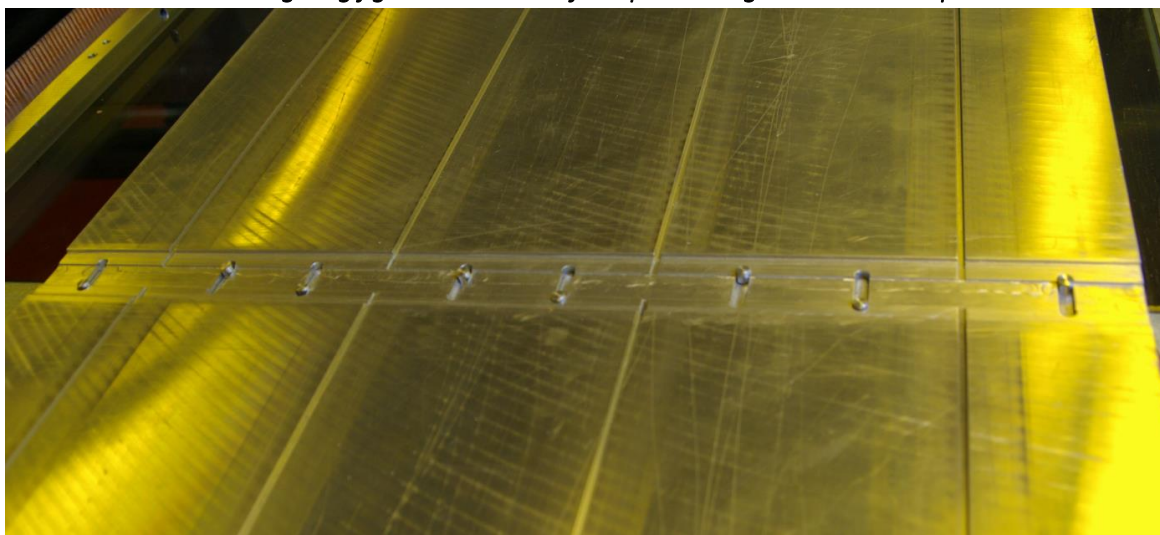

Figure 36 Dowel pins for endpieces mirror side



Figure 37 Placing mats to the gluing jig



Figure 38 Control fitting of the mats before glue application

5.1.4.6 Apply glue (Glue Araldit 116) with foam roller on endplugs “HE_LHCB_SCIFI_PAN_908200_A_0_EndPlugLI-LI-BAR” to the gluing surface to the mats and not to the surface to the endpieces/of the light bars. If necessary clean this surface free of glue residues.

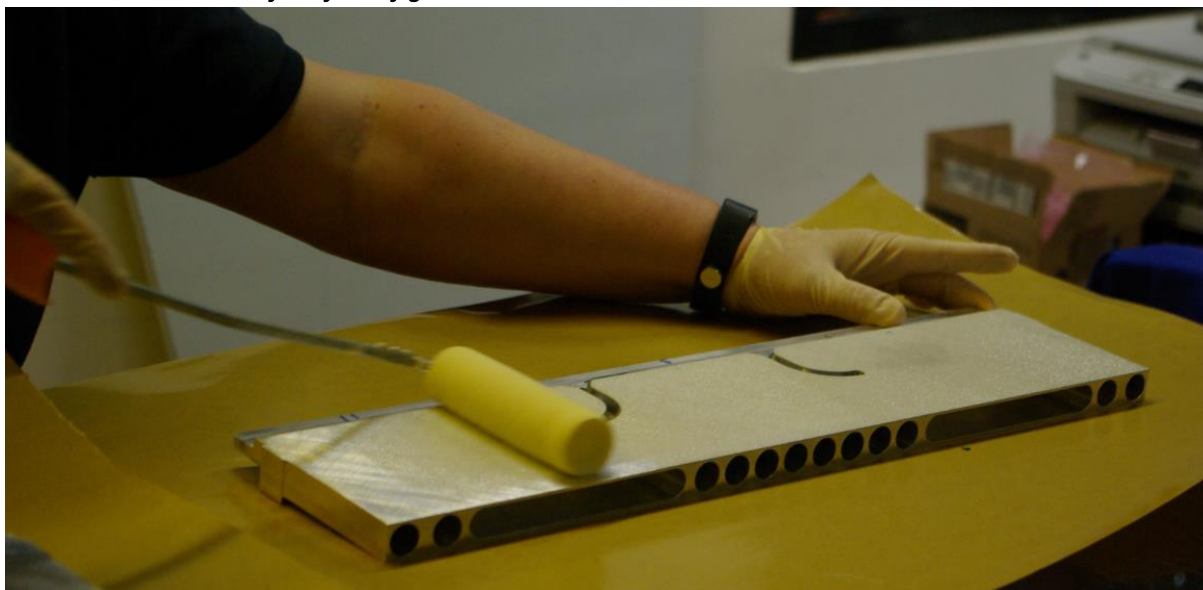

Figure 39 Applying glue with the roller to the endplug

5.1.4.7 Apply glue with a syringe to the inner edge of the endpieces.

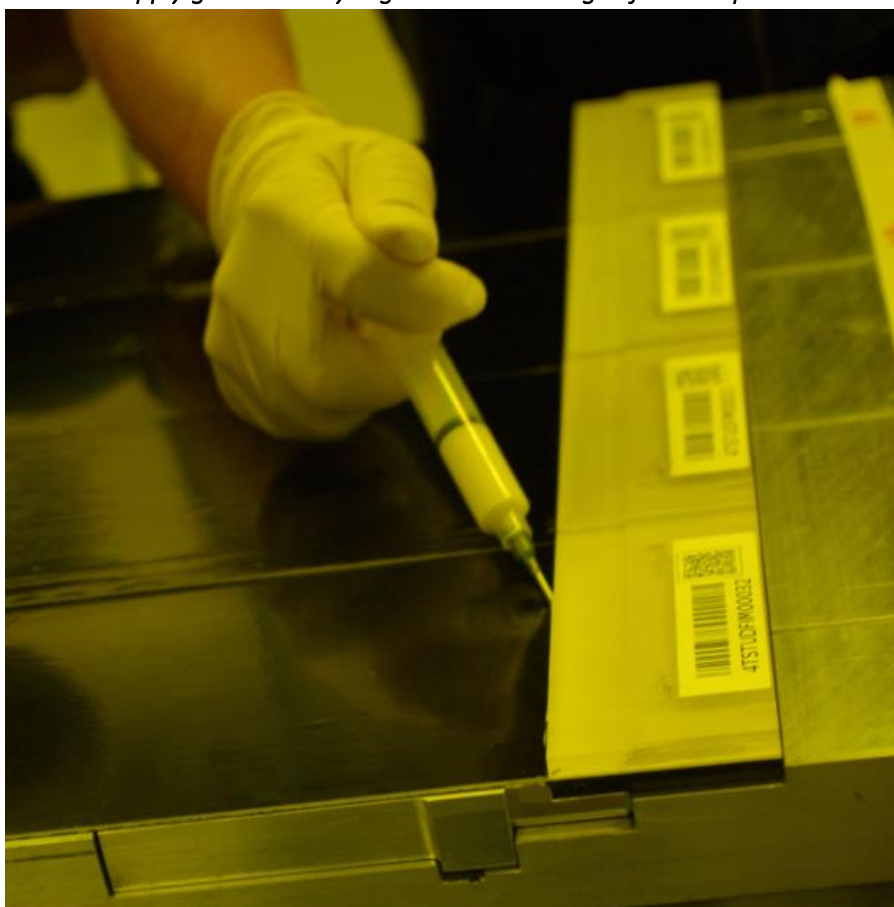

Figure 40 Applying glue with a syringe to the endpieces

- 5.1.4.8 Place endplugs (Figure 41) and align with bridges
“HE_LHCB_SCIFI_VOR_GJ_008201_D_0_ABSTECKVORRICHTING-EPiece-EPlug” to the endpieces and dowel pins 4 x \varnothing 6x20/M3 and 4 x \varnothing 6x13/M3. After the dowel pins are well placed, remove the M3 screws. (Figure 42 and Figure 43)

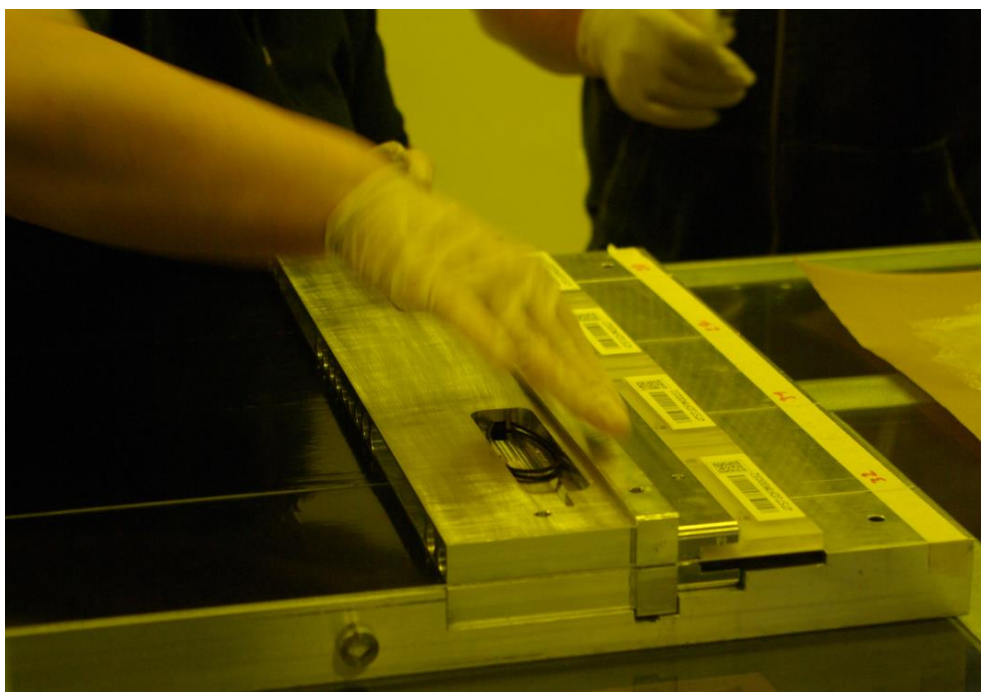

Figure 41 Endplug on mats

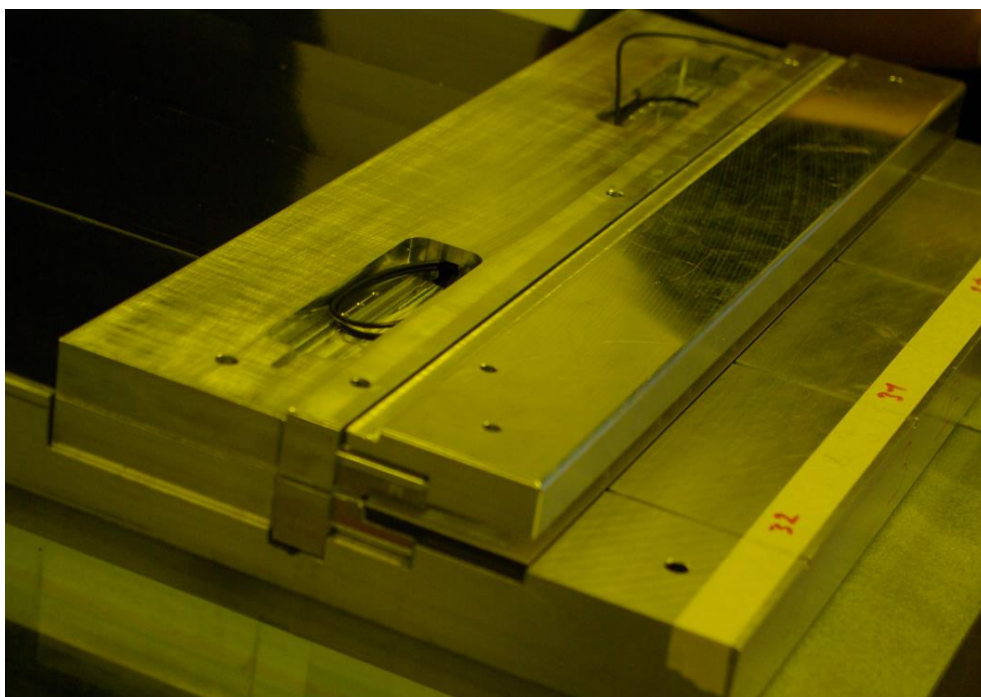

Figure 42 Bridge “HE_LHCB_SCIFI_VOR_GJ_008201_D_0_ABSTECKVORRICHTING-EPiece-EPlug”

Note: on Figure 41 and Figure 42 you can see tape on the jig with ending numbers of the mats written on it to remind the respective positions of the mats after the record and dry assembly)

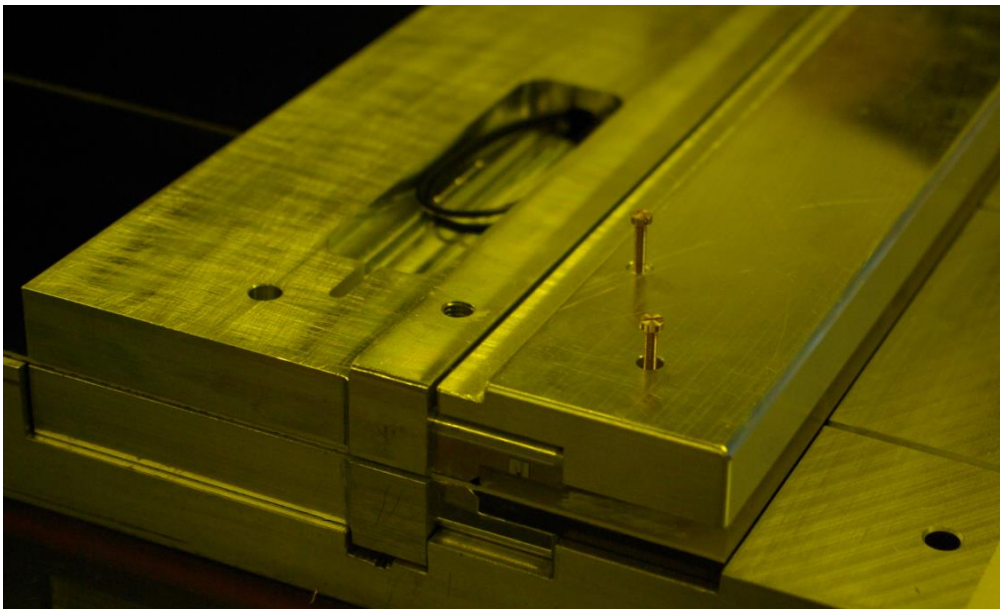

Figure 43 Insure proper fitting of the dowel pins into the endplugs and endpieces

5.1.4.9 One person apply the glue (Glue Araldit 116) on each mat with the glue applicator in sinuous lines and the second follows by spreading the glue with the toothed spatula. Not spread until the borders of each mat (see Figure 45)!



Figure 44 applying the glue with the glue applicator in sinuous lines

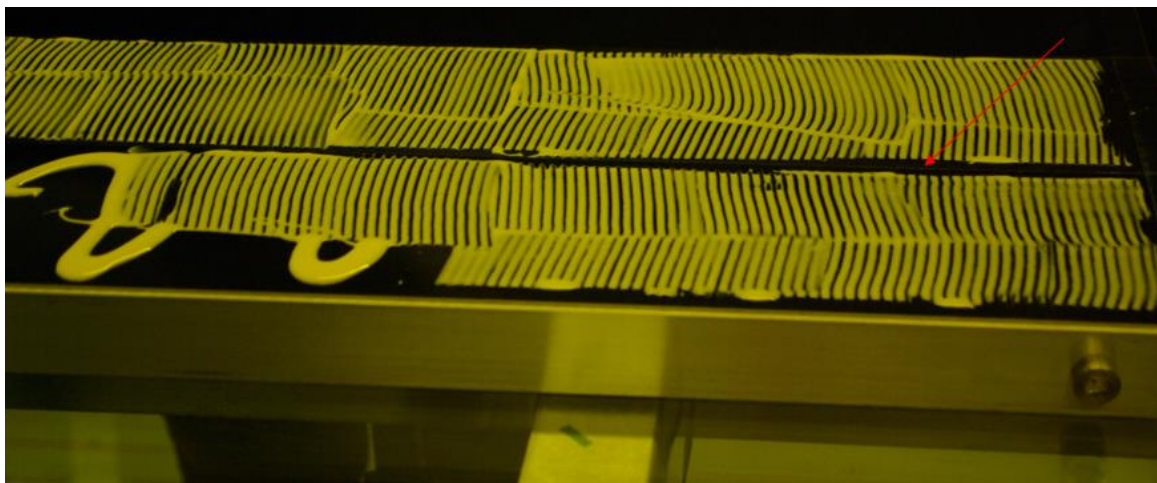

Figure 45 Spreading of the glue with the toothed spatula

5.1.4.10 With the roller apply glue to the gluing surface of the endplug “HE_LHCB_SCIFI_PAN_908200_A_0__EndPlugLI-LI-BAR” as shown in Figure 46

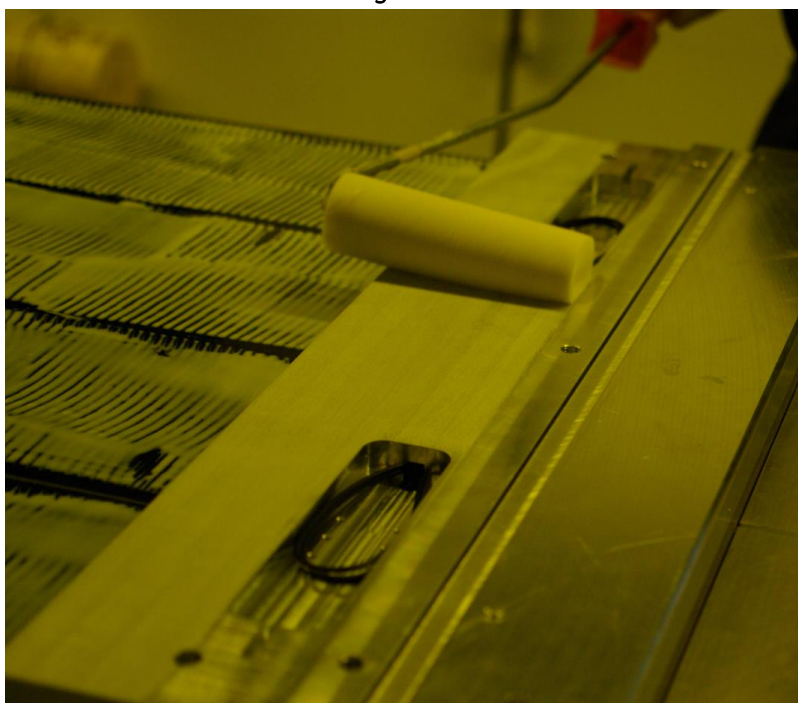

Figure 46 Glue on endplug “HE_LHCB_SCIFI_PAN_908200_A_0__EndPlugLI-LI-BAR”

5.1.4.11 Take the honey comp panel “HE_LHCB_SCIFI_PAN_908410_A_0_LHCB-SciFi-Verbundplatte-LI” with the “Lifting and Turning device” by using vacuum with the vacuum pump “Leybold DIVAC 2.2 L” and place it on the top of the gluing jig with rough positioning by taking for reference the cut out in the middle for the endpieces mirror side (Figure 47).

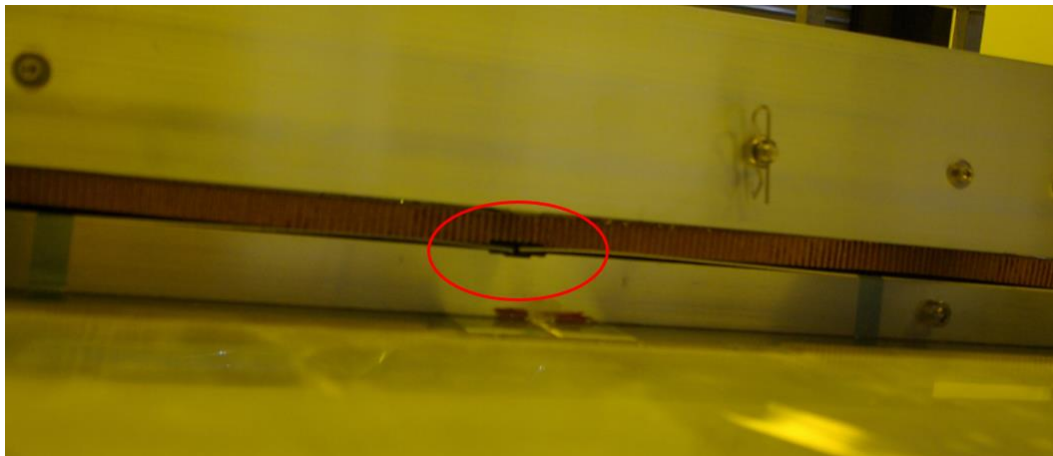

Figure 47 Alignment of the Panel with respect to the endpieces mirror side

5.1.4.12 Remove vacuum and remove the “Lifting and Turning device”. Control by eye the proper fitting of the panel and correct it if necessary. Place the ledges on the sides of the jig for the final alignment over the width (under development).

5.1.4.13 Place silicon paper on junction carbon fibre sheet and End plugs to avoid glue sticking to vacuum hood.

5.1.4.14 Place the aluminum sheet 520 mm x 90 mm x 1 mm over the pocket of the VSCEL to avoid the vacuum hood be sucked in.

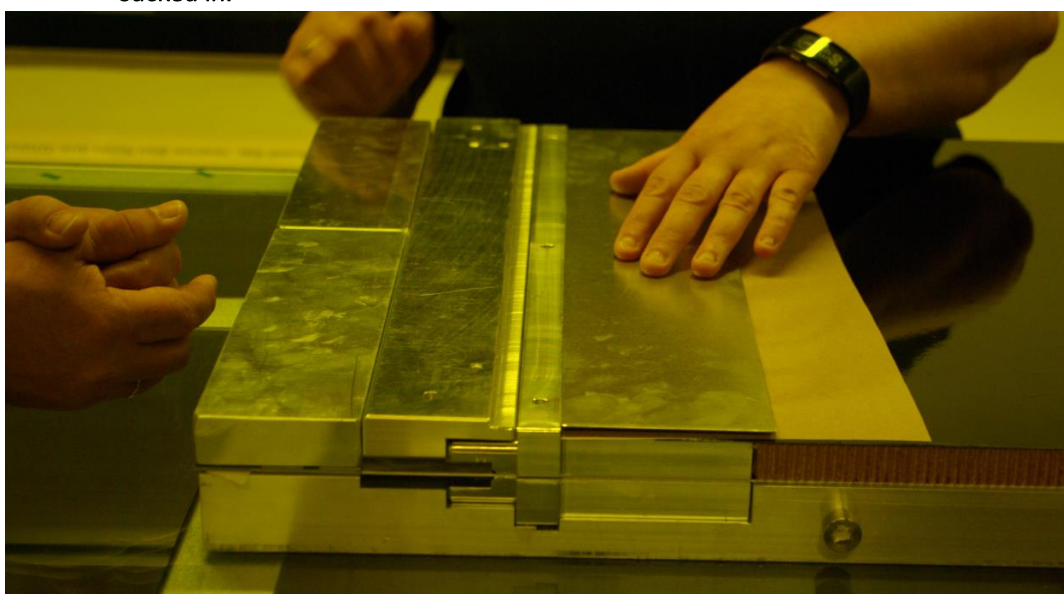

Figure 48 Silicon paper and aluminum sheet at endplug

- 5.1.4.15 *Place the rubber sheets 530 mm x 300 mm x 2 mm over the endplug region, this limits the stress on the vacuum hood due to edges (without figure).*
- 5.1.4.16 *Place vacuum hood over the jig, connect vacuum pump "Busch Samos 0200" to the hood and apply 0.15 +/- 0.025 bar vacuum. Let the glue cure 24 hours while applying vacuum.*

5.2 2ND GLUING STEP

The gluing of the second step takes approximately 75 minutes and needs two technician, a third person is needed for assistance.

5.2.1 Parts

- 1 x Panel "HE_LHCB_SCIFI_PAN_908411_A_0__LHCb-SciFi-Verbundplatte-top"

5.2.2 Equipment

- 1 Gluing and Alignment Jig „HE_LHCB_SCIFI_VOR_GJ_906400_A_0__KLEBE_u._AUSRICHTVORRICHTUNG-PANEL“
- 2 x Bridge „HE_LHCB_SCIFI_VOR_GJ_006402_P_0__BRUECKE_ENDPLUG“
- 1 x Bridge „HE_LHCB_SCIFI_VOR_GJ_006403_P_0__BRUECKE_MITTE“
- 12 x Eccenter „HE_LHCB_SCIFI_VOR_GJ_006404_P_0__Exzenter“
- 12 x Bracket „HE_LHCB_SCIFI_VOR_GJ_006406_P_0__Anschlag“
- Dowel pins 8 x Ø6x30
- 1 Vacuum hood
- 1 Vacuum pump "Leybold DIVAC 2.2 L"
- 1 Vacuum pump "Busch Samos 0200"
- 1 Lifting and Turning device
- 6 x M8x40 screws
- Sealer agent Mikon 199 / Release agent Mikon 205
- Araldit AW116 (mix 800gr, 750gr is used per gluing step)
- 1 set glue applicator
- 1 set foam Roller (apply glue on Endplugs)
- 1 toothed spatula (apply glue on mats)
- 1 roll Silicone paper
- 2 x rubber sheet 530 mm x 300 mm x 2 mm
- 1 x Security belt

5.2.3 Production description

5.2.3.1 *Remove the vacuum hood*

5.2.3.2 *Remove the bridges "HE_LHCB_SCIFI_VOR_GJ_008201_D_0__ABSTECKVORRICHTUNG-EPiece-EPlug" and the dowel pins Ø6x20/M3 and Ø6x13/M3*

5.2.3.3 *Place the "Lifting and Turning device" over the half module on the jig.*

5.2.3.4 *Align the "Lifting and Turning device" to the endplugs and fix the device to the endplugs with 6 M8x40 screws.*

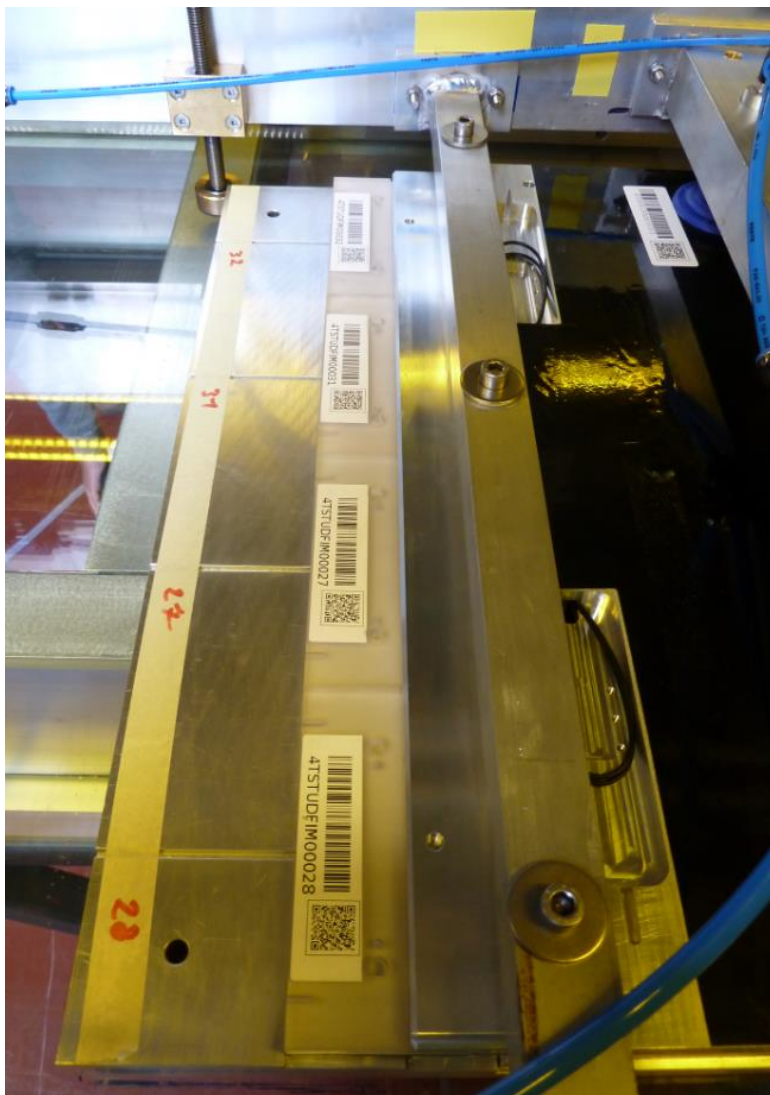

Figure 49 "Lifting and Turning device" aligned and fixed to the endplug

5.2.3.5 Lift carefully the module out of the jig by taking care to lift it horizontally avoiding the half module to cant.

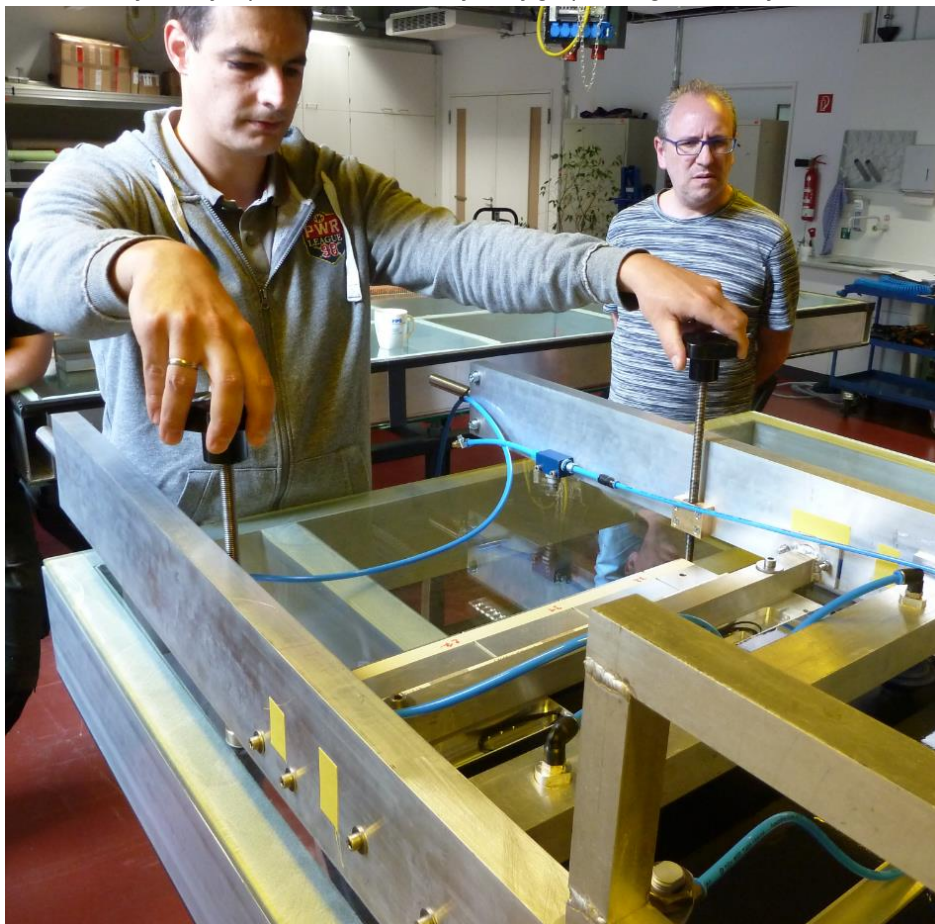

Figure 50 Lifting carefully the half module

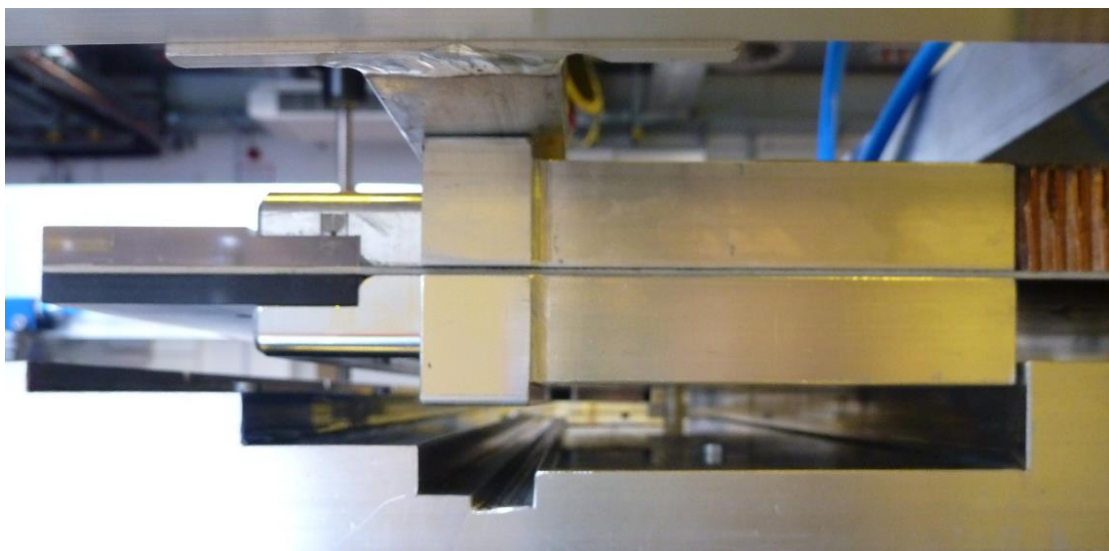

Figure 51 Endplug lifted from gluing jig



Figure 52 Mats lifted from gluing jig

5.2.3.6 Lift the half module approximately 30 mm over the jig.

5.2.3.7 Place the “security belt” in the middle on the module and attach it to the “Lifting and Turning device”.



Figure 53 “Security belt”



Figure 54 “Security belt” attached to the “Lifting and Turning device”.

5.2.3.8 Remove the half module from the jig, turn it and place the “Lifting and Turning device” on the extractable bars on the side of the gluing table.

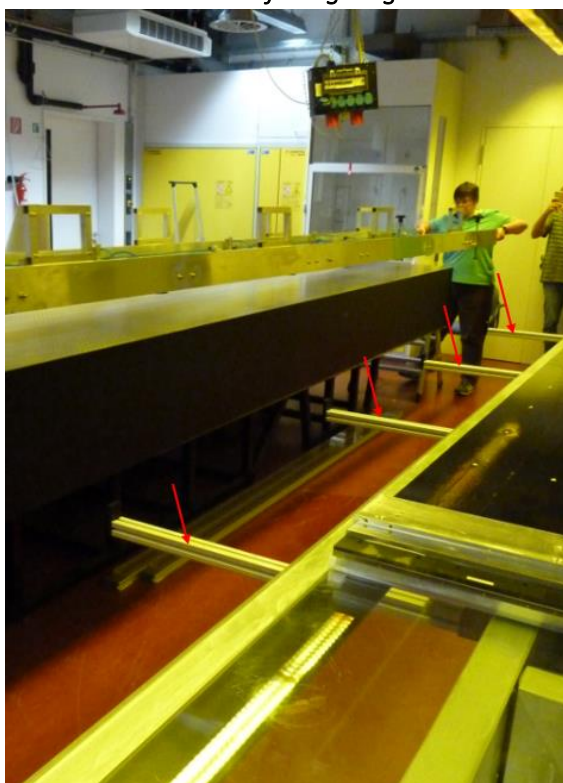

Figure 55 Gluing table with extractable bars

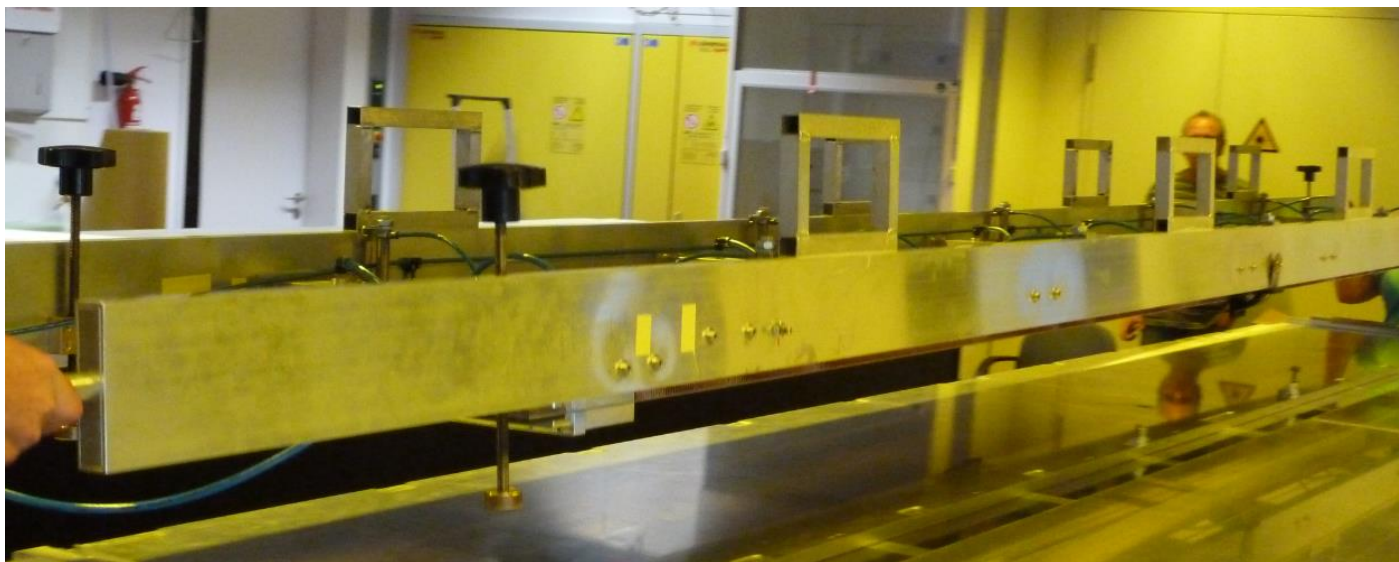

Figure 56 Removal of the half module from jig

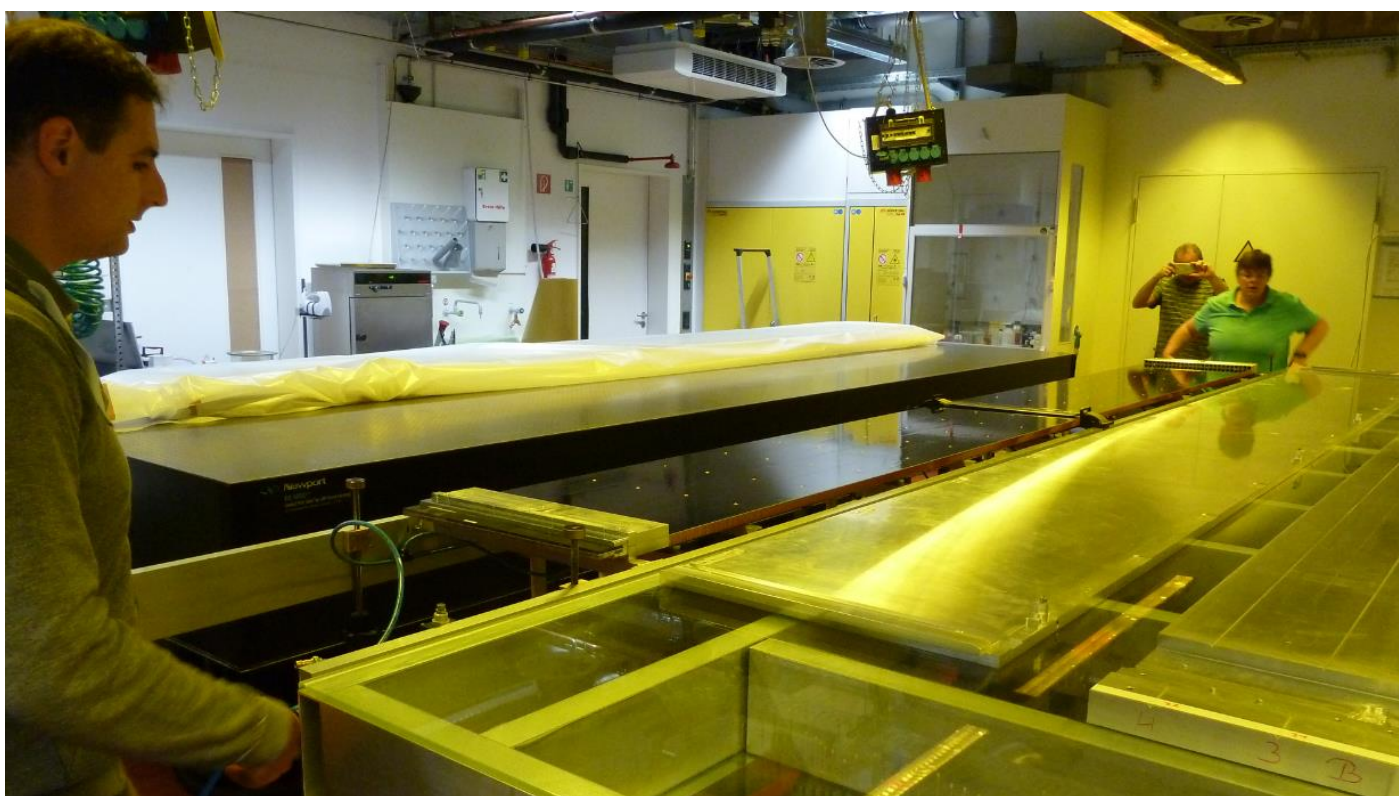

Figure 57 "Lifting and Turning device" with half module turned and placed next to the gluing table

- 5.2.3.9 Remove the “security belt” and the screws fixing the endplugs to the “Lifting and Turning device”
- 5.2.3.10 Apply pressurized air to the “Lifting and Turning device” to lift up the half module of the suction cups so that it’s lying on the sliding rails.
- 5.2.3.11 Align the module to the gluing jig
„HE_LHCb_SCIFI_VOR_GJ_906400_A_0_KLEBE_u._AUSRICHTVORRICHTUNG-PANEL“.
- 5.2.3.12 Push the module carefully on the gluing jig.



Figure 58 Half module been pushed on the gluing jig

- 5.2.3.13 Place the bridges “HE_LHCb_SCIFI_VOR_GJ_006402_P_0_BRUECKE_ENDPLUG” at the endplugs position and the bridge “HE_LHCb_SCIFI_VOR_GJ_006403_D_0_BRUECKE_MITTE” at the endpieces mirror side position.
- 5.2.3.14 Align the half module to the bridges with the 8 dowel pins $\varnothing 6 \times 30$. Block position with eccentric device.

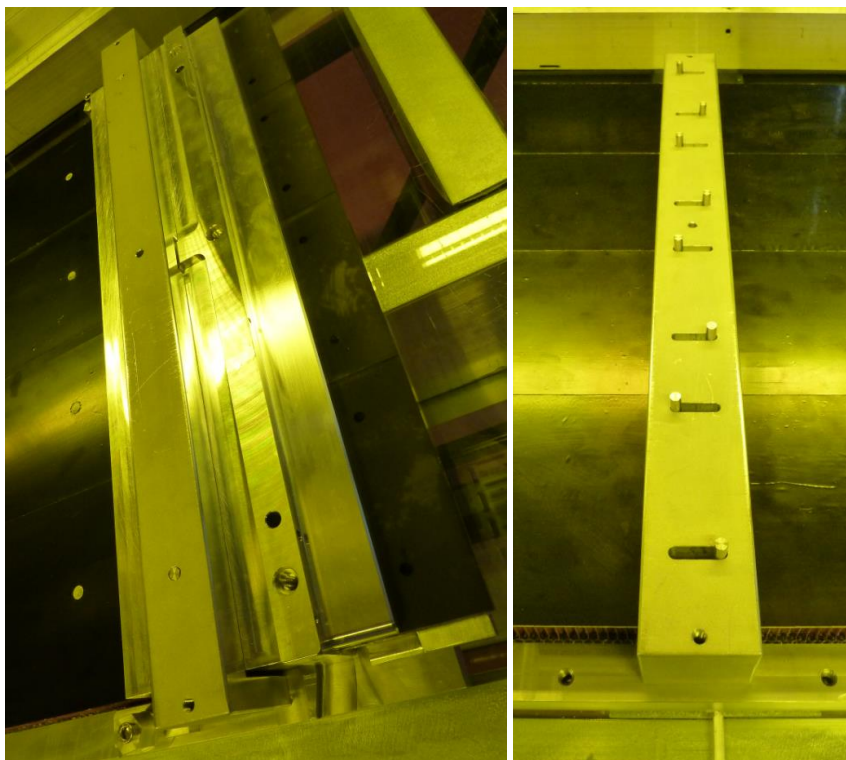

Figure 59 Bridge placed on endplug and on endpieces mirror side and aligned with dowel pins

5.2.3.15 Block the position of the half module with eccentric device (“HE_LHCB_SCIFI_VOR_GJ_006404_P_0__Exzenter” and “HE_LHCB_SCIFI_VOR_GJ_006406_P_0__Anschlag”) distributed over the whole module length on both sides.

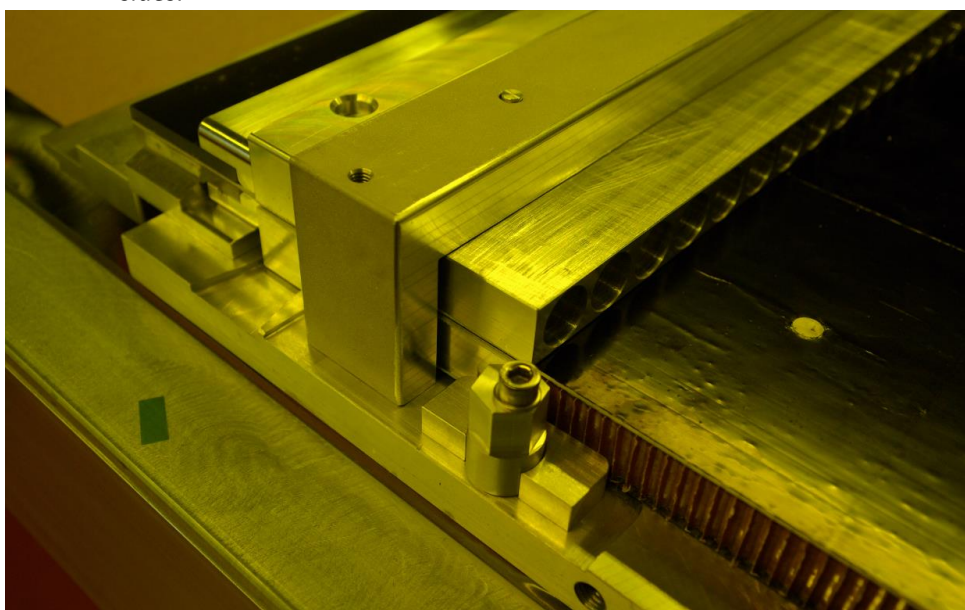

Figure 60 Eccentric device blocking the position of the module

5.2.3.16 Once the position blocked, remove the dowel pins and the bridges

5.2.3.17 Prepare 800 g of glue Araldit 116.

5.2.3.18 One person can apply the glue (Glue Araldit 116) over all mats at once with the glue applicator in sinuous lines while the second follows by spreading the glue with the toothed spatula.

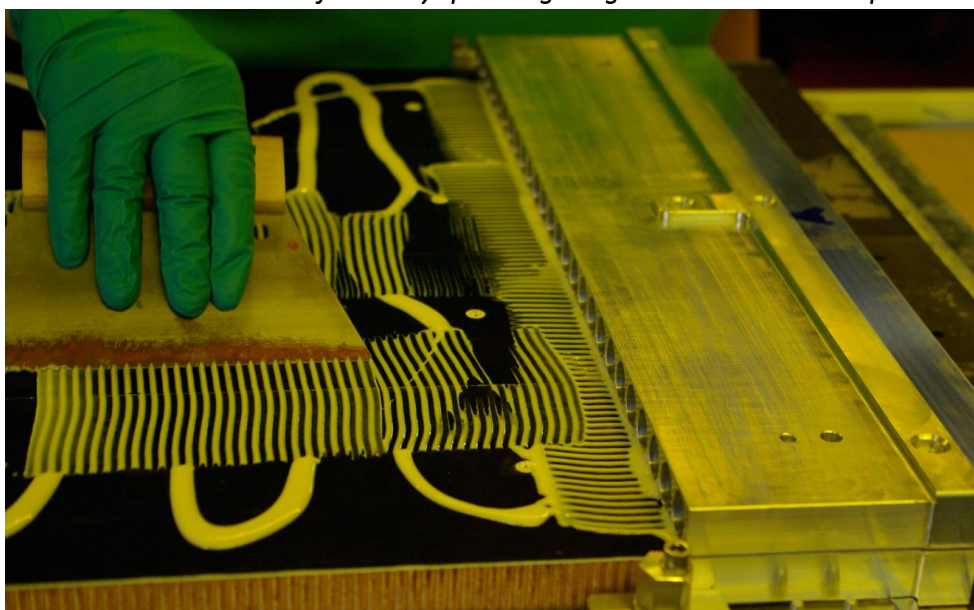

Figure 61 Sinuous lines of glue spread over all mats with the toothed spatula

5.2.3.19 Repeat steps from 5.1.4.10 to 5.1.4.16 of the Production description of the 1st gluing step. Step 5.1.4.14 is not needed here.

5.3 MOUNTING OF THE COLD-BOX FLANGES

The mounting of the cold-box flanges takes approximately 30 minutes and needs one technician.

5.3.1 Parts

- 2 x Cold-box flange "HE_LHCb_SCIFI_PAN_008600_P_0__COLDBOX-FLANGE"
- 16 x Screws ISO 4762 - M3x14
- 4 x Dowel pins ISO 8734 - 5x14 - A -St

5.3.2 Equipment

- 1 Gluing and Alignment Jig „HE_LHCb_SCIFI_VOR_GJ_906400_A_0__KLEBE_u._AUSRICHTVORRICHTUNG-PANEL“
- Light tight silicon

5.3.3 Production description

5.3.3.1 Apply a line of light tight silicon to the inner edge of the sealing surface of the cold box flange all around the endplugs.

5.3.3.2 Fill with light tight silicon the gap between the two neighboring endplugs.

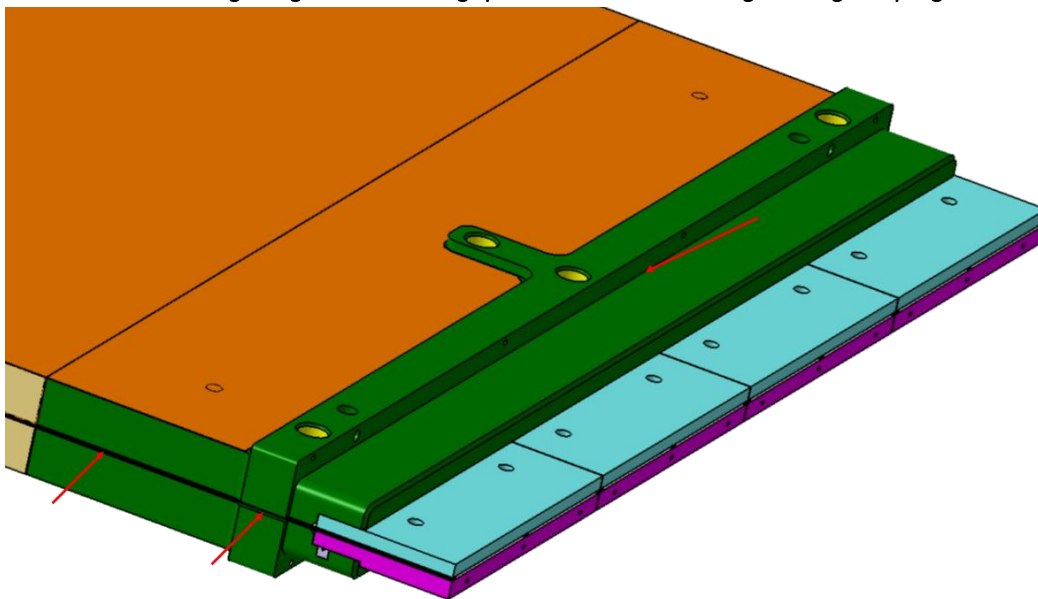

Figure 62 Inner edge of the sealing surface cold-box and gap between neighboring endplugs

5.3.3.3 Place the dowel pins ISO 8734 - 5x14 - A -St in the endplugs.

5.3.3.4 Place the cold-box on the endplug.

5.3.3.5 Screw it tight with the screws ISO 4762 - M3x14.

5.3.3.6 Remove any excess silicon that comes out. All surfaces should be flat and smooth.

5.4 GLUING OF SIDE PROFILES

The gluing of the side profiles takes approximately 45 minutes and needs two technicians. This step should be done right after the Mounting of the cold-box flanges.

5.4.1 Parts

- 4 x Side wall profiles "HE_LHCB_SCIFI_PAN_908412_A_0__U-SHAPE"
- Equipment
- 1 Gluing and Alignment Jig „HE_LHCB_SCIFI_VOR_GJ_906400_A_0__KLEBE_u._AUSRICHTVORRICHTUNG-PANEL
- 1 Vacuum pump "Leybold DIVAC 2.2 L"
- 1 Lifting and Turning device
- Araldit AW116 (50 g)
- Syringe
- PET-tape
- PVC sheet as distance holder (thickness 4mm)

5.4.2 Production description

5.4.2.1 *Place the module on the PVC sheet with the endplugs “HE_LHCb_SCIFI_PA N_008034_P_1__EndPlug-top” facing up. (PVC sheet compensate the thickness of the cold-box flange collar)*

5.4.2.2 *Place the side walls on the module.*

5.4.2.3 *Apply the glue Araldit AW116 between polyimide surface of the panel and the side wall profiles over the whole length of the module. The second technician ensures that the side walls stay in place during the operation.*



Figure 63 Applying glue between side walls and polyimide surface of panels

5.4.2.4 *Fix the side walls to the polyimide surface with PET-tape to avoid the glue spreading out.*



Figure 64 PET-tape to avoid the glue spreading out

5.4.2.5 *Lift carefully the module with the “Lifting and Turning device”.*

5.4.2.6 *Place the “security belt” in the middle on the module and attach it to the “Lifting and Turning device”.*

5.4.2.7 *Lift and turn the module and place the “Lifting and Turning device” on the extractable bars on the side of the gluing table.*

5.4.2.8 *Align the module to the gluing jig
„HE_LHCb_SCIFI_VOR_GJ_906400_A_0_KLEBE_u._AUSRICHTVORRICHTUNG-PANEL“*

5.4.2.9 *Push the module carefully on the gluing jig.*

5.4.2.10 *Repeat step from 5.4.2.3? And 5.4.2.4?*

5.4.2.11 *Control by eye the proper fitting of the side walls and correct it if necessary. Place the ledges on the sides of the jig for the width constraints of the whole module (under development).*

5.4.2.12 *Place the rubber sheets 530 mm x 300 mm x 2 mm over the endplug region, this limits the stress on the vacuum hood due to edges (without figure).*

5.4.2.13 *Place vacuum hood over the jig, connect vacuum pump “Busch Samos 0200” to the hood and apply 0.15 +/- 0.025 bar vacuum. Let the glue cure 24 hours while applying vacuum.*

6 APPENDIX

6.1 DATA SHEETS

6.2 SAFETY SHEETS

6.3 DRAWINGS

Files corresponding to 7.1, 7.2 and 7.3 can be found in the attached zip file.