



PHYSIKALISCHES
INSTITUT



B. Leverington, A. Anjam, T. Herold, S. Hummel, T.
Mittelstaedt, S. Bachmann, U. Uwer, B. Windelband

MODULES & PRODUCTION (A GENERAL OVERVIEW)

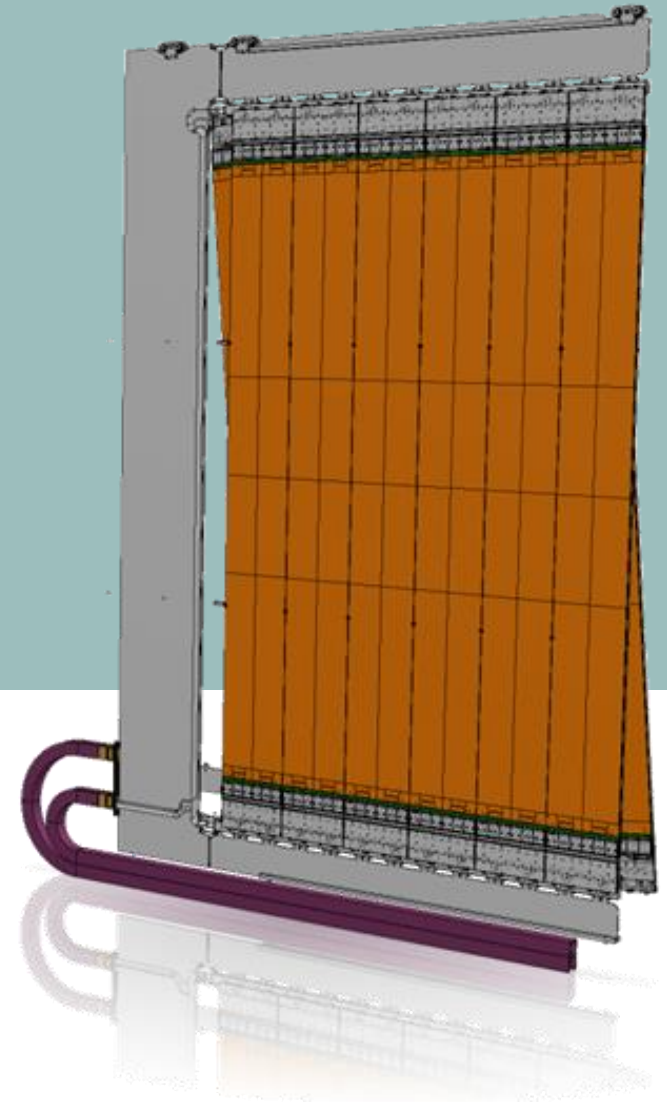

OUTLINE

Module overview

- Physics motivations (EDR design reminder) and Requirements
- Description of a module
- Interfaces
- Beam-pipe modules

Part Production

- Light Injection System
- Endplugs
- Cold-box Flange
- Longitudinal cuts of the fibre mats
- Panels
- Sidewalls (U-profiles)

Module Production

- Mat and panel gluing
- Sidewall and flange gluing
- Estimates schedule and acceptance requirements

Storage

MODULE OVERVIEW

MODULE REQUIREMENTS

- The detection efficiency for single hits or clusters of hits should be close to 99%.
- The single hit spatial resolution in the bending plane of the magnet (x direction) must be better than 100 micron.
- The construction principle of the mats and modules assumes that the fibres inside a single module (8 mats) are straight and aligned better than 0.050 mm in the x-direction, and the fibre layers are within 0.300 mm in the z-direction.
- Time variations of the module positions and the module shape should be avoided.
- About 1% of a radiation length per detection layer
- Survive 50fb^{-1} of radiation (35 kGy near the beam pipe)

ASSEMBLY PARTS

8 finished fibre mats

4 endplugs of 2 types

- Light injection
- Mounting

2 Honeycomb/CFRP Half-panels

2 CFRP sidewalls

2 Cold-box flanges

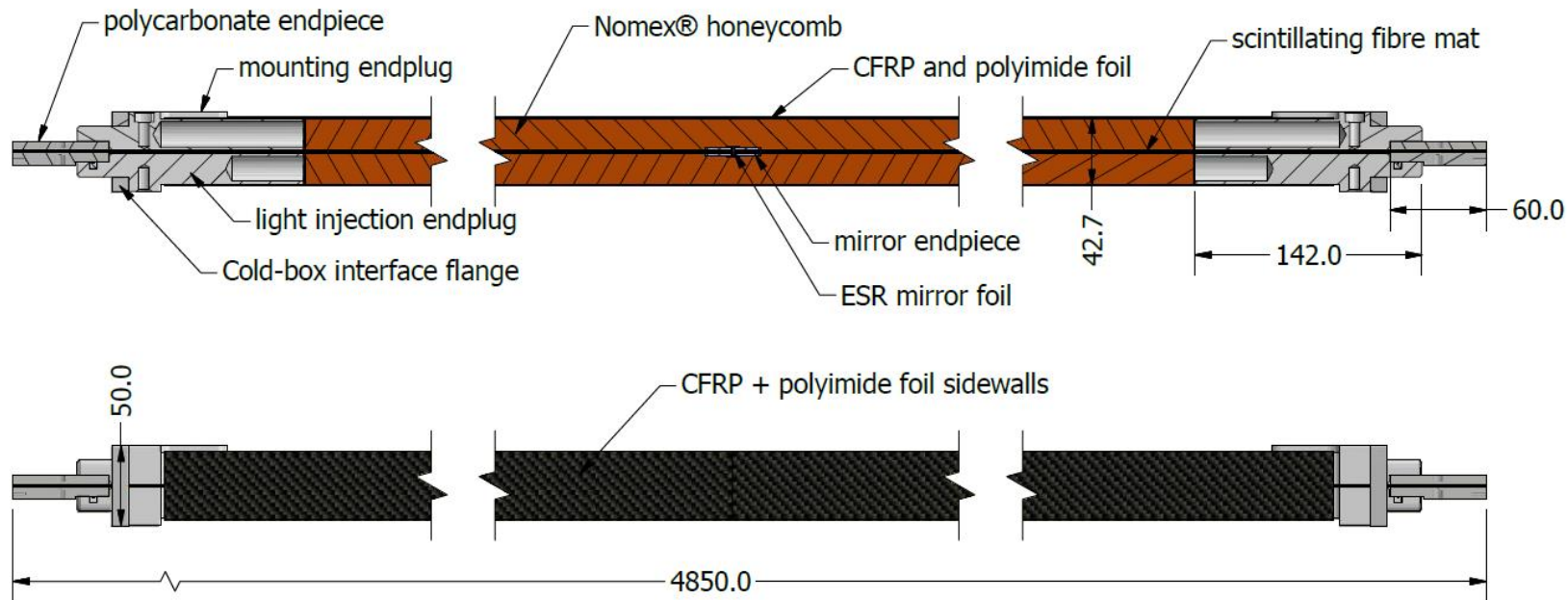

MODULE OVERVIEW

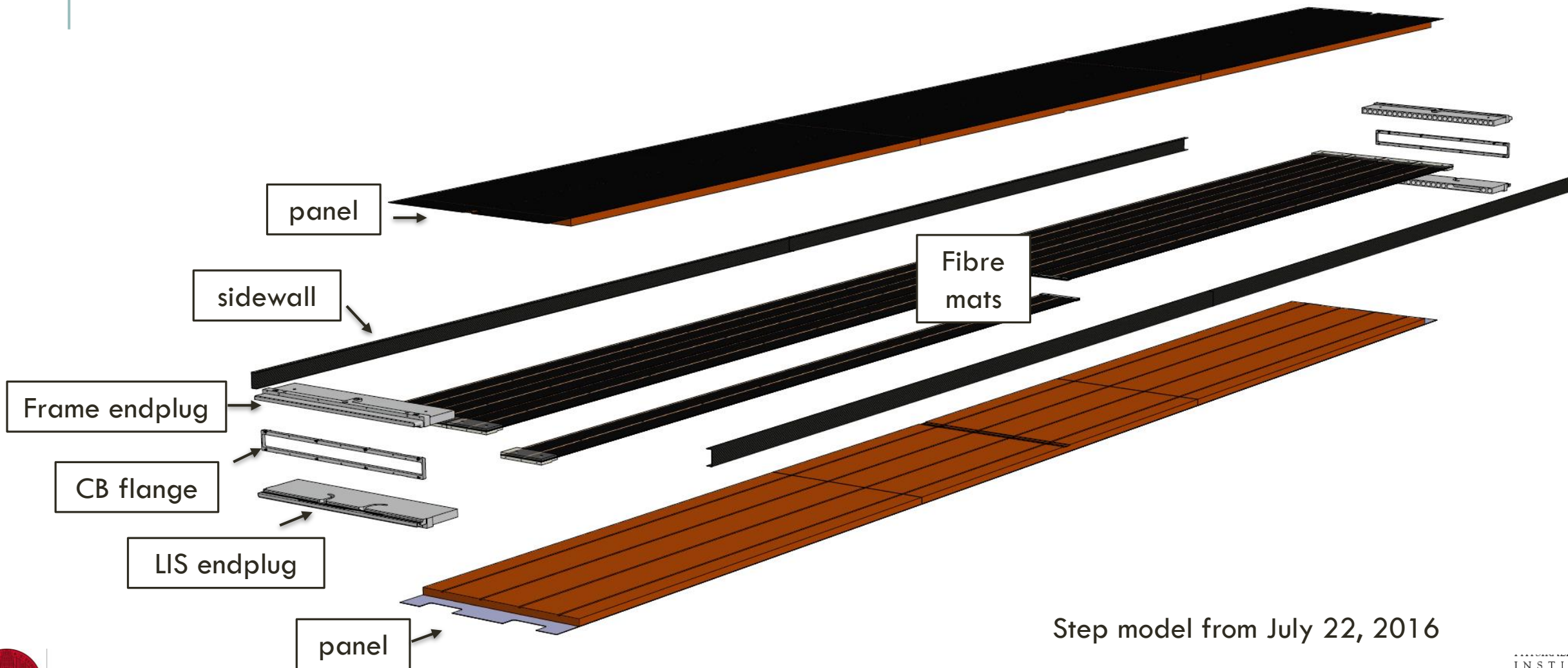

Step model from July 22, 2016

CHANGES SINCE THE EDR (JUNE 2015)

Foil laminated mats instead of glue cast

vacuum lifting jig for template removal

2nd template with bridges for second alignment

CFRP Sidewalls

Foils on the panels for light tightness

Modified endplug designs (LIS and frame)

8 MATS : STRAIGHT WITH MINIMAL GAPS

Pin
distan
ce

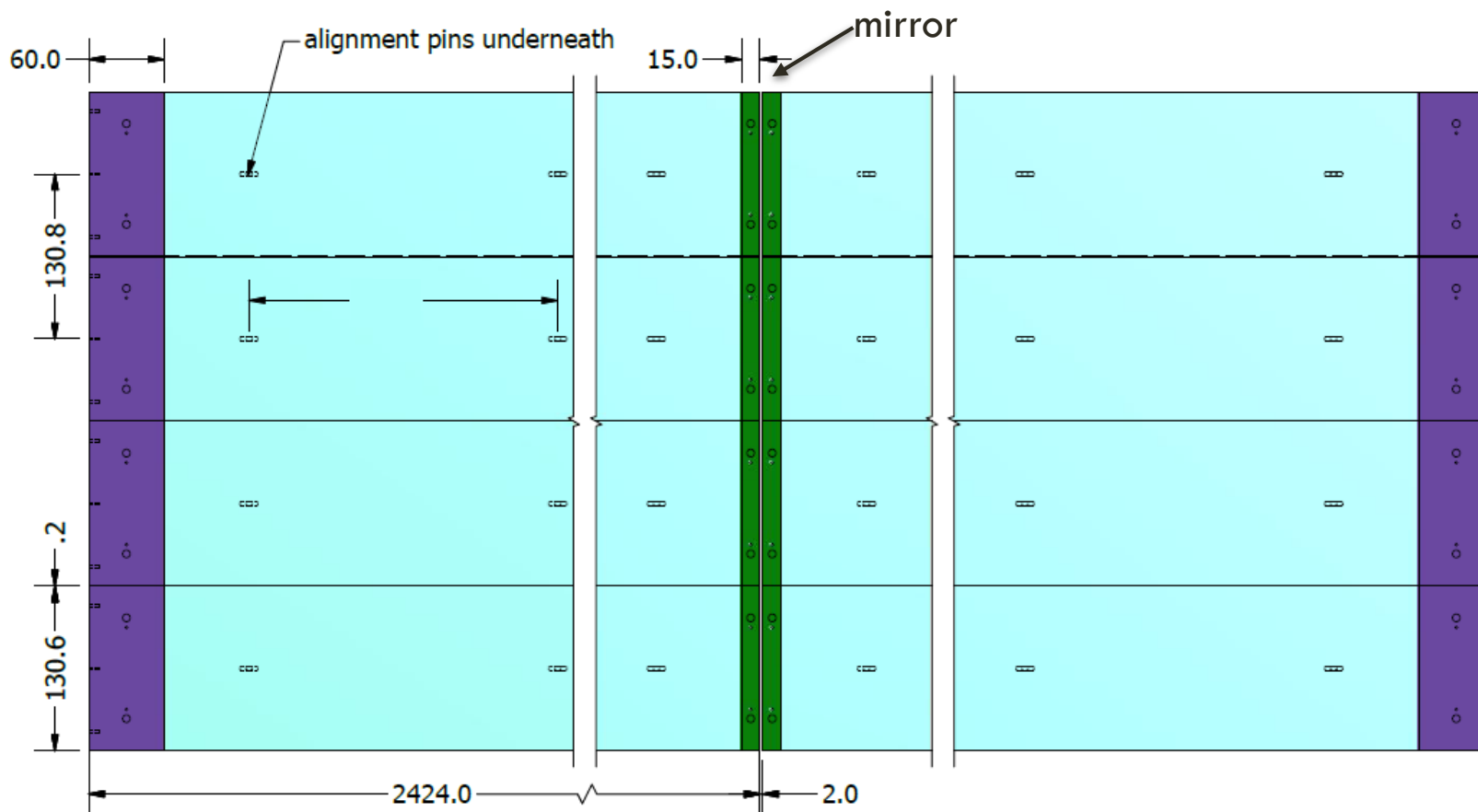

SUPPLY CHAIN

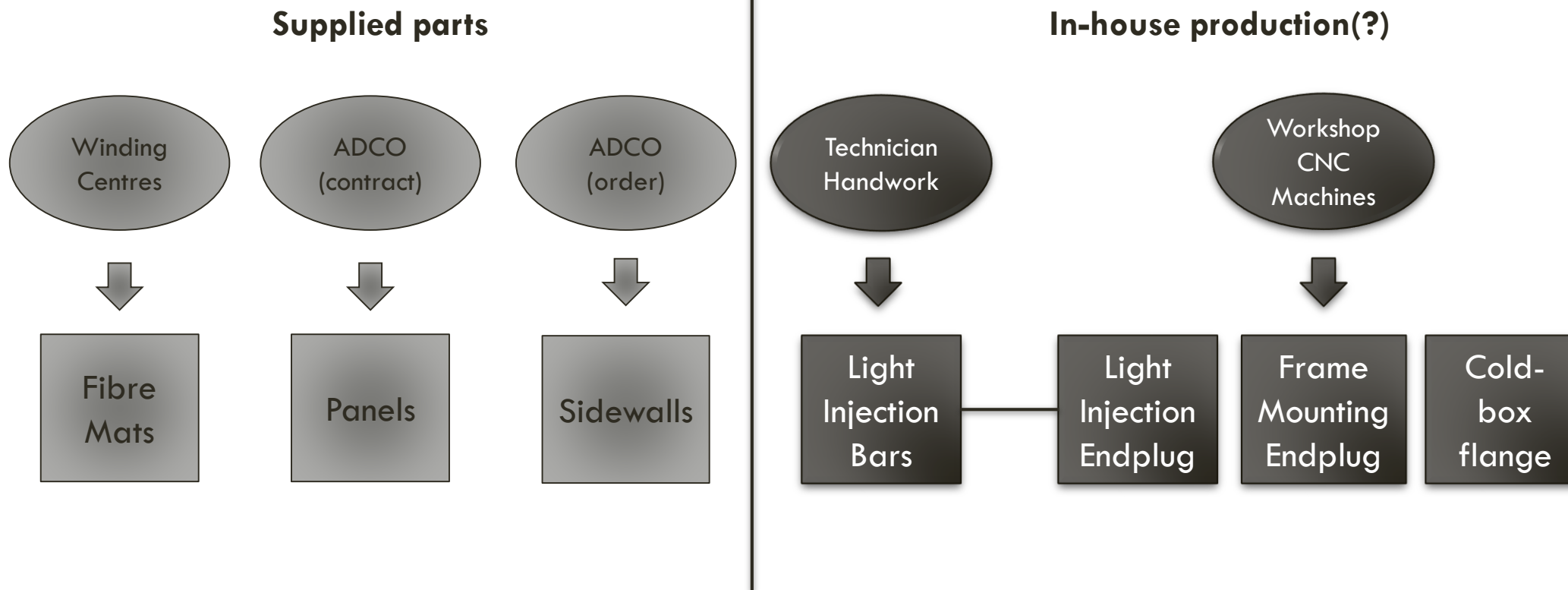

WORK FLOW

Part Production, Receiving and Storage

Panels, endplugs, fibre mats,
flanges, sidewalls

Fibre mats:
Longitudinal cuts

Light bar
production

Endplug
preparation

Module Production (bonding all the parts)

Module QA

Module Storage, Monitoring and Transport



SOME MORE NUMBERS

Fibre width = 522.85 mm

Panel width = 525.0 mm

Distance between module centres = 529.0 mm

- Driven by the cold-box width

2mm for sidewalls and tolerances on each side

$$\text{Final module width} = 1 + 525 + 1 = 527 \text{ } +0/-1 \text{ mm}$$

MATERIAL BUDGET

Material	Thickness (micron)	Layers	X0 (cm)	%X0	kg/m ³	mass (kg)	%mass
Fibres + glue(TiO ₂)	1350	1	33.2	0.407	1180	4.10	0.20
Nomex Core	19700	2	1300	0.303	32	3.03	0.15
CF skin	200	2	27.56	0.145	1540	1.53	0.08
Araldite Glue	260	2	36.1	0.144	1160	1.50	0.07
Black Kapton Foil	25	4	35	0.029	1410	0.36	0.02
Polycarbonate	10000	2	N/A	N/A	1200	1.78	0.09
Alu Endplugs	19700	2	N/A	N/A	2700	8.00	0.39
Sidewalls	200	2	27.56	0.145	1540	0.30	0.02

Total %X0 = 1.03% (1.18% at sidewalls)

Total Mass = 20.6 kg (plus CB flanges)

EDR = 1.02% with
glue casting

MODULE INTERFACES

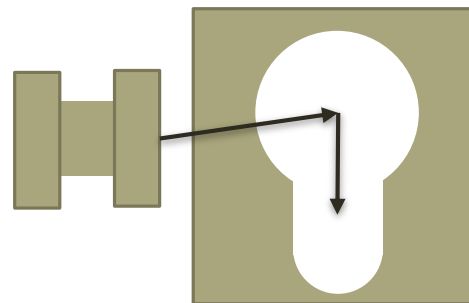

Hook and Keyhole concept

Frame

The module hangs on three pins on both ends.

On the top side, the mounting the has following functions:

- Center pin – Support module weight and defined position in X and Y axes
- Side pins – Block the Z-axis(twists)

On the bottom side

- Center pin – Guides the module along the Y-axis
- Side pins – Block the Z-axis (twists)

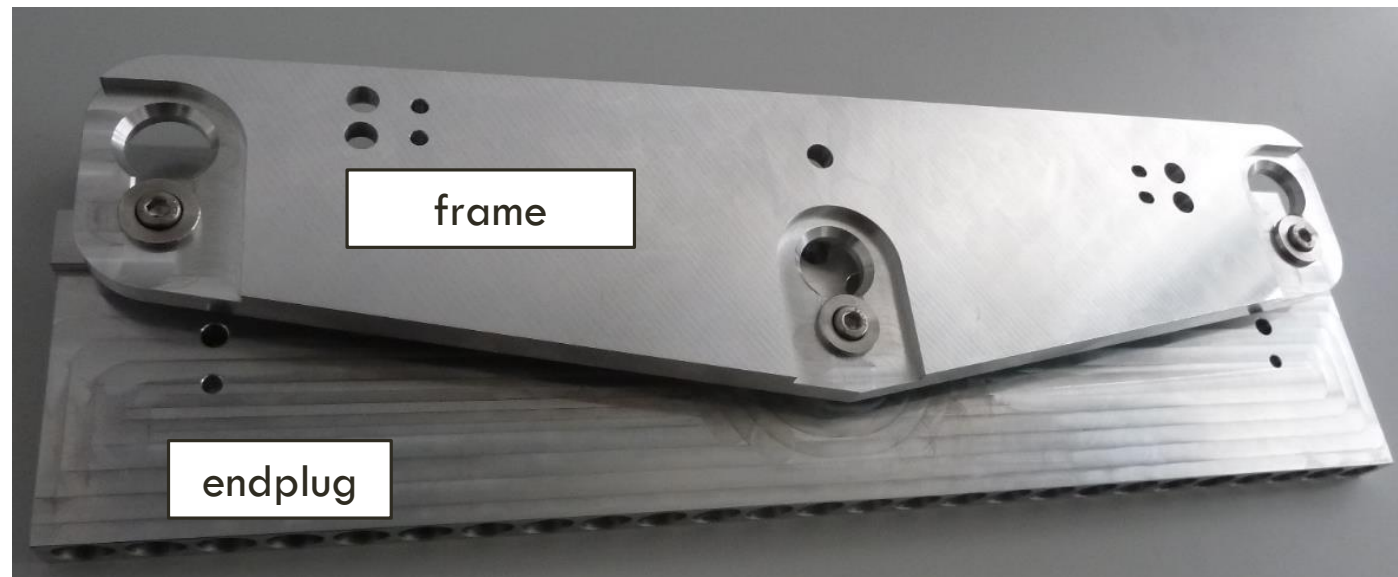

“Hooks” are threaded into precision holes in the module endplugs. Can be modified at a later date.

Off-centre alignment of the hooks over constrains the endplug, defining the vertical plane by the frame.

MODULE INTERFACES

Cold-box

Tolerances and design discussed with Nikhef

Issues:

- Sealing for light tightness and humidity
- Alignment (variable sandwich thickness)
- Tolerances on sandwich thickness (few tenths mm)

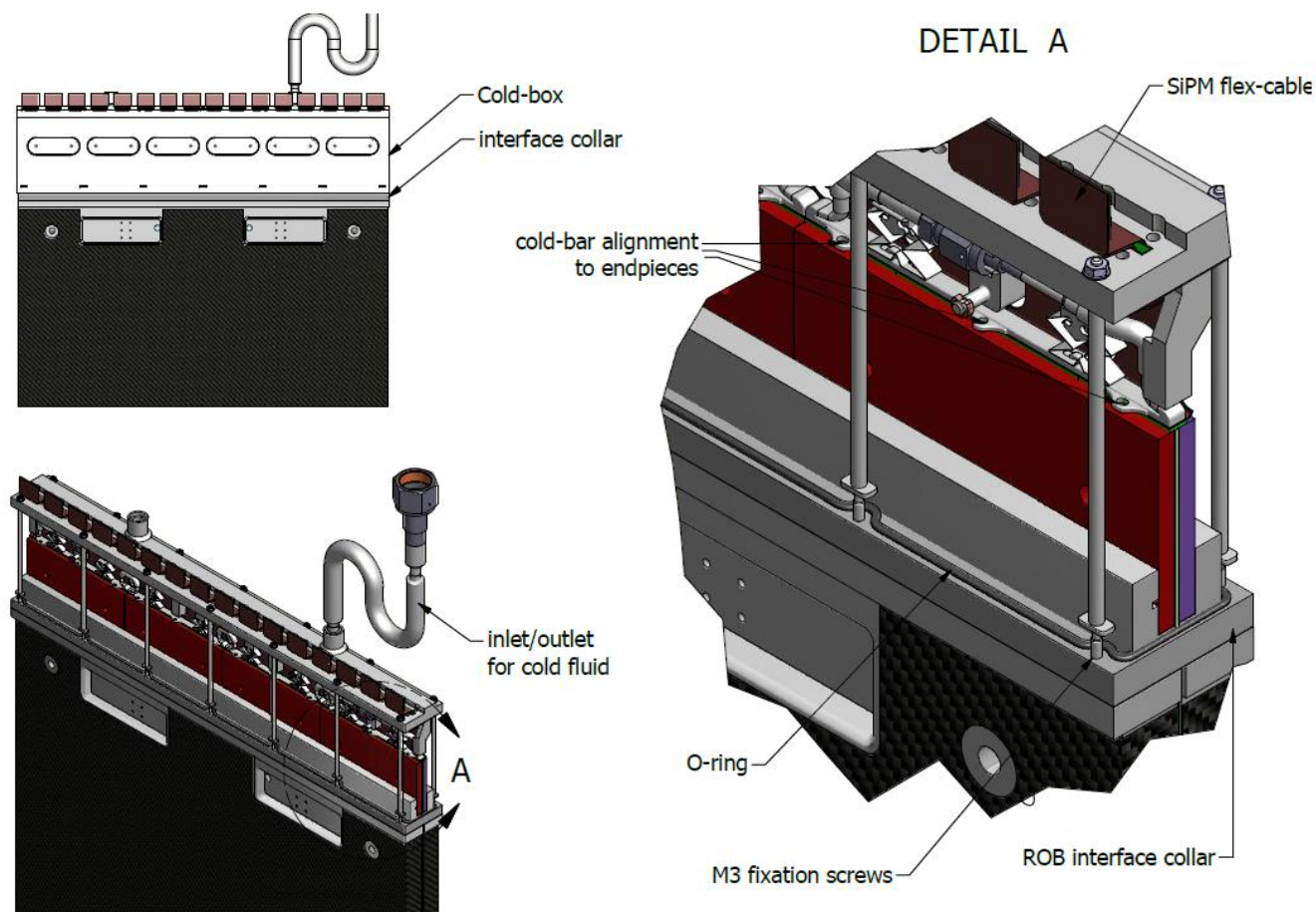
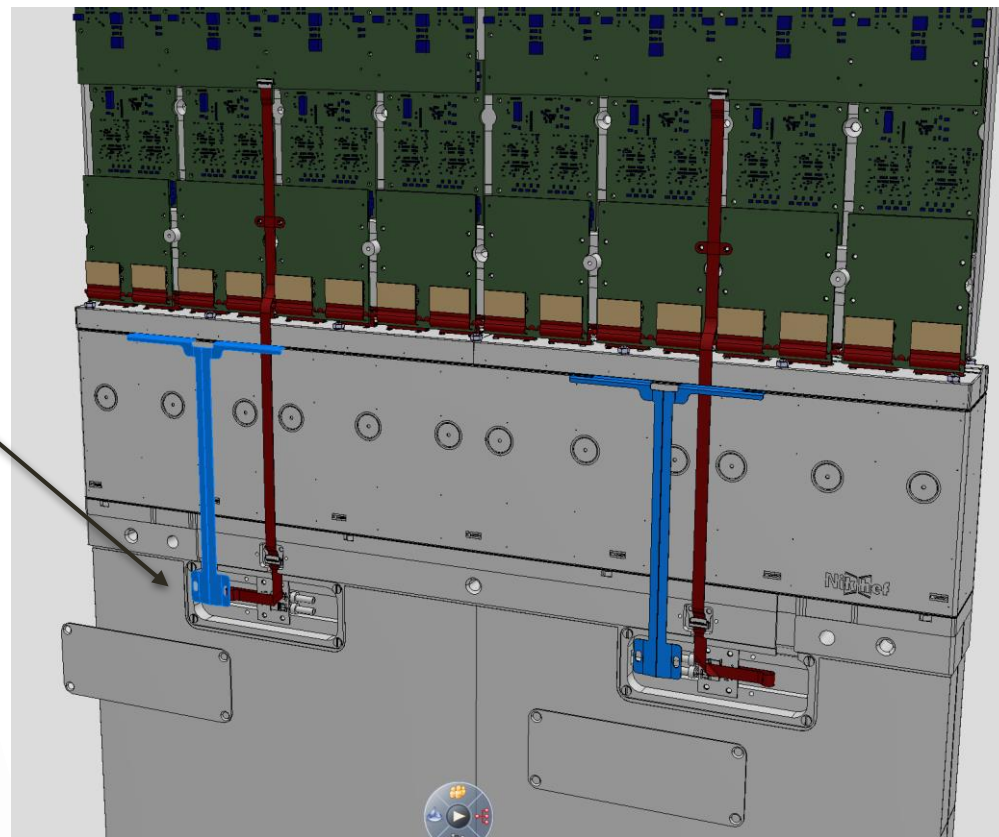
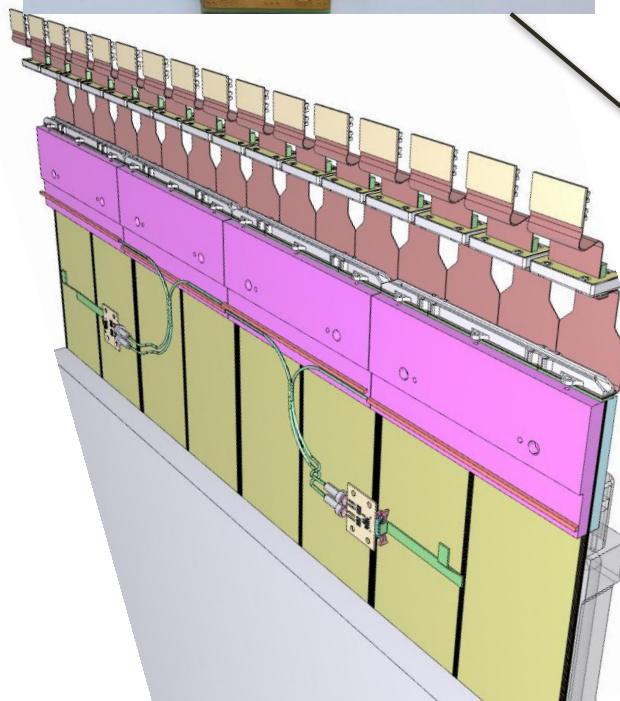
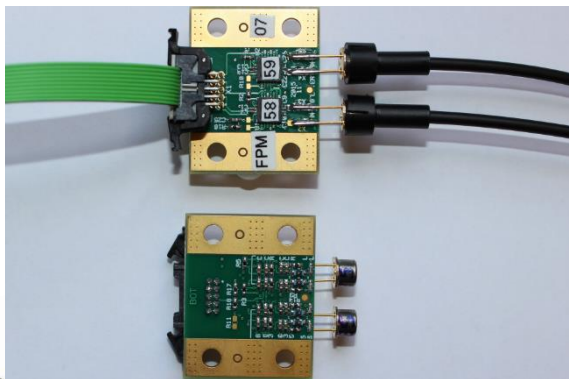

Figure 5.1: The Read-out Box (ROB) attached to the module (only the cold part of the box is shown). The interface collar is shown between the ROB and module. The alignment holes aligning the cold-bar to the endpieces is also indicated.

LIGHT INJECTION SYSTEM

Laser (VCSEL) system
embedded in the endplugs for
calibration of the SiPMs

Signal cable from the FE
electronics over the cold-box



BEAM PIPE MODULES

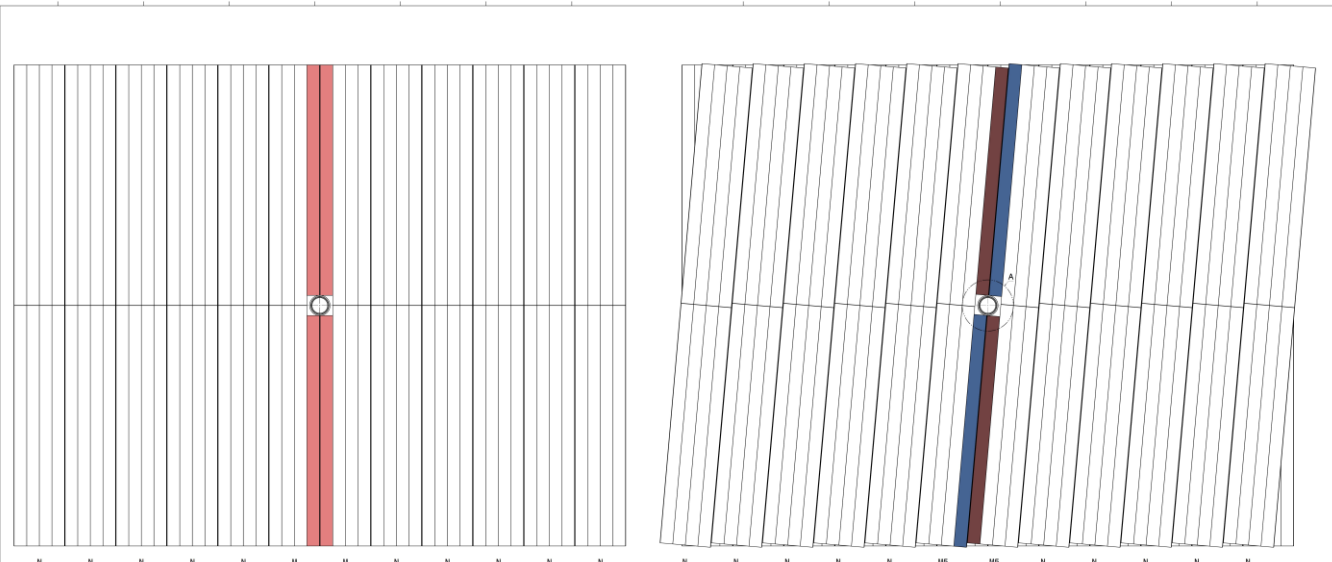

2 types: BP-X and BP-UV

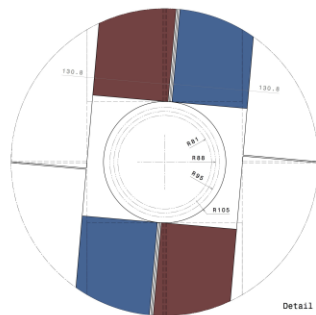

Detail A

Project: LHC Upgrade SCIFI	Author: [Name]
Part: Assy M-N-MS-A11	Checked: [Name]
Scale: 1:1	Date: 2016-07-28
Material: [Material]	Revision: 1

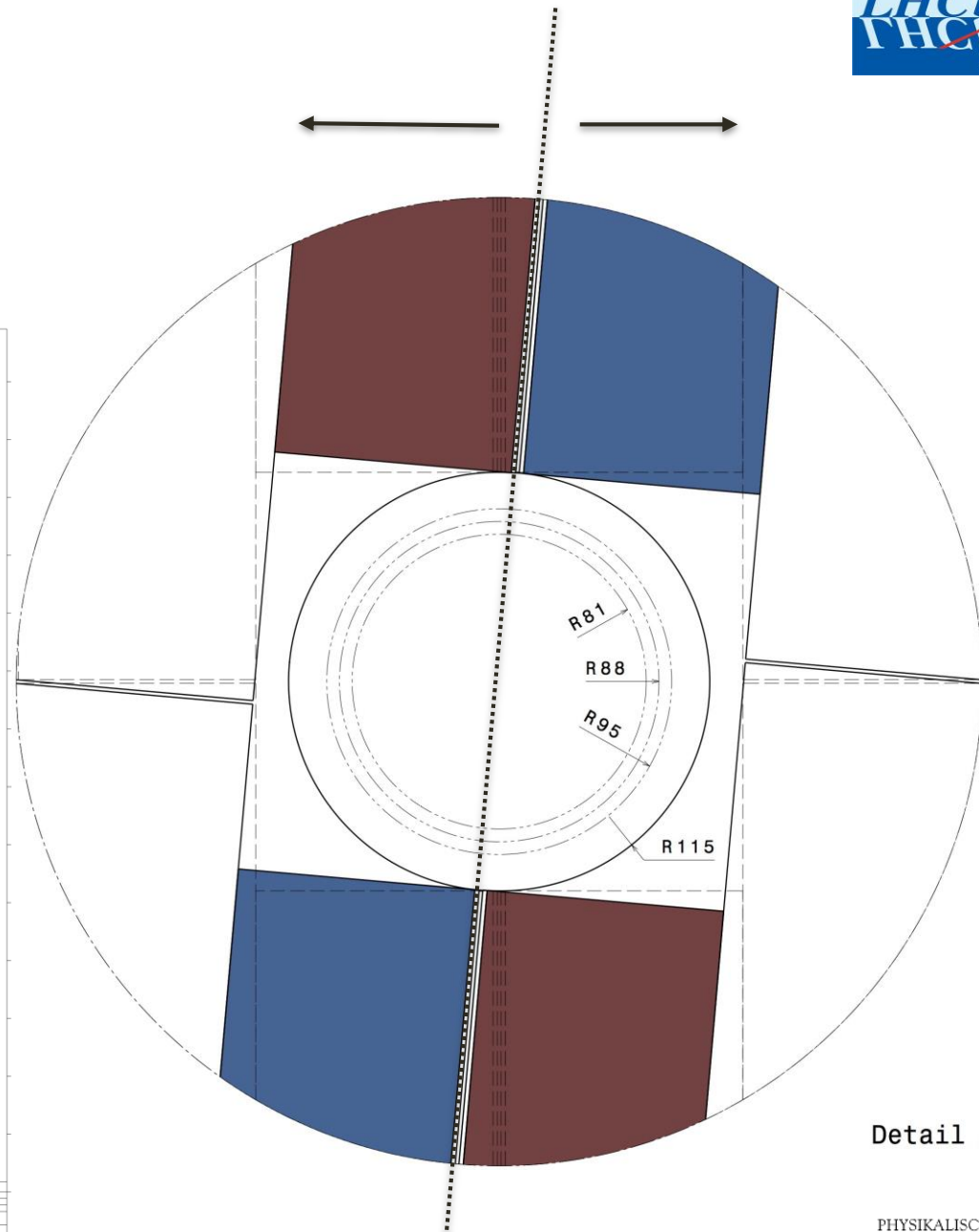

Detail ,



BEAM PIPE MODULE TOOLS



X-type
modules

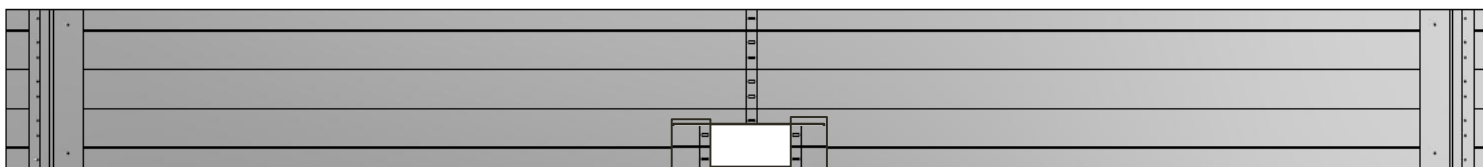

BPX-type
modules

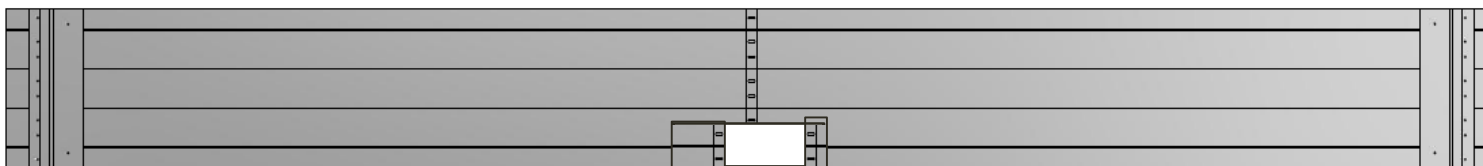

BPUV-type
modules

A new common template will be produced for all 3 types of modules using changeable inserts (one for HD, one for Nikhef)

SPARE MODULES

1 spare for every beam pipe module
(most damaged by radiation)

= 24

10% normal module spares

= 10

128 + 24 + 10

= 162 total modules to be produced

Requires 1296 fibre mats of good
quality

(96 mats of special length for beam
hole)

MODULE PRODUCTION SCHEDULE

Last fibre from Kuraray
January 22, 2018

Begin serial module
production in
October/November 2016

Last Modules produced in
the end of March 2018
(hopefully)

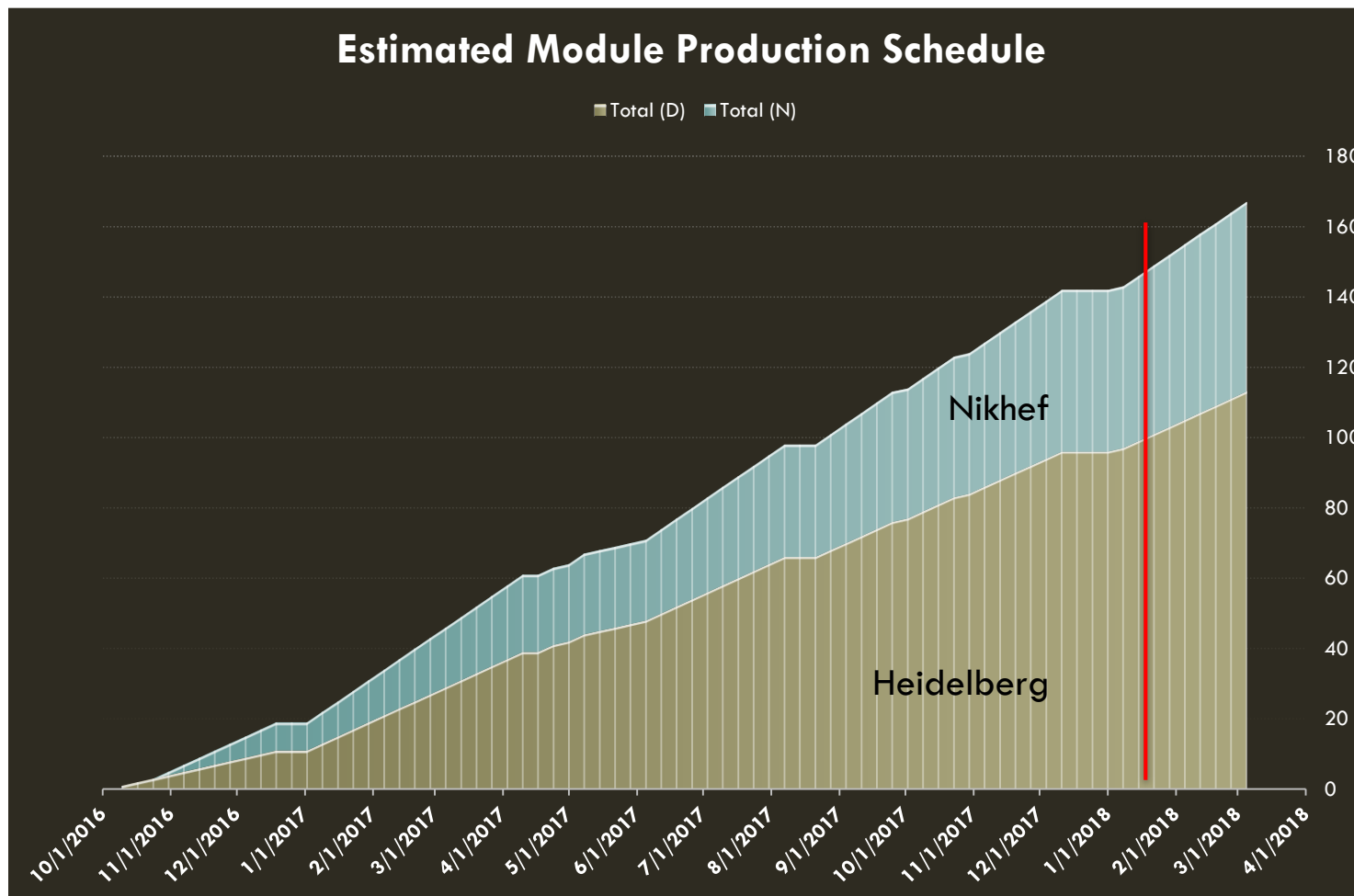

ACCEPTANCE CRITERIA

Geometrical tolerances

- Modules must fit with neighbouring modules ($527 \pm 0\text{mm} / -1\text{mm}$)
- Cold-box / SiPMs must fit and align to the fibre mats
 - check end of the module with a coldbox dummy.

No light leaks.

Light output of finished module measured with cosmics

- No degradation compared to fibre mat tests (damaged mirrors, broken fibres, etc.)

PART PRODUCTION

PANELS

Description

- 32kg/m³ nomex honeycomb
- 0.2mm CFRP skins
- 25 micron black polyimide foil

- Contract with ADCO for production and delivery

QA

- Check overall dimension
- Check cut-outs for pins/LIS/Mounting
- Check quality of gluing of the light tight polyimide foil

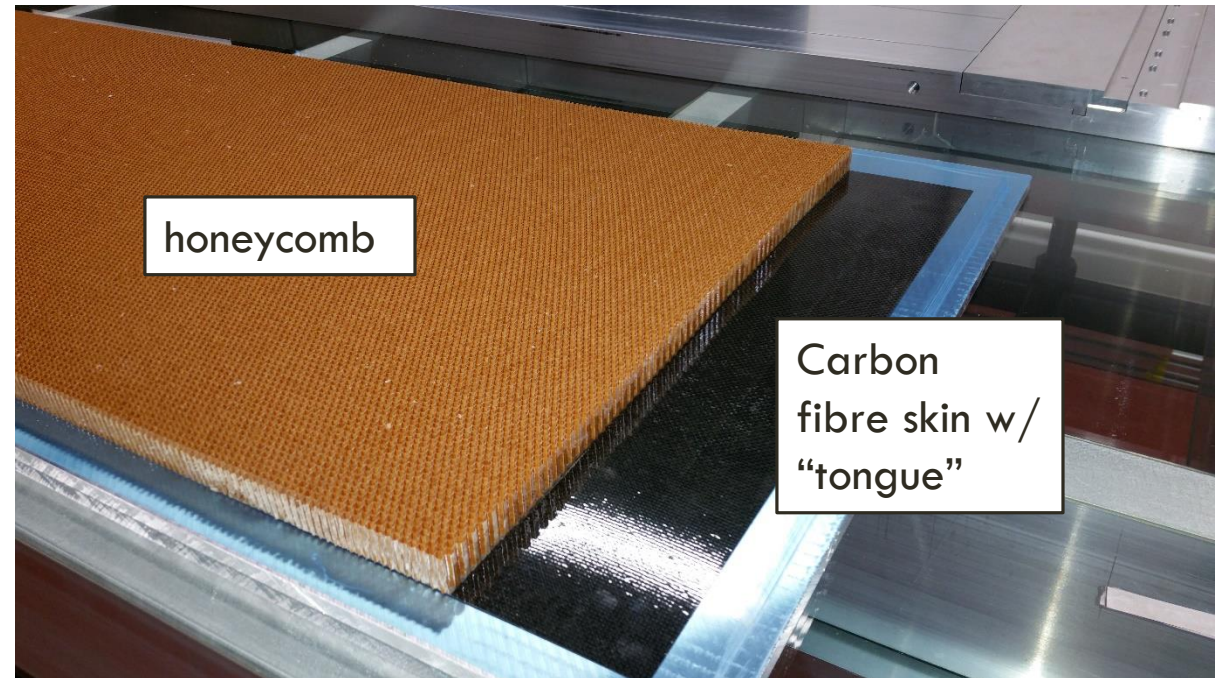

SIDEWALLS (U-PROFILES)

CFRP with a black polyimide foil

QA

- Check overall dimension
- Check quality of gluing of the light tight polyimide foil

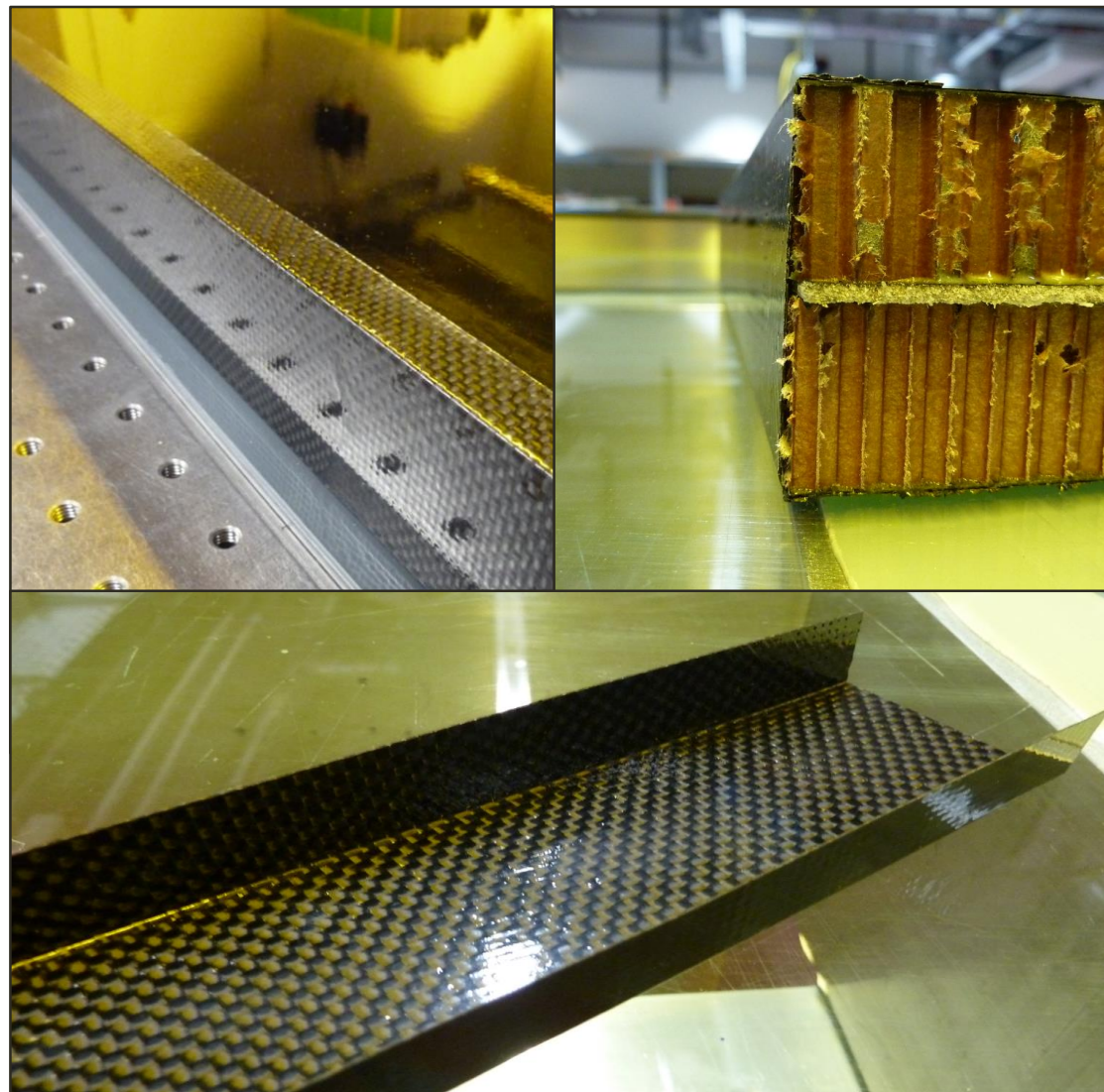
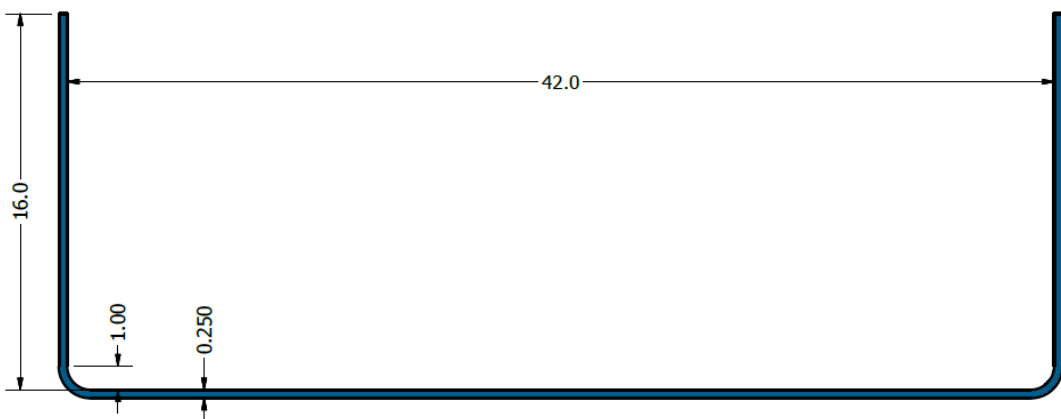

ENDPLUG PRODUCTION

Description: 2 Types (Light injection side and mounting side)

Rough material EN-AW5083 AlMg_{4,5}Mn_{0,7}
“gegossen und feingefräst” 25 x 145 x 530 mm

At least 3 axis machine (faster on the 5-axis)

Production steps

- Start with excess material removal
- Machine outer dimensions
- Precision shapes (LIS, pin holes)
- Rough glued surface (also sealed surface for coldbox)
- Cleaning (Holes)

QA

- Step for endpiece (5,7mm)
- Check precision holes for pins and mounting and also depth of threaded holes

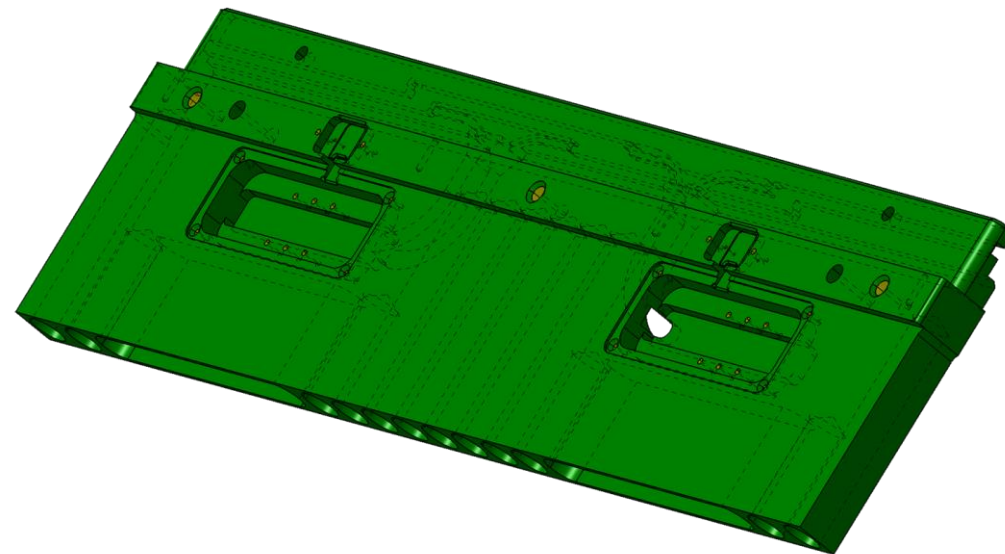

COLD-BOX FLANGE

Rough material EN-AW5083 AlMg4,5Mn0,7 “gegossen und feingefräst” 55 x 12 x 530 mm

Production steps

- Water jet outer and inner shape
- Milling of Holes
- Polishing coldbox interface surface
- Rough glued/light tight surface

QA

- Check precision holes (depth...)

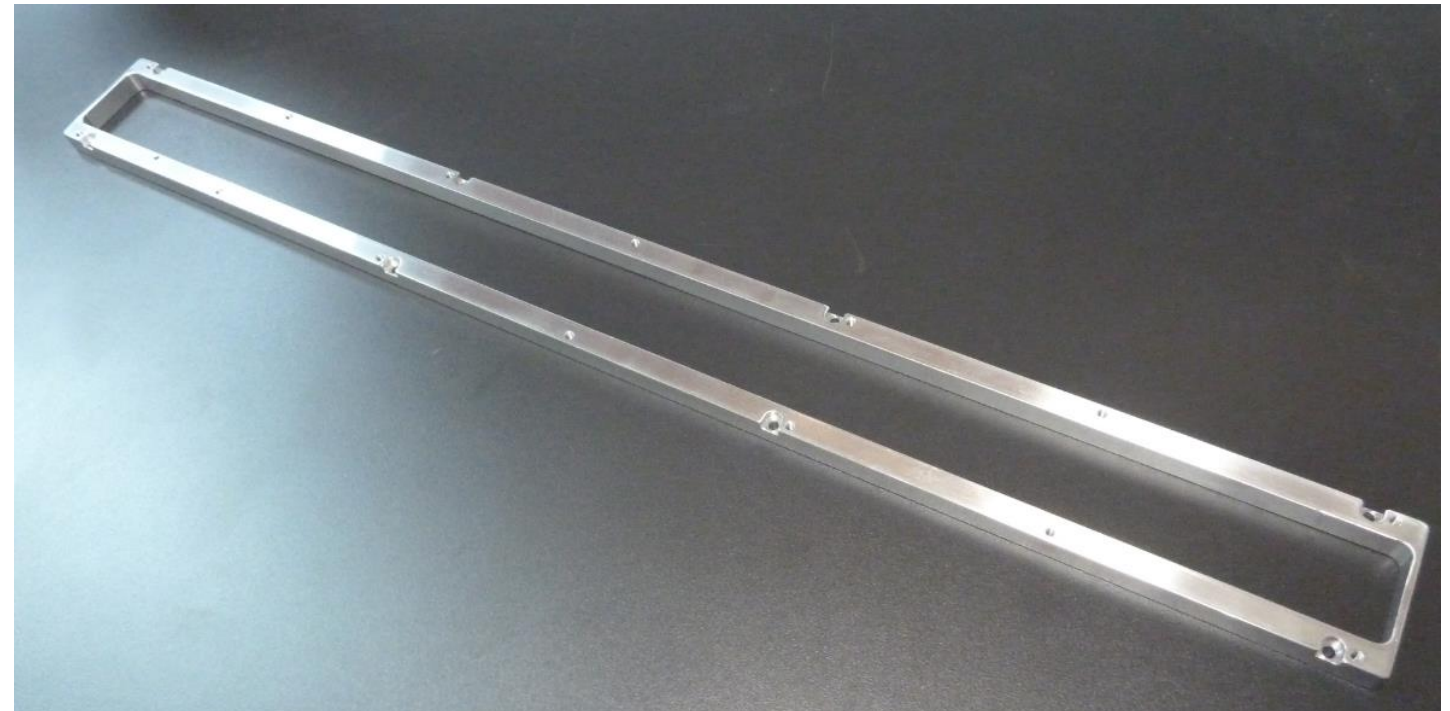

FIBRE MAT: LONG CUTS

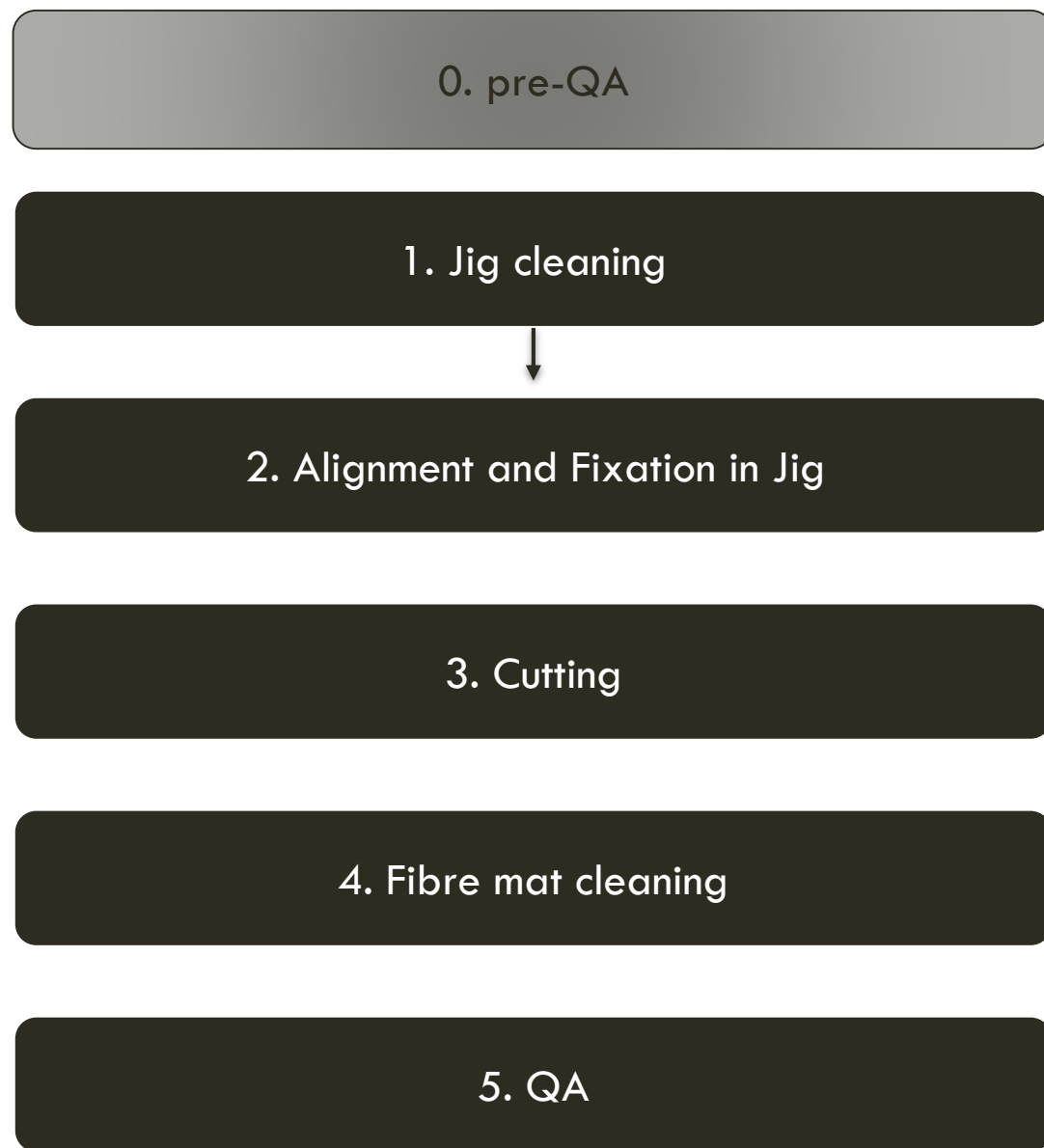



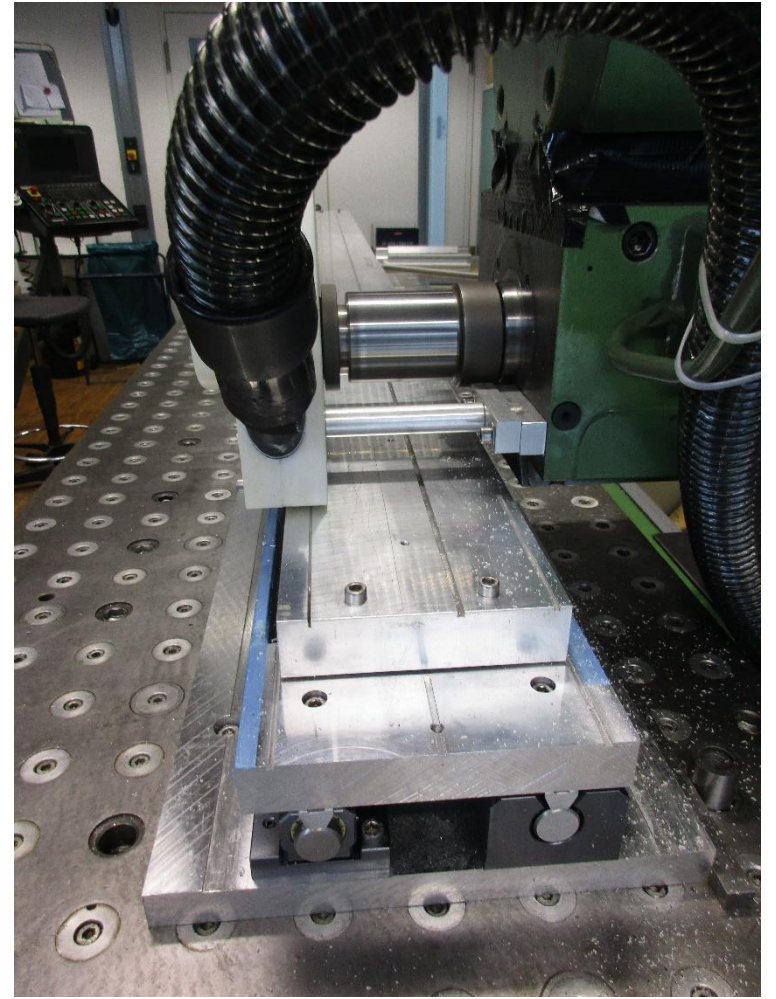

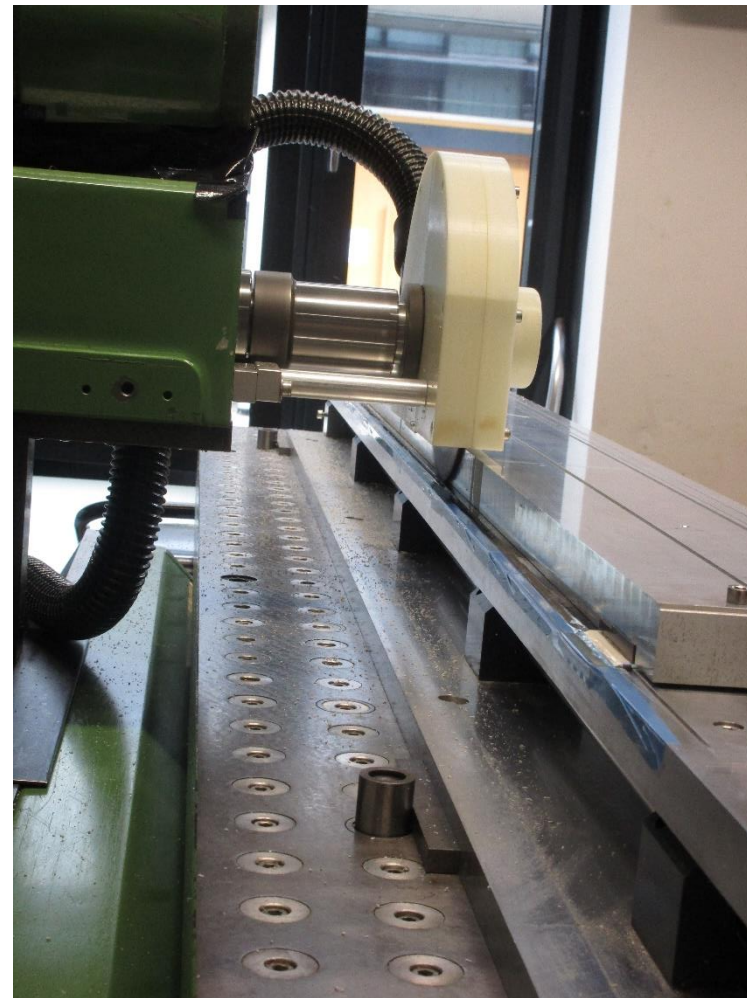

FIBRE MATS: LONG CUTS

Parts

- Blade (helical disc cutter HSS $\text{\O}200$ mm x 3 mm)
- Machine with 2,5m travel or special device (HD tool)
 - Precision (0,05mm over 2,5m)
- Cutting jig (bottom and top plate)

Production

- Time: 0,75 h per mat
- Labour: 1.25 FTE people

QA

- Geometry check
- Beta source
- UV/Optical Scan
- See Sebastian's slides.

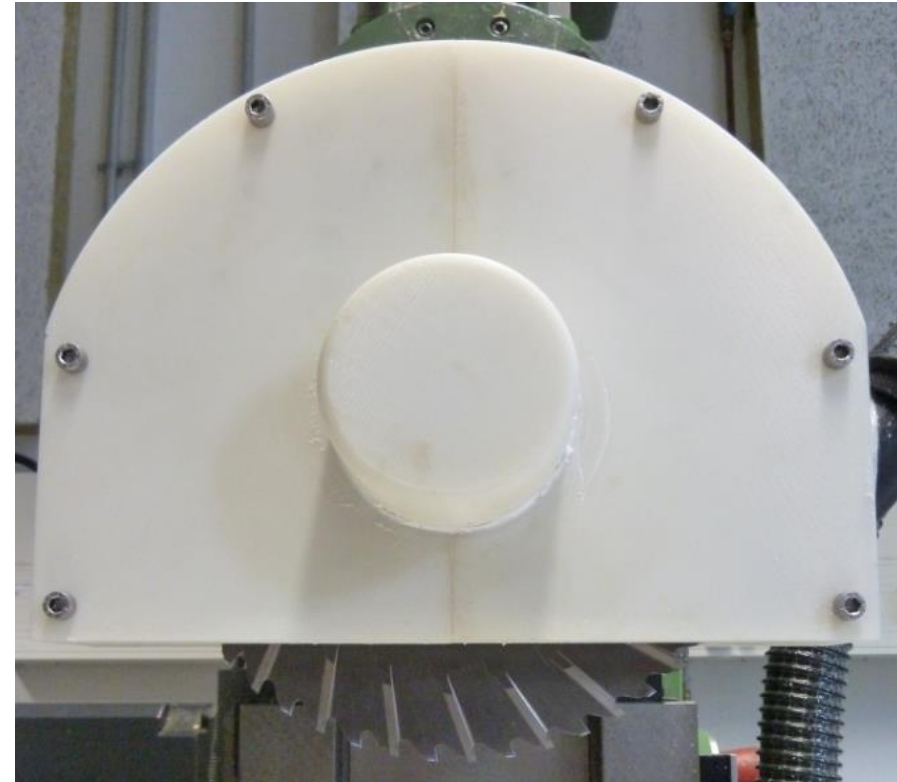

LIGHT INJECTION BARS

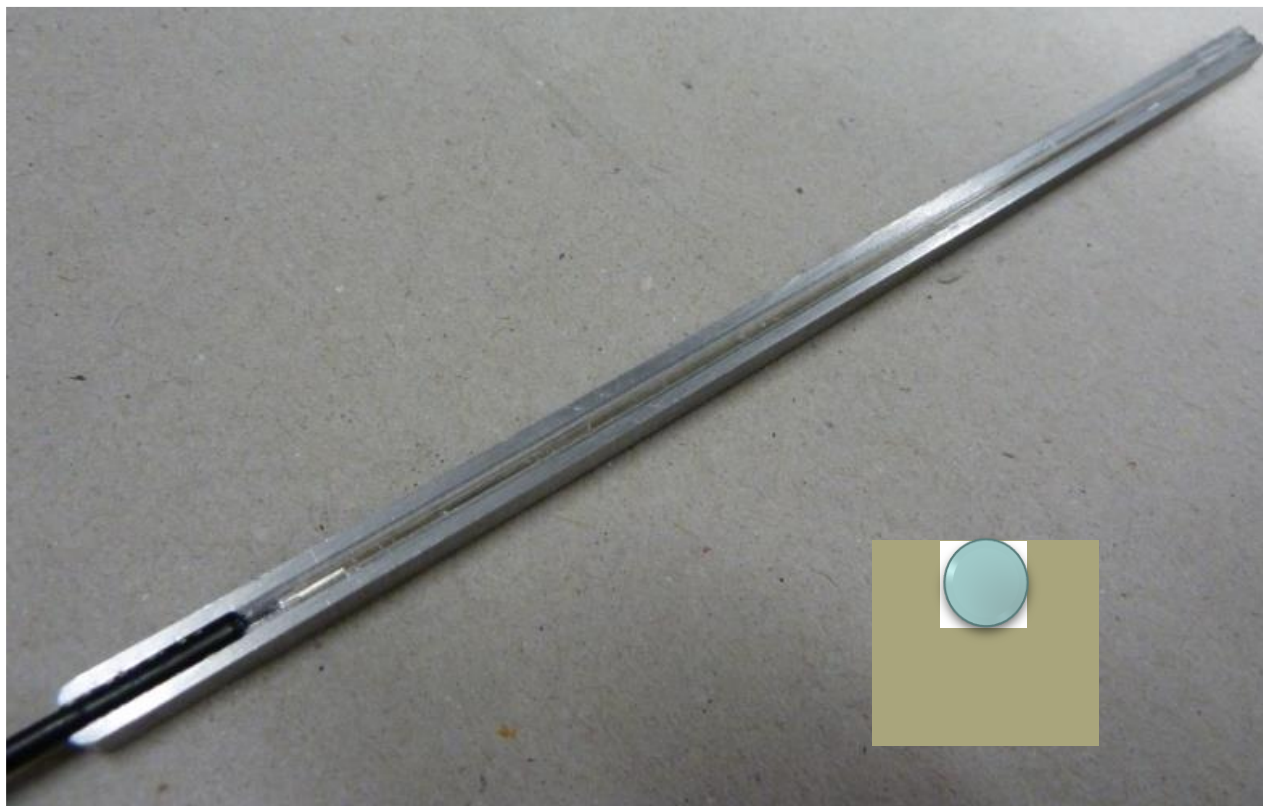

Add sketch

1. Cut and Strip jackets from 50cm fibres

2. Clean alu bars and grooves

3. Apply EPOTEK 302-3M glue

4. Clamp into Jig – wait 24hr

5. Scratch

6. Glue Mirror

7. QA

PRODUCTION OF LIGHT BARS

Currently hand work, takes a few minutes to scratch each one, glue hardens overnight

- Uniformity is a concern; seems to be ok in the first 25 produced

Have to place order for 1152 metal holders still (or make them all in house...)

Require ~24 / week (HD + Nikhef)

- 500m of 2.2mm jacket 1mm single core (Hitronic Lappkabel) fibre in stock at HD
- Need ~4m / module (600m)

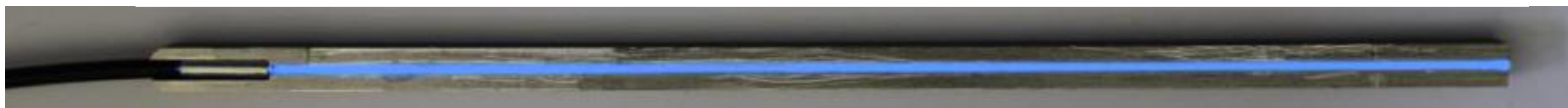
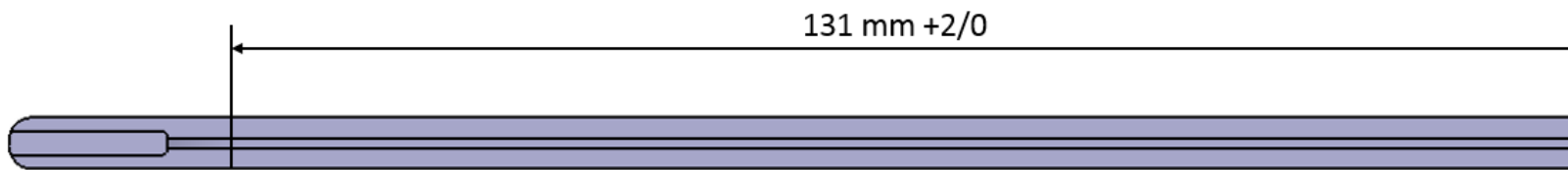

Scratching too much length will result in light going from the light injection bar to a neighboring mat. Maybe not a problem?



LIGHT INJECTION BARS

Production

- Time 0,75h for 8 pieces
- Labour: 1 FTE person

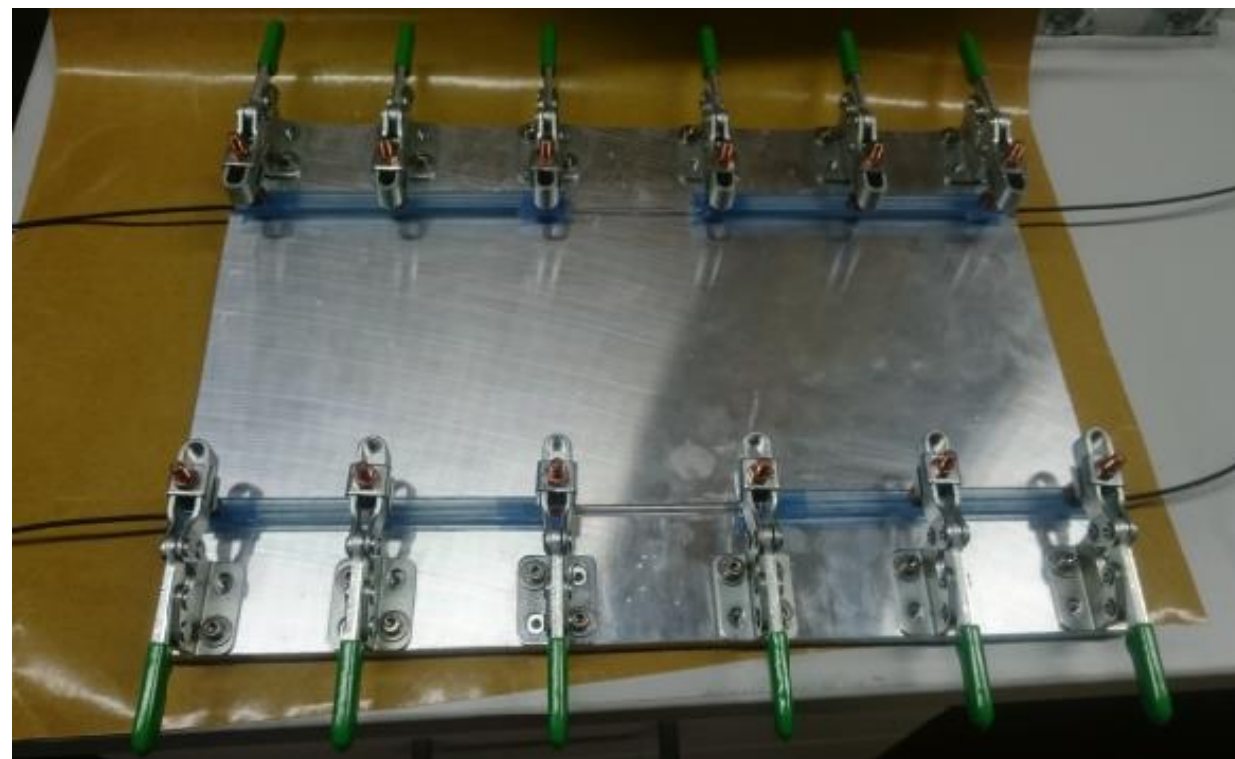

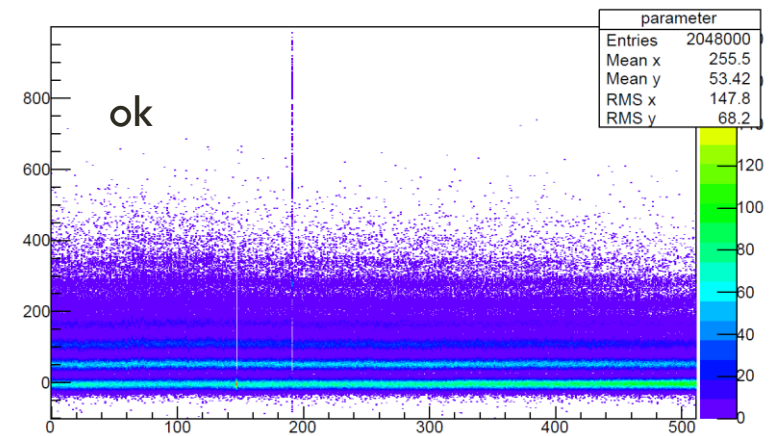
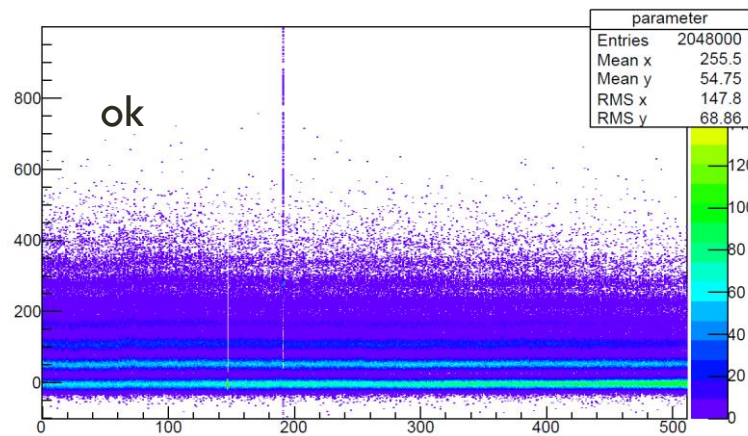
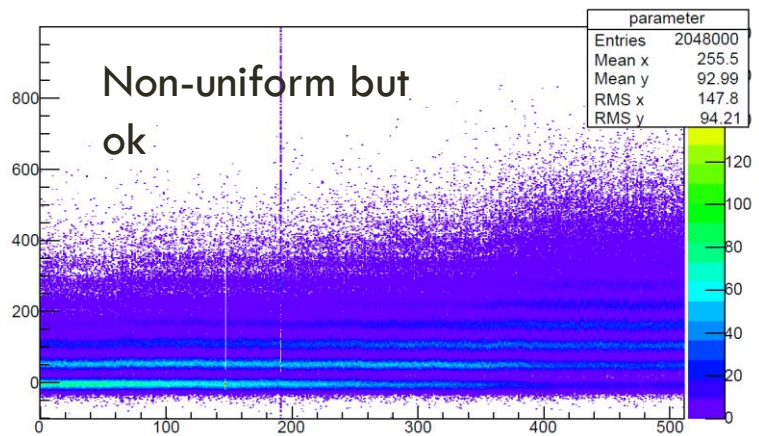
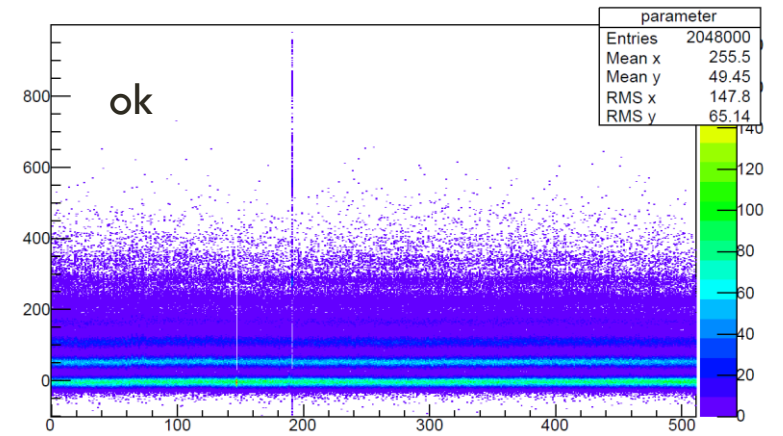
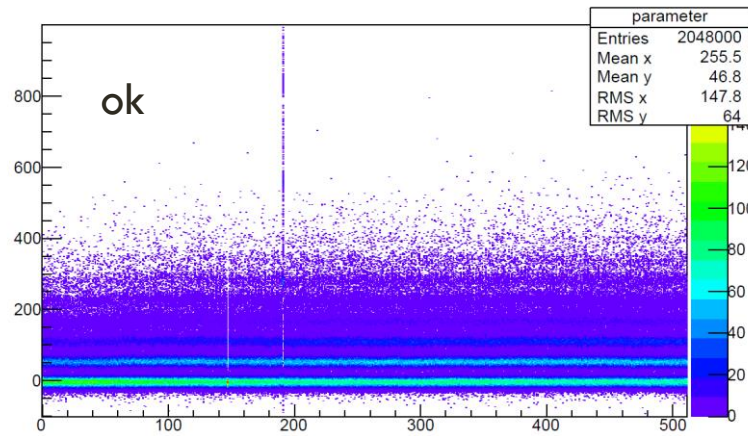
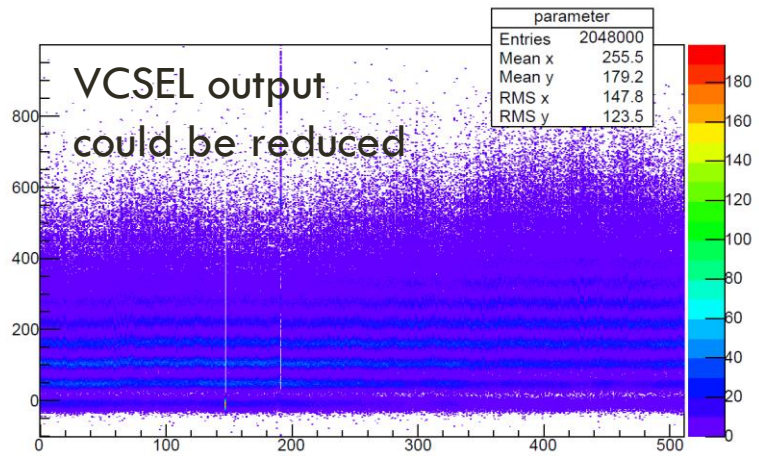

- We want the 1 p.e. peak = 0 p.e. peak (too much light draws too much current)
- Still want to be able to see the 5 p.e. peak.

LIGHT INJECTION BARS IN ENDPLUG

Parts

- Equipped Lightbars
- Endplugs

- Araldit AW116
- Syringe
- Teflon spacer
- Fastening clamps
- Al-bars protected with PET -tape



LIGHT INJECTION ENDPLUG

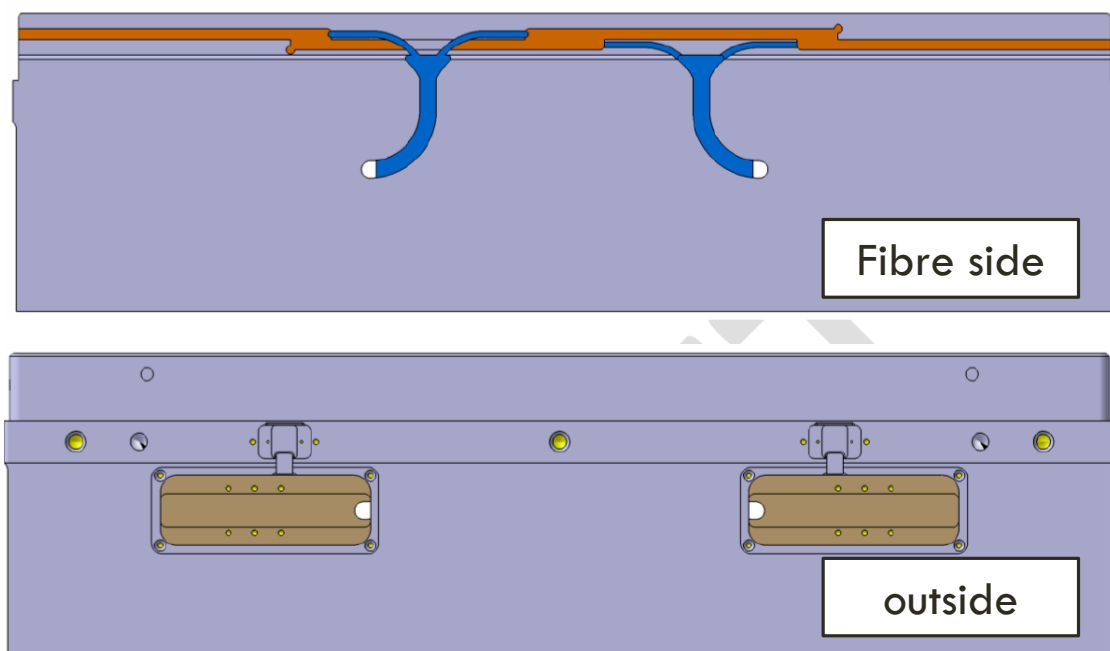

1. Roughen surfaces and clean

3. Combine two light bars with shrink tube

4. Apply glue

5. Insert light bars

6. Clamp and wait

7. QA(functionality test)

LIGHT INJECTION ENDPLUG

Production

Time: 0,75 for both endplugs

Labour: 1 FTE person

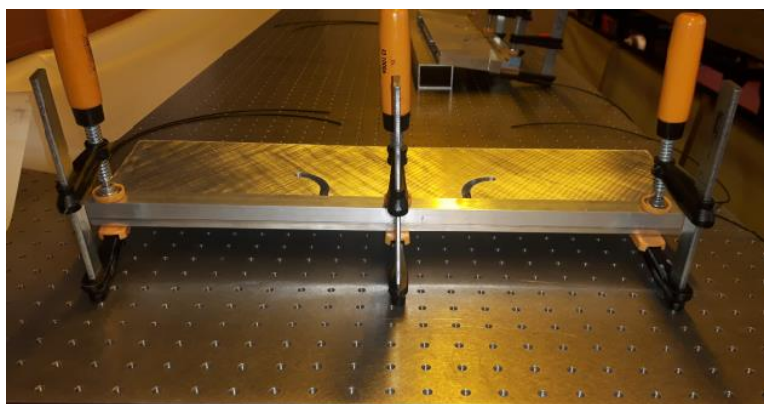

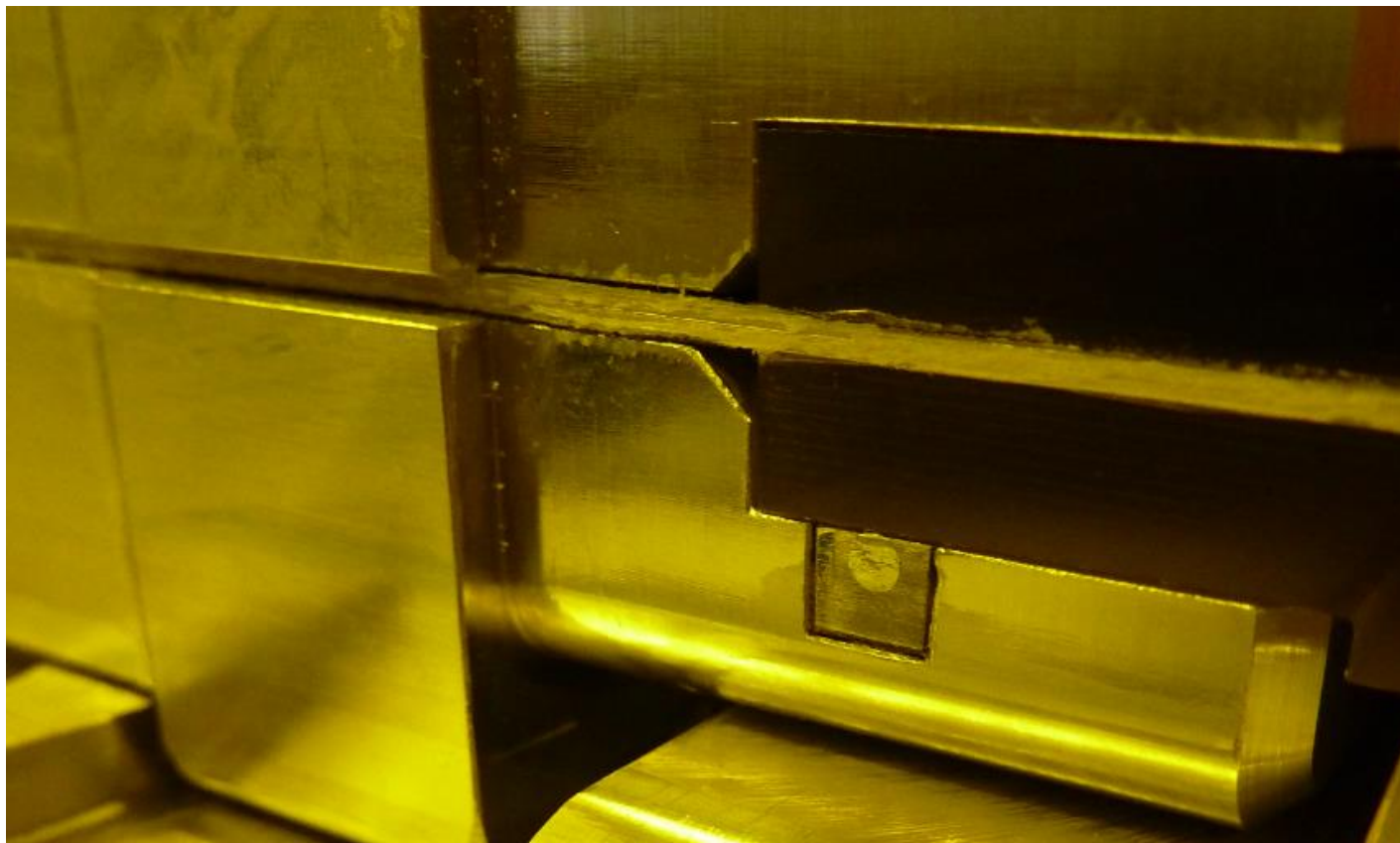

TEMPLATES AND TOOLING

TOOLING AND TEMPLATES

We have currently produced four 5m modules with the current template

- dummy module
- Glue cast mat module (EDR module)
- Module -1
- Module -0

Some handwork has been done on the current templates

Plan to produce two new template sets

- Allows for inserts
 - Allow for alignment of panels
 - One set for Heidelberg and one for Nikhef
-
- Duplication of the tooling will also be done for Nikef

THE ALIGNMENT TEMPLATE

A single 5m aluminium alloy plate machined on a 7m machine

Non-stick agent applied semi-regularly

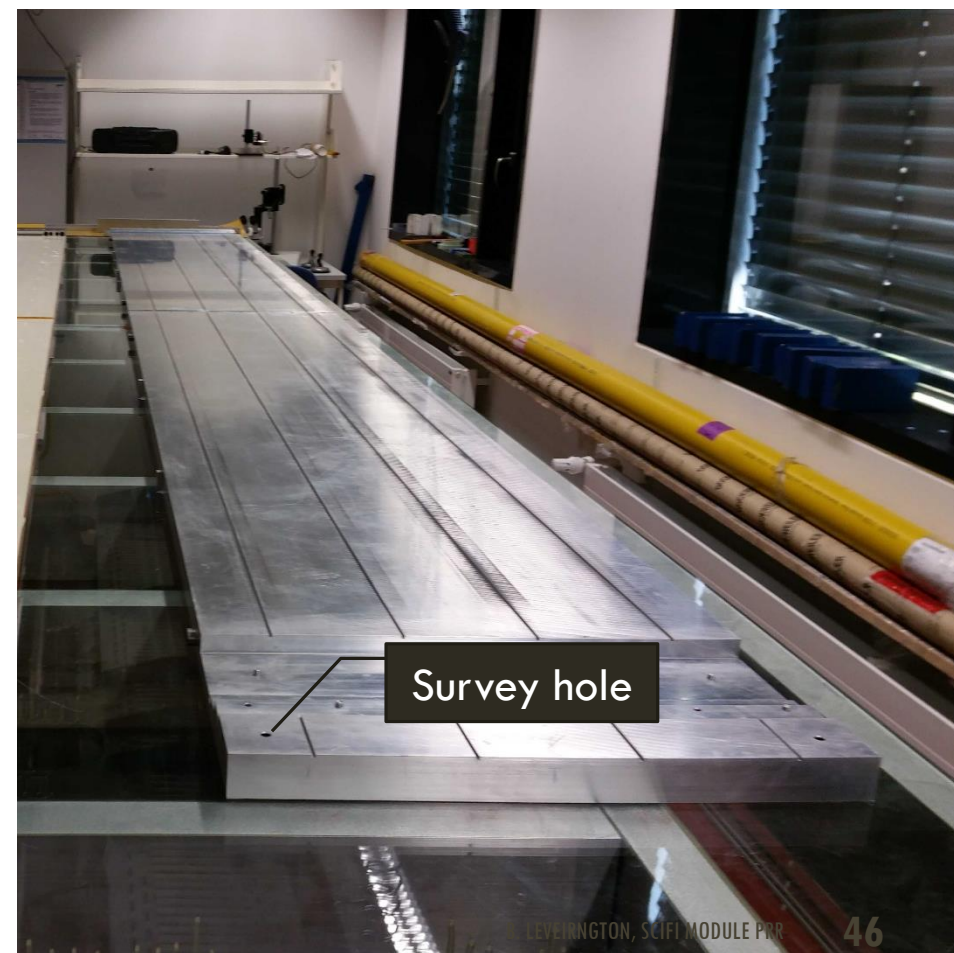
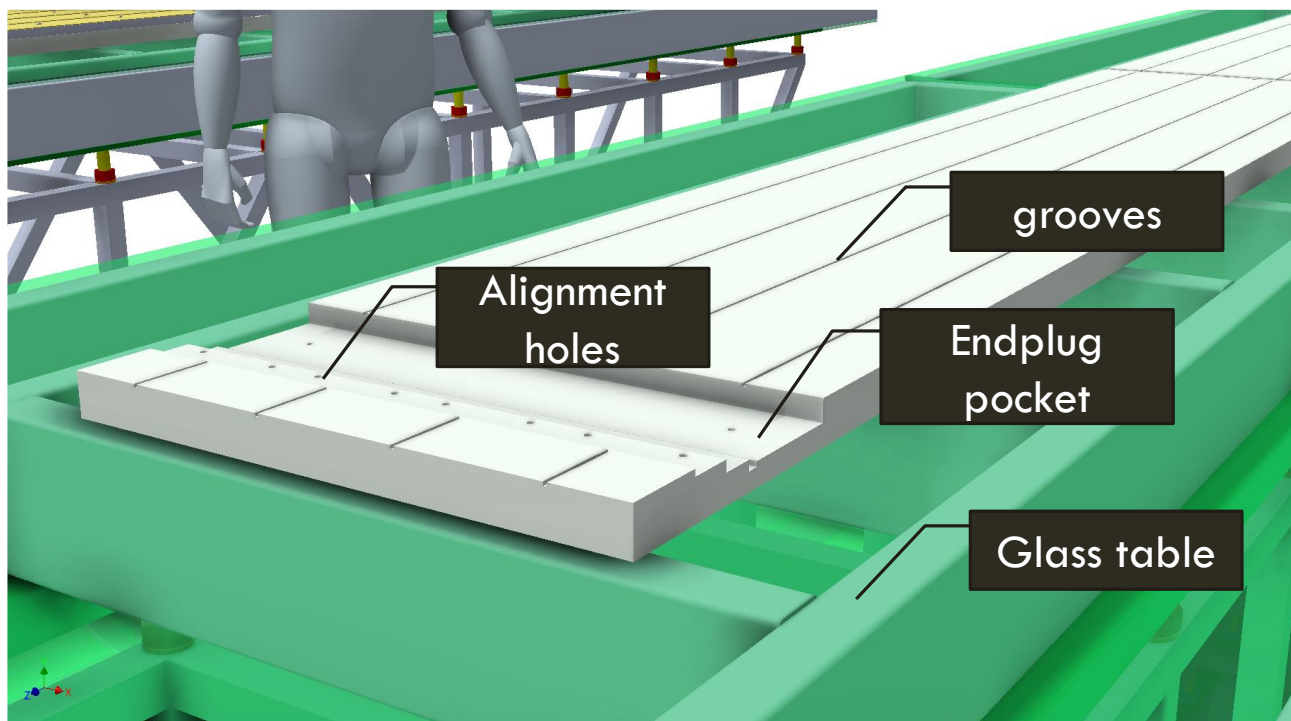

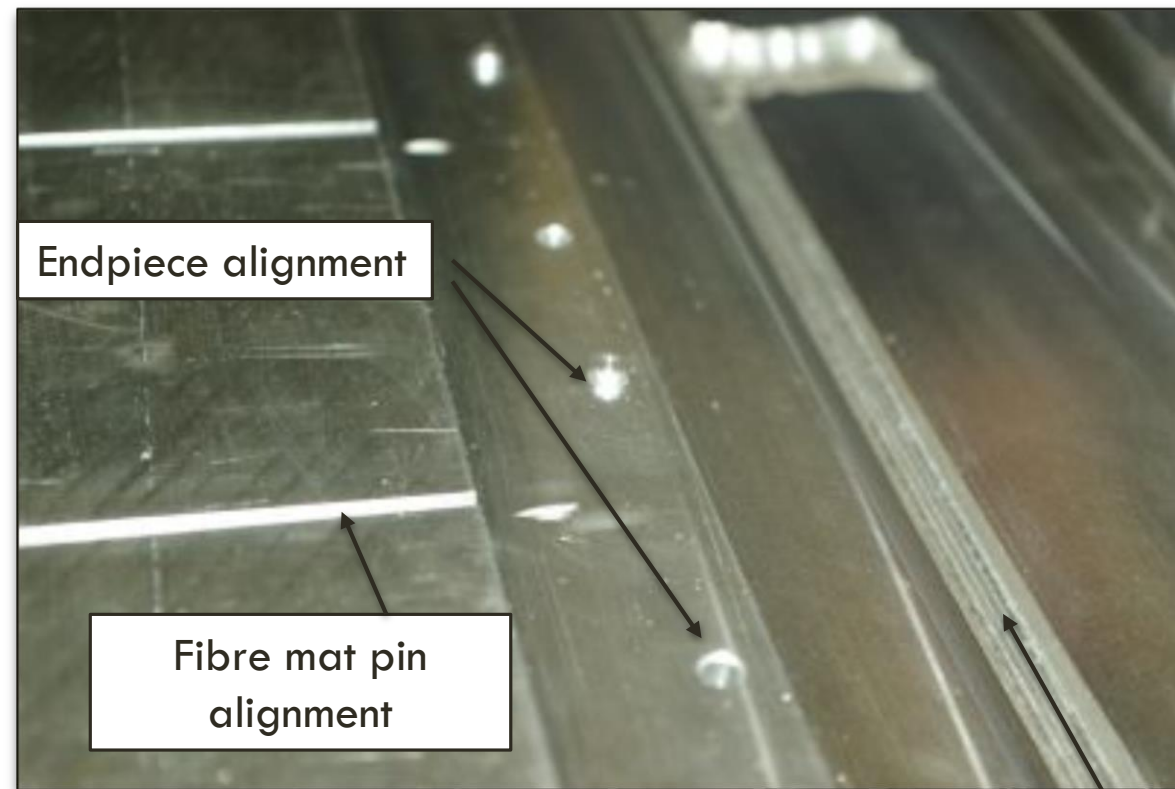
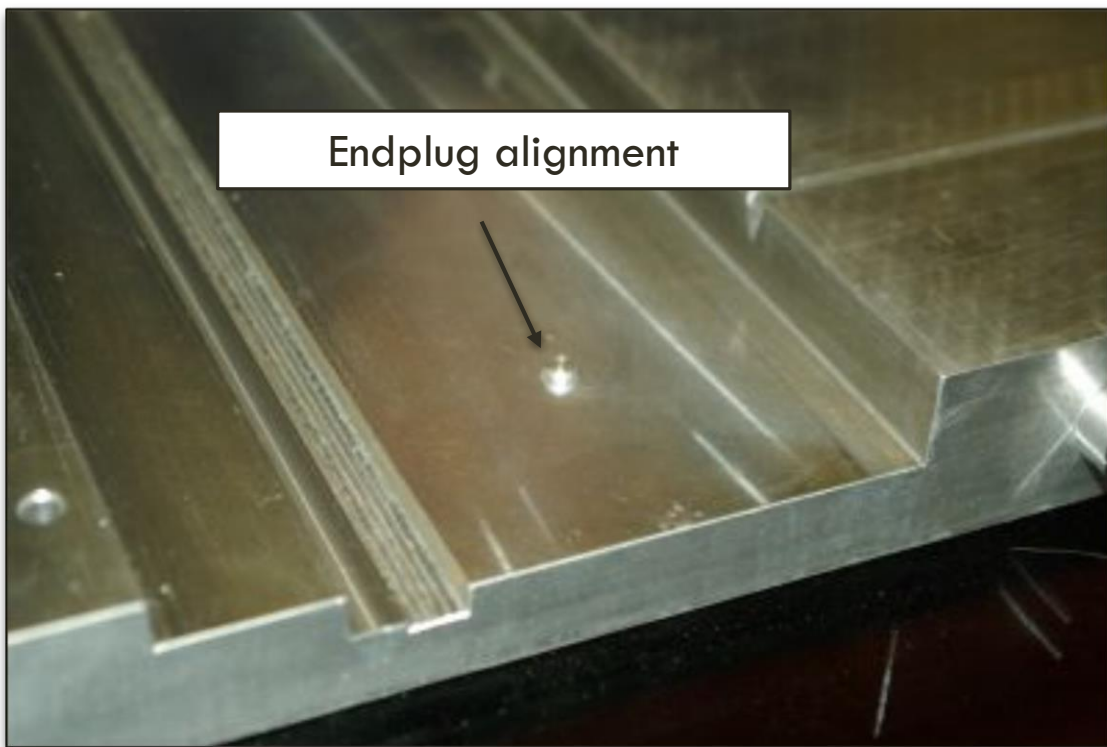

Hand machining

TEMPLATE FLATNESS

Theodolite measurement before the EDR

Follows a similar shape of the glass table.

Min-max = 150 micron. Std Dev = 31 micron

Can be improved (tables are adjustable), but within specs

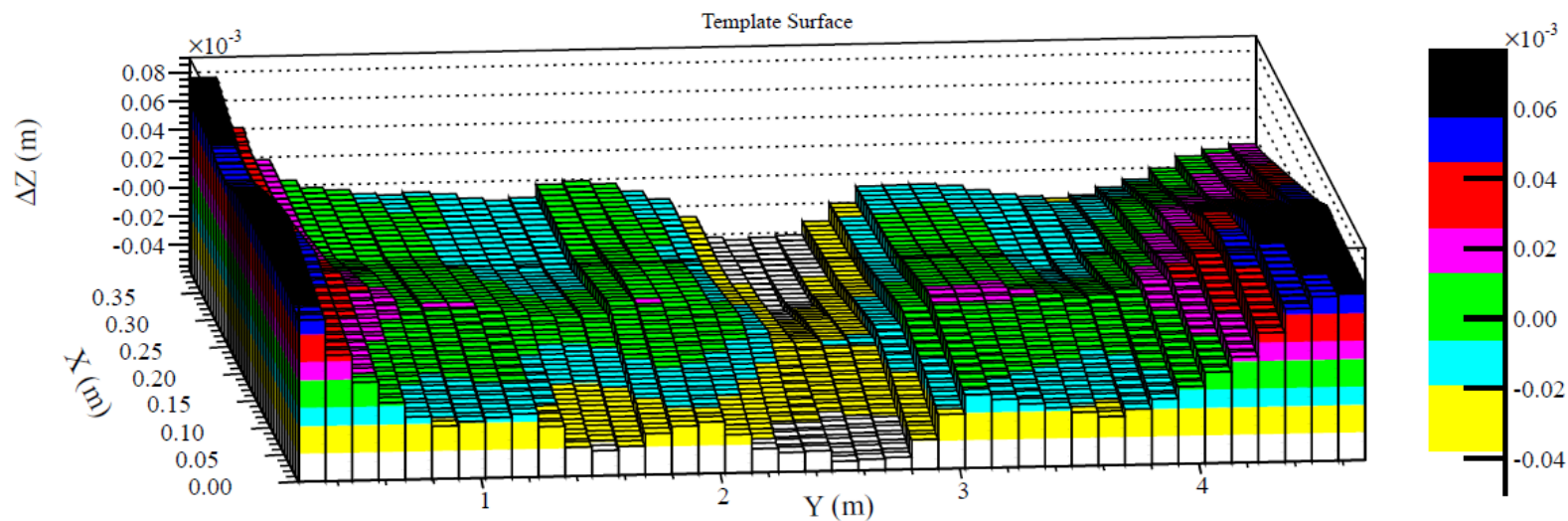

Figure 4.15: The flatness of the aluminium template as measured by CERN EN/SU/EM.

GROOVE LINEARITY

Std. Deviation ~ 15 micron

Min – Max deviation ~ 35 micron

Conclusion: **within specs.**

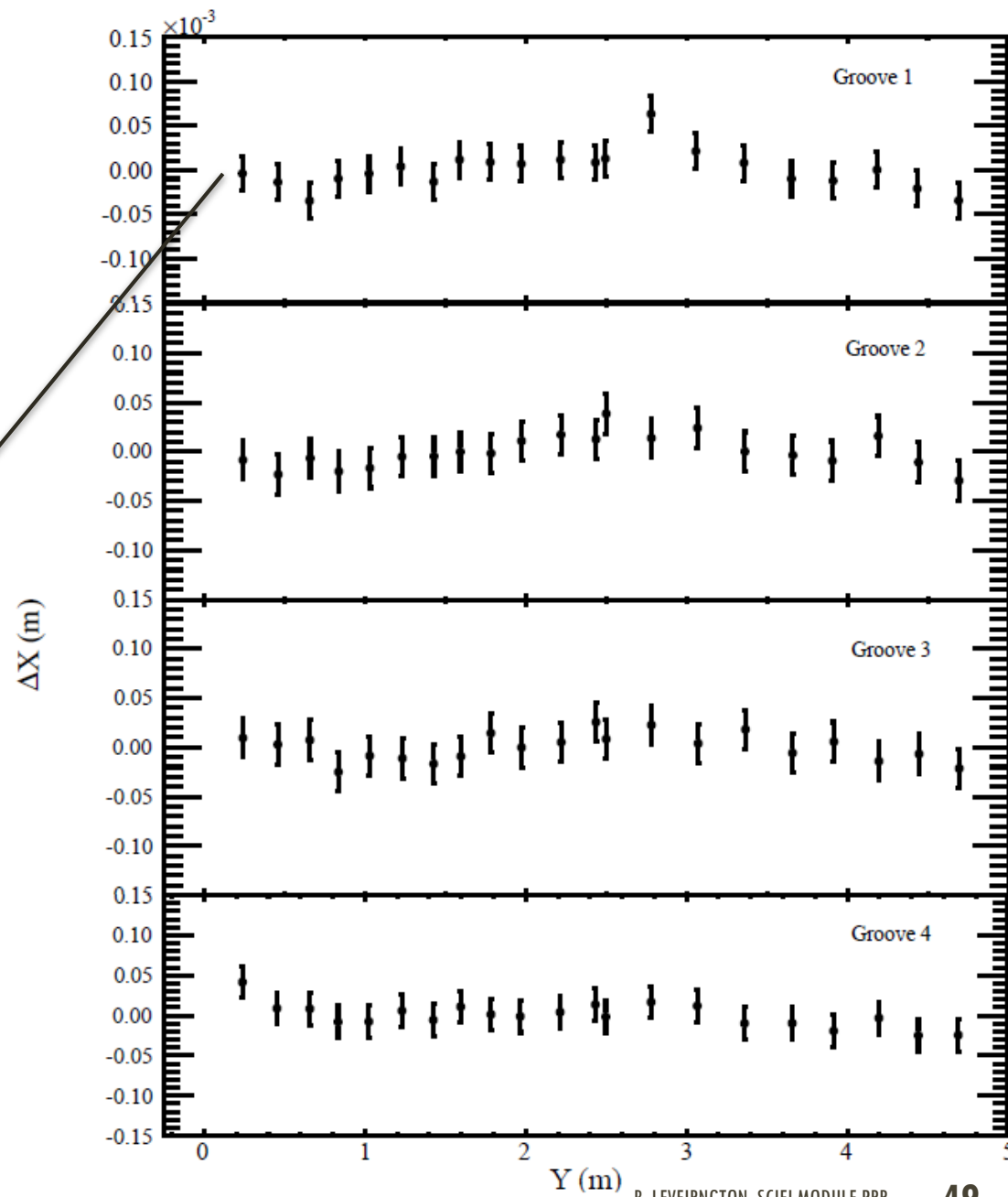
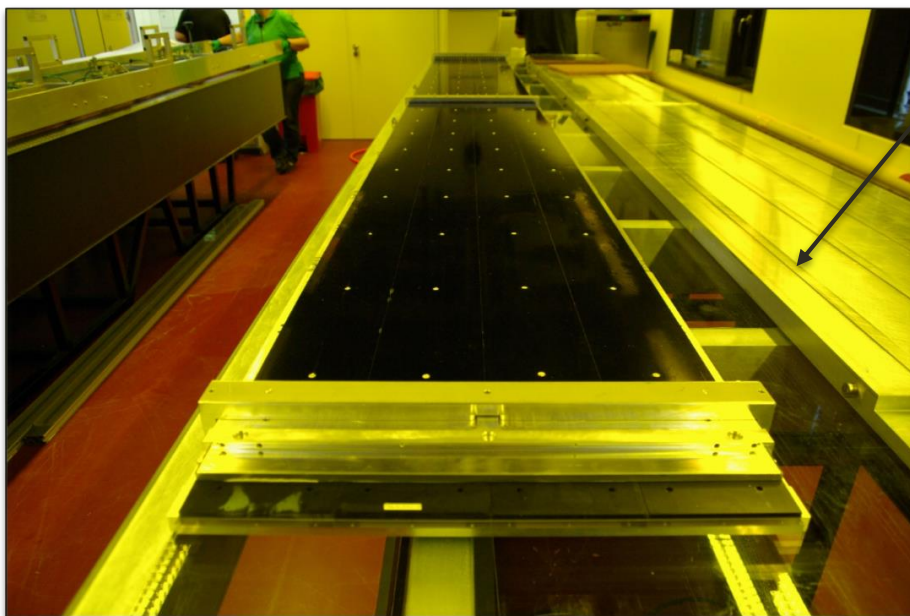

LIFTING AND TURNING DEVICE

Description

- Fixing half panel by vacuum and screws on endplug
- Sliding rails lifted up by pressurized air
 - Push half panel on template for second gluing step



LIFTING

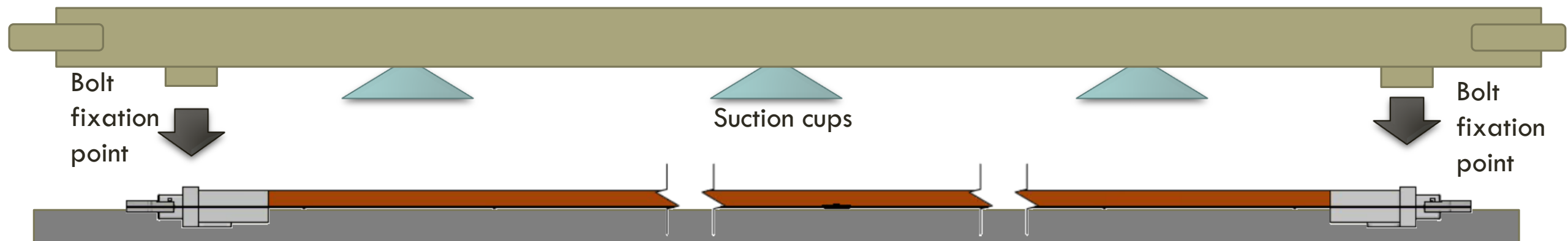

LIFTING AND TURNING DEVICE

- 12 suction pads dispatched over the module length to hold the module while handling it.
- 4 sliding rails to elevate the half module avoiding friction of suction pads during sliding the panel to the jig. It also insures the right height wrt. To the jig.

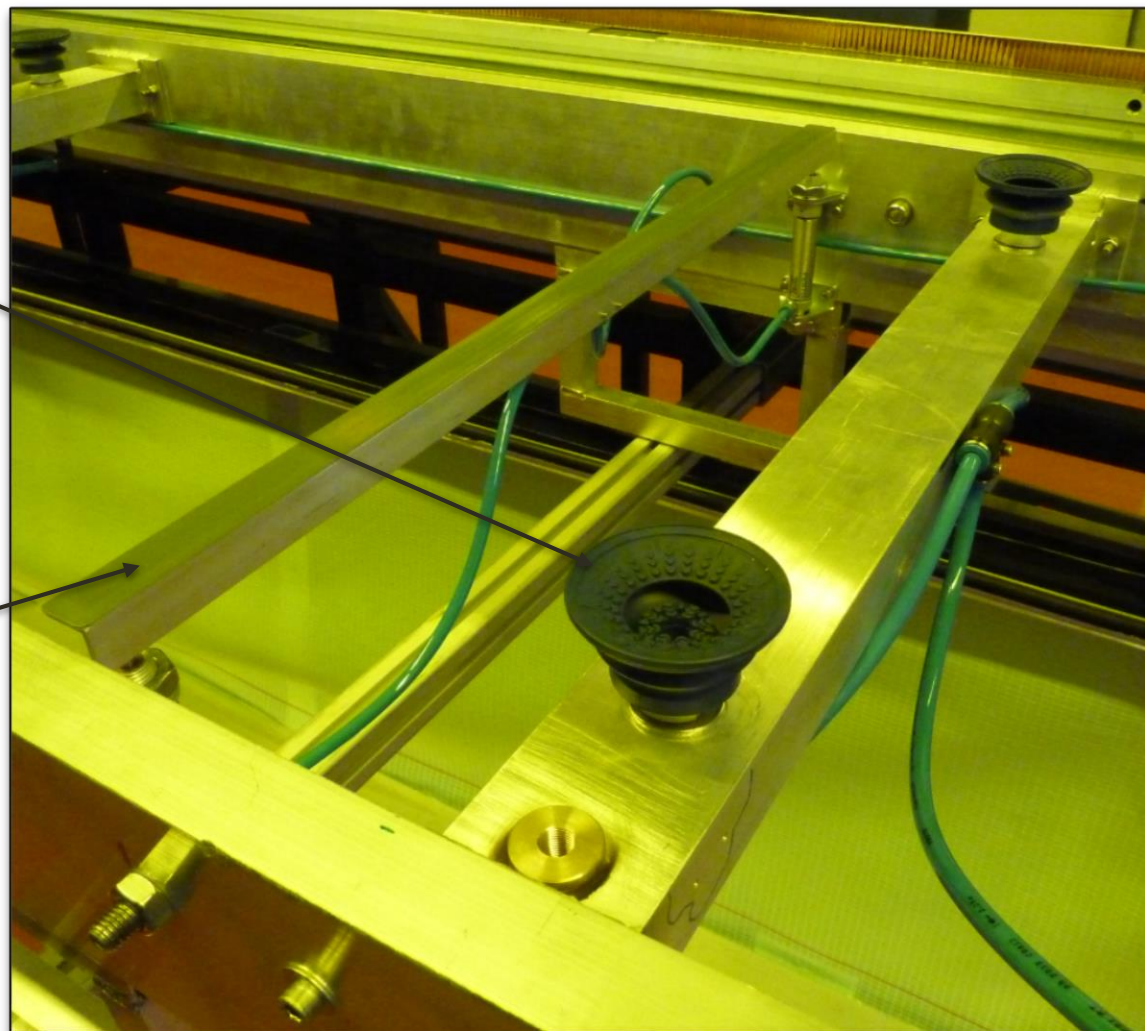

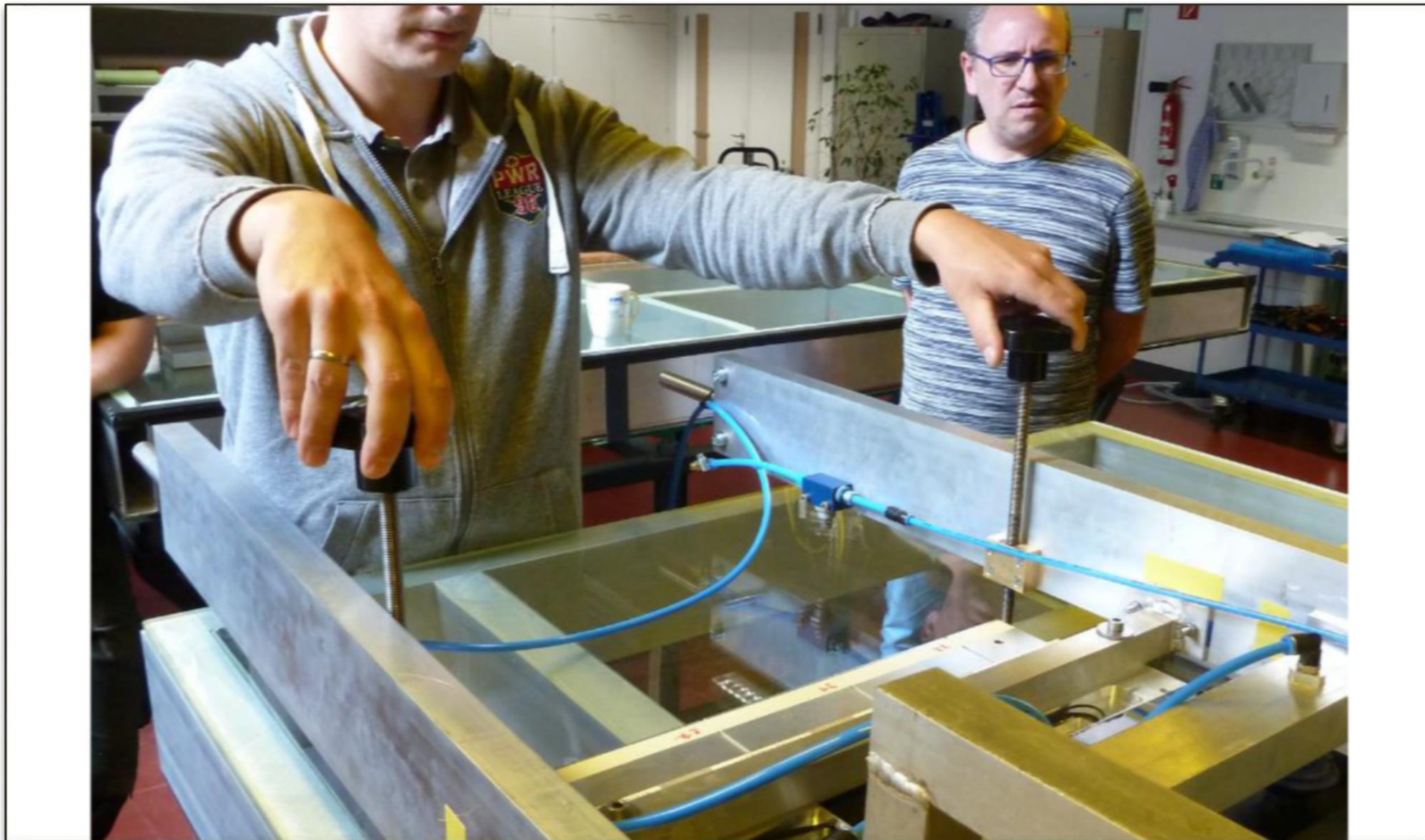

SECOND TEMPLATE

Description

- Essentially a flat plate with a few precision holes
 - Aligns the module again after turning via bridges and pins
 - Flexible in the 2mm gap between halves
-
- New version will check/ensure total module with including sidewalls

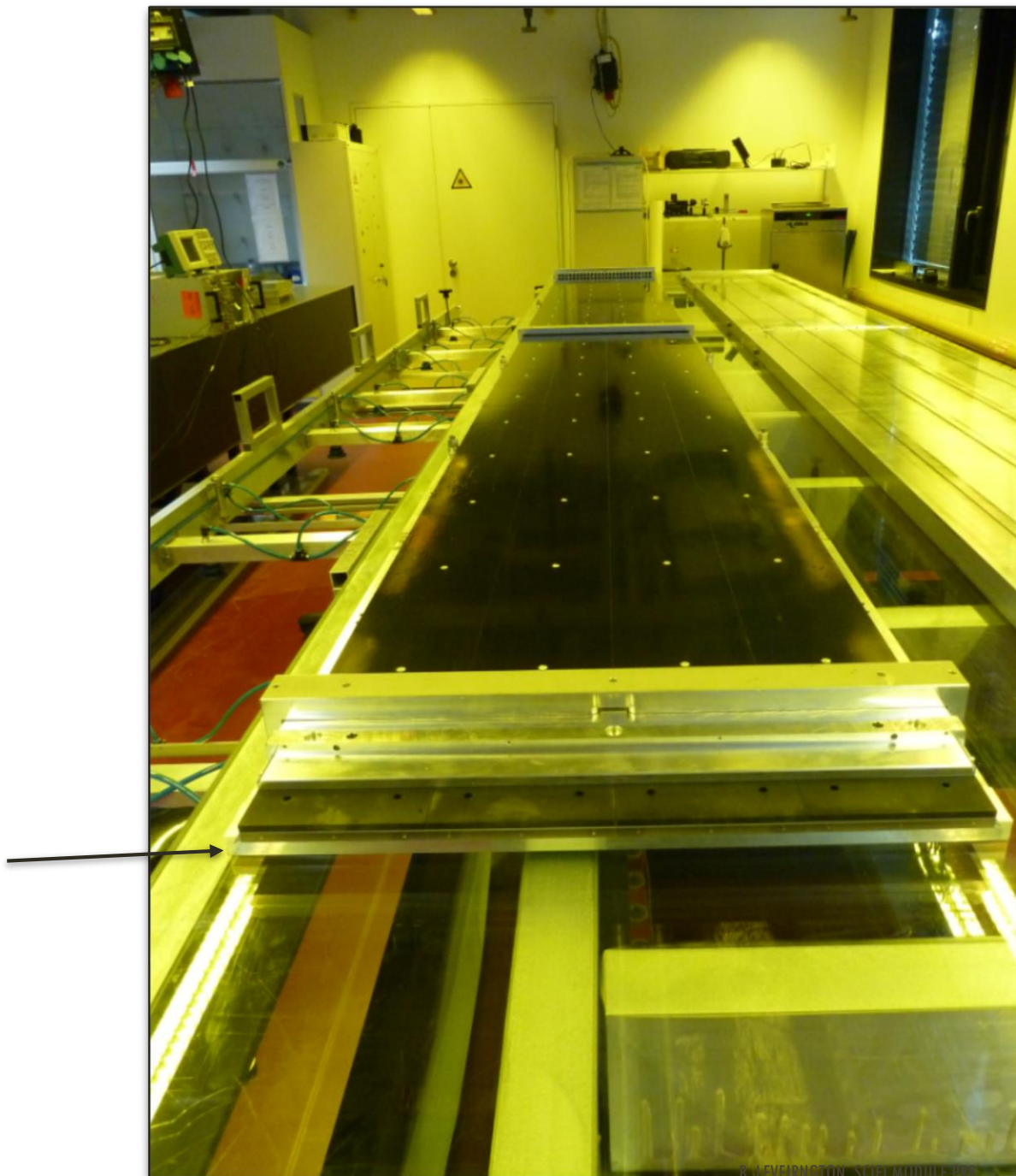

SECOND TEMPLATE & BRIDGES

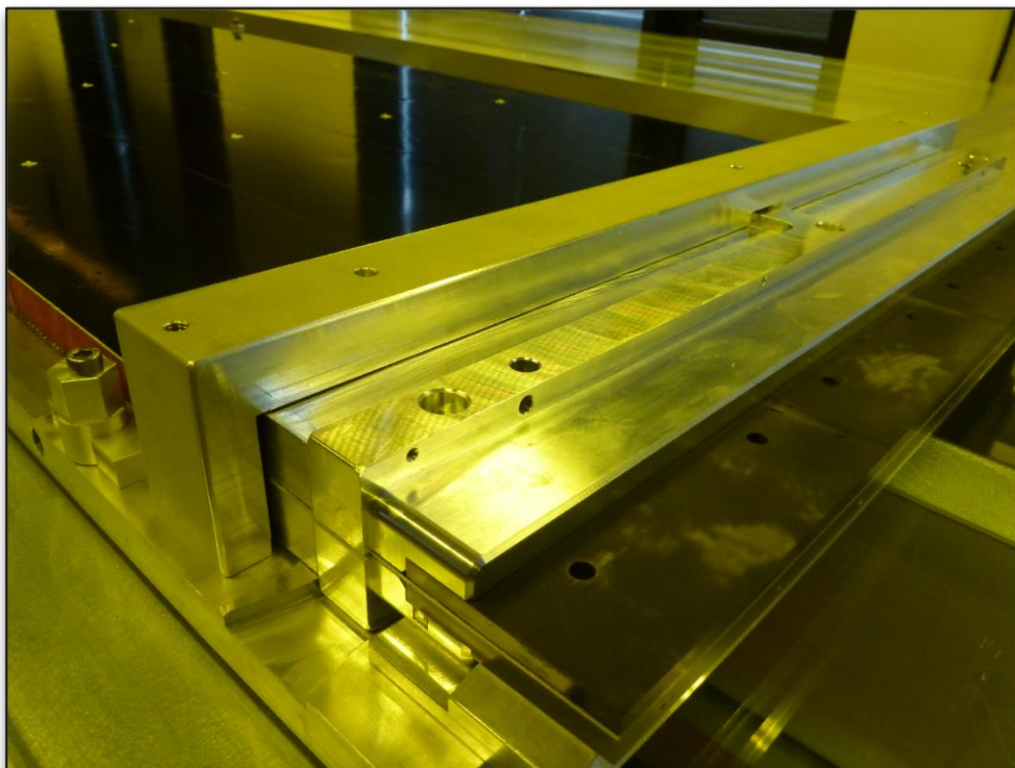

Bridges align the module

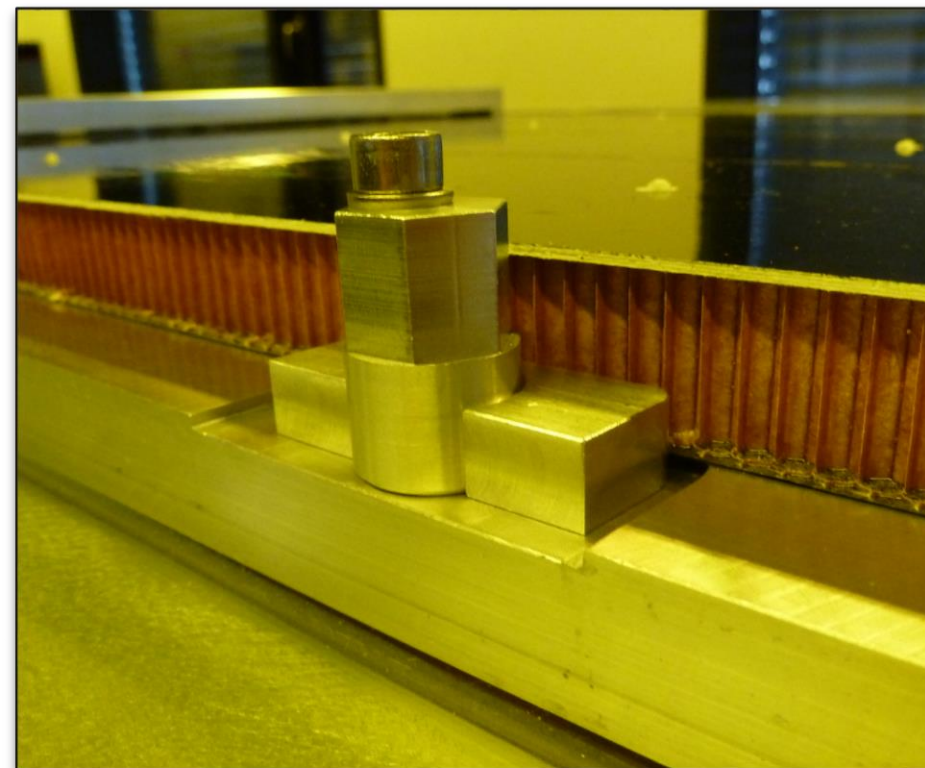

For fixation only (not alignment)

MODULE PRODUCTION

MODULE PRODUCTION WORK FLOW

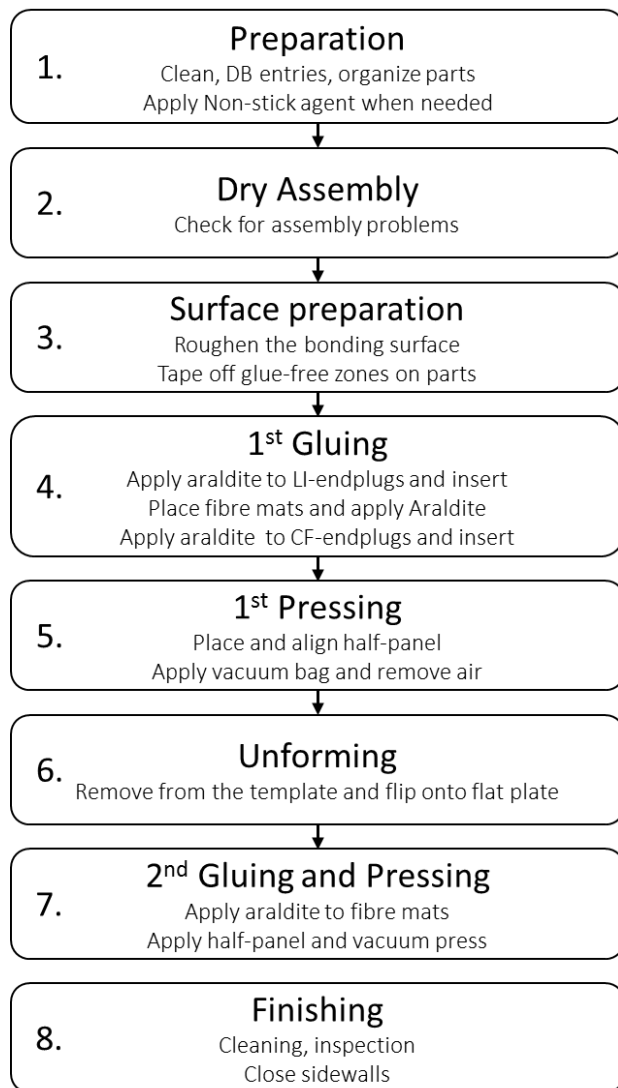

MODULE ASSEMBLY

Preparation Time: 2 hours

Assembly Time:

1.5 hours for 1st gluing step

1.25 hours for 2nd gluing step

FTE needed 2.5 (2 for gluing process, 0.5 as assistant)

PREPARATION

- Prepare jigs with sealer agent Mikon 199 (12 h curing), then with release agent 205 (12 h curing)
- Prepare dowel pins and bridges
- Dry assembly (same steps than gluing of 1st step but without glue...)
- Cleaning
 - Dust the jigs, panel, mats and Endplugs (no alcohol on the jig!)
 - Clean mats and Endplugs with Isopropanol

1ST GLUING

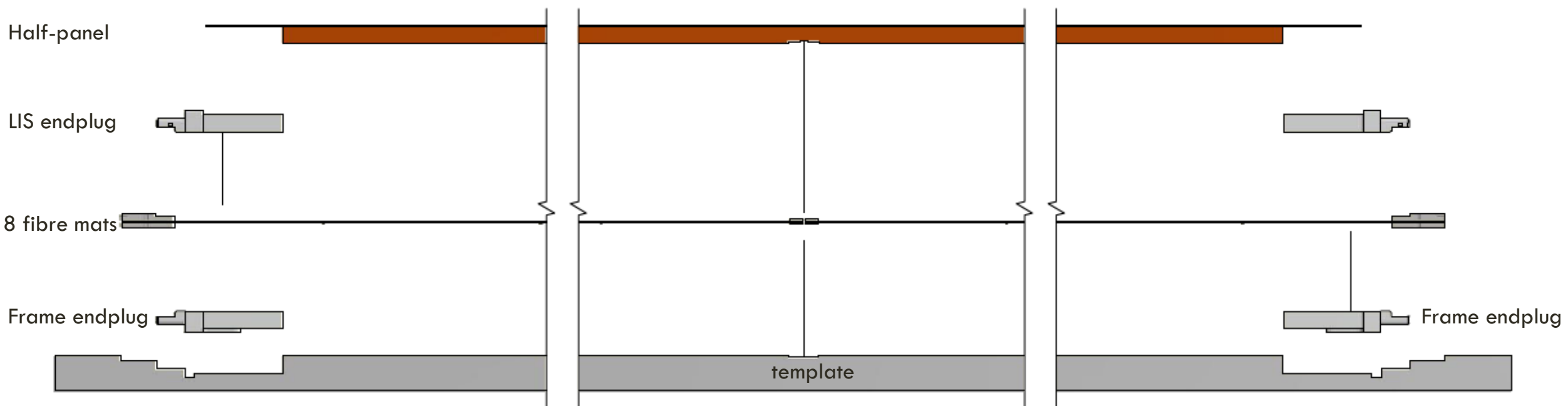

1ST GLUING STEP: MATS, PANEL 1, ENDPLUGS

Prepare the glue Araldit 116 (prepare 800gr; approx. 750gr needed)

Apply glue (Glue Araldit 116) with foam roller on Endplugs mounting side (also on step for endpieces)

Place Endplugs mounting side in GJ with dowel pins ($\varnothing 6 \times 13$)

Place Mats in GJ with dowel pins ($\varnothing 6$)

- Record in database (for dry assembly only, mats positions has to be defined in advance)

Apply the glue (Glue Araldit 116) on each mat in sinuous lines and spread with toothed spatula

- Not spread until the borders of each mat to avoid too much glue sticking out between mats!
- Leave the area of the gluing surface for Endplugs Light injection free

Apply glue (Glue Araldit 116) with foam roller on Endplugs Light injection (no glue on step for endpieces)

Place Endplugs Light injection and align with “bridges” to the Endpieces

Place honey comb panel

- Take care of proper positioning

Place silicon paper on junction carbon fiber sheet and Endplugs to avoid glue sticking to vacuum hood.

Place distance holders on top of silicon paper

Place vacuum hood and apply vacuum 0,125 bar

12 h curing time

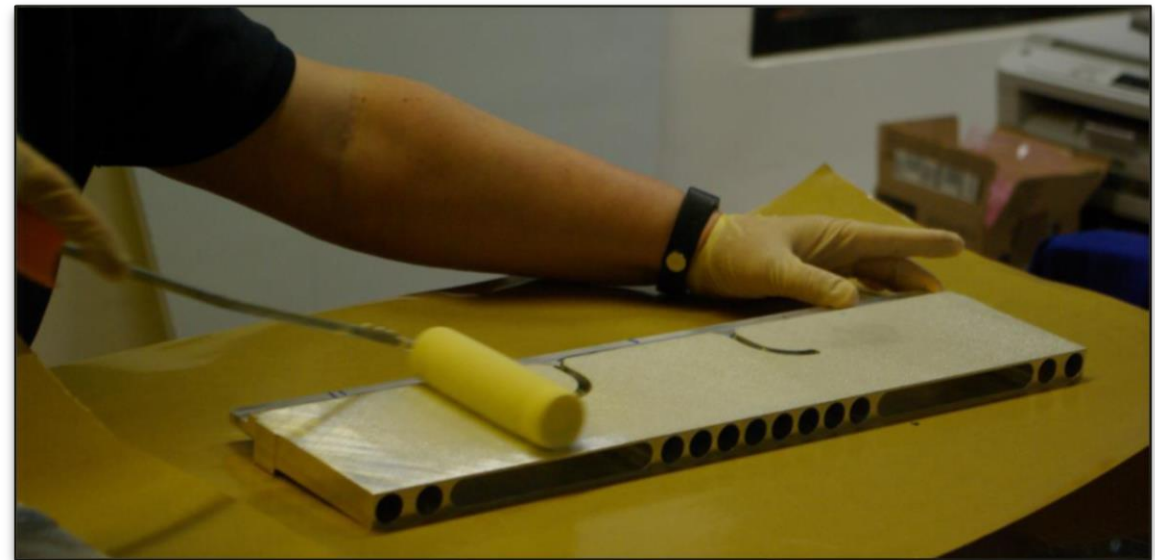

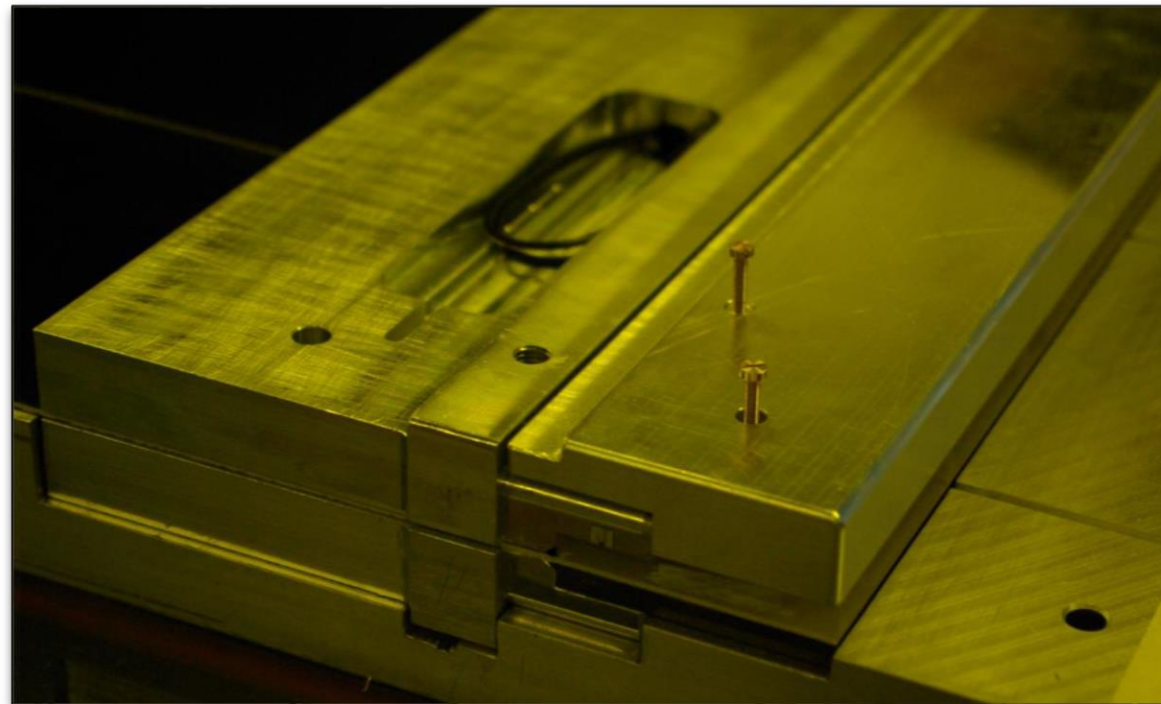

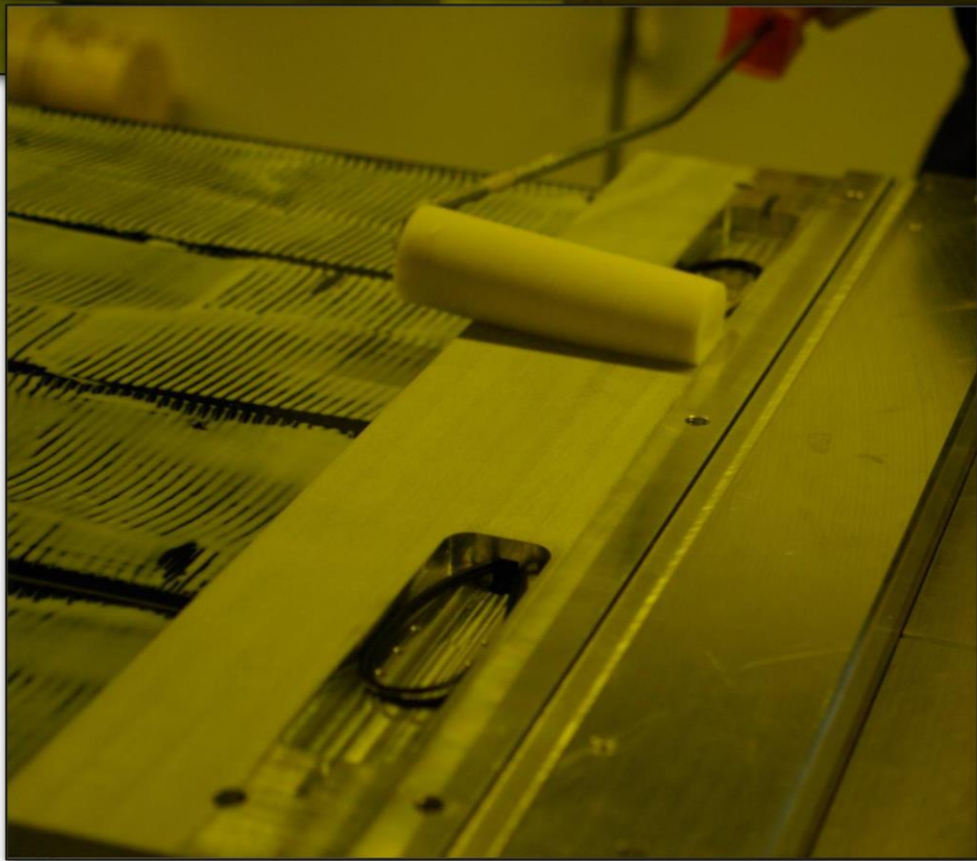
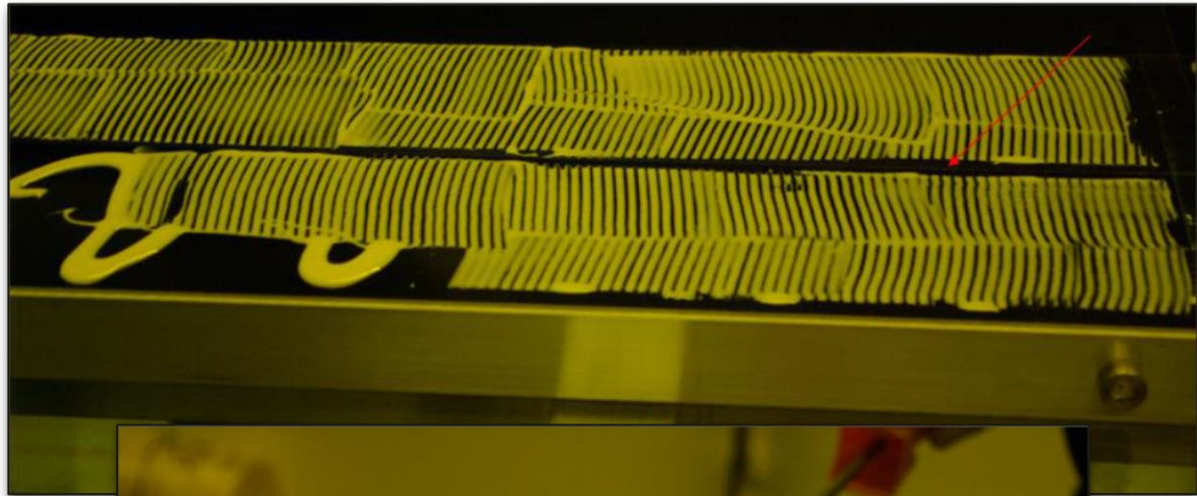

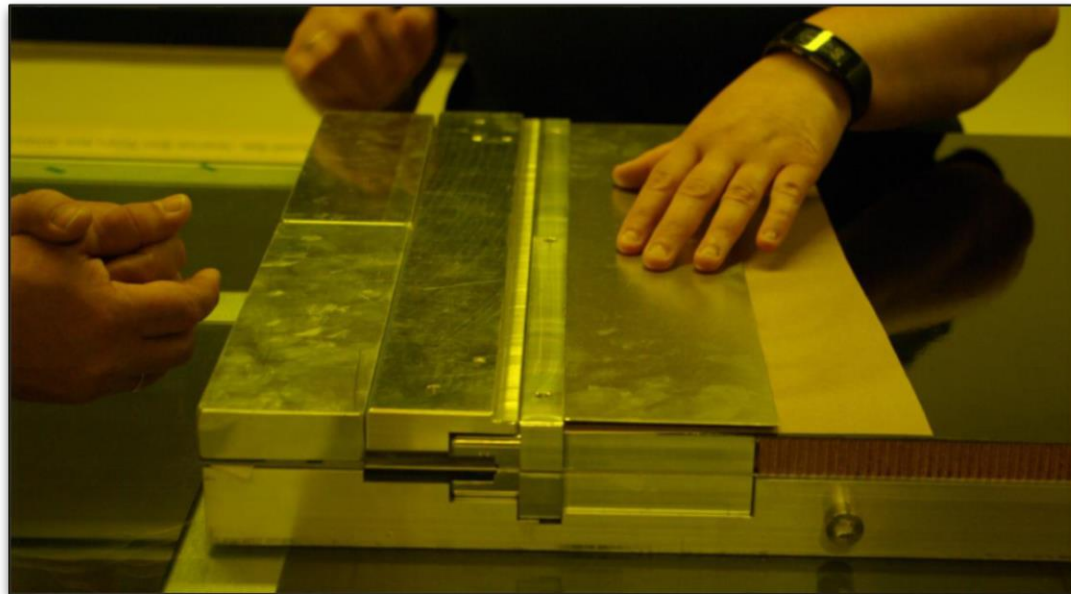
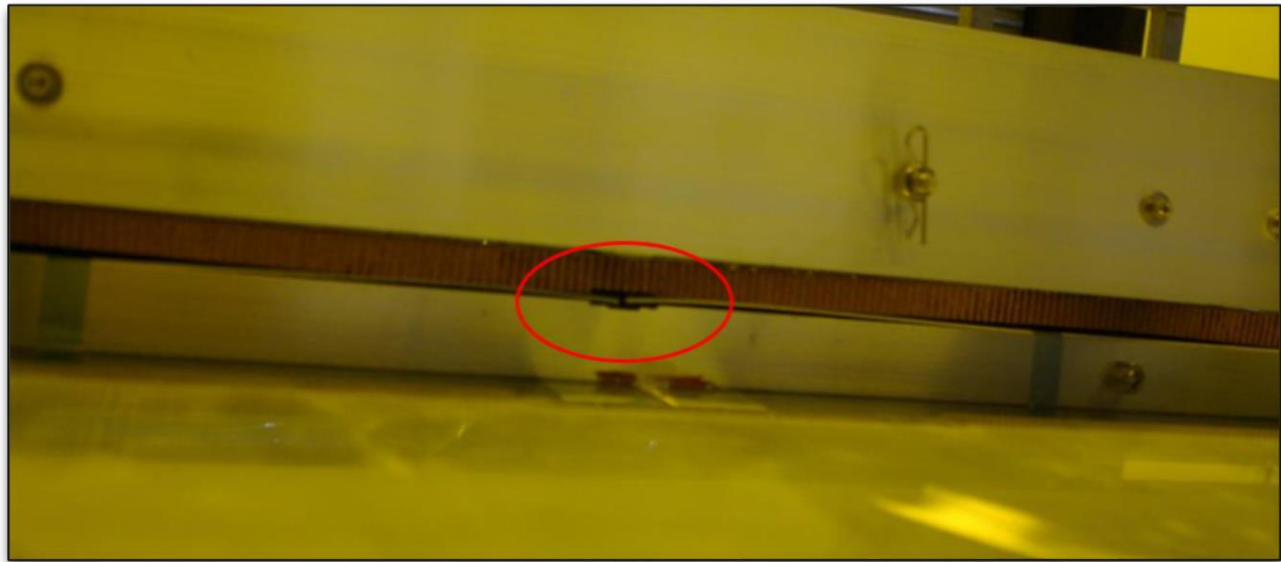

APPLY VACUUM



2ND GLUING STEP: PANEL 2

Remove vacuum hood

Remove “bridges”

Remove Module from Gluing Jig with lifting and turning device and place it on the Gluing and alignment Jig for the second gluing step

Align Module with “bridges” and block position

Remove “bridges”

Repeat glue application of 1st gluing step for panel only

2ND GLUING STEP

Remove from 1st template

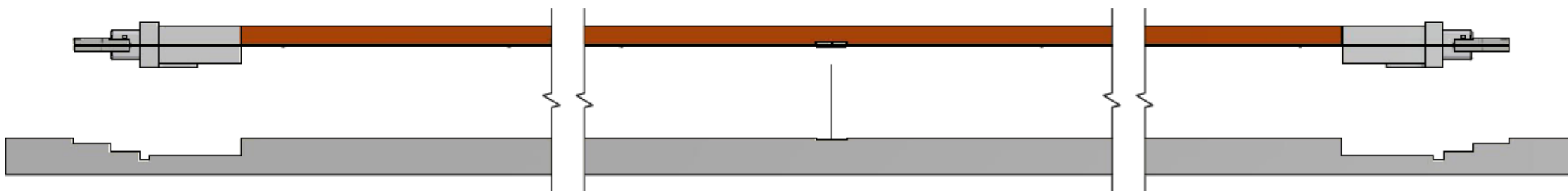

Add the 2nd panel

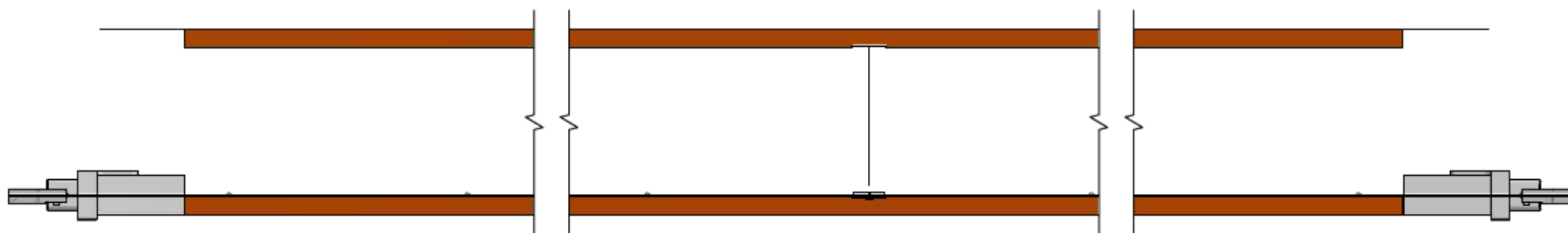

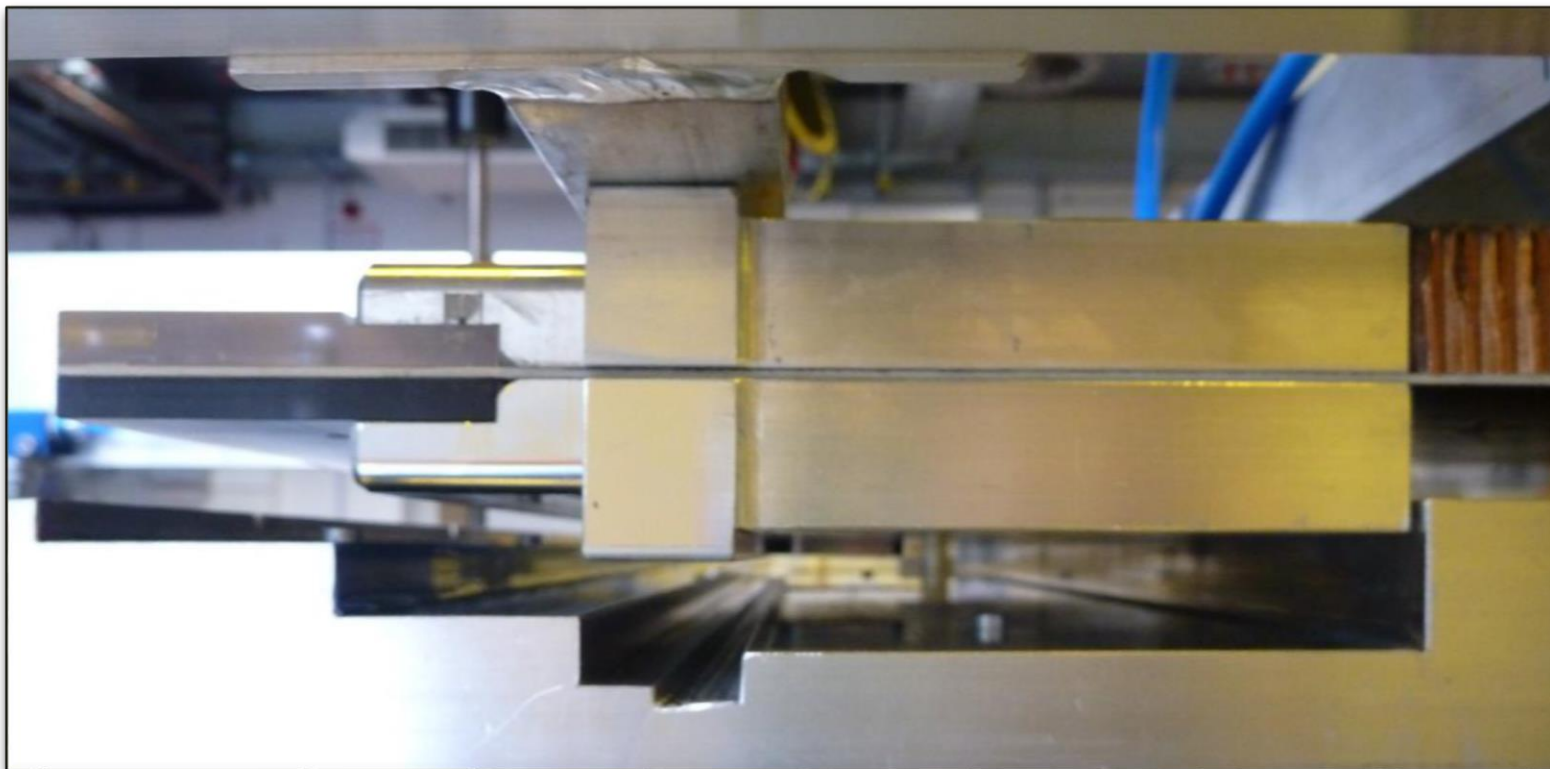

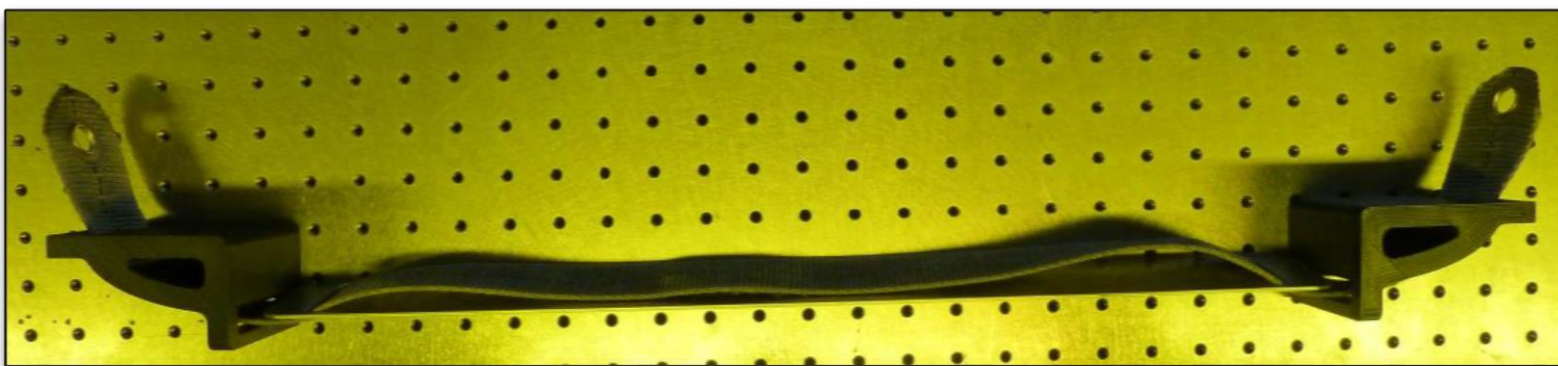



SLIDE TO THE 2ND TEMPLATE

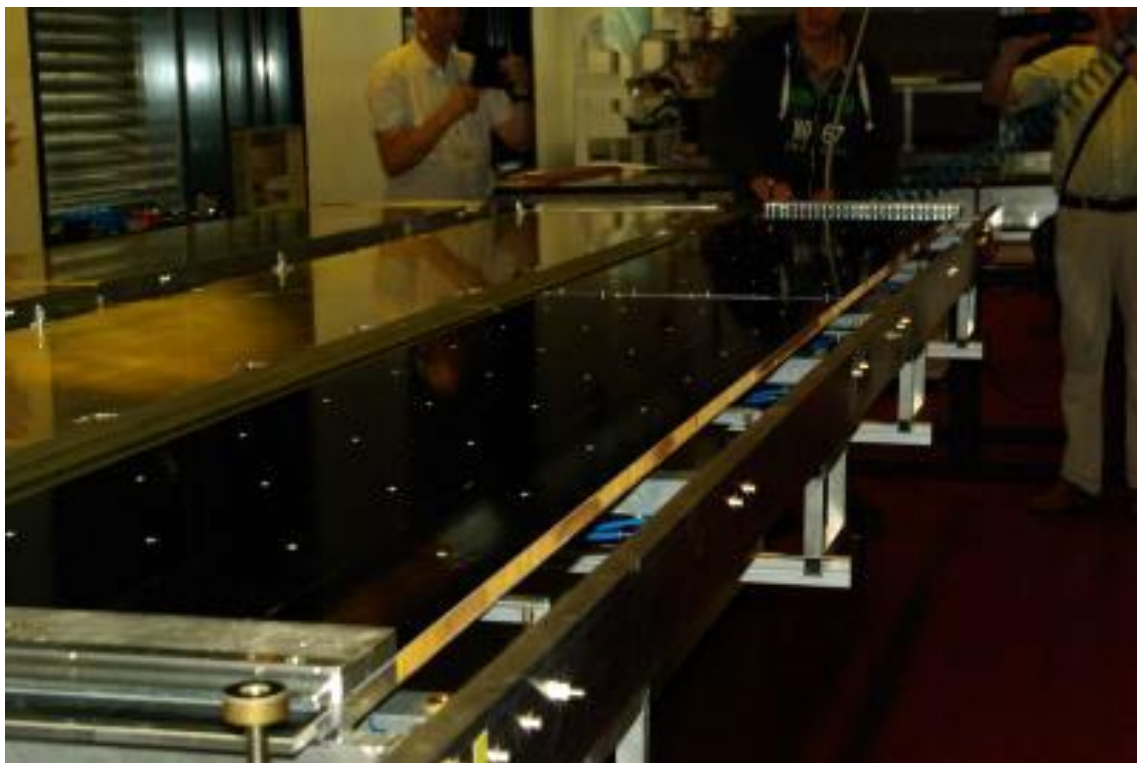



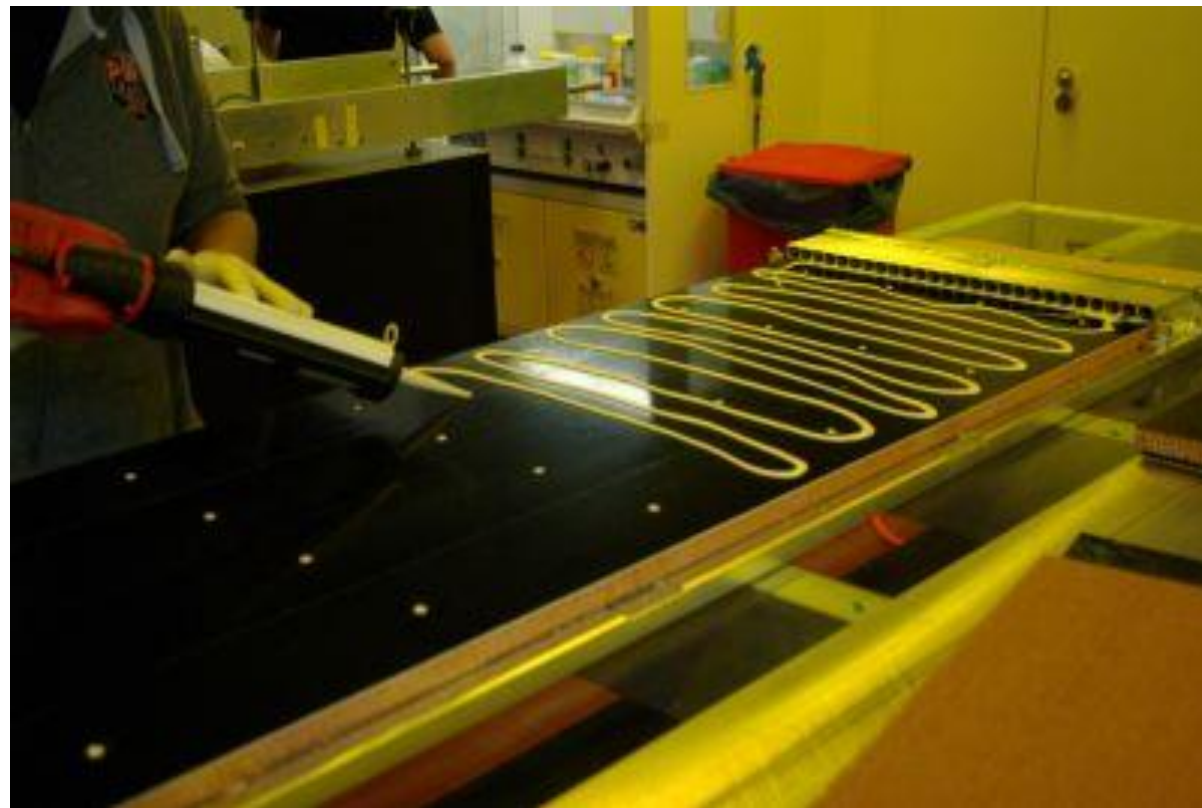
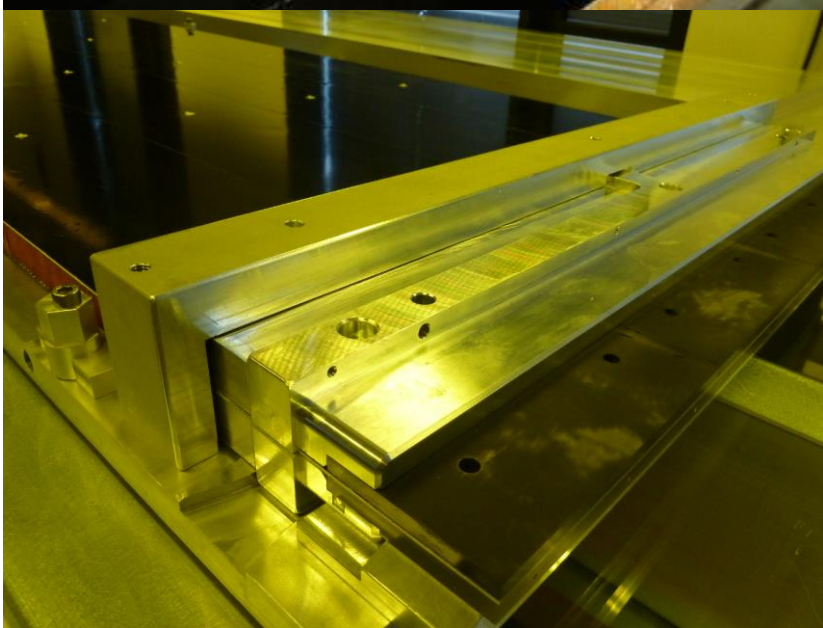
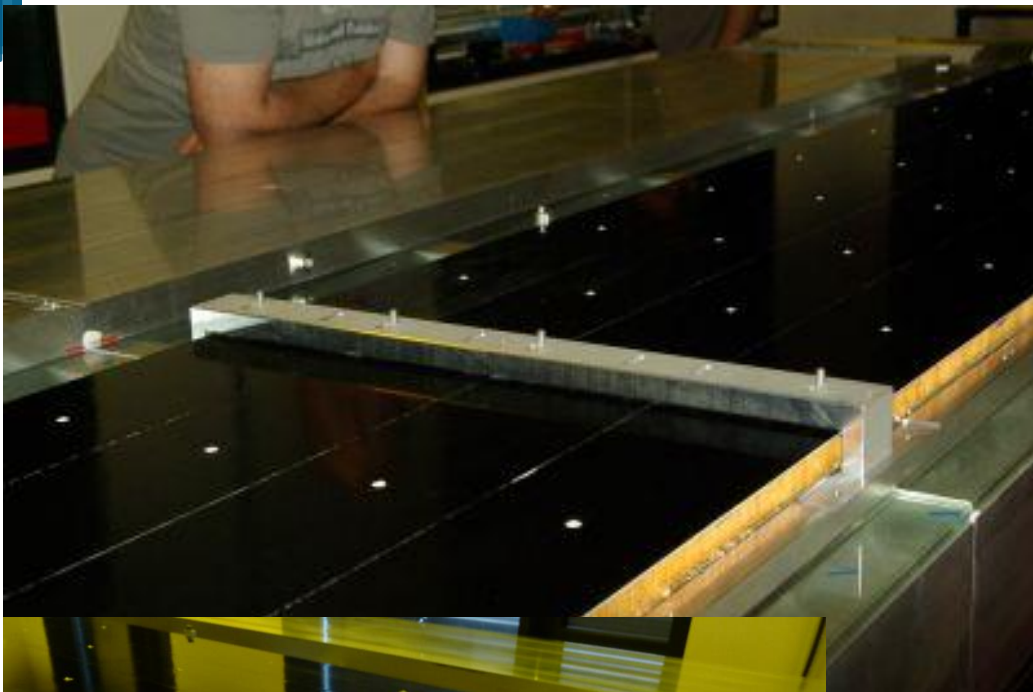

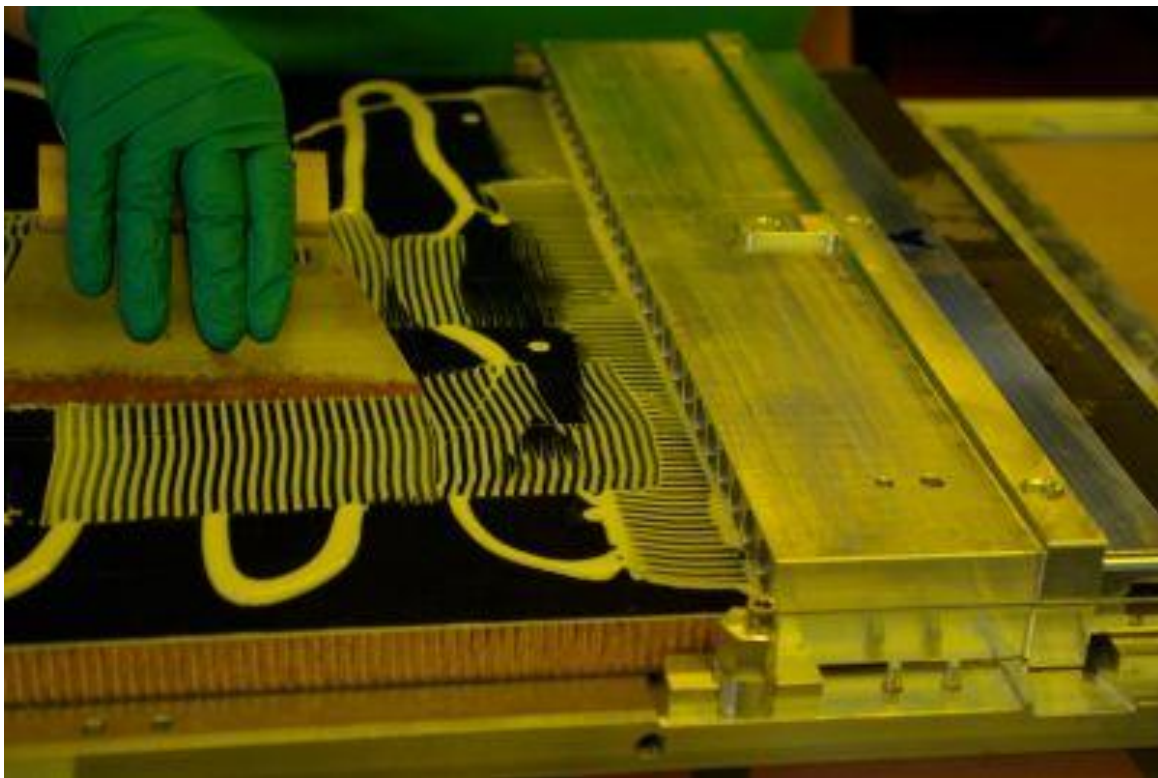

ADD 2ND PANEL

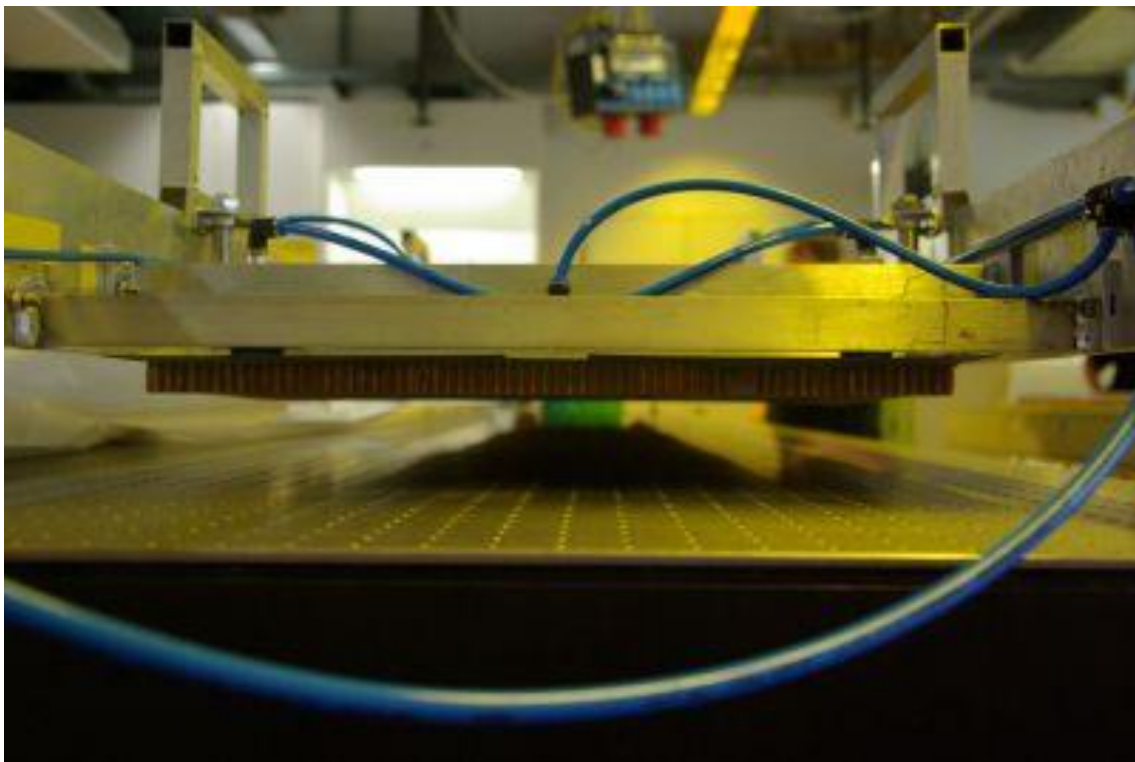

PRESS AGAIN

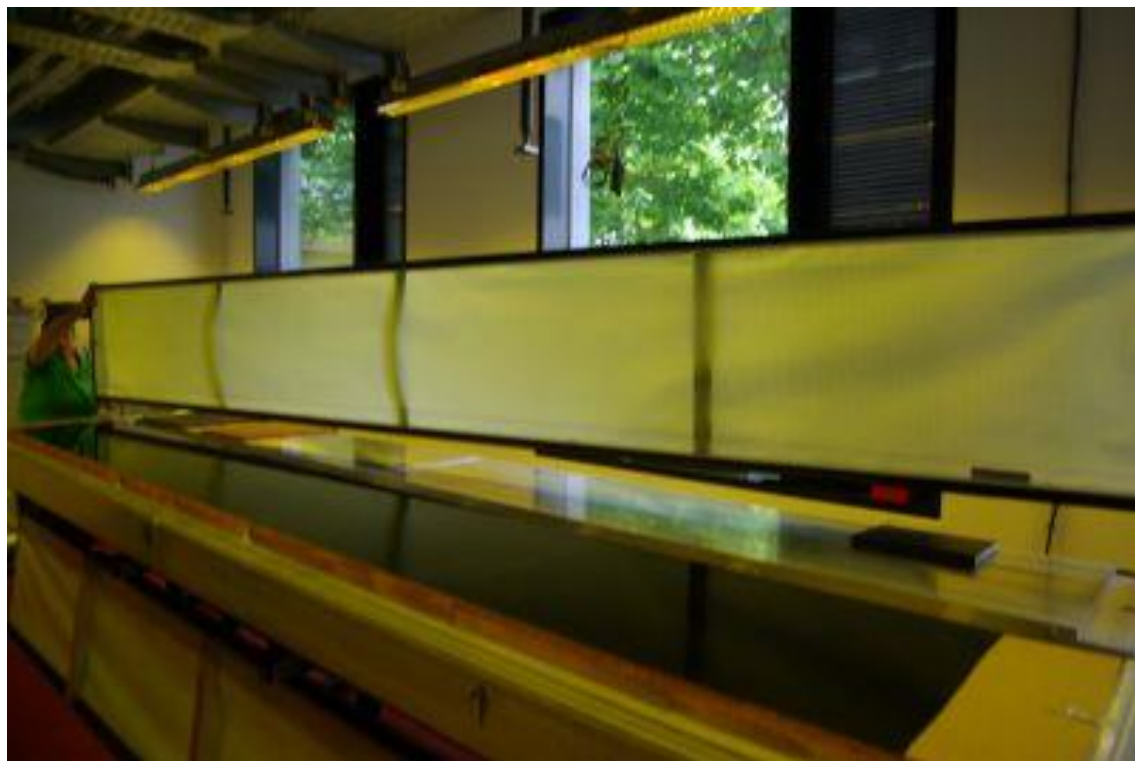

3RD GLUING STEP: SIDEWALL AND FLANGE GLUING

Time 0,75 hours

FTE: 2/1 (2 for sidewalls, 1 for cold-box flange)

Parts

- Coldbox flanges
- Dowel pins (2 x Zylinderstift ISO 8734 - 5x14 - A -St)
- Screws (8 x Zylinderschraube ISO 4762 - M3x14)
- U-profiles
- Light tight sealer (black silicone)
- Araldit AW116 (XX gr)
- syringe with ØXY tip
- kapton tape
- PVC sheet as distance holder (thickness 4mm)

3RD GLUING STEP: SIDEWALL AND FLANGE GLUING

Preparation

- Put module on the PVC sheets
- Rough approx.. 20mm wide surface at the edges of the panels on both edges and both sides.
- Clean dust from panels, endplugs and cold-box flanges
- Clean panels, endplugs and cold-box flanges with isopropanol

Gluing of coldbox flange

- Apply glue/sealer between both endplugs until the sealing surface for the coldbox flange.
- Apply glue/sealer on sealing surface for the cold-box flange.
- Place dowel pins into the endplugs
- Put cold-box flanges onto endplugs
- Screw flange to the endplugs
- Clean residues of glue/sealer

3RD GLUING STEP: SIDEWALL AND FLANGE GLUING

Gluing of U-profiles

- Place U-profiles on the module. U-profile has to go until the collar at the endplug.
- Apply glue Araldit 116 with a syringe between profiles and the panels on one side
- To avoid glue sticking out fix put kapton tape all along the junction of profiles to panels
- Turn the module with Lifting and Turning device
- Repeat the procedure of gluing for the other side.
- Ensure that the glued surface underneath is lying on the PVC sheets and put weight (XYkg over 5m...?) on glued surface.
- Curing time 12 h

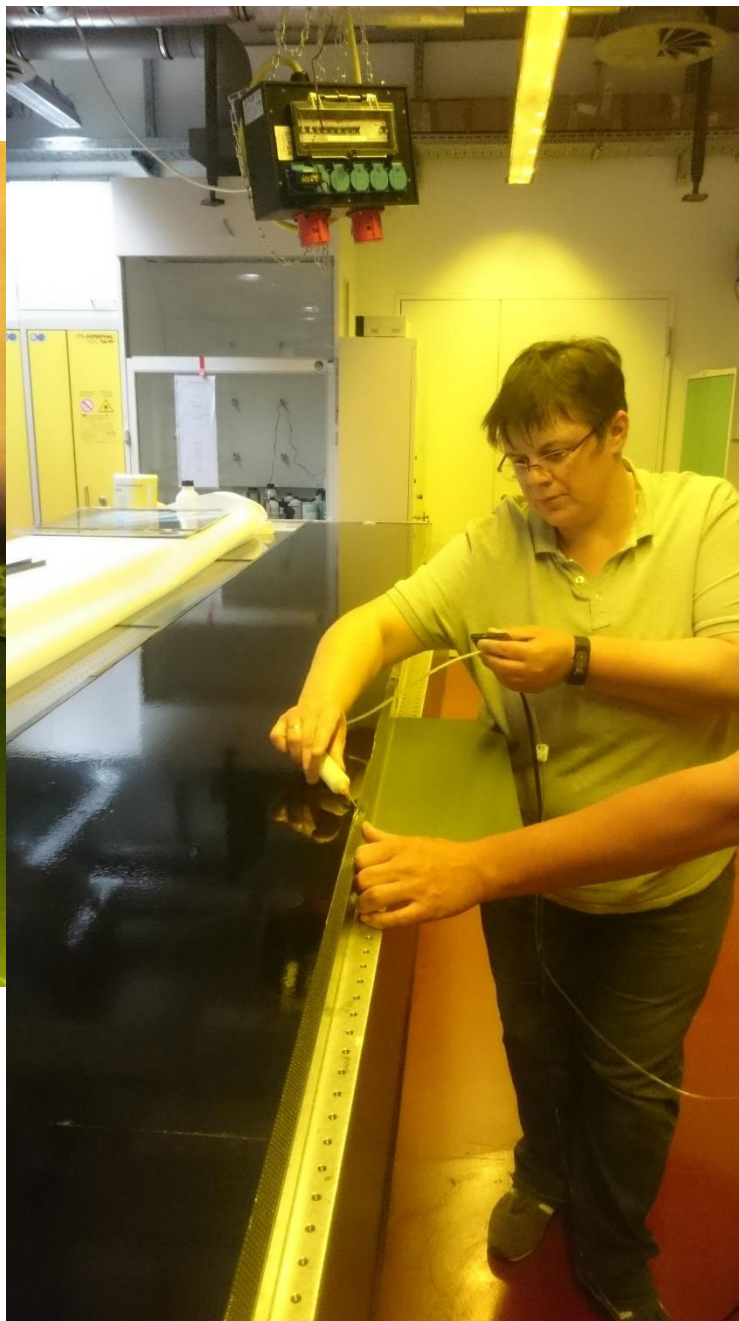
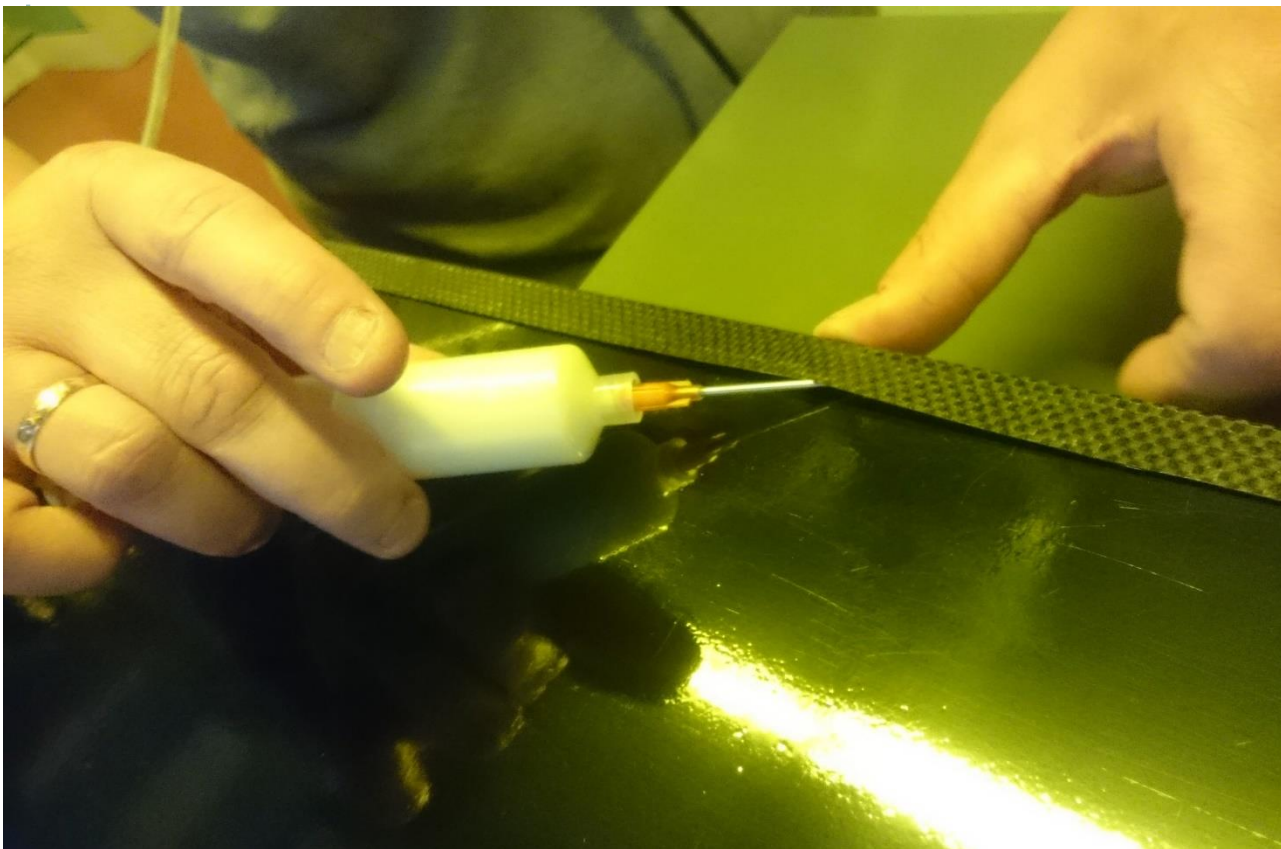

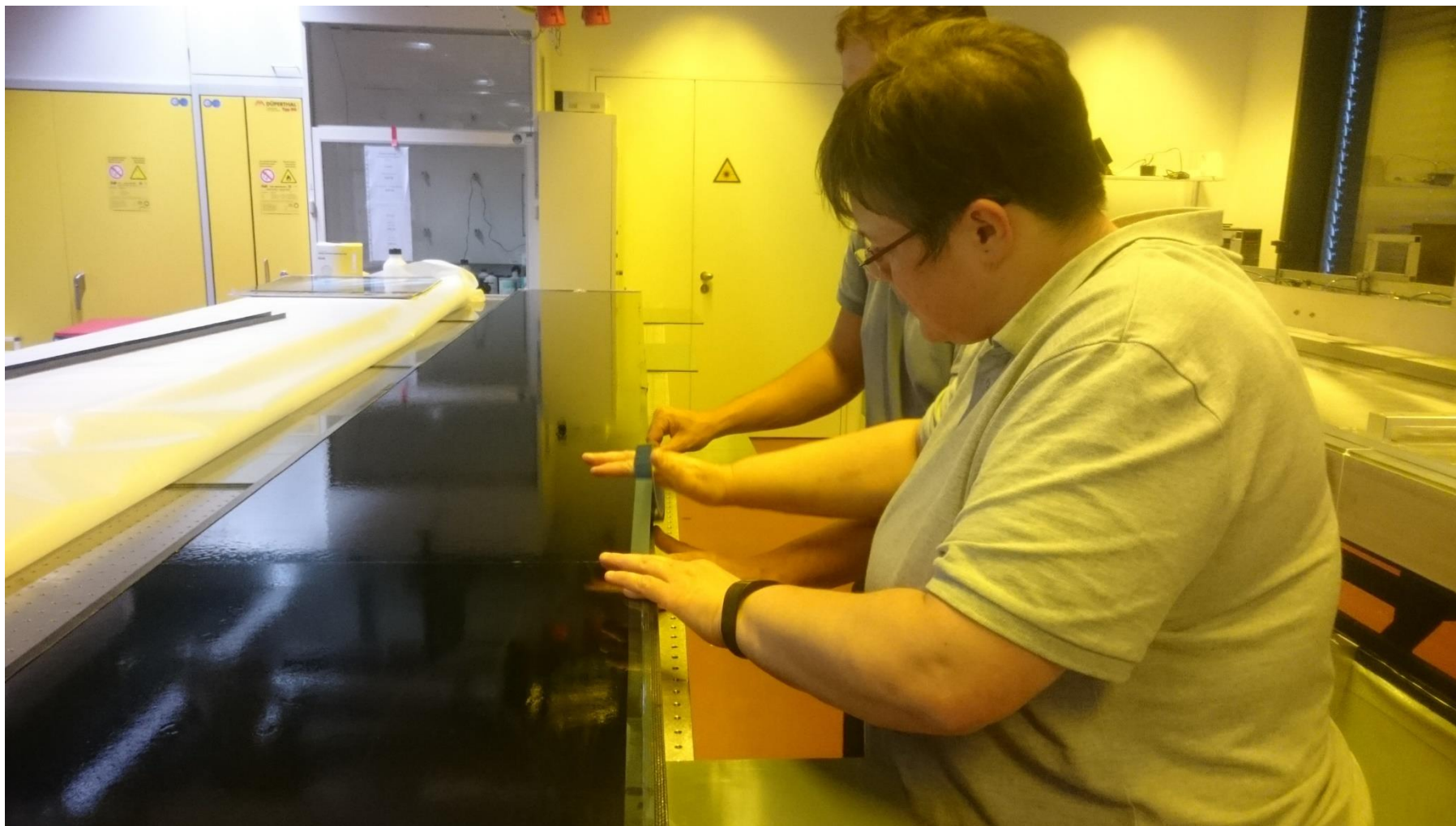

TRANSPORTATION AND STORAGE

CRATES AND STORAGE

3 modules per box (weight reasons)

- 20 kg / module

Stored in vertical positions

Enclosed in sealed plastics bags

Crates kept in a (refrigerated)
shipping container in the assembly
hall

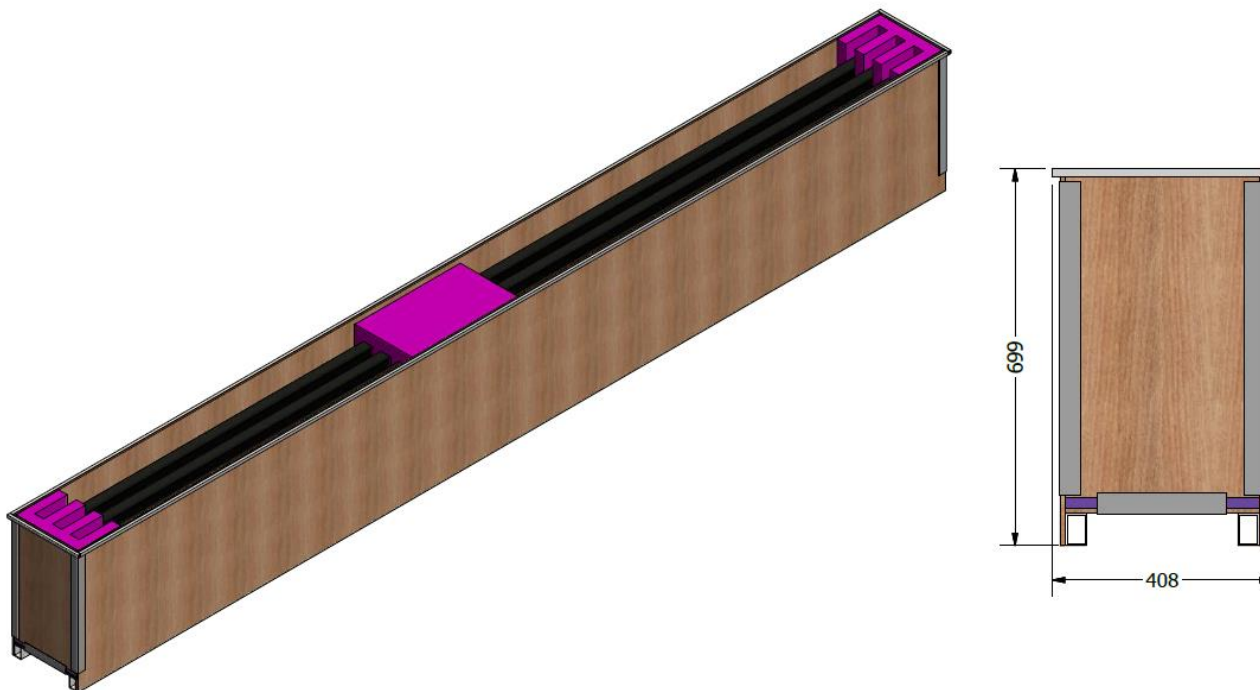

FIRE SAFETY

The scintillating fibres are flammable, **and will drip burning plastic**. Not allowed under IS41 at CERN.

Risk mitigation:

Cover the fibres in self-extinguishing materials

- Nomex honeycomb is rated for aircraft interiors and self-extinguishing
- CFRP epoxy must be chosen correctly
- Polyimide foil (i.e. Kapton) is self-extinguishing

Samples for burn tests by external company (t.b.d.) with current materials

