

Crab cavity prototype test: operational scenarios and optics

Riccardo de Maria (BNL),
R. Calaga (BNL), Y. Sun(CERN), R. Tomas(CERN)
Acknowledgments to O. Bruening, S. Fartoukh, M.
Giovannozzi, G. Kotzian, W. Hoefle, J. Tuckmantel, F.
Zimmermann.

September 16, 2009

Motivation

Layout and optics

Luminosity

Future work

Motivation

The crab cavity prototype test (phase I) has the following goals/milestones:

- ▶ Show that crab cavities can be installed and operated safely in the LHC.
- ▶ Find measurable proofs of a beneficial effect of the cavity on the luminosity.
- ▶ Test luminosity leveling.

The prototype test does not specifically aim at exceeding the LHC peak luminosity performance and doesn't aim at using the crab cavity during normal operation (see Phase II for crab cavities).

LHC

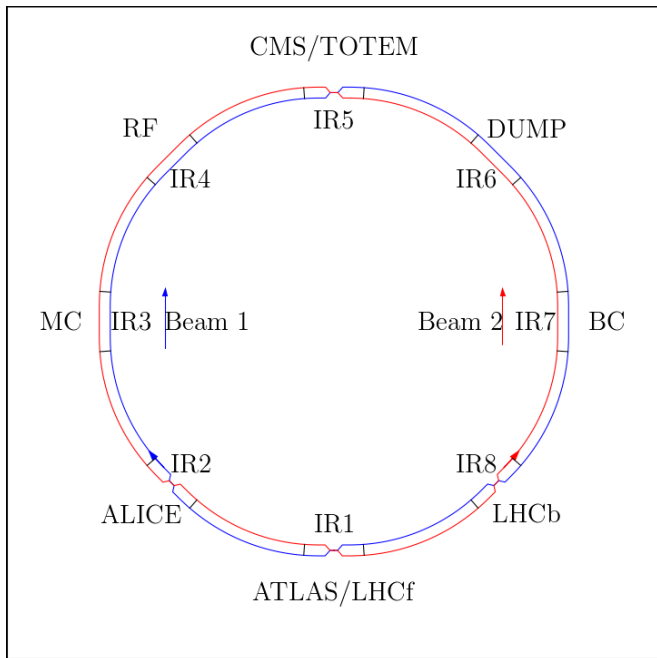

IR4 dogleg layout

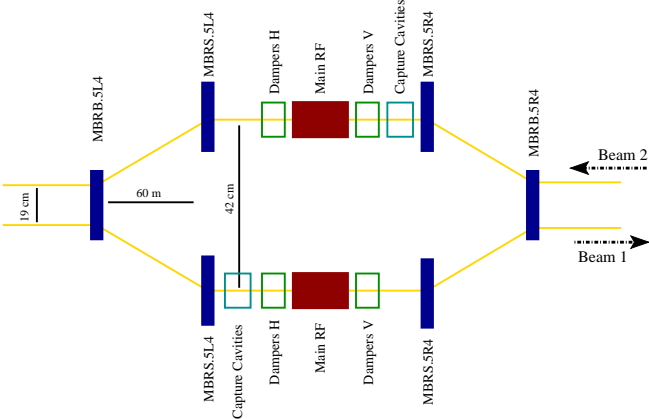

Crab cavity test integration layout

We propose a global scheme.

The details of the cavity cryomodules are not known at this time.

We assume that:

- ▶ the crab cavity assemblies will fit both transversely and longitudinally in the capture cavities reserved slots and occupy their place during the period of the test,
- ▶ there will be 2 cryo modules, one per beam, installed left and right w.r.t. IP4 for Beam 1 and Beam 2 respectively.

Details on integration issue will be given by Olivier.

Sketch of the operations

The prototype test will use at the beginning few bunches and only after success the nominal intensity beam.

- ▶ Injection and ramp: the cavity should be transparent
 - ▶ 0-kick: RF loops on to maintain 0 energy in the cavity (possible in case of a cryo failure?)
 - ▶ detuned: the beam does not see it (5kHz is enough?)
 - ▶ dephased: the cavity act like a dipole kicker (watch out for distortion!)
- ▶ Collision: the cavity should show its effect.
 - ▶ ramp: few tens of turns fulfill adiabaticity (see Yipeng)
 - ▶ measure luminosity improvements
 - ▶ test luminosity leveling

More details will be given by Stefano.

During collisions we would like to make an efficient use of the cavity voltage...

Crab Voltage

The effect of the crab cavity depends on RF voltage and phase and the optics parameter of the machine.

We define V_{full} to be the voltage needed by one cavity to rotate each bunch of half crossing angle ($\theta_c/2$), that is:

fully compensate the geometric reduction if there is one crab cavity per beam.

The cavities for the test may or may not reach this voltage.

$$\frac{\theta_c}{2} = \frac{V_{\text{full}} \omega_{\text{rf}} \sqrt{\beta_{\text{crab}} \beta^*} \cos(2\pi(\psi_{\text{cc} \rightarrow \text{ip}}^x - \mu_x/2))}{2cE_0 \sin(2\pi\mu_x/2)}$$

From the optics point of view the relevant quantities are:

the β function at the location of the cavity β_{crab} and the collision point β^* and

the phase advance between them $\psi_{\text{cc} \rightarrow \text{ip}}^x = |\psi_x(s_{\text{ip}}) - \psi_x(s_{\text{cc}})|$.

The other quantities are: E_0 , beam energy; $\theta_c = d_{\text{sep}} \sqrt{\varepsilon/\beta^*}$, the crossing angle; ω_{rf} , the crab cavity RF frequency;

μ_x is the horiz.tune.

β_{crab} and $\psi_{\text{cc} \rightarrow \text{ip}}^x$ can be optimized.

Nominal Phase 1 optics data

Assuming $\mu_x = 63.31$ (integer part does not matter): for max effect, ideal $\psi_{cc \rightarrow ip}^x \bmod 1$ is .655 or .155.

For min effect (e.g. IP1), ideal $\psi_{cc \rightarrow ip}^x \bmod 1$ is 0.405 or 0.905.

In the nominal case, for Beam 1 and Beam 2 respectively, we have:

$\psi_{cc \rightarrow ip5}^x = 7.687, 8.157$, very close to the optimum;

$\beta_{crab} = 204\text{m}, 260\text{m}$, small values compared to what we would need.

Beta values are restricted by the normal aperture constraints at injection.

Higher value could be reached at higher energy because the beam size scales linearly with the energy. The crab cavities do not impose any aperture constraint.

Nominal Phase I optics Beam 1

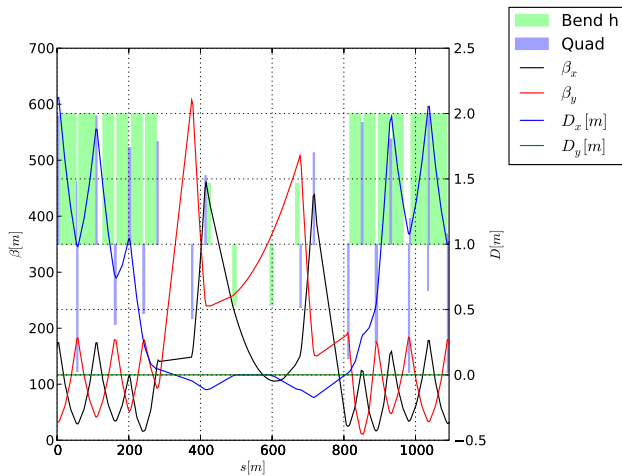

Nominal Phase I optics Beam 2

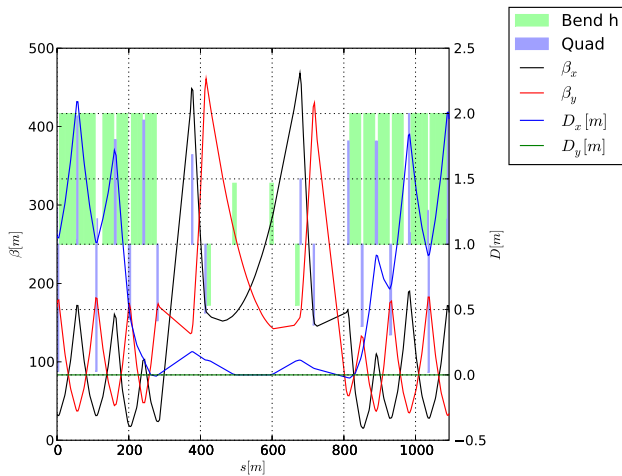

Aperture constraint for Beam 1

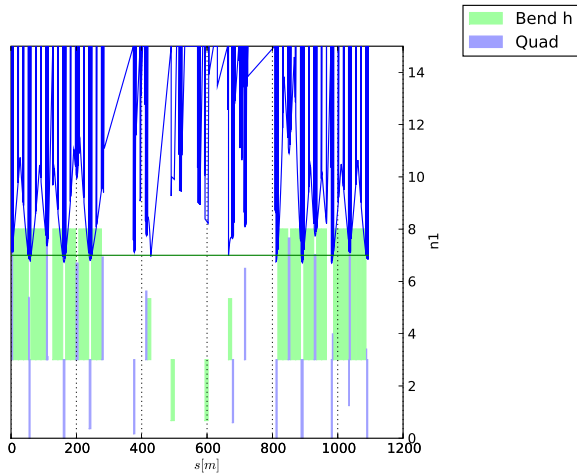

Aperture constraint for Beam 2

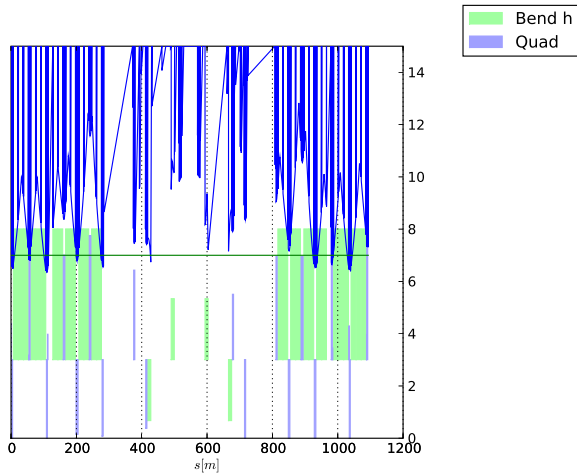

IR4 un-squeeze for crab cavity operation

In order to use efficiently the cavity voltage, we need the largest possible beta function and the right phase advance between the IPs.

We propose to perform an un-squeeze similar to the way the beta function is squeezed in the IP1 and IP5 to reduce the beam size.

The un-squeeze is designed to start at 7TeV and reach the maximum beta function at the crab cavity location. The total phase advance of the insertion is kept constant.

It is possible to start at lower flat top energy: the peak beta function will be necessarily reduced, but the optics will gain tunability by the gradients reserve not available at 7TeV.

Transition optics

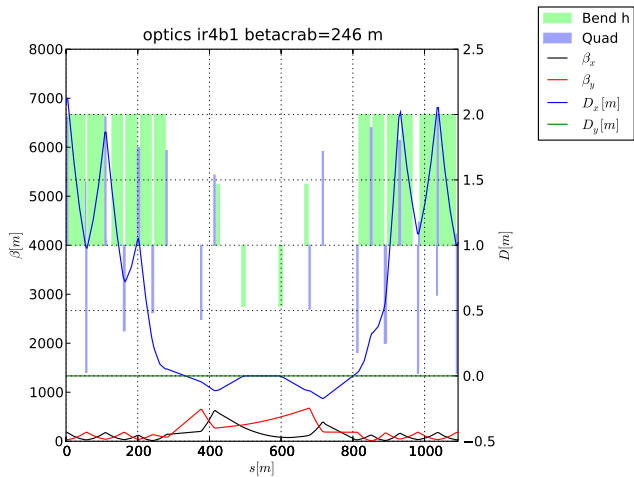

Transition optics

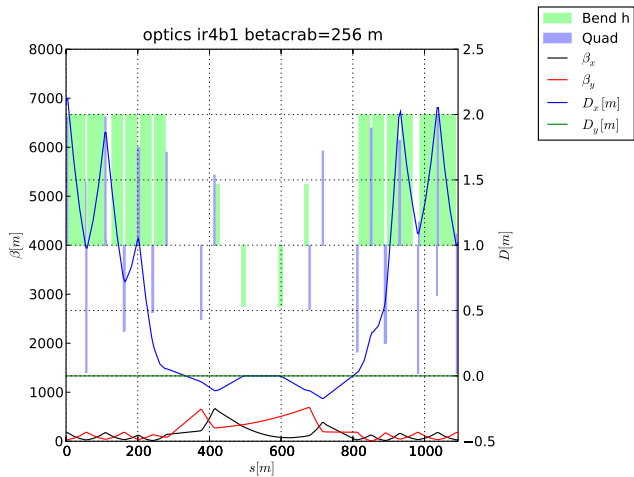

Transition optics

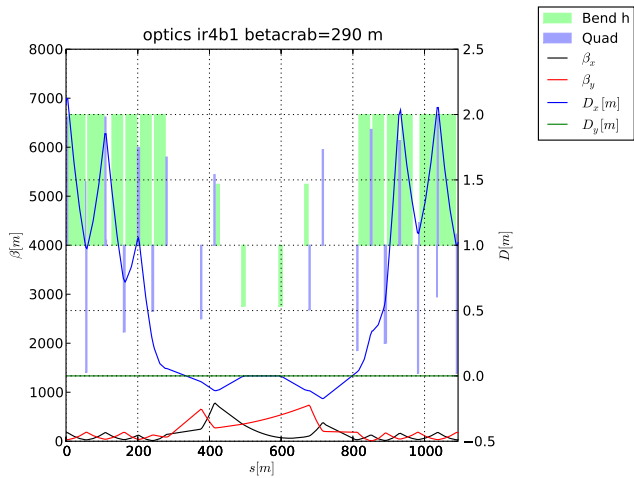

Transition optics

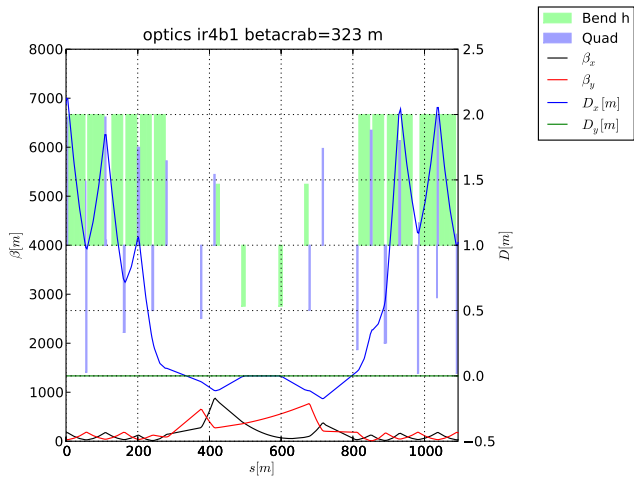

Transition optics

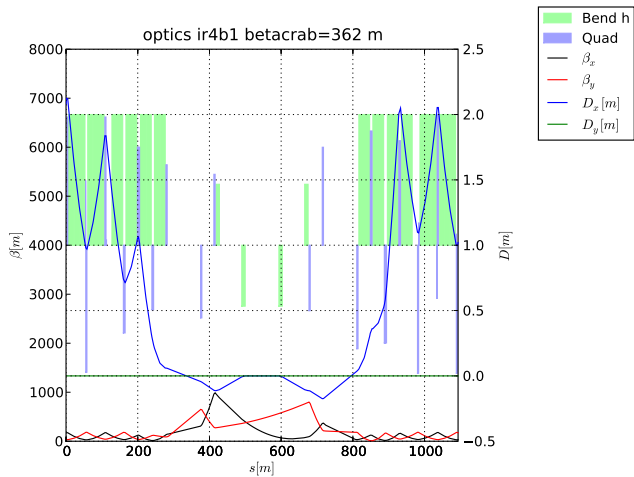

Transition optics

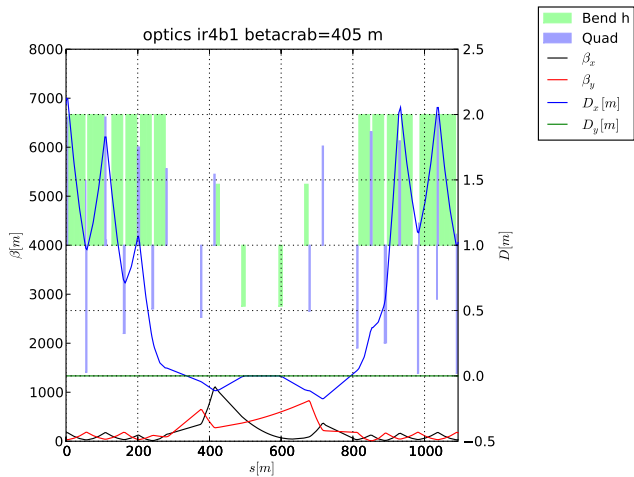

Transition optics

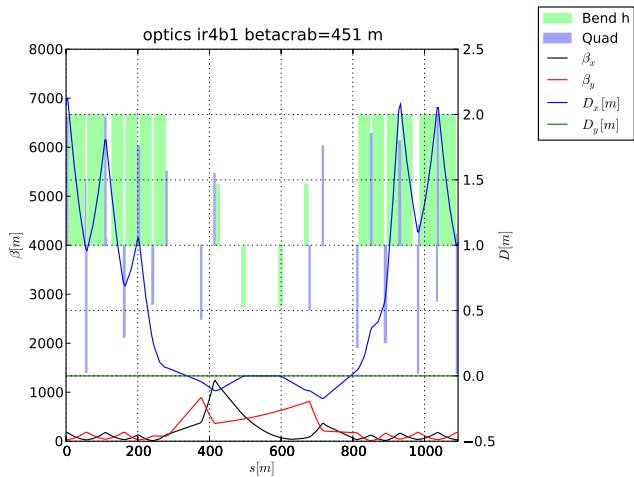

Transition optics

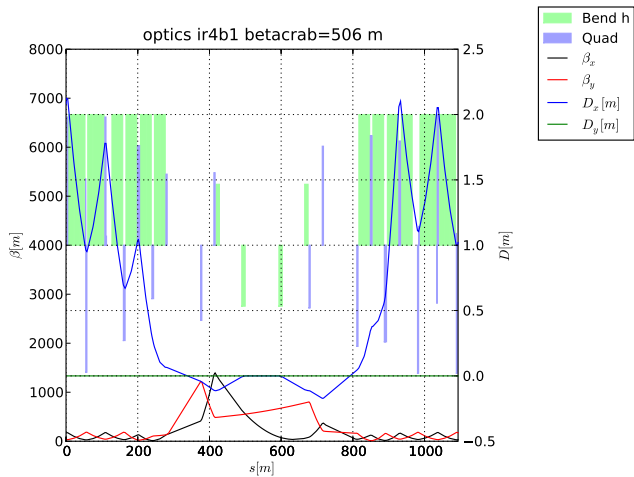

Transition optics

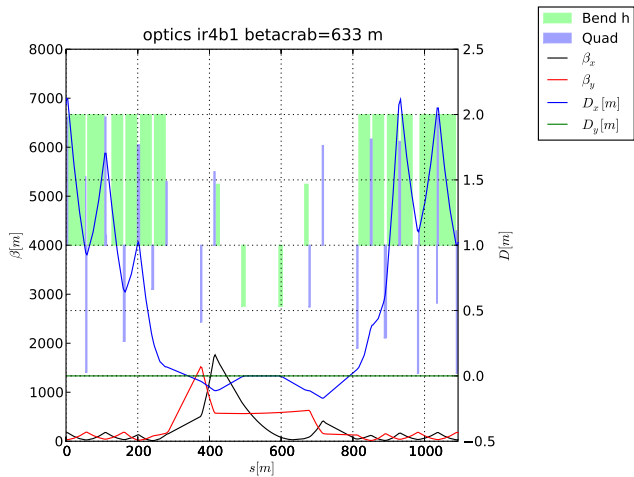

Transition optics

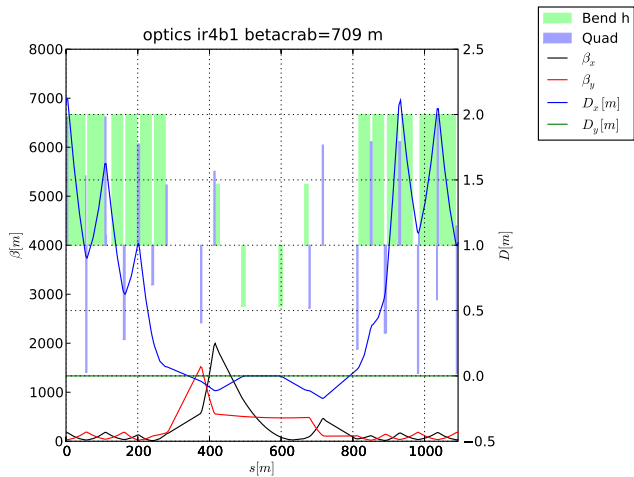

Transition optics

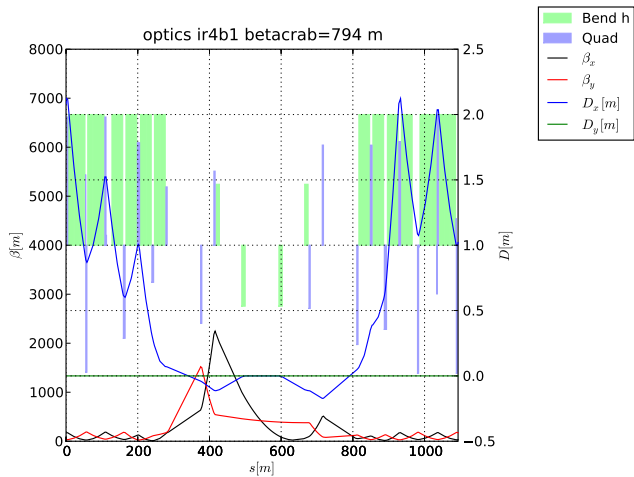

Transition optics

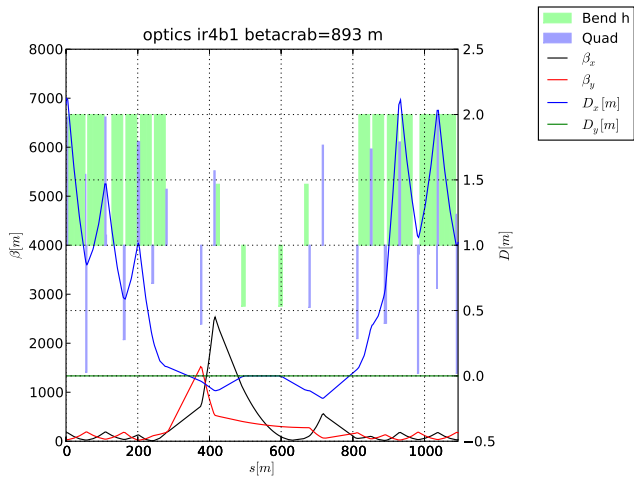

Transition optics

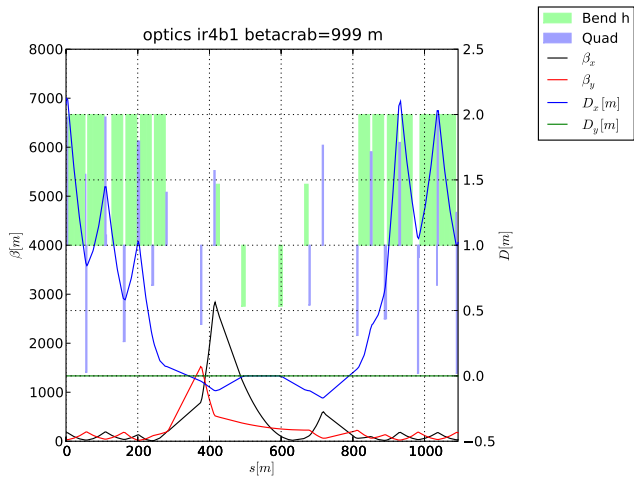

Transition optics

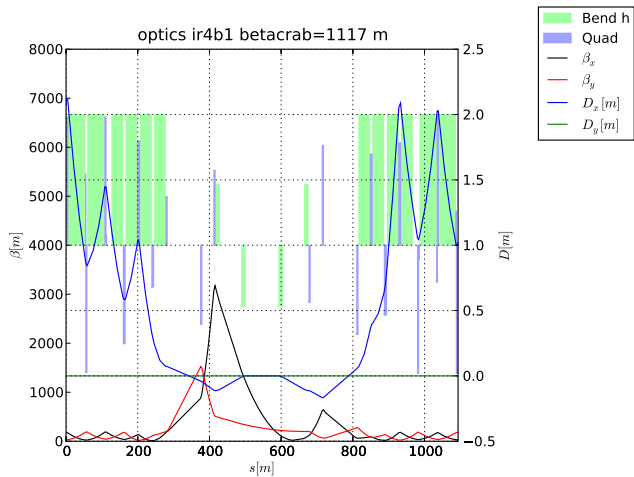

Transition optics

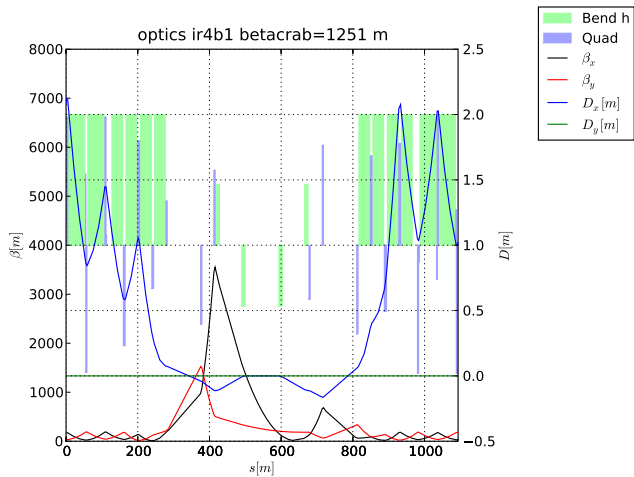

Transition optics

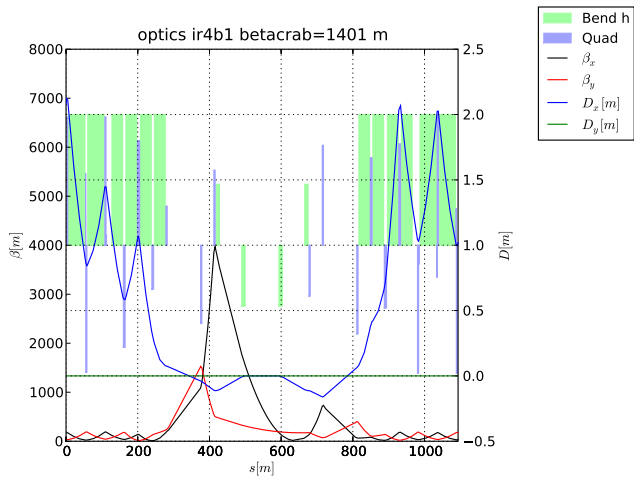

Transition optics

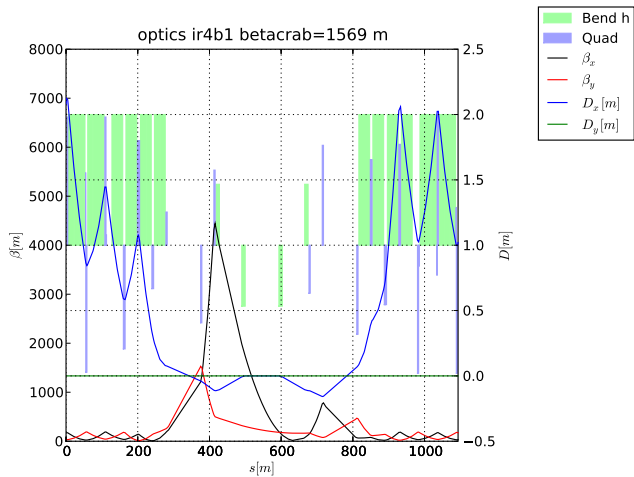

Transition optics

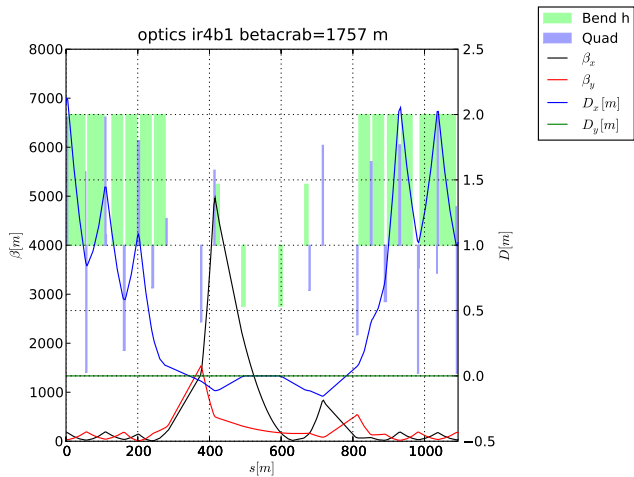

Transition optics

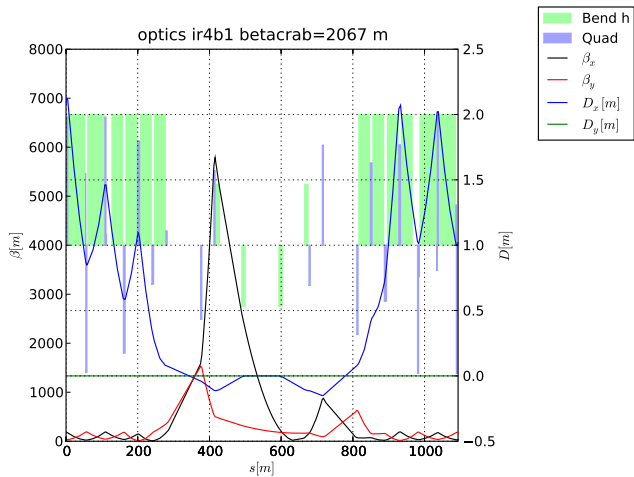

Transition optics

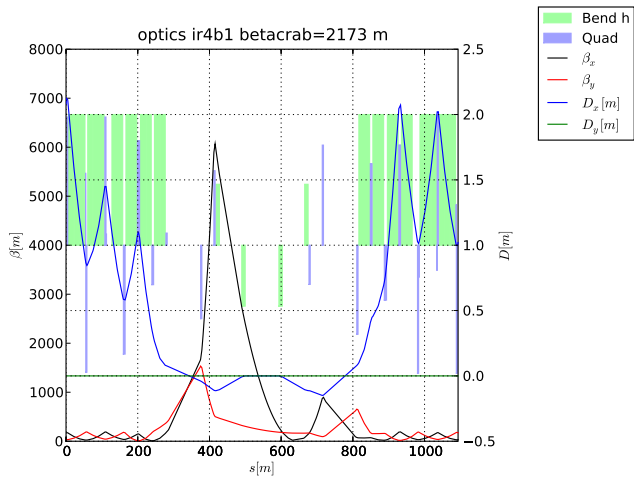

Transition optics

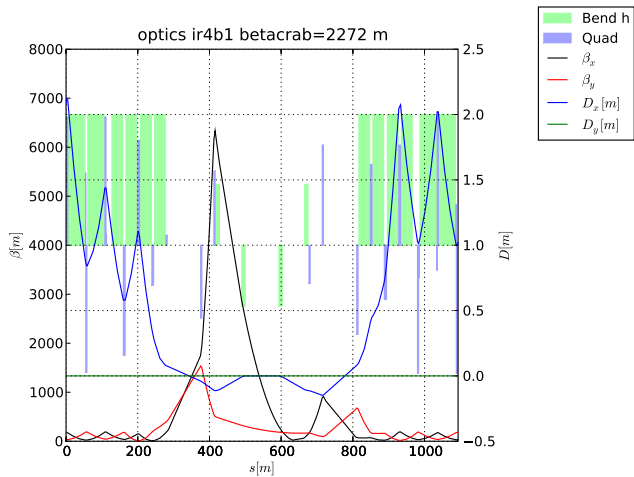

Transition optics

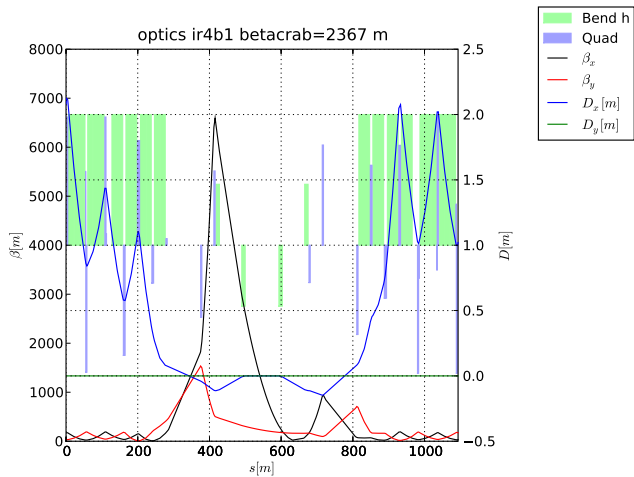

Transition optics

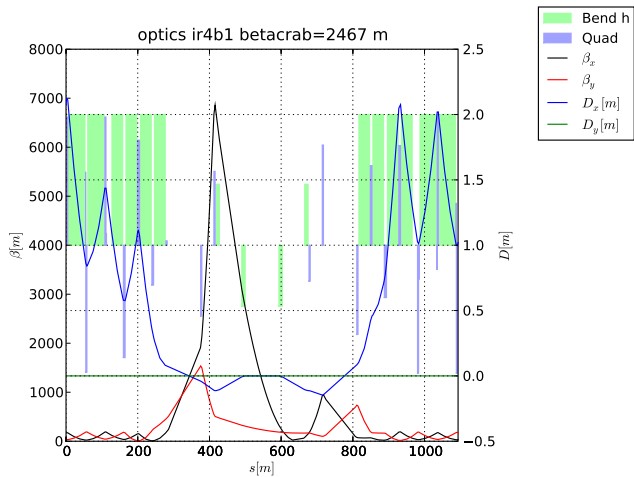

Transition optics

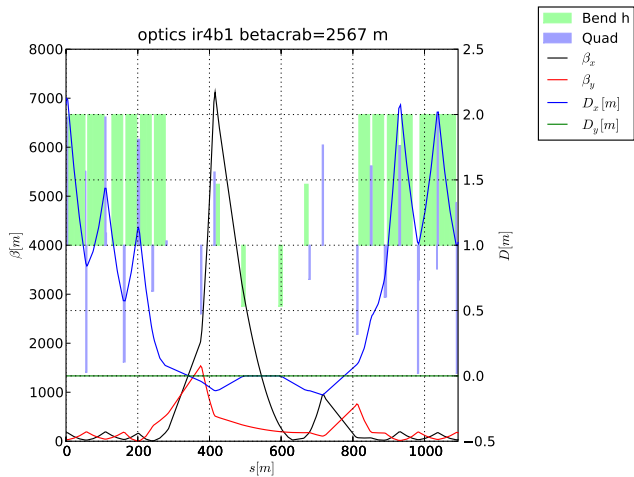

Transition optics

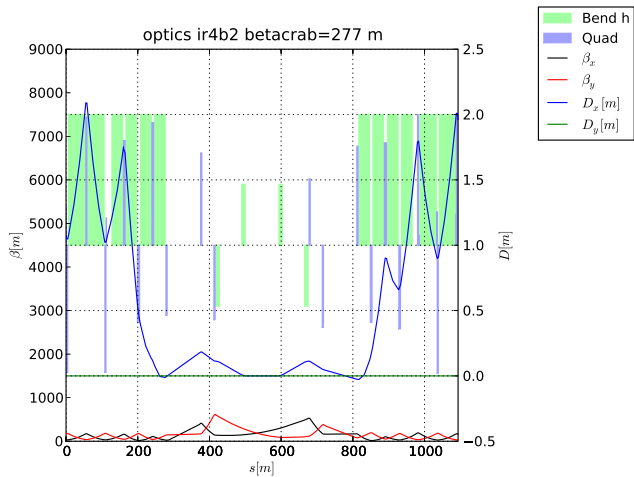

Transition optics

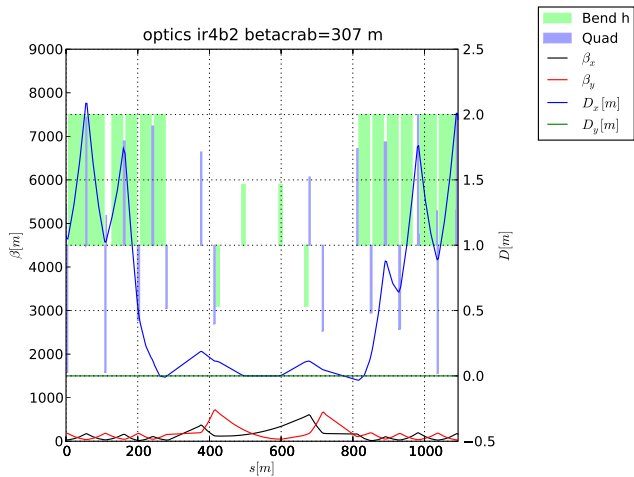

Transition optics

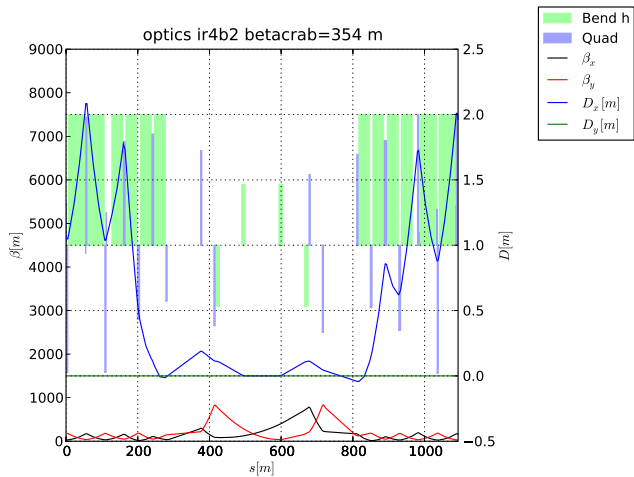

Transition optics

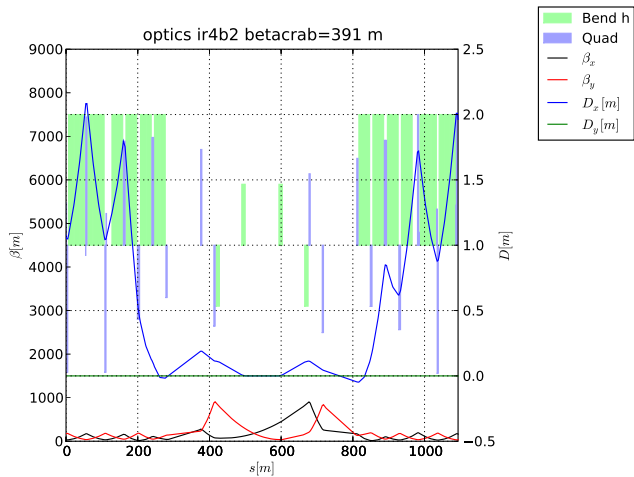

Transition optics

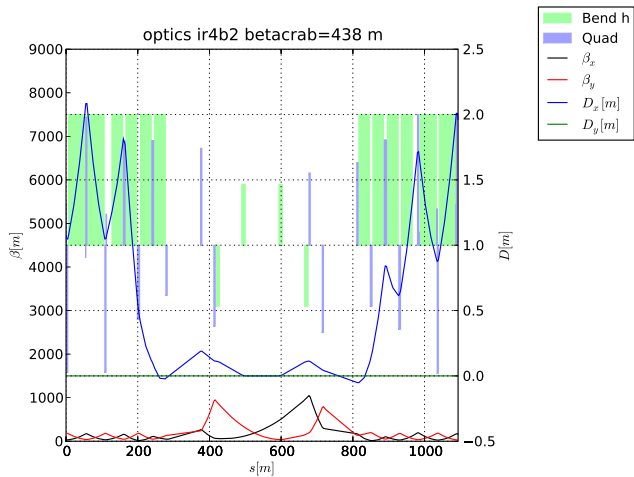

Transition optics

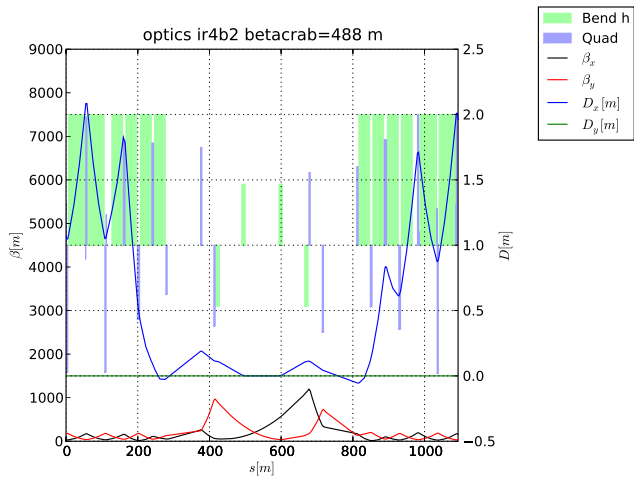

Transition optics

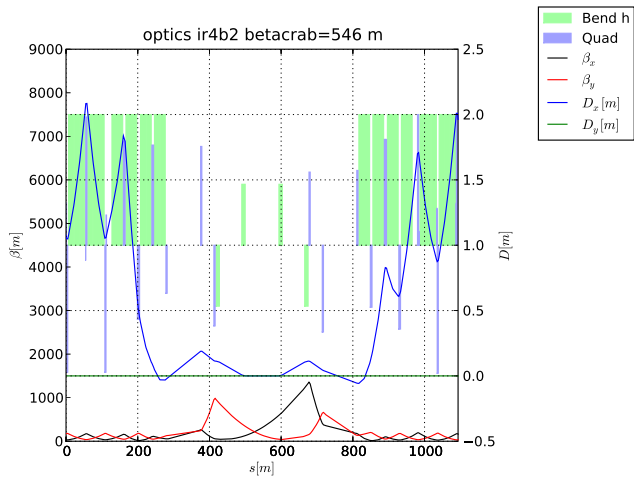

Transition optics

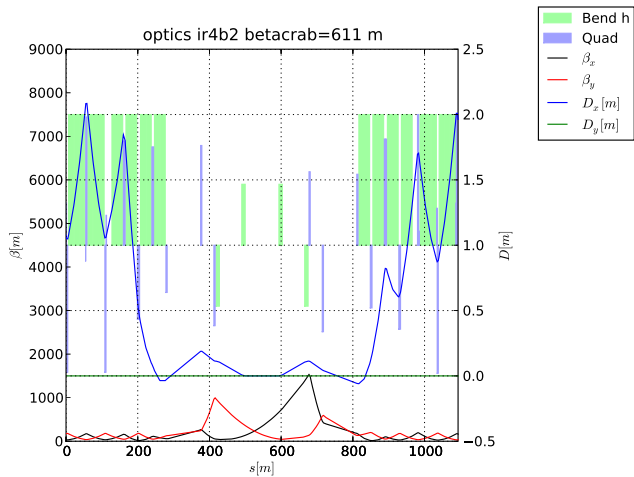

Transition optics

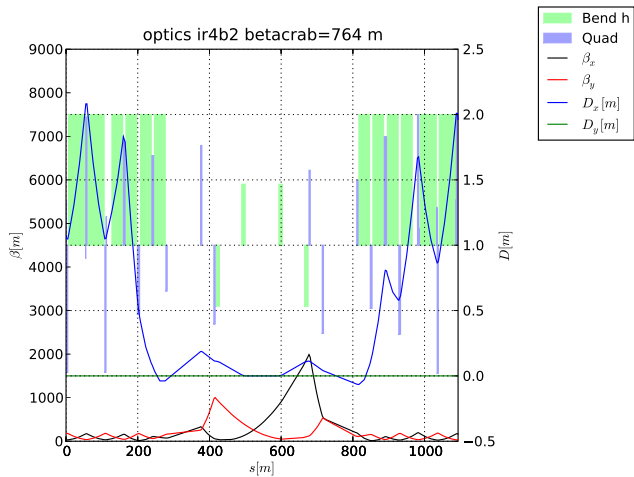

Transition optics

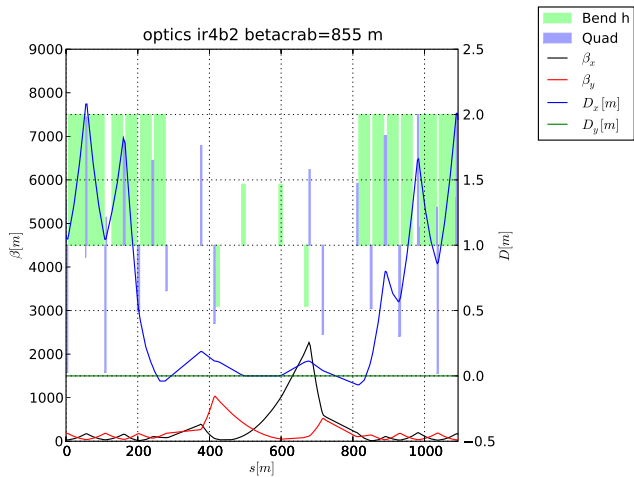

Transition optics

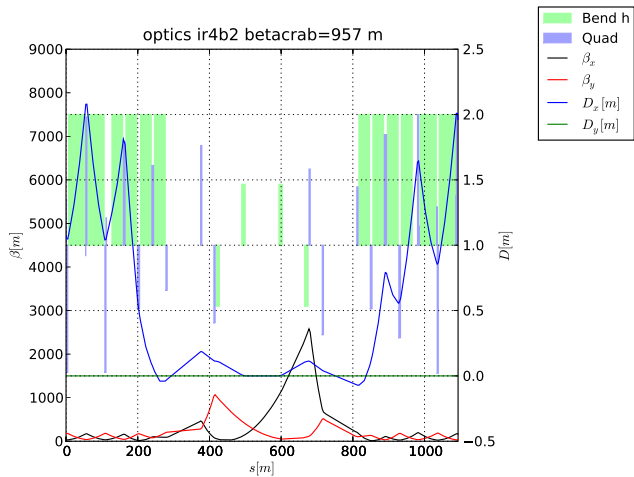

Transition optics

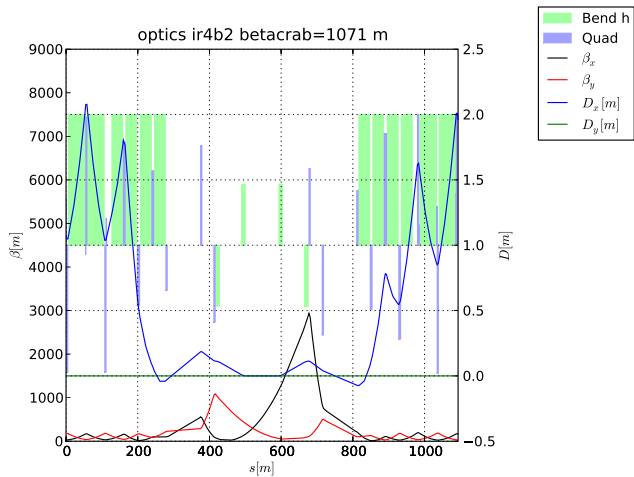

Transition optics

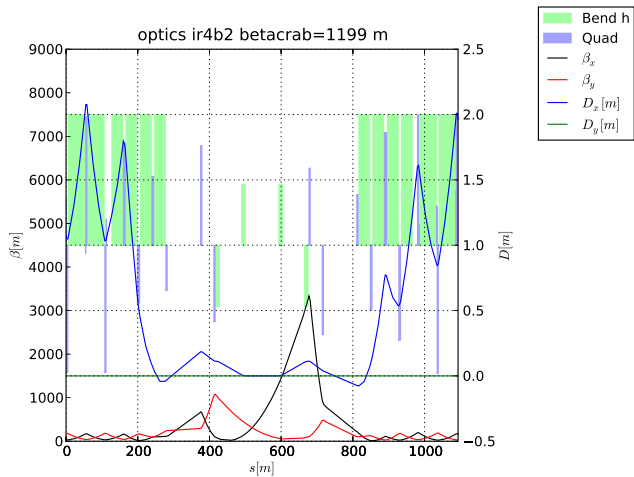

Transition optics

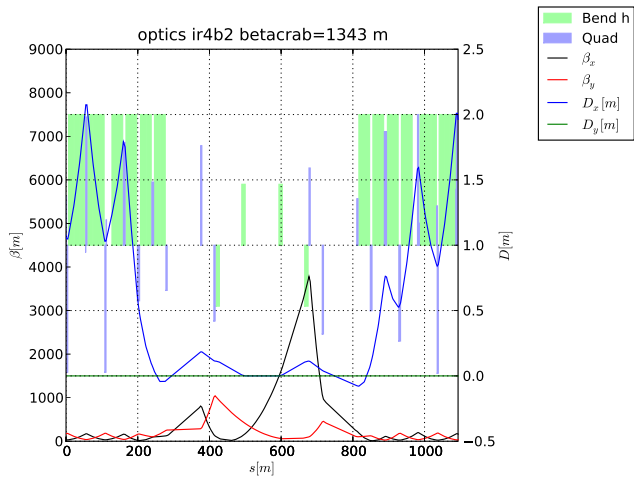

Transition optics

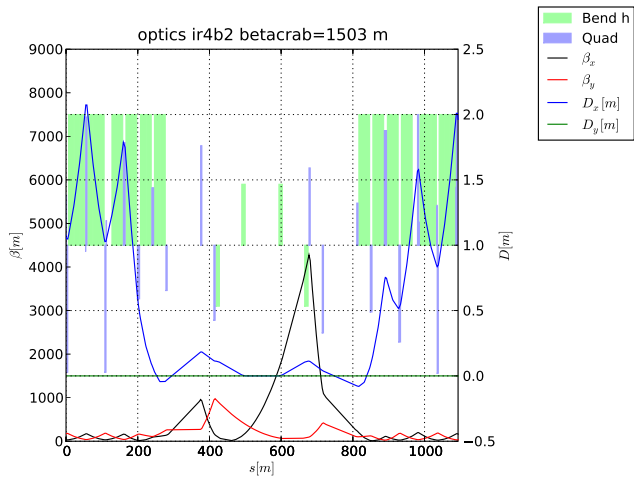

Transition optics

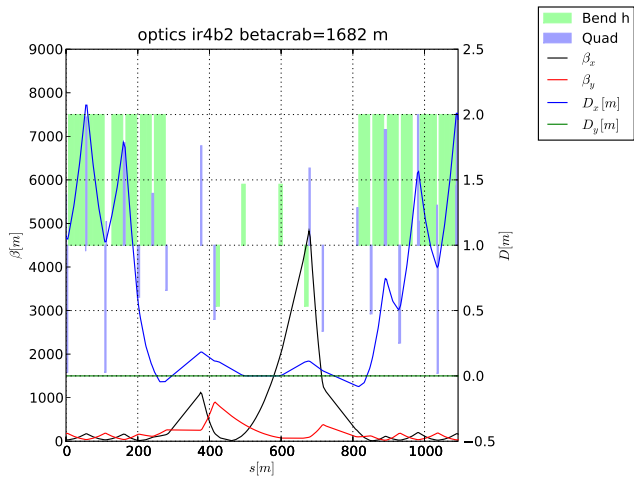

Transition optics

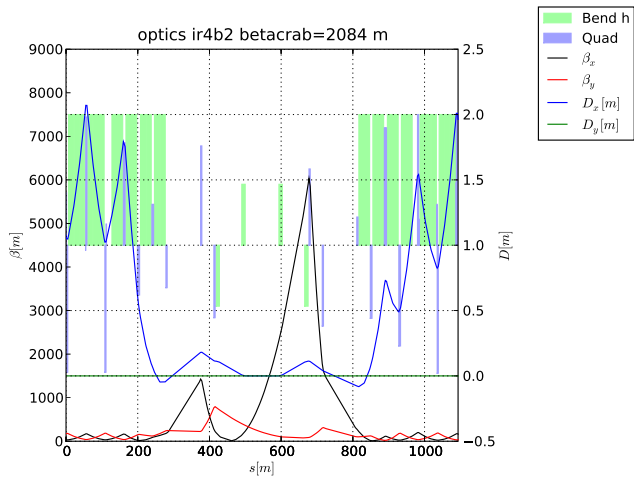

Transition optics

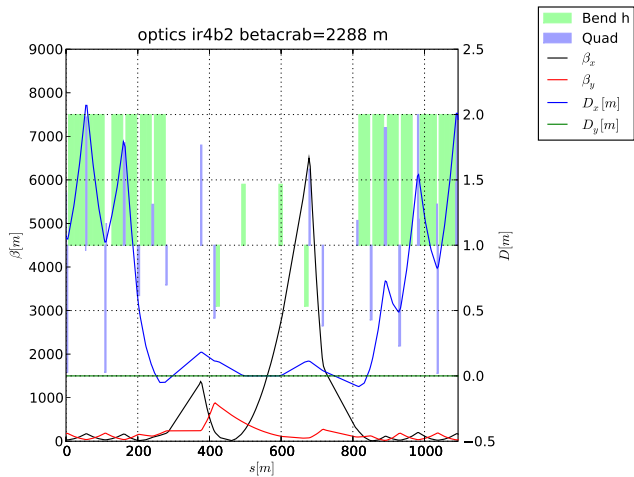

Transition optics

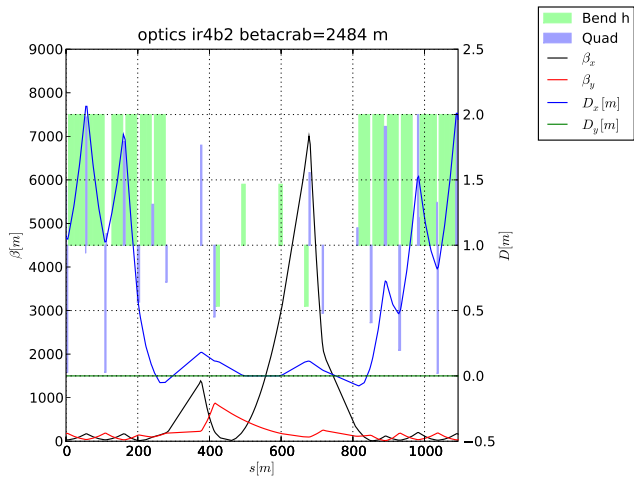

Transition optics

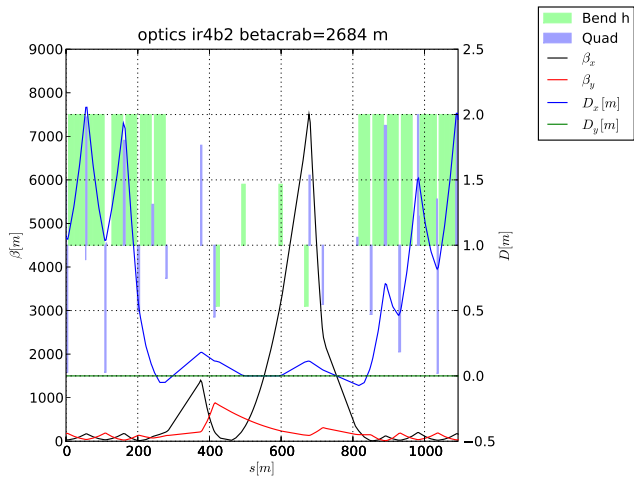

Transition optics

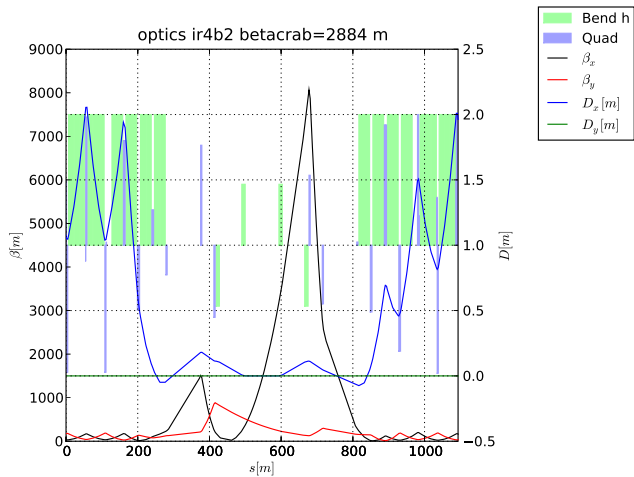

Transition optics

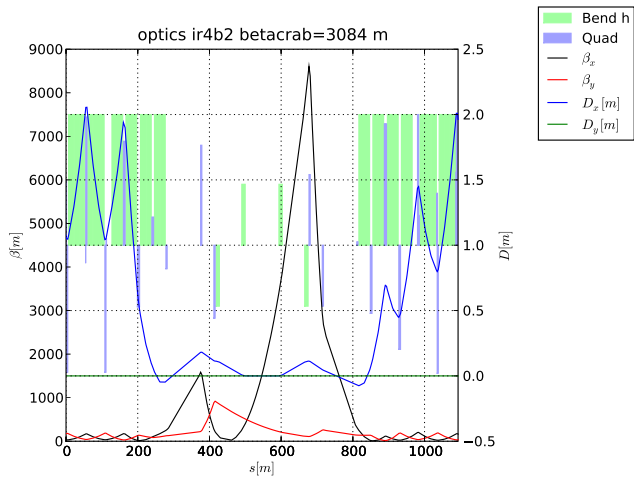

Transition optics

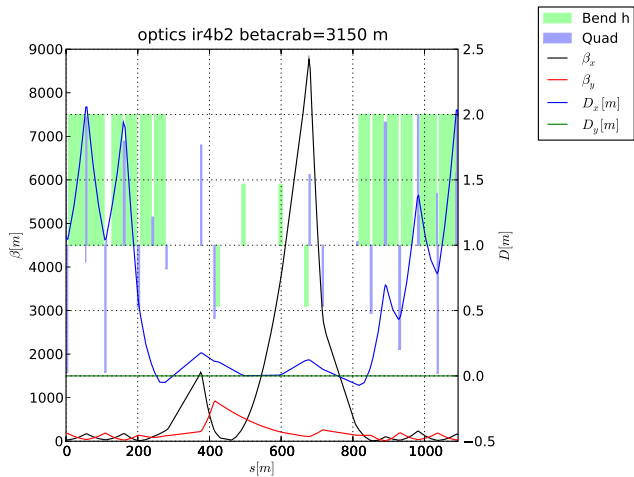

Transition gradients at 7TeV

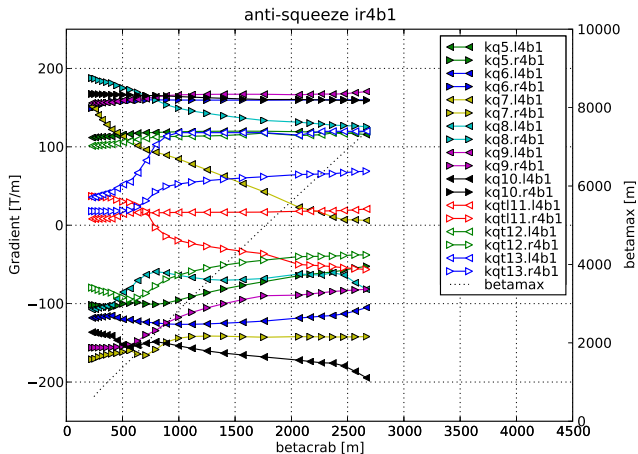

Transition gradients at 7TeV

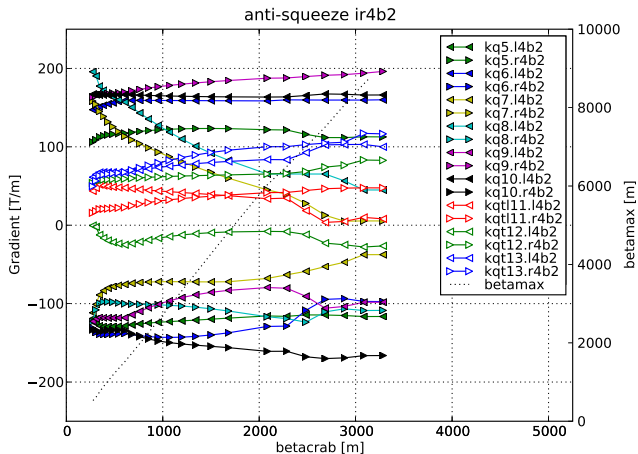

Apertures

Apertures are evaluated using a closed orbit tolerance of 3mm and maximum $\delta p/p=0.00086$. It uses the present aperture model and tolerances.

I present two values, one including the spurious dispersion caused by a dispersion mismatched orbit bump called 'full' and one assuming that dispersion is fully corrected.

I set a target of $n_1=7$ (same as nominal which actually enforced only at triplets that have dedicated collimator). SLHC Phase I aim at $n_1=10$. The aperture calculations do not include the effect of the crab cavity on the collimation (see Yipeng talk).

Apertures Beam 1

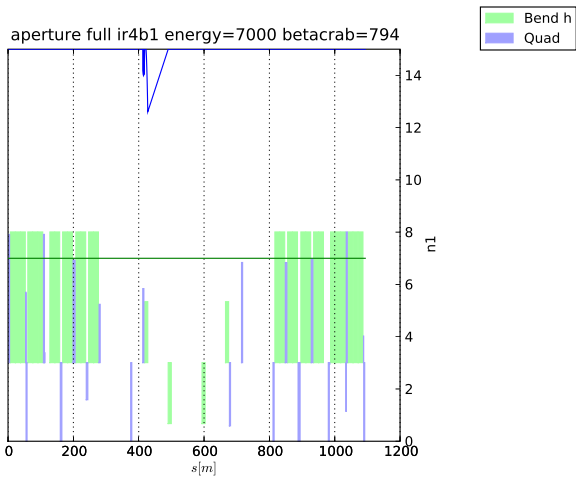

Apertures Beam 1

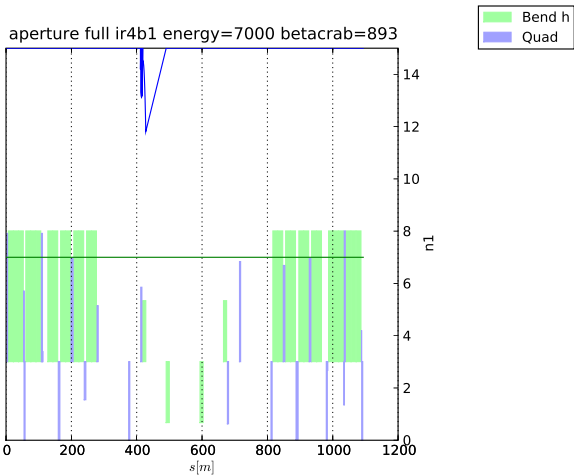

Apertures Beam 1

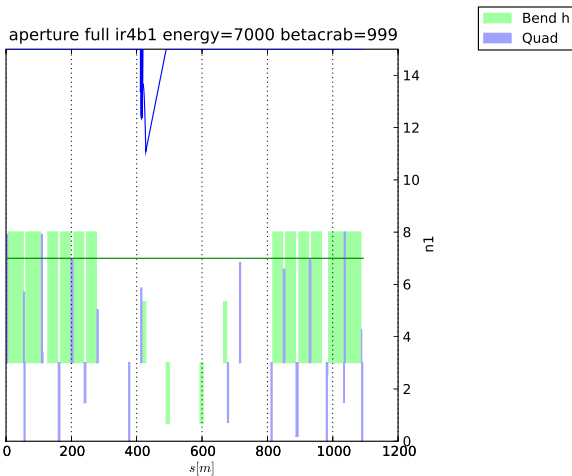

Apertures Beam 1

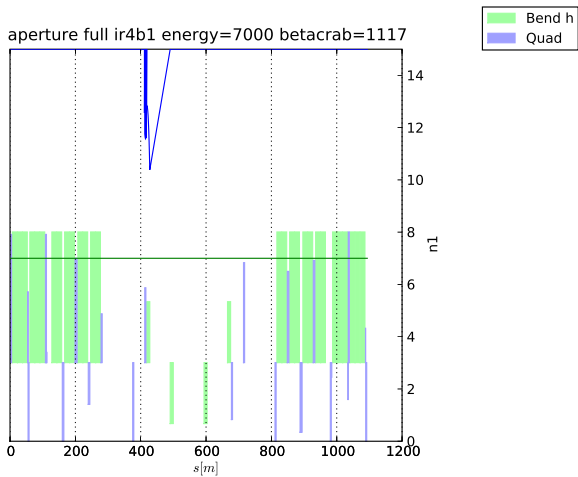

Apertures Beam 1

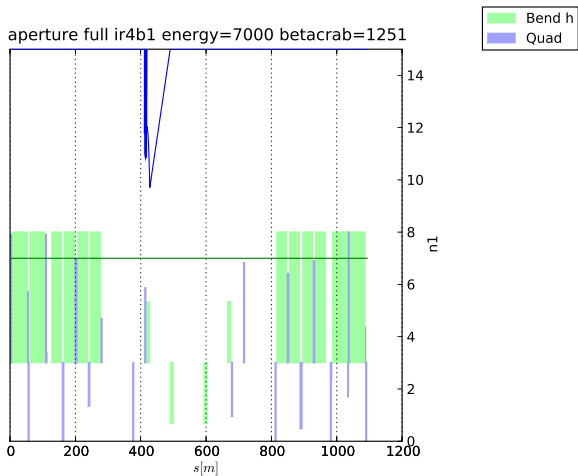

Apertures Beam 1

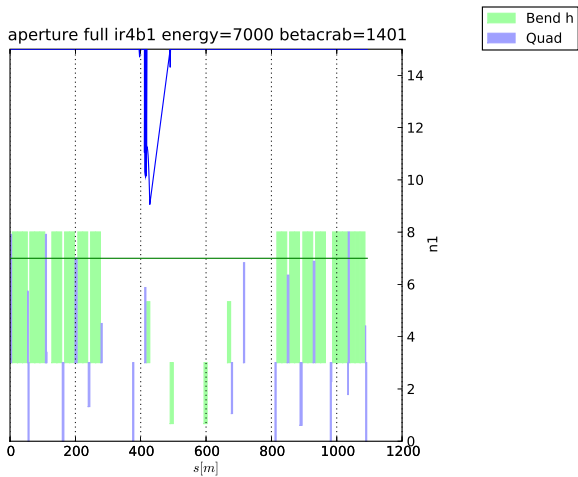

Apertures Beam 1

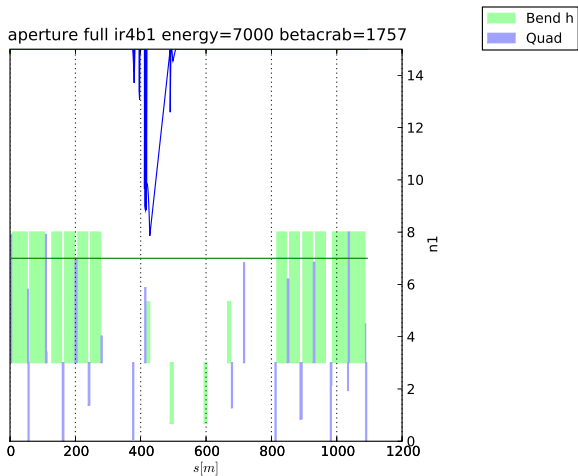

Apertures Beam 1

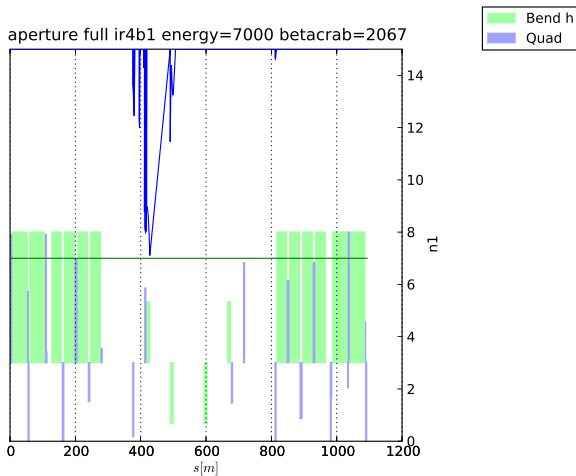

Apertures Beam 1

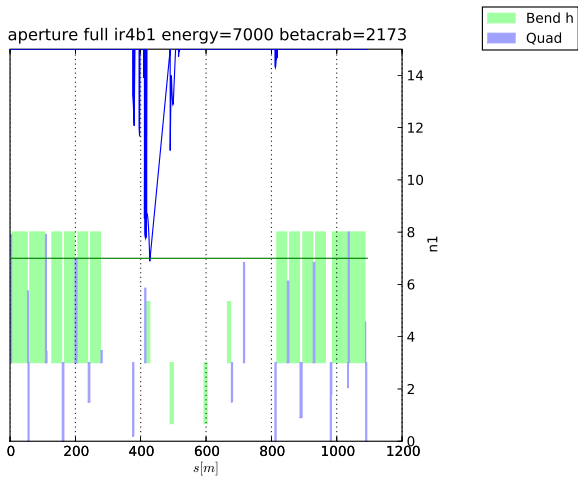

Apertures Beam 1

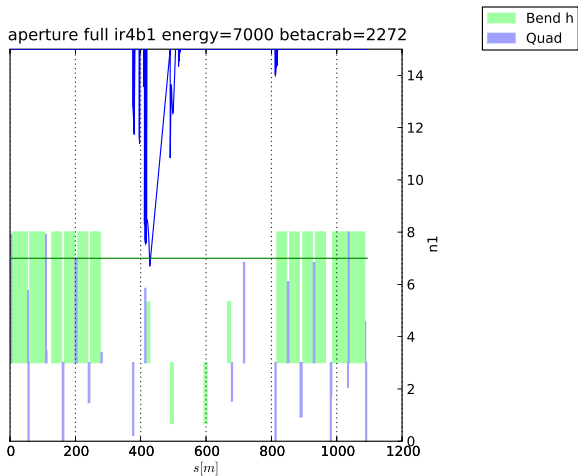

Apertures Beam 1

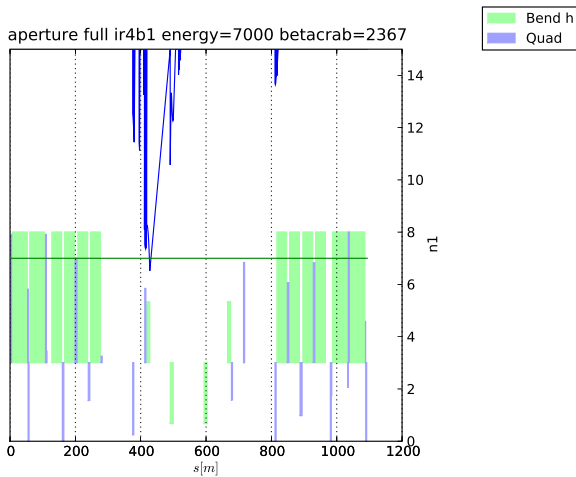

Apertures Beam 1

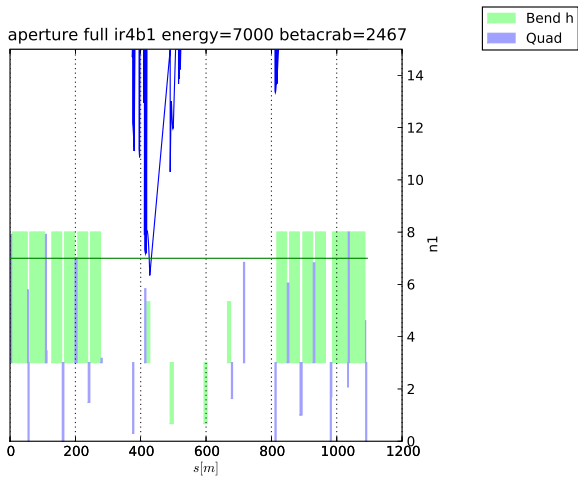

Apertures Beam 1

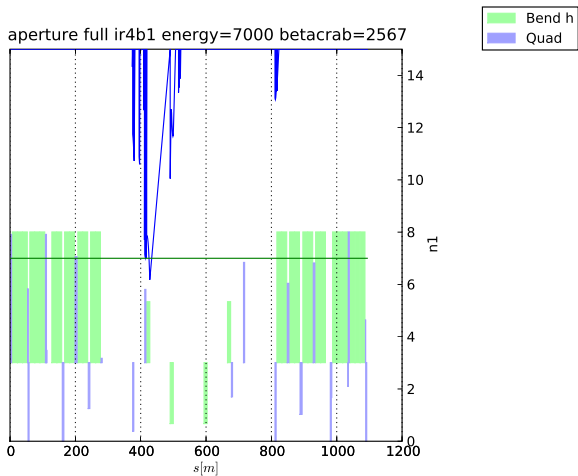

Apertures Beam 1

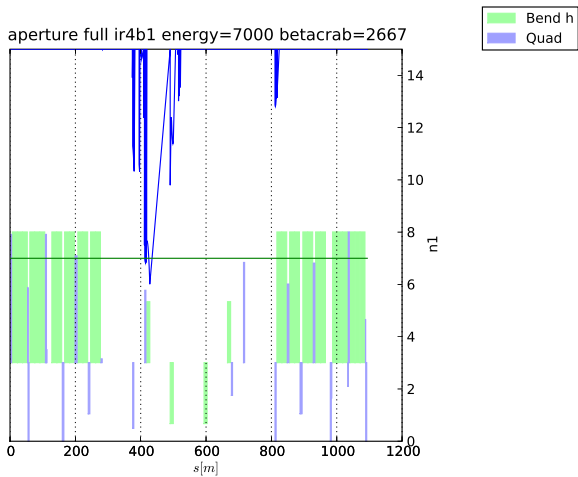

Apertures Beam 1

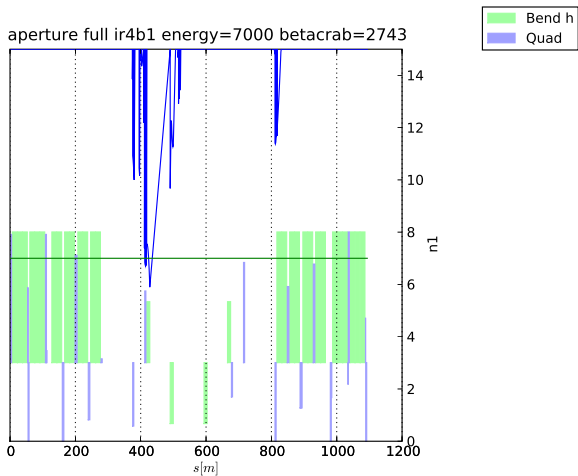

Apertures Beam 2

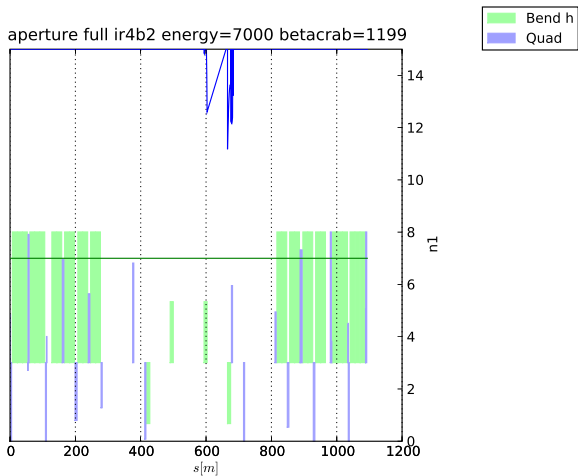

Apertures Beam 2

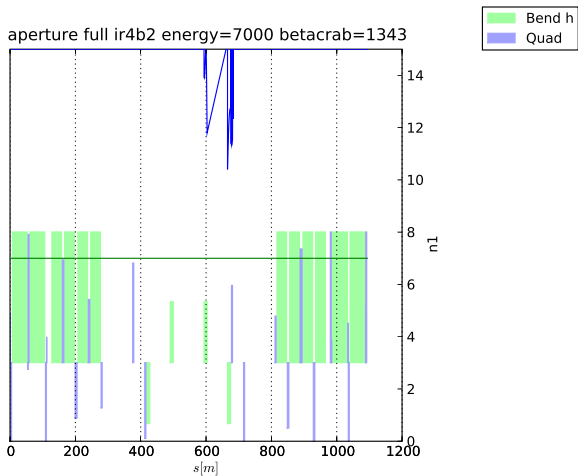

Apertures Beam 2

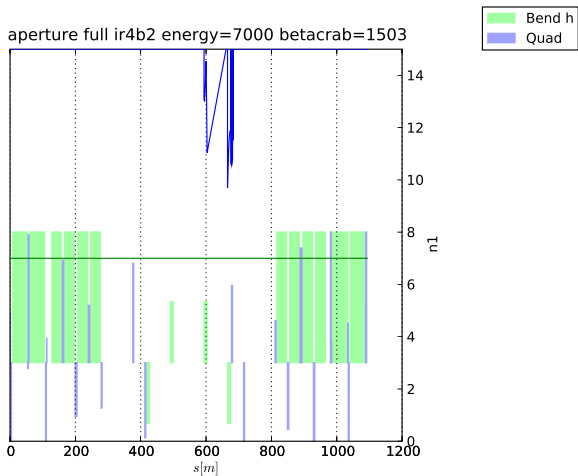

Apertures Beam 2

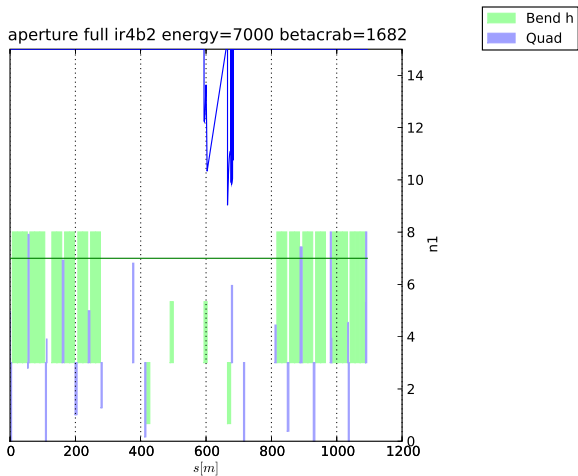

Apertures Beam 2

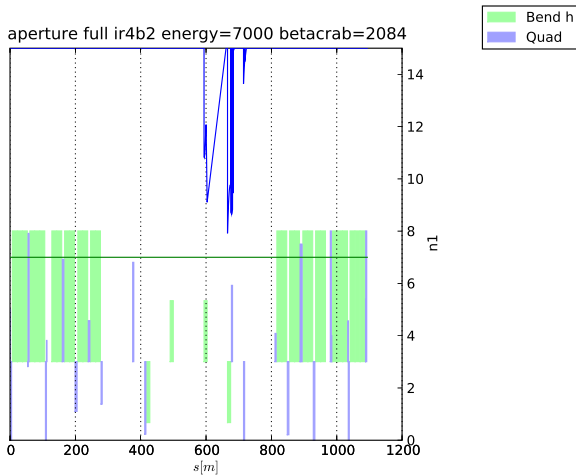

Apertures Beam 2

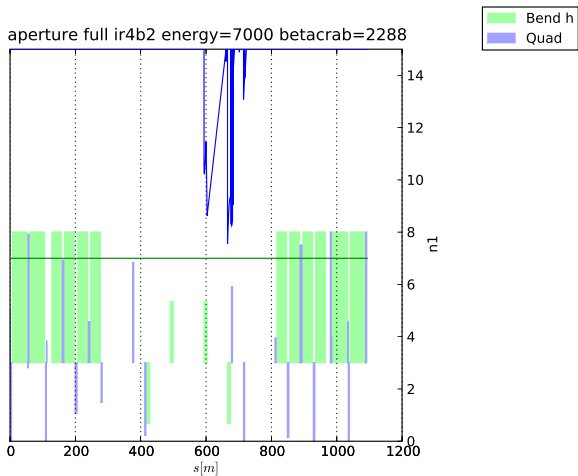

Apertures Beam 2

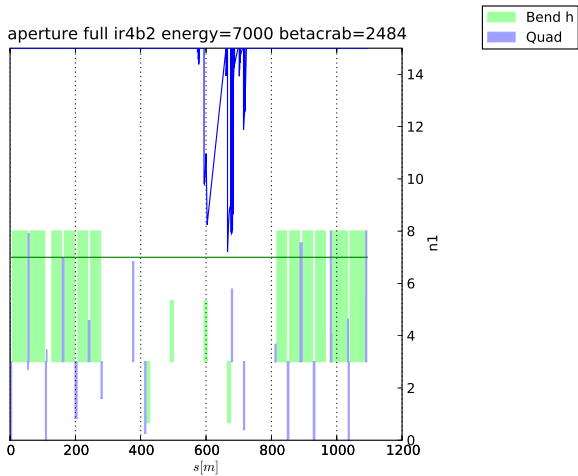

Apertures Beam 2

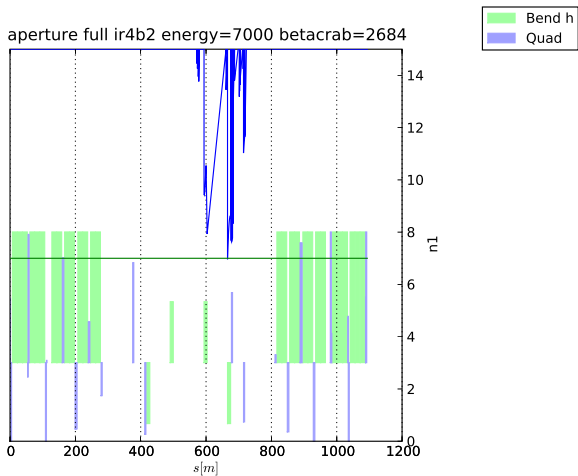

Apertures Beam 2

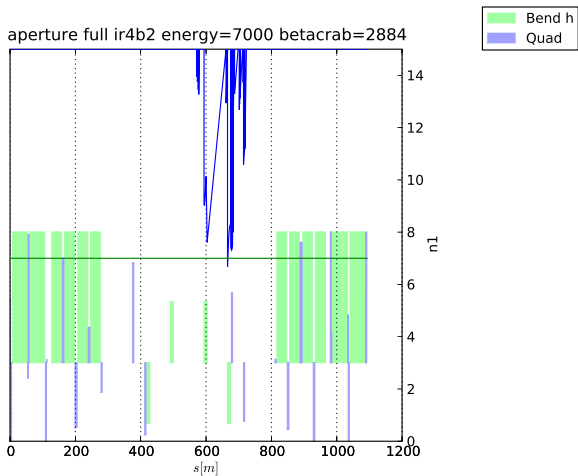

Apertures Beam 2

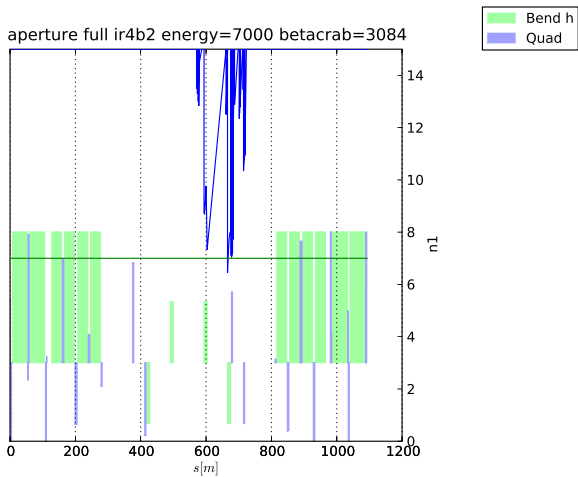

Apertures Beam 2

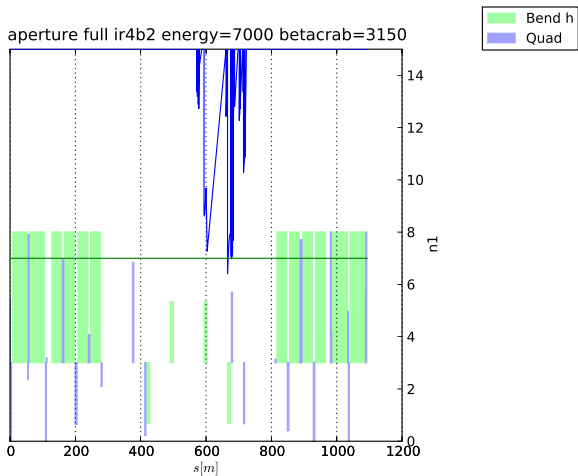

Effect of spurious dispersion

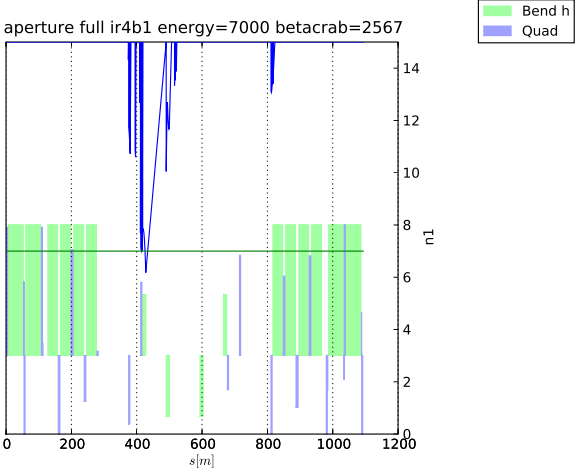

Worse for Beam 1. Studies to compensate the spurious dispersion are on ongoing.

Effect of spurious dispersion

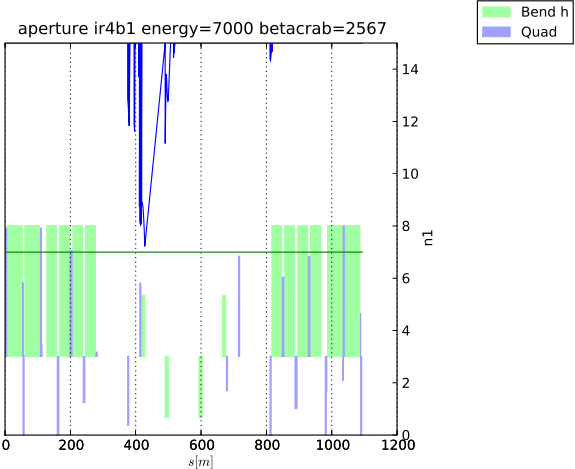

Worse for Beam 1. Studies to compensate the spurious dispersion are on ongoing.

Effect of spurious dispersion

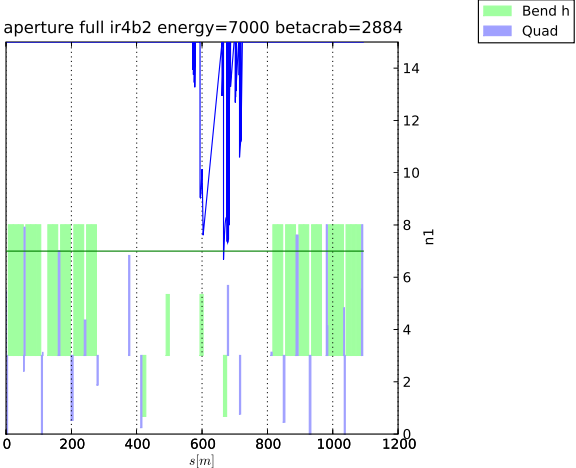

Worse for Beam 1. Studies to compensate the spurious dispersion are on ongoing.

Effect of spurious dispersion

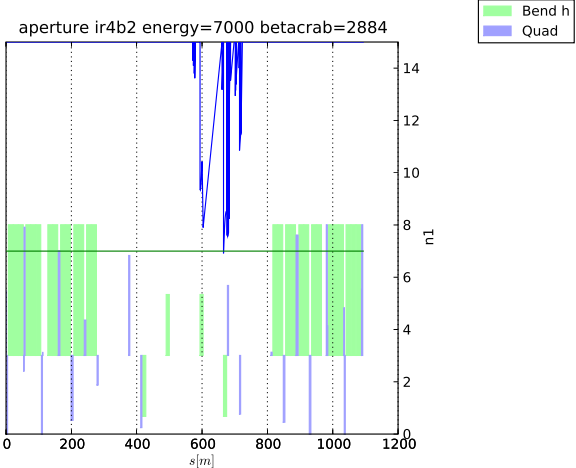

Worse for Beam 1. Studies to compensate the spurious dispersion are on ongoing.

Apertures summary

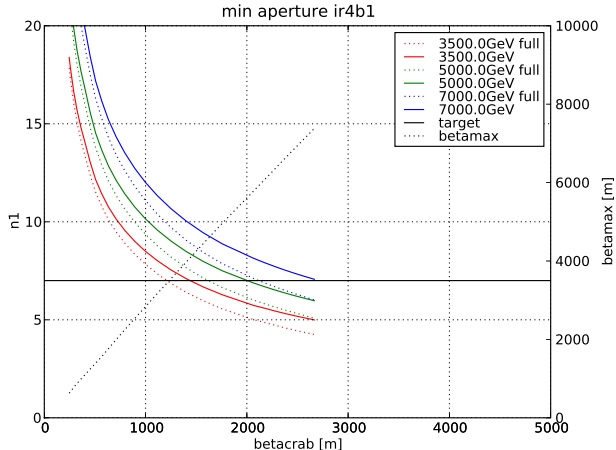

As the emittance decreases with energy, each step of the squeeze has a minimum energy that is compatible with the aperture. This information allow to choose betacrab and energy depending on the purpose of the test and machine conditions.

Apertures summary

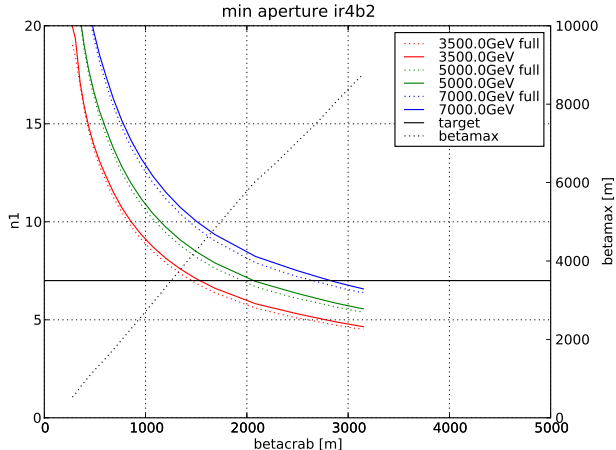

As the emittance decreases with energy, each step of the squeeze has a minimum energy that is compatible with the aperture. This information allow to choose betacrab and energy depending on the purpose of the test and machine conditions.

Phase advance during the un-squeeze

During the squeeze the $\psi_{cc \rightarrow ip}^x$ changes by 0.05 unit from the ideal condition. At high beta IR4 loses part of his tunability and there is not enough flexibility to recover the optimum phase advance.

We assume that the arcs can be perturbed from nominal condition either before operations or after the un-squeeze to meet optimal conditions at the end of the un-squeeze (this is more complicated for 30cm β^* for which phase constraints are tighter).

The LHC damper relies on BPMC at Q9 and Q7 and ADTK[HV] close to Q6. If in operation during the test, the settings must be adapted to the changing values of beta and phase.

Other instrumentation might be affected but the beam size will never be larger the injection size in absolute value.

Phase changes during the un-squeeze

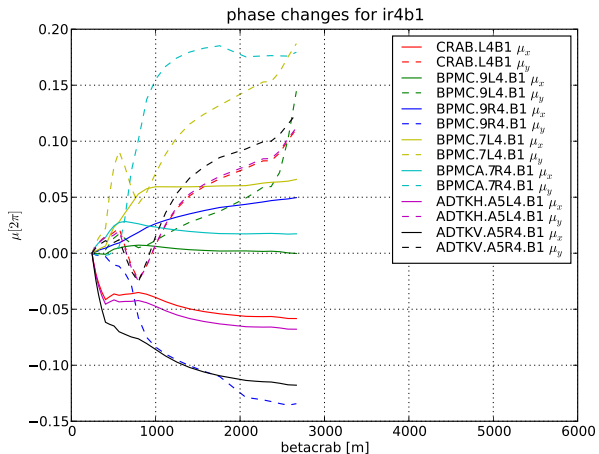

Phase changes during the un-squeeze

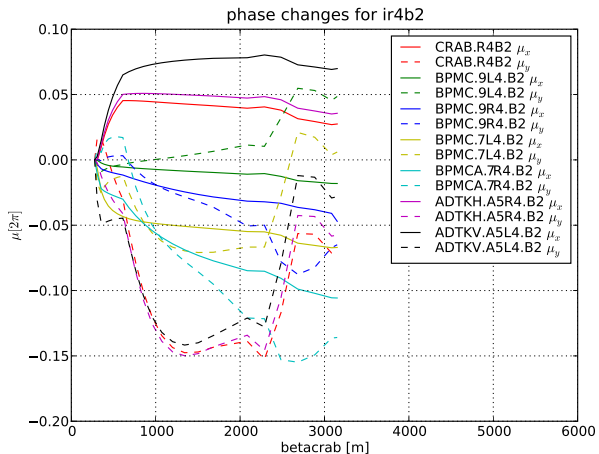

Beta changes during the un-squeeze

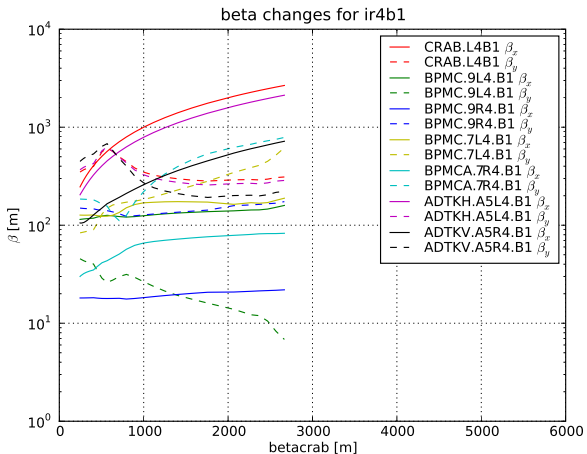

Beta changes during the un-squeeze

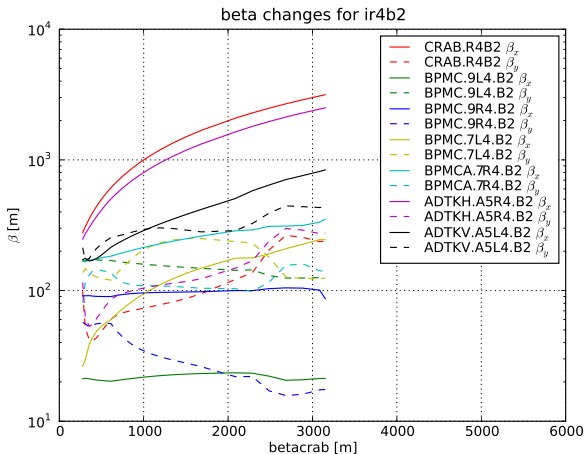

Chromaticity changes during the un-squeeze

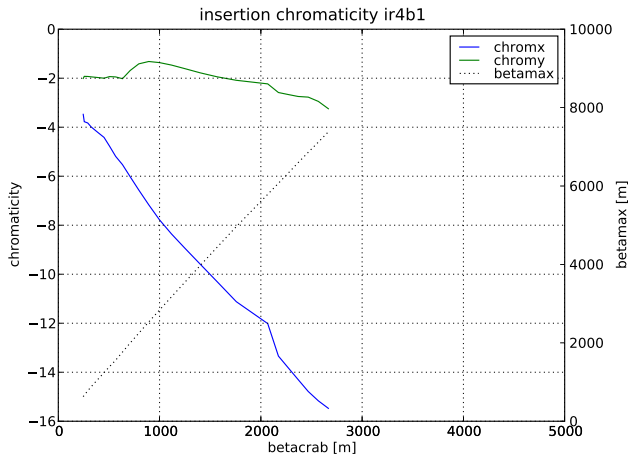

Chromaticity changes during the un-squeeze

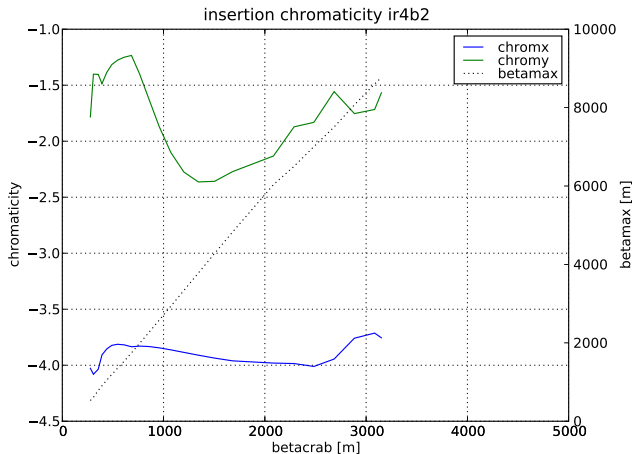

Luminosity definitions

LHC luminosity can be approximated by:

$$\mathcal{L} = \mathcal{L}_{\text{ho}} F_{\text{geo}} \quad \mathcal{L}_{\text{ho}} = \frac{N_b^2 n_b f_{\text{rev}}}{4\pi\epsilon\beta^*} \quad F_{\text{geo}} = 1/\sqrt{\left(1 + \frac{\sigma_z\theta_c}{2\sigma^*}\right)^2}$$

$$0 < \frac{2\sigma^*}{\sigma_z\theta_c} < F_{\text{geo}} < 1$$

The luminosity with the crab cavity is bounded between the head-on and crossing angle luminosity.

The estimation of luminosity with RF is not trivial because one has to include the RF sinusoidal distortion. Full details will be given by Yipeng.

Luminosity expectations

The following set of parameters illustrates the expected effect of the luminosity on the crab cavity on various conditions:

Energy	β^*	θ_{crossing}	$\frac{\mathcal{L}_{\text{ho}}}{\mathcal{L}_{\text{nocrab}}}$	V_{crab}	β_{crab}	$\frac{V_{\text{crab}}}{V_{\text{fullcomp}}}$	$\frac{\mathcal{L}_{\text{cr}}}{\mathcal{L}_{\text{nocrab}}} - 1$
7TeV	30cm	409urad	1.60	2.5MV	2.6km	0.50	~ 18%
7TeV	55cm	302urad	1.21	2.5MV	2.6km	0.90	~ 13%
5TeV	42cm	409urad	1.34	2.5MV	2.0km	0.70	~ 15%
3.5TeV	60cm	409urad	1.18	2.5MV	1.3km	1.00	~ 10%

Assumed: moderate 2.5MV max voltage, optimum phase advance, $\epsilon_n = 3.75\text{mm mrad}$, $d_{\text{sep}} = 10\sigma$, $N_b = 1.15 \cdot 10^{11}$, $\sigma_z = 7.55\text{cm}$, $n_b = 2808$, gaussian beam.

The scenarios presented differ as less as possible from nominal conditions.

Luminosity expectations

The following set of parameters illustrates the expected effect of the luminosity on the crab cavity on various conditions:

Energy	β^*	θ_{crossing}	$\frac{\mathcal{L}_{\text{ho}}}{\mathcal{L}_{\text{nocrab}}}$	V_{crab}	β_{crab}	$\frac{V_{\text{crab}}}{V_{\text{fullcomp}}}$	$\frac{\mathcal{L}_{\text{cr}}}{\mathcal{L}_{\text{nocrab}}} - 1$
7TeV	30cm	409urad	1.60	2.5MV	2.6km	0.50	~ 18%
7TeV	55cm	302urad	1.21	2.5MV	2.6km	0.90	~ 13%
5TeV	42cm	409urad	1.34	2.5MV	2.0km	0.70	~ 15%
3.5TeV	60cm	409urad	1.18	2.5MV	1.3km	1.00	~ 10%

Several assumptions have been made: one crab cavity per beam, some optics and operational flexibility, optimistic on aperture (S. Fartoukh suggests at least $n_1=10$ like in the phase I, that requires half emittance to keep the beta crab estimates).

Luminosity expectations

The following set of parameters illustrates the expected effect of the luminosity on the crab cavity on various conditions:

Energy	β^*	θ_{crossing}	$\frac{\mathcal{L}_{\text{ho}}}{\mathcal{L}_{\text{nocrab}}}$	V_{crab}	β_{crab}	$\frac{V_{\text{crab}}}{V_{\text{fullcomp}}}$	$\frac{\mathcal{L}_{\text{cr}}}{\mathcal{L}_{\text{nocrab}}} - 1$
7TeV	30cm	409urad	1.60	2.5MV	2.6km	0.50	~ 18%
7TeV	55cm	302urad	1.21	2.5MV	2.6km	0.90	~ 13%
5TeV	42cm	409urad	1.34	2.5MV	2.0km	0.70	~ 15%
3.5TeV	60cm	409urad	1.18	2.5MV	1.3km	1.00	~ 10%

There is set of solutions compatible with a variety of parameters: requirements from collimation, top energy, values of beta crab. They allow to adapt to the machine parameter and they also offer knobs for gradual luminosity enhancement or reduction experiments.

Variations

Beta max is 3 times larger than beta crab, which is not an efficient use of the aperture: IR4 was not designed for crab cavities (and it has less quad w.r.t the other insertions).

I didn't use additional gradient reserve for low energy operation to reduce phase shifts. I didn't use the total phase advance of the insertion to further optimize the beta crab. I didn't implement the squeeze on the ramp to reduce the constraints at injection.

It is possible that crossing in the vertical plane offer better optics because it is less constrained by the dispersion conditions.

Installing bipolar power supplies for few magnets improve flexibility and may improve performance in terms of beta crab / beta max and tunability but transition to injection becomes complicated (see backup slides).

Placing the two crab cavities on the same side is much more complicated from the optics points of view, because for one beam the beta will be naturally smaller.

Future work

Fix machine parameters, then study

- ▶ Linear imperfection,
- ▶ Dynamic aperture,
- ▶ Beam-beam,
- ▶ Collimation,
- ▶ Halo and background,
- ▶ Tunability,

and iterate optimization on optics and machine parameters.

Thanks!

Polarity change optics

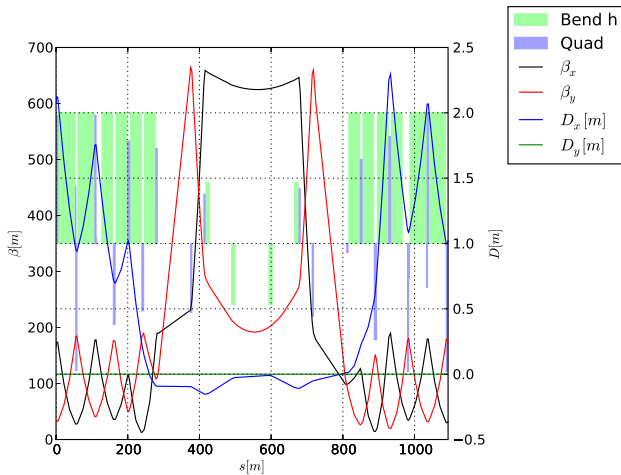

betacrab 2.2km, apfull 10σ , ap 11.5σ

Polarity change optics

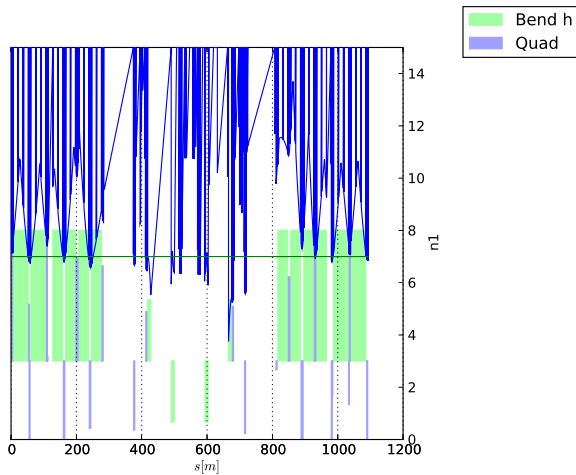

betacrab 2.2km, apfull 10σ , ap 11.5σ

Polarity change optics

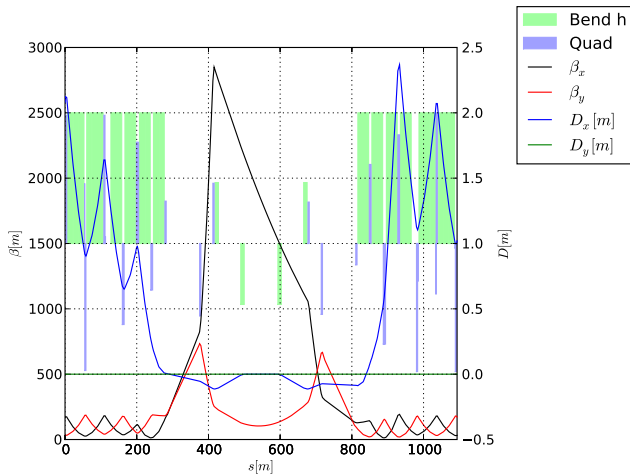

betacrab 2.2km, apfull 10σ , ap 11.5σ

Polarity change optics

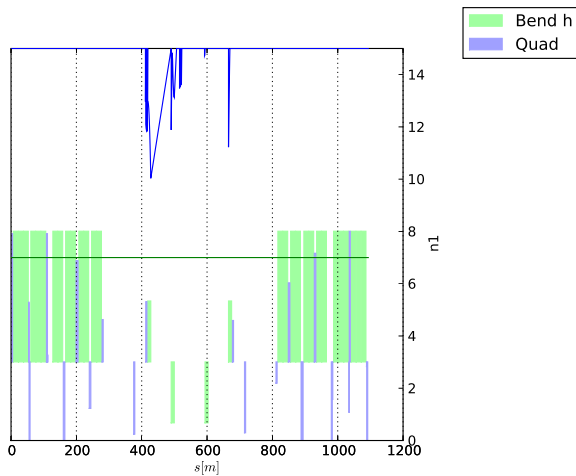

betacrab 2.2km, apfull 10σ , ap 11.5σ

Failures scenarios beyond the prototype test with full beam

Failure scenarios for phase II with full beam, that might be tested during the prototype test:

- ▶ power supply trip
- ▶ cavity quench
- ▶ cryogenic failure
- ▶ single cavity trip
- ▶ coupler failure
- ▶ vacuum problems
- ▶ RF loops problems