

LARP

LARP Support of Crab Cavity Effort

Eric Prebys

Fermilab APC

LARP Program Director

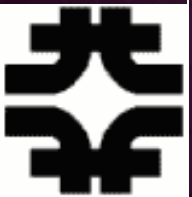

Sept. 18, 2009

LHC Accelerator Research Program (LARP)



- Proposed in 2003 to coordinate efforts at US labs related to the LHC accelerator (as opposed to CMS or ATLAS)
 - Originally FNAL, BNL, and LBNL
 - SLAC joined shortly thereafter
 - Some work (AC Dipole) supported at UT Austin
 - Can consider new membership (Jlab?)
- LARP Goals
 - Advance International Cooperation in High Energy Accelerators
 - Advance High Energy Physics
 - By helping the LHC integrate luminosity as quickly as possible
 - Advance U.S. Accelerator Science and Technology
- LARP includes projects related to initial operation, but a significant part of the program concerns the LHC upgrades

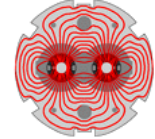

⦿ Accelerator Systems (~\$3M/year)

- Accelerator physics
- Instrumentation and other hardware
 - Collimation
 - LLRF
 - Crab cavities?

Crab cavities would come out of this

⦿ Magnet Systems (~\$5M/year)

- Goal: demonstrate Nb_3Sn as a viable technology for the ultimate upgrade of the LHC

⦿ Programmatic Activities (~2M/year)

- Program management, travel, meetings, etc
- Toohig Fellowship
- Long Term Visitor (LTV) program

+~\$2M contingency divided among tasks as needed throughout year

LARP Instrumentation Contributions to initial LHC Operation



◉ Schottky detector

- Used for non-perturbative tune measurements (+chromaticities, momentum spread and transverse emmitances)

◉ Tune tracking

- Implement a PLL with pick-ups and quads to lock LHC tune
- Investigating generalization to chromaticity tracking

◉ AC dipole

- US AC dipole to drive beam
- Measure both linear and non-linear beam optics

◉ Luminosity monitor

- High radiation ionization detector integrated with the LHC neutral beam absorber (TAN) at IP 1 and 5.



LARP Accelerator R&D for future LHC



Rotatable collimators

- Can rotate different facets into place after catastrophic beam incidents
- Aim for prototype this year

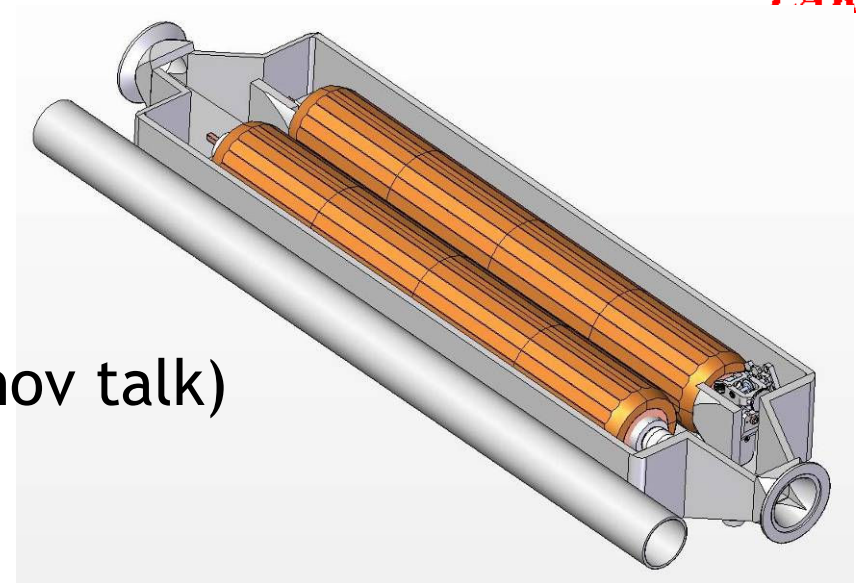

Crystal Collimation (See Mokhov talk)

- CRYSTAL Collaboration
- T980

Beam-beam studies

- General simulation
- Electron lens (See Shiltsev talk)
- Wire compensation

Electron cloud studies

- Study effects of electron cloud in LHC and injector chain (see Furman talk)

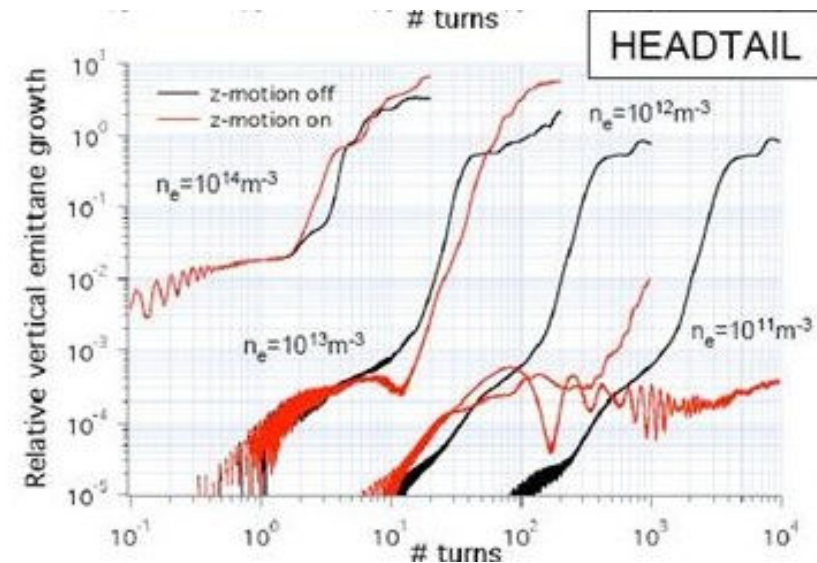

A Few Words about LARP Accounting...



- Somewhere between US and European Rules
 - LARP funds pay for materials and services (M&S), most technical and engineering labor, and some scientific labor
 - Significant scientific labor and some engineering labor contributed out of lab core programs
- That \$3M/year is really more like \$6M if we count everything (with all overhead).
 - Remember that by US accounting rules, a “physicist” is about \$250-300k/year.

LARP Model

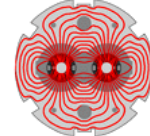

LARP

- LARP funds R&D.
 - If technology looks promising, the hope is that it will be taken over by CERN or spun off as a separate project in the US
 - eg, “Accelerator Projects for the Upgrade of the LHC” (APUL) magnet program, which is building D1 separators and feebboxes for the Phase I upgrade.
 - Not really structured like a project, so try to avoid “hard deliverables”
 - Got into some trouble with this with the Lumi monitors
- Crab cavities (even just the US part) too big to fit within LARP
 - Multi-M\$
- LARP can take a steering role in the US R&D, but if crab cavities take off, they will have to get dedicated funding from the DOE
 - ie, don’t assume “LARP funding” is the same as “US funding”
 - LK Len can say more about that than me.

General Trends in LARP Accelerator Funding



- Historically dominated by two projects
 - Rotatable Collimator
 - Lumi Monitor
 - Together made up ~2/3 of Accelerator Systems Budget
- As these ramp down, projects which are moving to take their place include
 - R&D for PS2
 - Lots of interest at CERN and in US
 - Synergy with Project X
 - Well matched to LARP
 - E-cloud feedback in SPS
 - Mostly SLAC and LBL
 - Crab cavities
 - Interesting, but no way LARP can support entire US end.
 - Have taken a “wait and see” attitude

Potential Funding for Crab Cavities in FY10

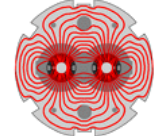

LARP

- ⦿ Initial FY10 budget: Total \$337k
 - BNL: \$256k
 - Mostly Rama
 - FNAL: \$6k
 - Travel
 - LBNL: \$6k
 - Travel
 - SLAC: \$69k
 - Continue R&D on SLAC cavity design
- ⦿ Pending outcome of review
 - Could potentially release ~few hundred k\$ from contingency over course of year

Funding Beyond FY10



- Rotatable Collimator budget will ramp down further, which could free up money for crab cavities, *however*, overall budget expected to shrink as budget for Phase I magnet program (APUL) grows:
 - Bottom line: LARP crab cavity support will probably stay in the range \$300k-\$600k/year.
 - With a strong signal from CERN, it could go higher, but probably not to the \$1M/year level.
- Caveat:
 - LARP will not continue to support efforts for a Phase I (IR4) test unless there is an unambiguous commitment from CERN to support such a test.

Latest CERN Schedule (for what it's worth)

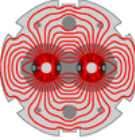

LARP

Priorities		2010				2011				2012				2013				2014					
		Q4	Q1	Q2	Q3	Q4	Q1	Q2	Q3	Q4	Q1	Q2	Q3	Q4	Q1	Q2	Q3	Q4	Q1	Q2	Q3	Q4	
1	LHC Operation assumed	○	○	○	○	○	Sh	Sh	○	○	Sh	○	○	○	Sh	○	○	○	Sh	Sh	○	○	
1	SPS operation and exploitation	○	○	○	○	○	Sh	○	○	○	Sh	○	○	○	Sh	○	○	○	Sh	Sh	Sh	○	○
1	PS Operation and Exploitation	○	○	○	○	○	Sh	○	○	○	Sh	○	○	○	Sh	○	○	○	Sh	Sh	Sh	○	○
1	Booster Exploitation and Operation	○	○	○	○	○	Sh	○	○	○	Sh	○	○	○	Sh	○	○	○	Sh	Sh	Sh	○	○
1	Source/LINAC2 op and exploitation	○	○	○	○	○	Sh	○	○	○	Sh	○	○	○	Sh	○	○	○	Sh	Sh	Sh	Sh	Sh
	Linac3/LEIR/Ions Operation	Sh	Sh	○	○	○	Sh	○	○	○	Sh	○	○	○	Sh	○	○	○	Sh	Sh	Sh	○	○
1	LHC 3-4 magnet repair for spares		C	C	C	C																	
1	Consolidation all accelerators	C	C	C	C	C	C	C	C	C	C	C	C	C	C	C	C	C	C	C	C	C	C
2	LINAC4 assumed	C	C	C	C	C	C	C	C	C	C	C	C	C	C	C	C	C	Sh	Sh	Sh	○	○
2	Inner Triplets assumed	C	C	C	C	C	C	C	C	C	C	C	C	C	C	C	C	C	Sh	Sh	Sh	○	○

Potential
Crab Cavity
Installation?

↑
Phase I
Upgrades

- Could CERN commit to a crab cavity test in IR4 in 2013?
 - And could we meet that schedule?

My “take away” from this meeting so far...



- ⦿ The case for crab cavities has gotten very strong
- ⦿ At this point:
 - Could *possibly* down-select from among 800 MHz elliptical designs
 - Nowhere near the point to choose among compact designs.
- ⦿ However, elliptical cavities don't appear feasible for the local solution.
- ⦿ This raises the question whether there is a point to developing the elliptical cavities at all:
 - Still a question whether Phase I test will occur.
 - Would it make more sense to put all our efforts into the final solution.

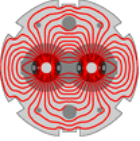

Important Questions

- ⦿ Can we get a commitment that a Phase I test can occur? *LARP*
- ⦿ Can we meet that timescale?
- ⦿ What will “CERN” accept as evidence that crab cavities are a viable technology:
 - Is a Phase I test in the LHC necessary?
 - Does it tell us enough?
 - Could we do a test in the SPS or elsewhere?
- ⦿ Can crab cavities be made “safe”?
 - Potential show stopper
- ⦿ Can IR4 be modified to permanently accommodate elliptical cavities?
 - If so, is a global scheme potentially the best solution?