



## **« Crab-cavity cryomodule and related infrastructure in SPS LSS6 (EYETS 2016-2017) »**

G. Vandoni, F. Galleazzi, S. Mehanneche, C. Pasquino

<https://edms.cern.ch/document/SPS-LJ-EC-0006/0.1/TAB3>

13th HL-LHC TCC, 4th August 2016

Preceded by: <https://edms.cern.ch/document/1604149/1.0> Space reservation

## « Crab-cavity cryomodule and related infrastructure in SPS LSS6 (EYETS 2016-2017) »

G. Vandoni, F. Galleazzi, S. Mehanneche, C. Pasquino

<https://edms.cern.ch/document/SPS-LJ-EC-0006/0.1/TAB3>

ECR, in the  
SPS

and the

HL-LHC framework

SPS approval list

Coordination

Safety coordination

Concerned colleagues in SPS

Concerned WP leaders

PSO

Integration Officer

Schedule Officer

Budget Officer

Concerned colleagues in HiLumi

Followed by: ECR for Surface building

# Cryogenics architecture

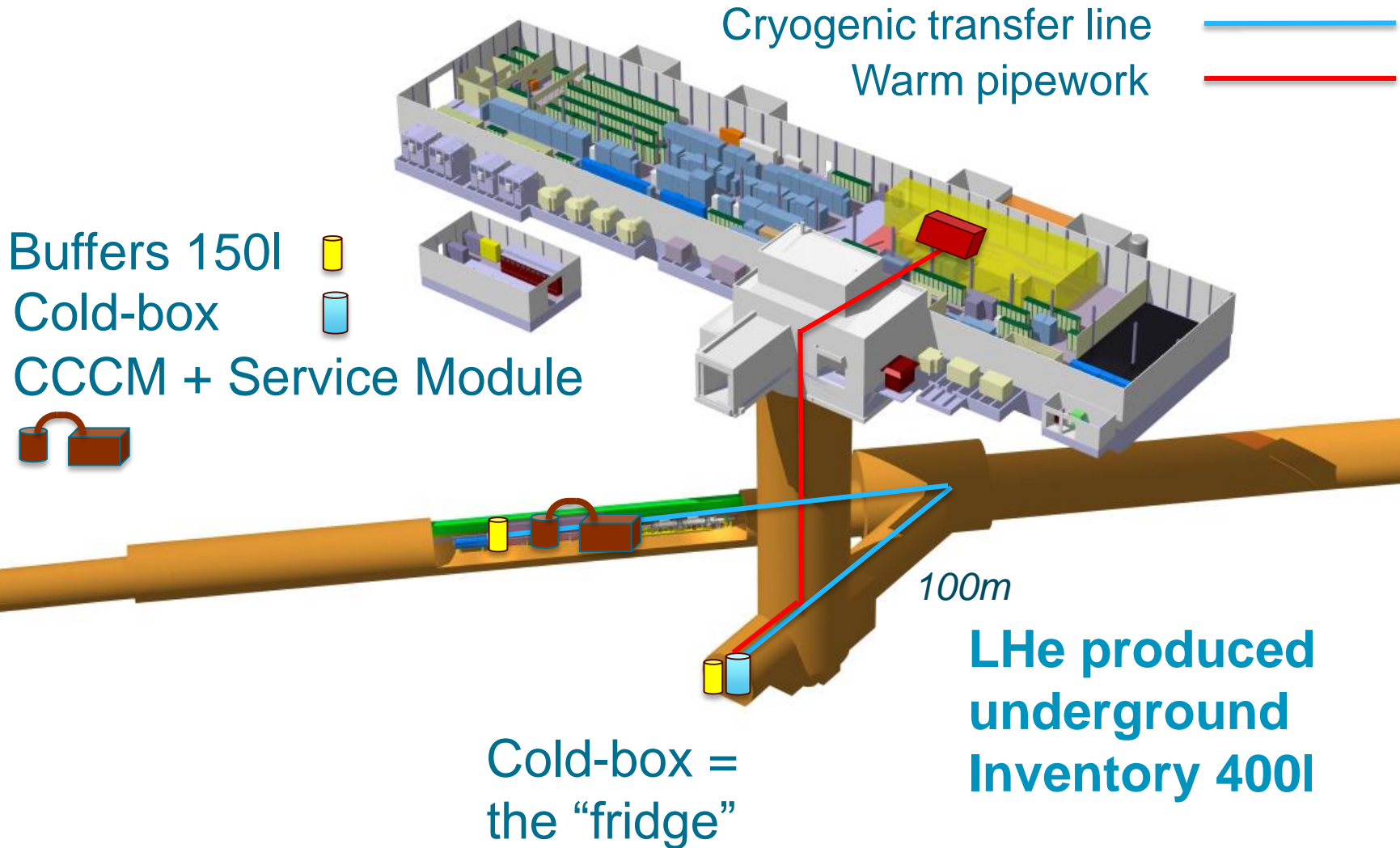

# Layout SPS LSS6

6149

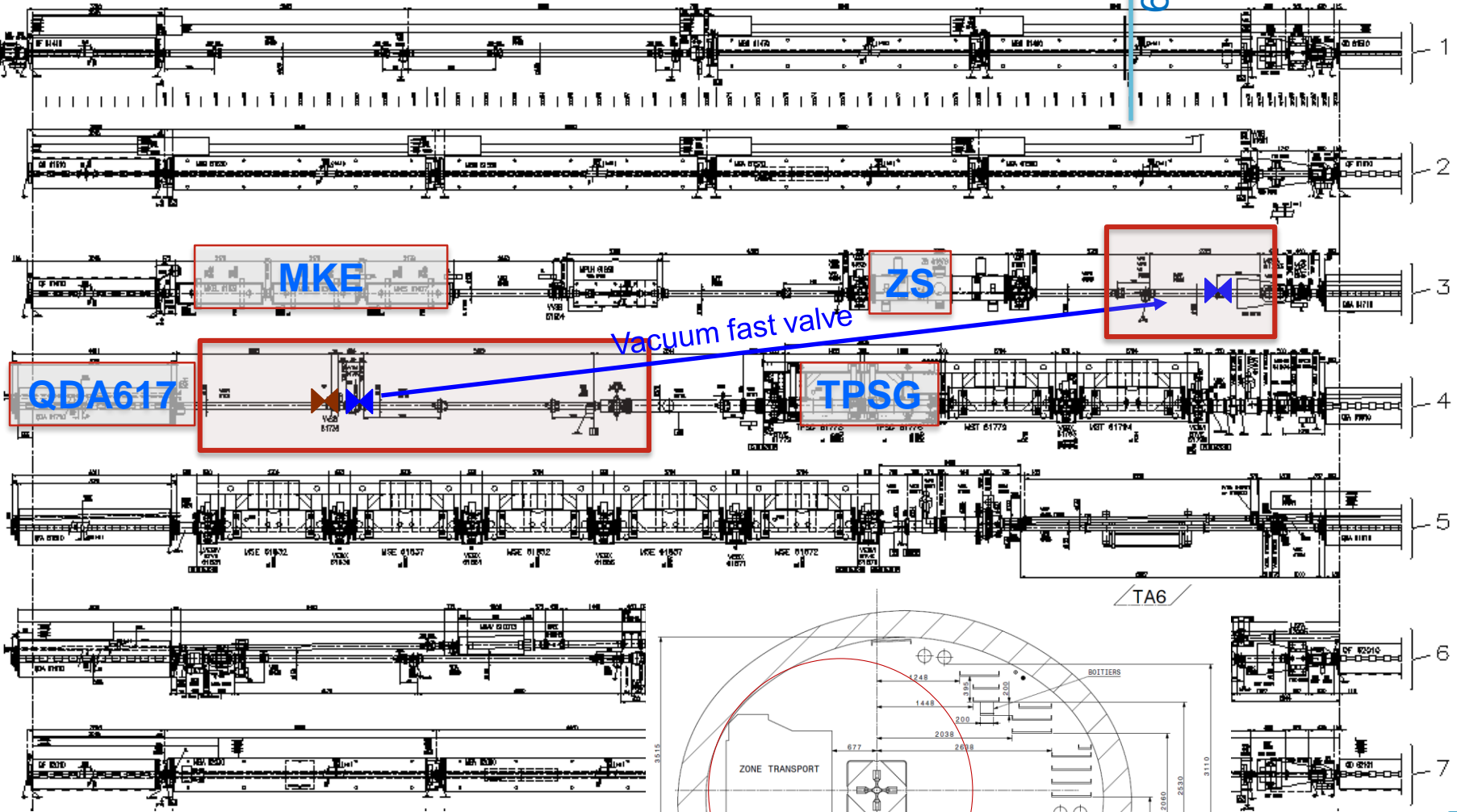

# EYETS 2016-2017 main activities

1 Supporting structures in BA6/

Integrated with the reinforcement project steered by HSE and SMB. In EYETS, must come before cabling

2 Cables/ RF waveguides

Uncabling 4.8km  
Routing under false floor and shaft

3 Cryogenic distribution line installation

Installed by contractor, routed at the tunnel vault, 6m sections, requires scaffolding and welding in the tunnel. 4 weeks by contract

4 Vacuum layout modification

Vacuum chambers (carbon coated) being designed

5 Rail for handling in TA6

Plus some more civil engineering (floor) underground

# EYETS 2016-2017 main activities

1 Supporting structures in BA6/

Integrated with the reinforcement project steered by HSE and SMB. In EYETS, must come before cabling

2 Cables/ RF waveguides

Uncabling 4.8km  
Routing under false floor and shaft

3 Cryogenic distribution line installation

Installed by contractor, routed at the tunnel vault, 10m sections, requires scaffolding and welding in the tunnel.  
4 weeks

4 Vacuum layout modification

Vacuum chambers (carbon coated) being fabricated

5 Rail for handling in TA6

Plus some more civil engineering (floor) underground

# 61693 to 61710

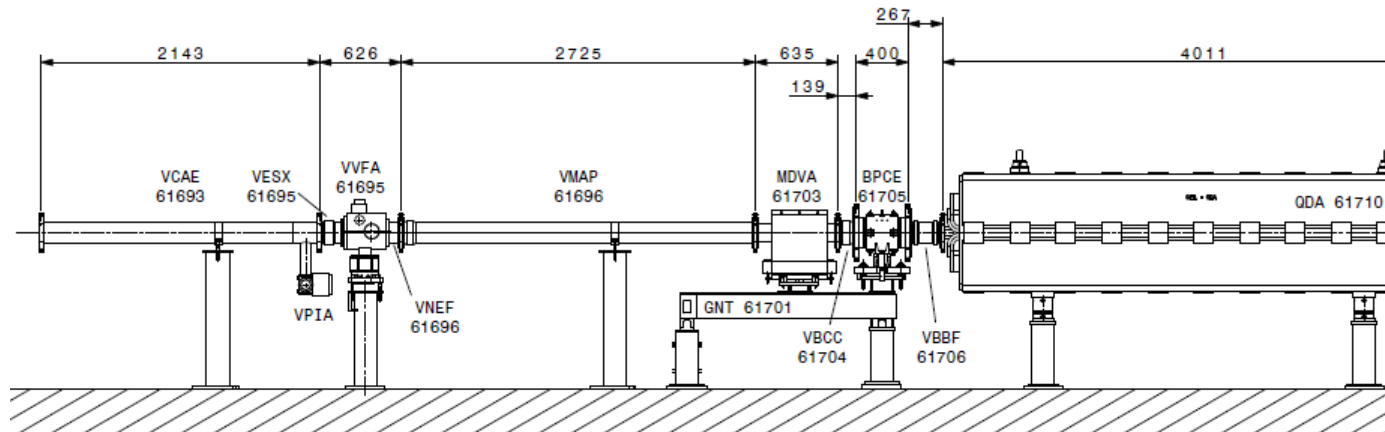
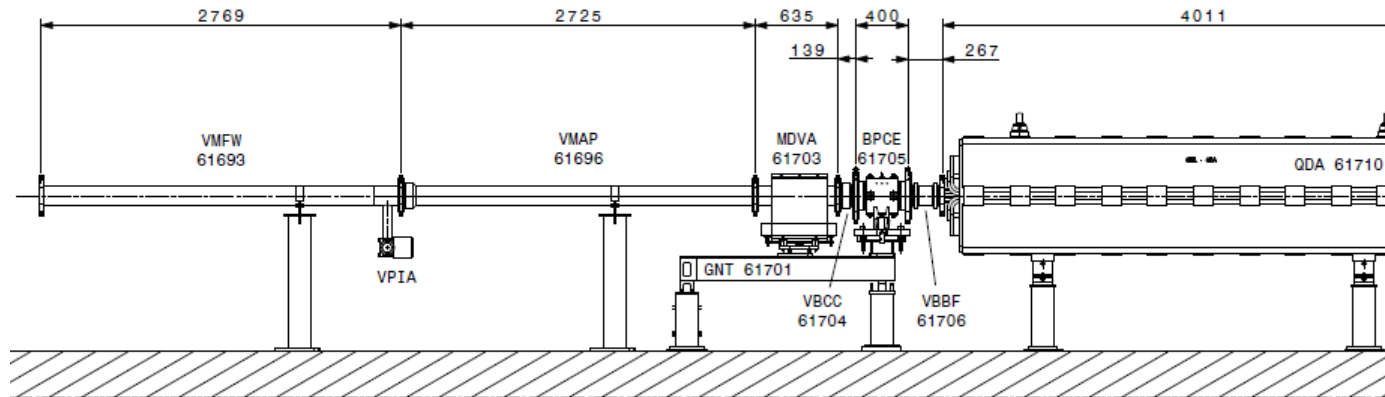

# 61710 to 61773

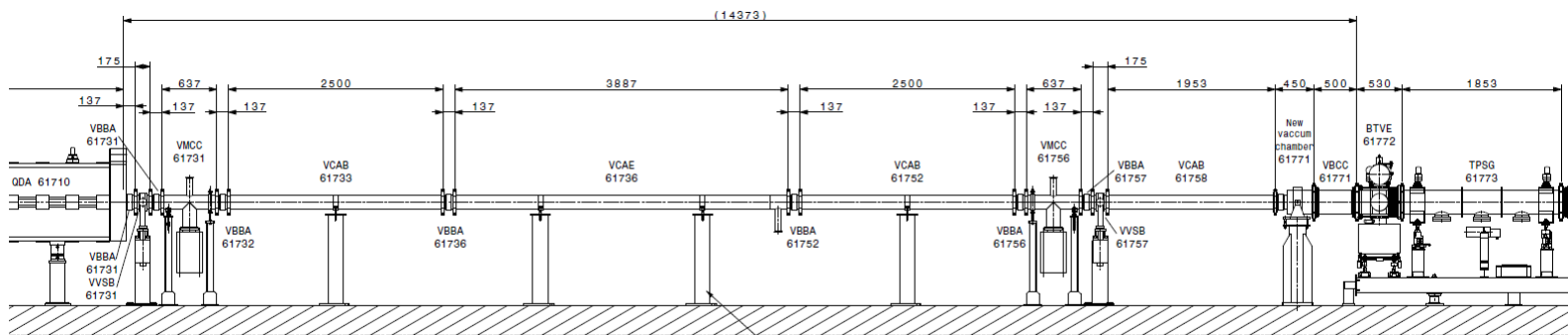
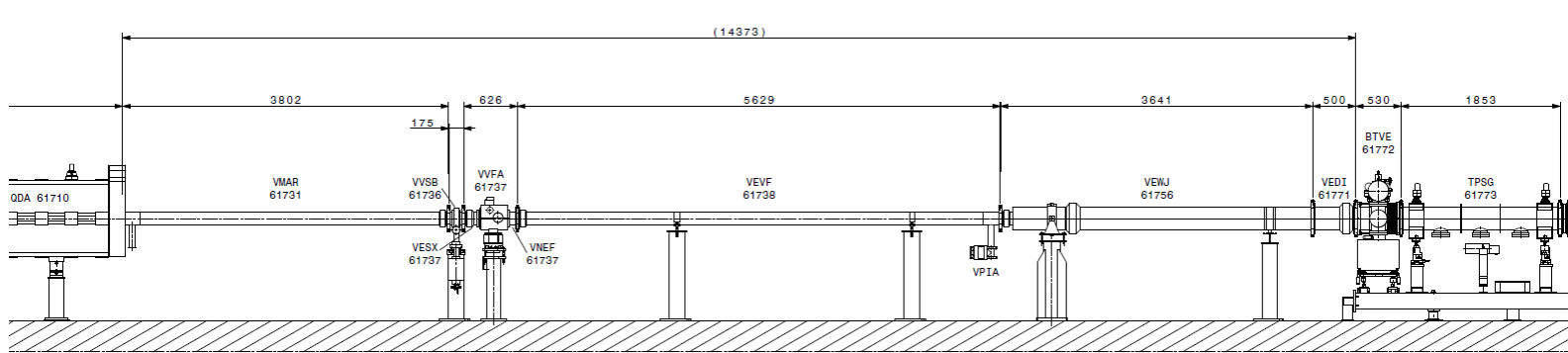

L'emplacement des supports reste à définir



# Future layout

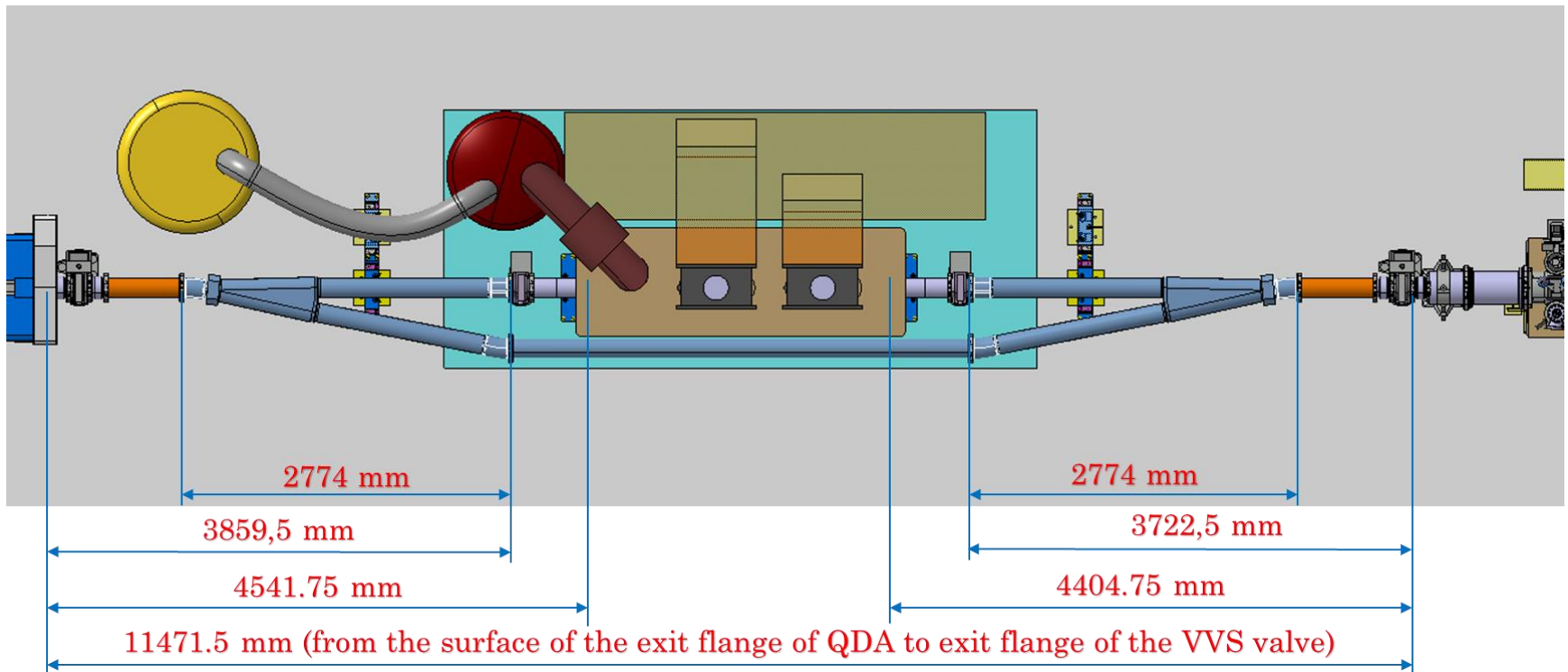

# 61710 to 61773

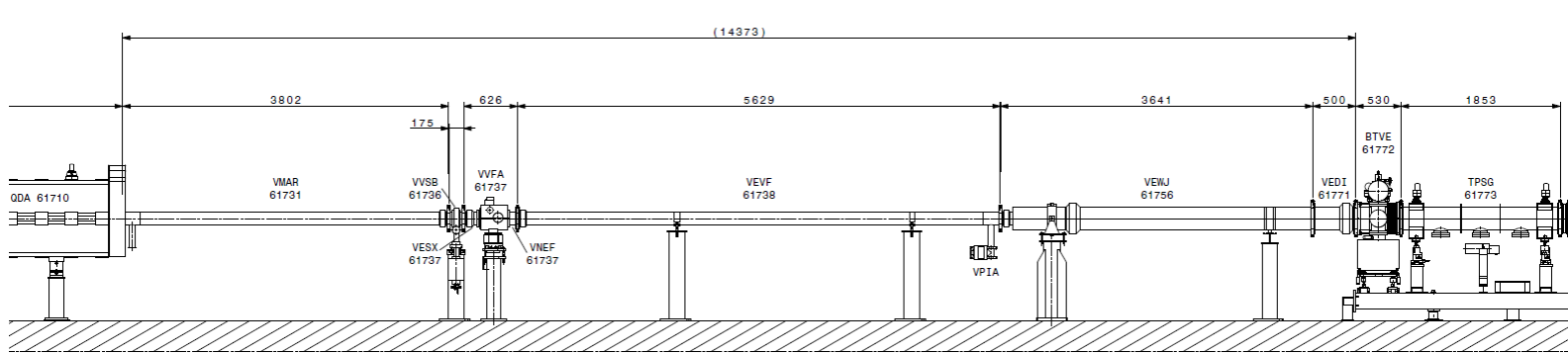

Y-chamber location

Y-chamber location

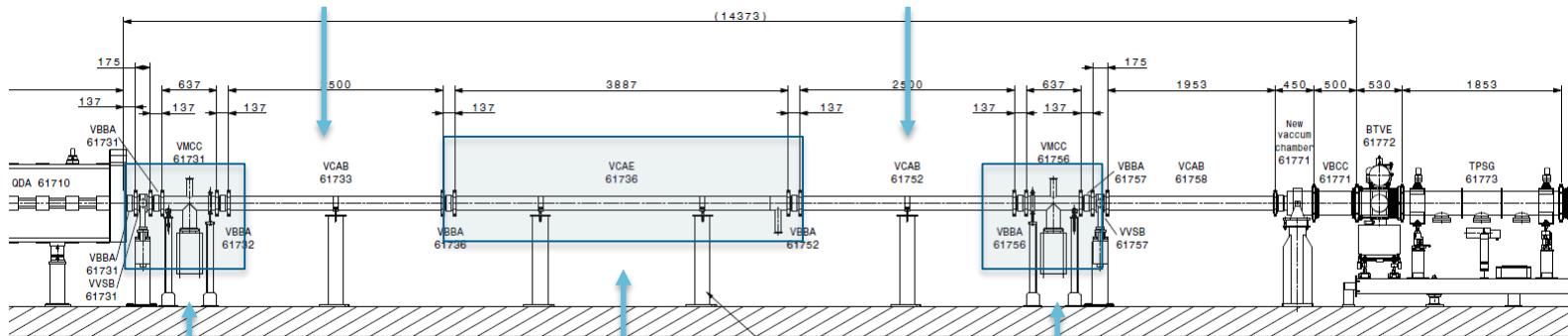

L'emplacement des supports reste à définir

Pumping module  
+VVS

Future by-pass chamber

Pumping module  
+VVS

# 61710 to 61773

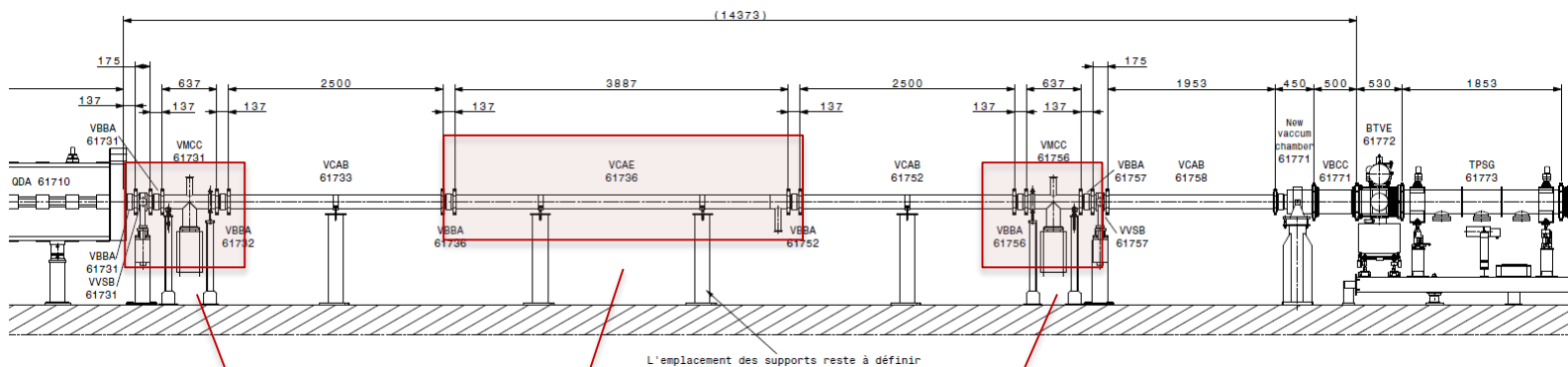
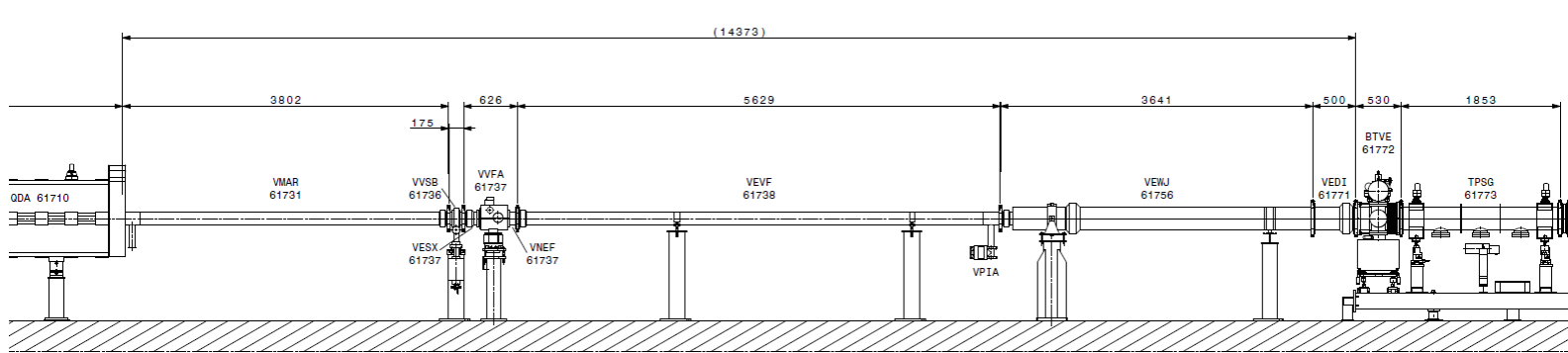

Carbon coating, to reduce dynamic gas load by multipacting to the Crab Cavities vacuum requirements

# New TPSG after LS2

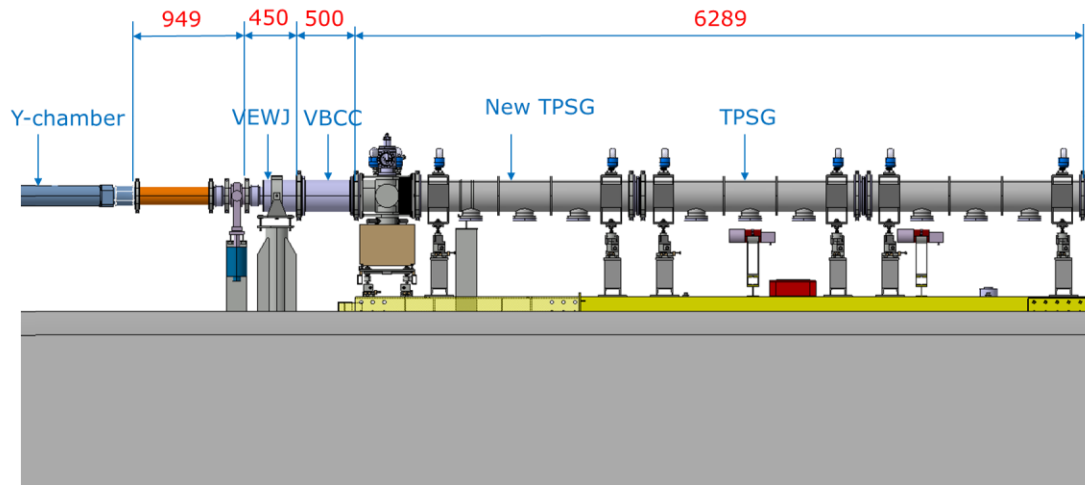
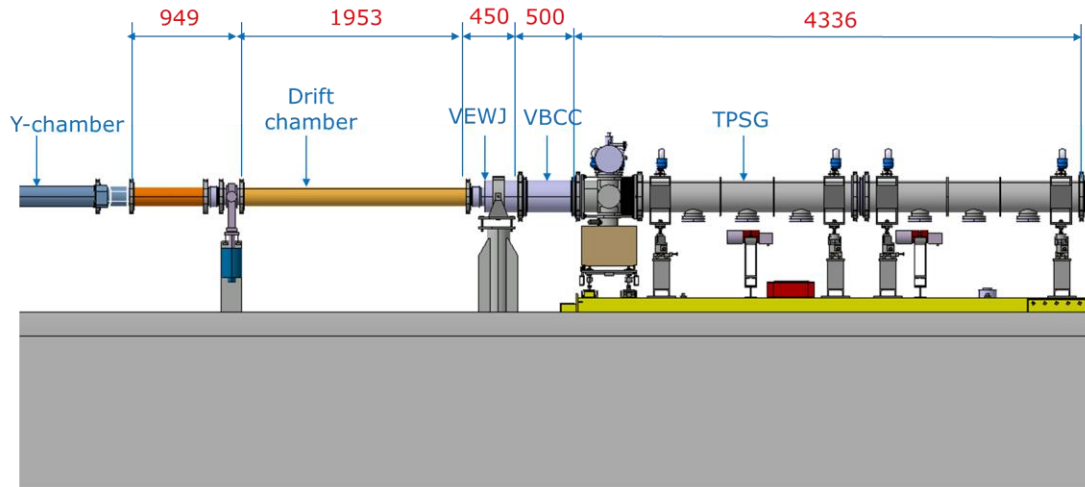

Jan 2018

After LS2

# New TPSG after LS2

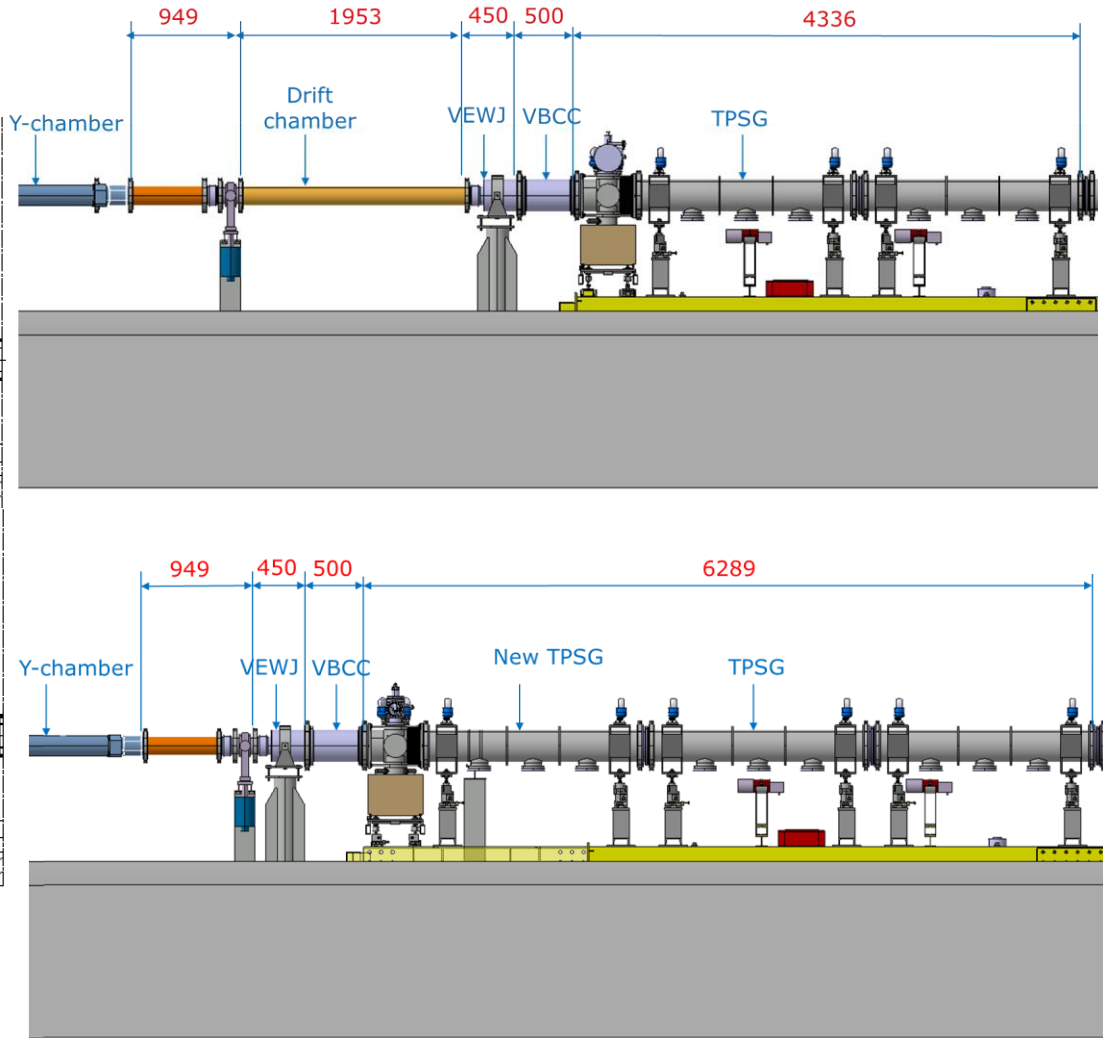
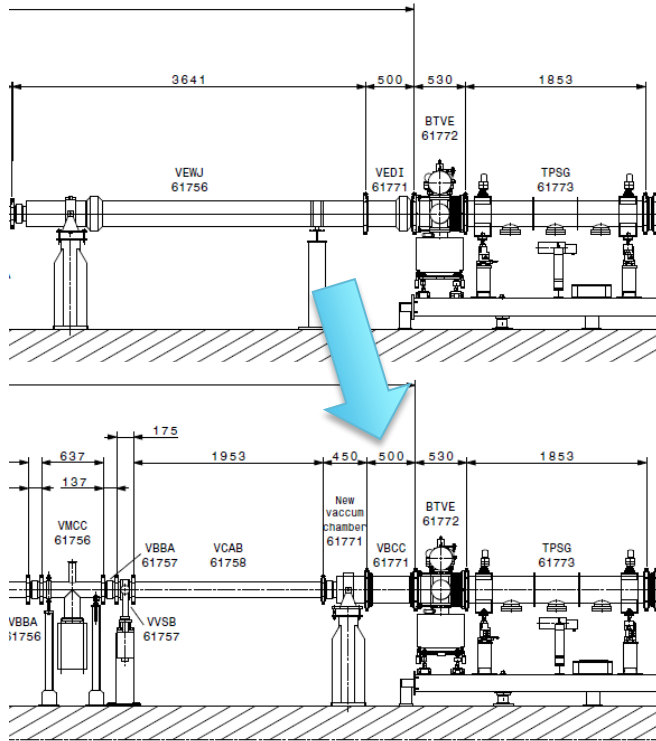

Jan 2018

After LS2

See [EDMS 1604149](#)

# Tunnel vault: new cryogenic distribution line

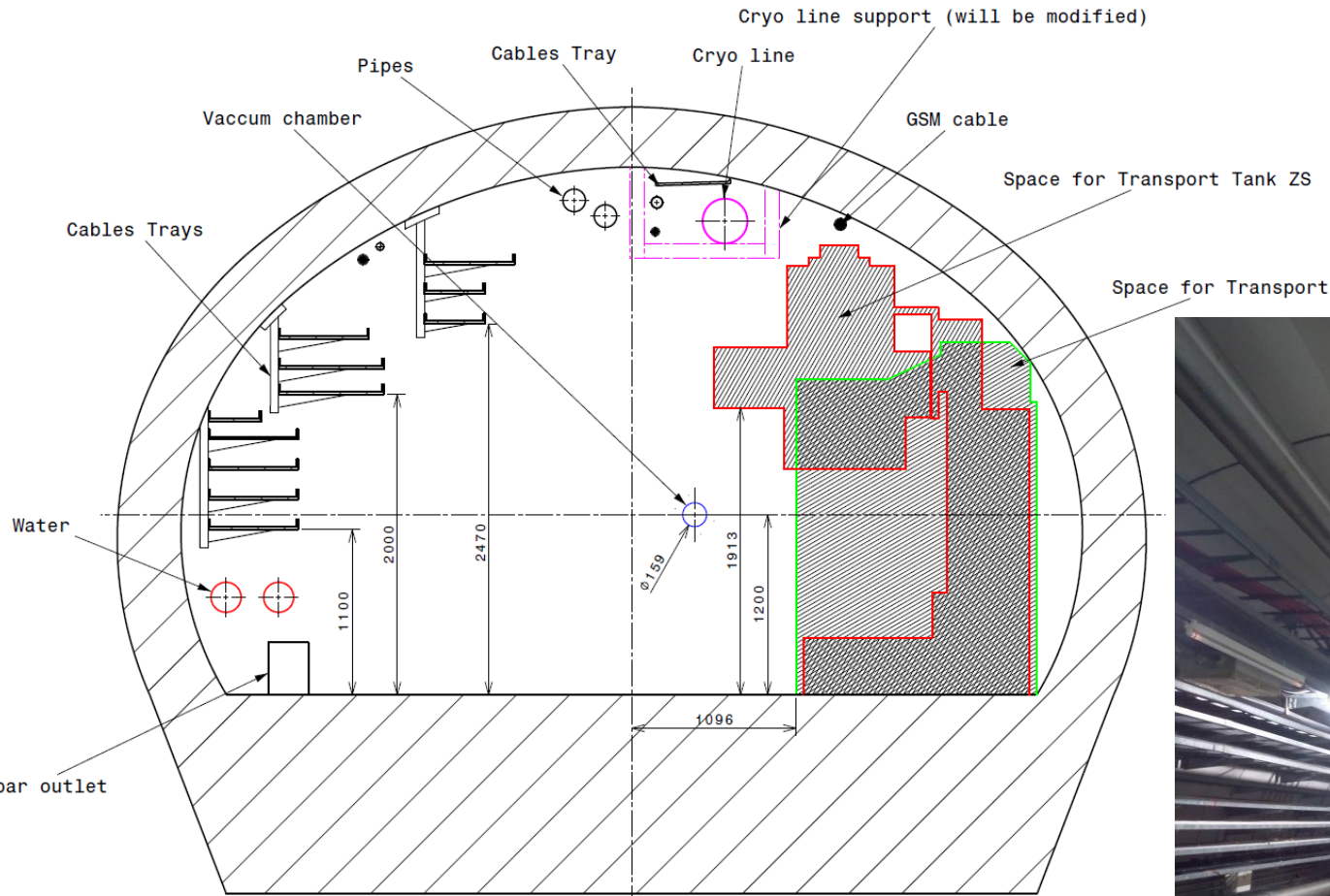

# Tunnel vault: new cryogenic distribution line

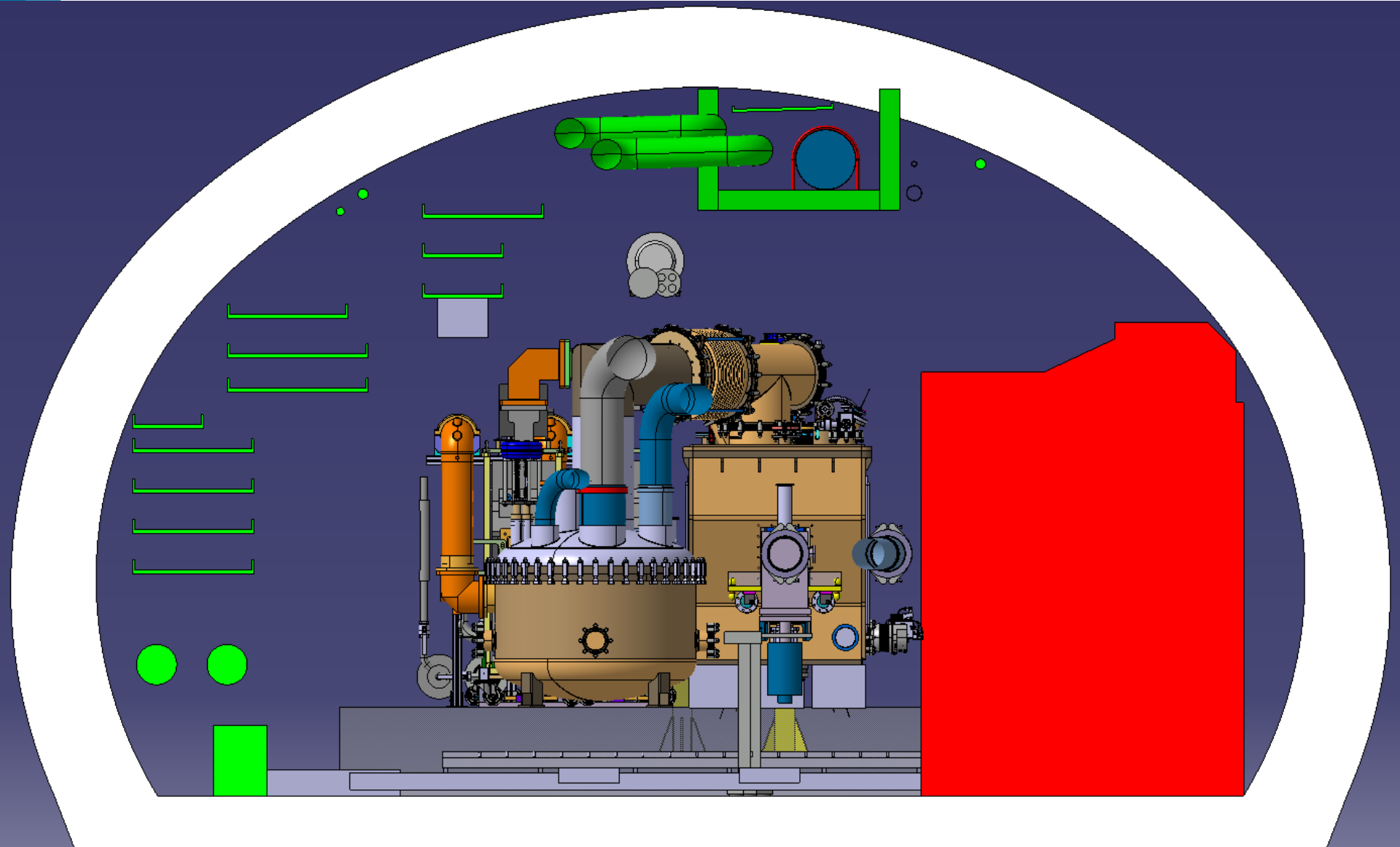

# Installation of handling rails in TA6

And removal of the blue mezzanine structure

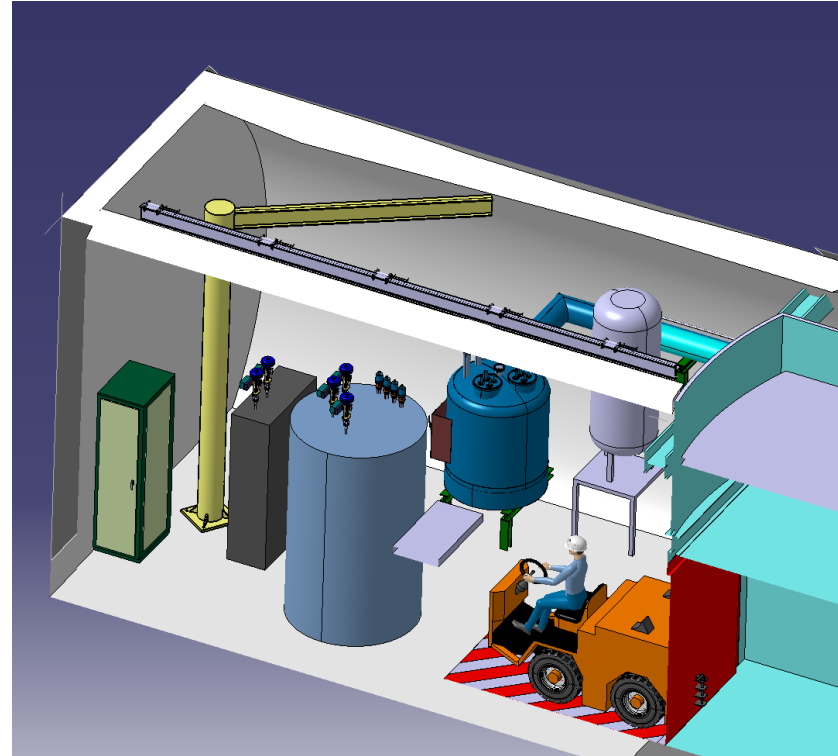



# Comments

L.Rossi: Have HL-LHC appear in the title

TE-CRG, EN-HE, EN-CV: Colleagues give or request more details on detailed integration of the cryogenic distribution line

BE-RF, TE-VSC: Discussion on the necessity to have the (standard) sectorization valves provided with RF fingers for impedance reduction.

**No blocking comments**

# ECRs to come

BA6	Layout and floor reinforcement	Sep 16
LSS6	Complete crab cavity installation	May 17

**Thank you**