



P-GRADE Portal tutorial part 1.:

Managing workflow applications on EGEE

Miklos Kozlovsky

MTA SZTAKI

m.kozlovsky@sztaki.hu

www.portal.p-grade.hu

pgportal@lpds.sztaki.hu



P-GRADE |
portal



- P-GRADE Portal in a nutshell
- Workflow development with P-GRADE Portal
- Workflow execution with P-GRADE Portal

Family of P-GRADE Portal products

- P-GRADE portal
 - Creating (basic) workflows and parameter sweeps for service grids
 - www.portal.p-grade.hu
- P-GRADE/GEMLCA portal (University of Westminster)
 - To wrap legacy applications into Grid Services
 - To add legacy code services to P-GRADE Portal workflows
 - <http://www.cpc.wmin.ac.uk/cpcsite/gemlca>
- WS-PGRADE
 - Creating complex workflow and parameter sweeps for clusters, service grids and desktop grids
 - Creating complex applications using embedded workflows, legacy codes and community components from workflow repository
 - www.wspgrade.hu

References and P-GRADE installations

- P-GRADE Portal service is available for

- SEE-GRID-SCI infrastructure

- Central European VO of EGEE

- GILDA: Training VO of EGEE

- Many national Grids (UK National Grid Service, GridIreland, Turkish Grid, Croatian Grid, etc.)

- US Open Science Grid

- Economy-Grid, Swiss BioGrid, Bio and Biomed EGEE VOs, BioInfoGrid, BalticGrid

- GIN VO of OGF

- EGEE Respect program tool

- Total:

- 12 community installations, connection to ~20 grids

- ~1200 additional downloads from Sourceforge

- Developers from: UK, Turkey, Croatia, Italy, France

<http://portal.p-grade.hu/?m=installations&s=0>

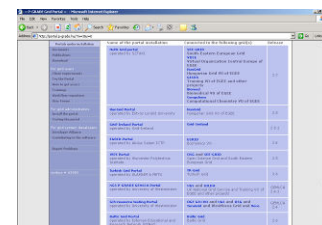
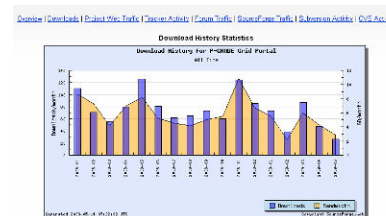

Some applications/services based on P-GRADE Portal

- Molecular Dynamics Study of Water Penetration (CHARMM): Parametric workflow resulting hundreds of long running jobs
 - <http://wgrass.wmin.ac.uk/index.php/W-Grass:autodock>
- R: Patient Readmission Analysis
 - <http://wgrass.wmin.ac.uk/index.php/W-Grass:r>
- In Silico Modelling using Autodock
 - <http://wgrass.wmin.ac.uk/index.php/W-Grass:autodock>
- MultiBayes – DNA sequence analyzer application
- GAMESS-UK - ab initio molecule structure analyzer application
- Minimizing operational cost of factories and logistic service providers (EMMIL): Parametric workflow resulting thousands of short running jobs
- Studying oscillons and magnetic monopole configurations: Parametric workflow resulting hundreds of short running jobs
- Ultra short range weather forecast (MEANDER): workflow that integrates 4 meteorological algorithms and one visualizer component

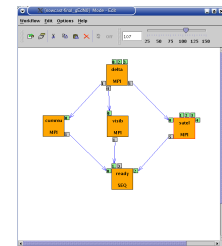
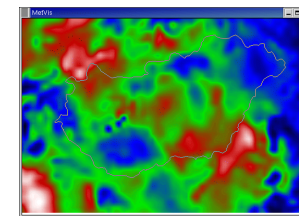
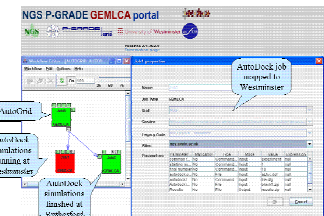
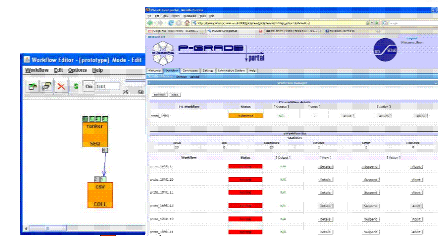
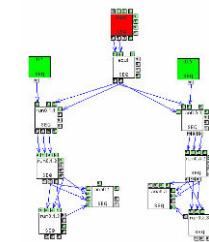

Application Specific Portals

The Rendering Portal

Contact: Mr. Tamas Kiss, kisst@wmin.ac.uk

Create a new rendering job by uploading file to be rendered

Download rendered images

Submit workflow

RELEASE 2.5



Rendering

New rendering job | Manage rendering jobs | Help

Upload file from local pc

File Upload

Look in: EGEE 07 demo

- ~\$EE07 UoW demos
- Document Scrap 'http__mut_cpc_w...'
- EGEE07 UoW demos
- GEMLCA_EGEE2007Conf
- knight.blend
- knight-fast.blend
- longer.blend
- lostride.blend

Workflow Manager

Refresh

Workflow	Status	Size	Quota (100 Mb)	[Output]	[View]
Ball	finished	220 KB	0.22%	<input checked="" type="checkbox"/>	<input type="button" value="Details"/>
Knight	finished	1.17 MB	1.17%	<input checked="" type="checkbox"/>	<input type="button" value="Details"/>
Lostride	finished	11.175 MB	11.18%	<input checked="" type="checkbox"/>	<input type="button" value="Details"/>
Overall used quota:		12.561 MB	12.56%		

Application Specific Portals (contd.)

Supplier chain portal: EMMIL P-GRADE Procurement Portal

Set up the most optimal supplier chain

Log in as buyer, supplier, or logistic service provider. Create auctions or take your bids

Best buyer-seller-logistic service provider pairs discovered, result presented in an Excel file

Parameter study optimization workflow is automatically generated and executed

The screenshot displays the EMMIL P-Grade Procurement Portal interface. At the top, there are tabs for 'Welcome' and 'Emmil'. Below this, a table titled 'Available Auctions for Suppliers' lists auction details. A yellow callout box points to the 'Download finished Auction's results' button. Another yellow callout box points to the 'Available Auctions for Suppliers' table. A third yellow callout box points to an Excel spreadsheet showing the results of the auction. The Excel spreadsheet has columns for Product #, Quantity, Unit Price, Value of order, Delivery Variable Cost, and Price. A red circle highlights the 'TOTAL PRICE' cell, which contains the value 153088.56. A fourth yellow callout box points to a workflow diagram in the bottom left corner, which shows a sequence of steps: Generator, LP_solve, SEQ, and PriceEv... COLL. A red arrow points from the workflow diagram to the Excel spreadsheet, indicating that the optimization workflow is automatically generated and executed.

ID	Auction Adviser	Date/Time	Remaining Time	Number of Bids	Set Sup
0	Buyer_01	Fri Sep 28 13:49:51 CEST 2007	0 weeks, 6 days, 5 hours, 58minutes, 12 seconds	1	<input type="checkbox"/>

ID	Auction Adviser	Date/Time	Remaining Time
106	Supplier 4		
107			
108			
109			
110			
111			
112			
113			
114			
115			
116			
117			
118			
119			
120			

Product #	Quantity	Unit Price	Value of order	Delivery Variable Cost	Price
0	25	140.65	3516.26	209.34	3725.99523
3	70	19.14	1339.54	586.15	1925.689562
5	50	18.65	932.28	418.68	1350.952805
7	5	939.68	4698.39	41.87	4740.265005
8	50	39.15	1957.69	418.68	2376.370132
31	1	32.49	1007.12	259.58	1266.702419
3	130	19.14	2487.65	1088.55	3576.20147
4	100	25.95	2594.84	837.35	3432.187057
Summ Quantity	461	Container Number	5	Delivery Fix Cost per container	Delivery Fix Cost
				74.63	373.14
					Price for Supplier 4
					22767.09
					TOTAL PRICE 153088.56

Application Specific Portals (contd.)

EMMIL P-GRADE Procurement Portal

- Buyers profile
- Buyer's product management
- Buyer starts new auction
- Supplier places bid
- Supplier auction is closing
- 3PL places bid
- 3PL auction is closing

The screenshot displays the EMMIL P-Grade Procurement Portal interface. It features a navigation menu with options like 'Welcome', 'EMMIL', 'Help', 'Udvözöllek', 'Adminisztráció', and 'EMMIL'. The main content area is divided into several sections:

- Index Product Name:** A list of products including 23022CAW33, 21875BORE, and 2MM9108WICRDUL.
- Products Selection:** A table listing product details such as 'KSSN14C188' (1/4-20 Stainless) and 'KSSLW14188' (1/4 Stainless Ste).
- Index Buyer:** A table listing buyers like 'Acheron Disures', 'Miklos Lovasz Ltd', 'Janos & Sons Ltd', and 'T&G Company'.
- Index Required Quantity:** A table showing required quantities for products, such as 20 for product 1 and 10 for product 2.

WINNERS of the BIDDING PROCESS:

Supplier:	EGC_Super			
3PL	SPRSP_Logistics			
	Products	Quantity	Unit Price	Price
	SFEW38112188	40.00	290.00	11600
	SSCS1434C188	80.00	180.00	14400
	SRMS1212CP188	60.00	90.00	5400
	Totals:			31400
	Delivery	Variable price	Fix price	Cost of delivery
	Variable unit price	15	450	
	Quantity	180	2	
	Price	2700	900	3600
	Total cost from supplier			35000

Results

Index	Supplier Name	Fix Price
1	GLL Fixtures (details)	
2	HYS Allmaterials (details)	
3	IID Ironmonger (details)	
4	JBX PlusPlus (details)	

Supplier:	BHG_Machining			
3PL	SPRSP_Logistics			
	Products	Quantity	Unit Price	Price
	SRMS1234CP188	50.00	130.00	6500.00
	Delivery	Variable price	Fix price	Cost of delivery
	Variable unit price	15	250	
	Quantity	50	1	
	Price	750	250	1000
	Total cost from supplier			7500
	Grand Total Cost of procurement			42500

Place Bid

Available Auctions for 3PL

ID	Date/Time	Remaining Time	Products	Numb. of Supp.Bids	Numb. of 3PL.Bids	Supplier's Time	3PL's Time	Status
1	Sun Apr 13 17:31:59 CEST 2008	-2 days, 0 hours, -39minutes	(details)	(4)	(2)	24.0	24.0	3PL Close Auction
2	Sun Apr 13 14:55:43 CEST 2008	-2 days, -3 hours, -16minutes	(details)	(3)	(1)	24.0	24.0	3PL Close Auction

Current situation and trends in Grid computing

- Fast evolution of Grid systems and middleware:
 - **GT2, OGSA, GT3 (OGSI), GT4 (WSRF), LCG-2, gLite, ...**
- Many production Grid systems are built with them
 - EGEE (LCG-2 → gLite), UK NGS (GT2), Open Science Grid (GT2 → GT4), NorduGrid (~GT2)
- Although **the same set of core services** are available everywhere, they **are implemented in different ways**
 - Data services
 - Computation services
 - Security services (single sign-on)
 - (Brokers)

P-GRADE Portal in a nutshell

- **General purpose, workflow-oriented computational Grid portal.** Supports the development and execution of workflow-based Grid applications – **a tool for Grid orchestration**
- **Based on GridSphere-2**
 - Easy to expand with new portlets (e.g. application-specific portlets)
 - Easy to tailor to end-user needs
- **Grid services** supported by the portal:

Service	EGEE grids	Globus grids
Job execution	Computing Element	GRAM
File storage	Storage Element	GridFTP server
Certificate management	MyProxy	
Information system	BDII	MDS-2, MDS-4
Brokering	Workload Management System	GTbroker
Job monitoring	Mercury	
Workflow & job visualization	PROVE	

Solves Grid interoperability problem at the workflow level

The typical user scenario

Part 1 - development phase

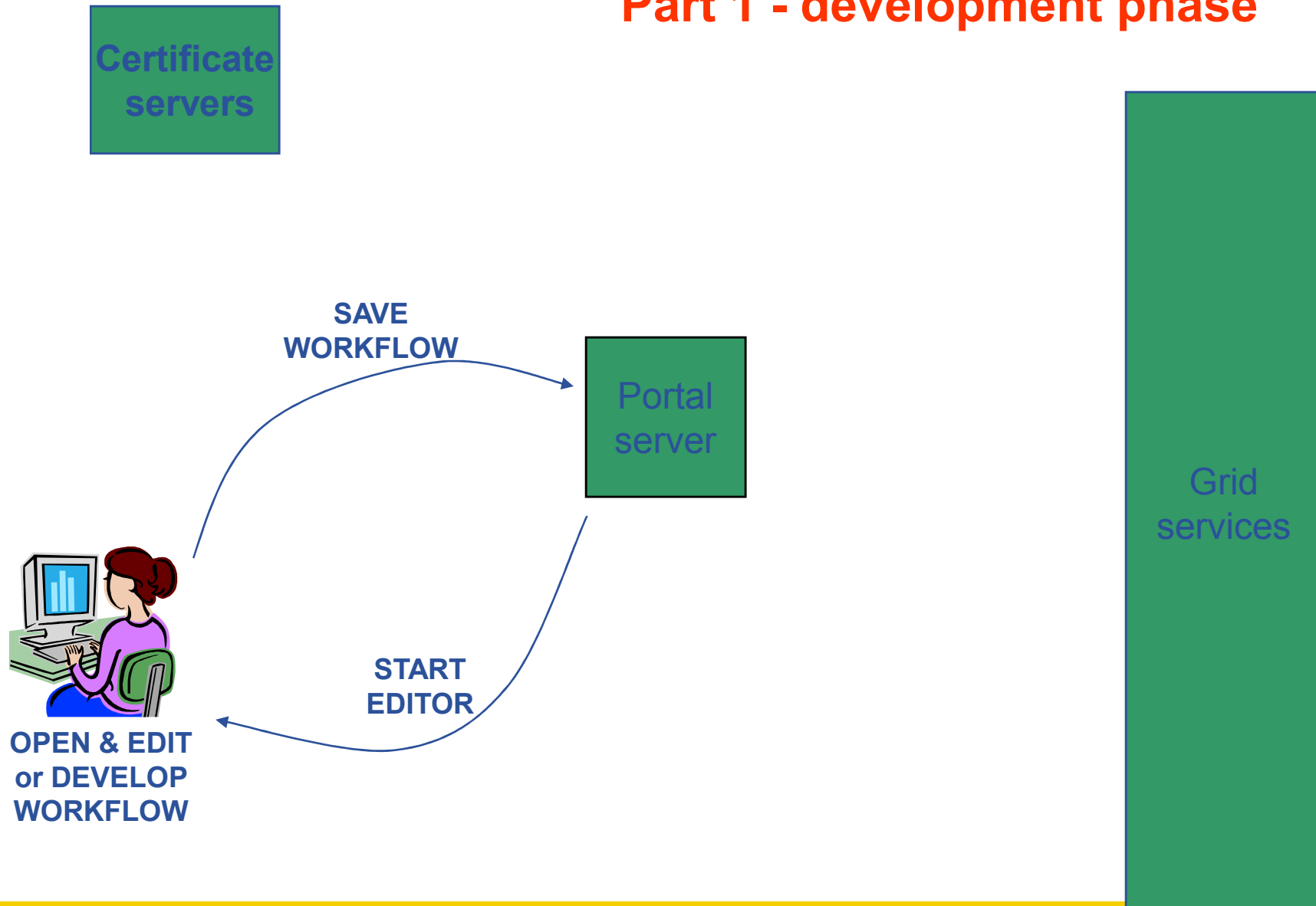

The typical user scenario

Part 2 - execution phase

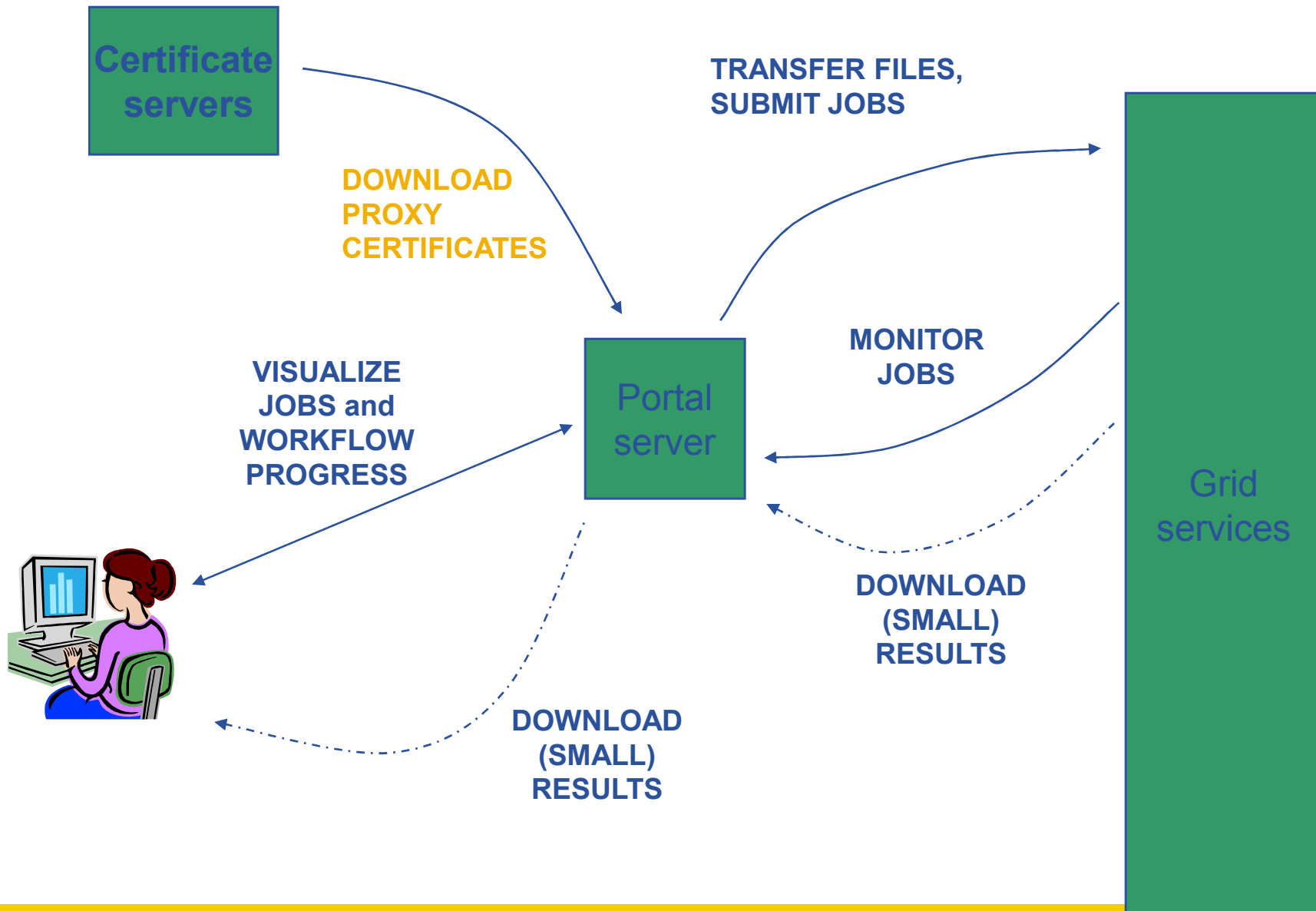

Defining workflow with the P-GRADE Portal

Main steps

1. Define workflow structure
2. Define binaries & setup parameters and properties (JDL)
3. Define resource selection
4. Setup In/Outputs
5. Create or upload file/directory structure on SE (optional)
6. Name & Save the workflow (Upload binaries, and other files)

What is a P-GRADE Portal workflow?

- **a directed acyclic graph where**
 - Nodes represent jobs (batch programs to be executed on a computing element)
 - Ports represent input/output files the jobs expect/produce
 - Arcs represent file transfer operations
- **semantics of the workflow:**
 - A job can be executed if all of its input files are available

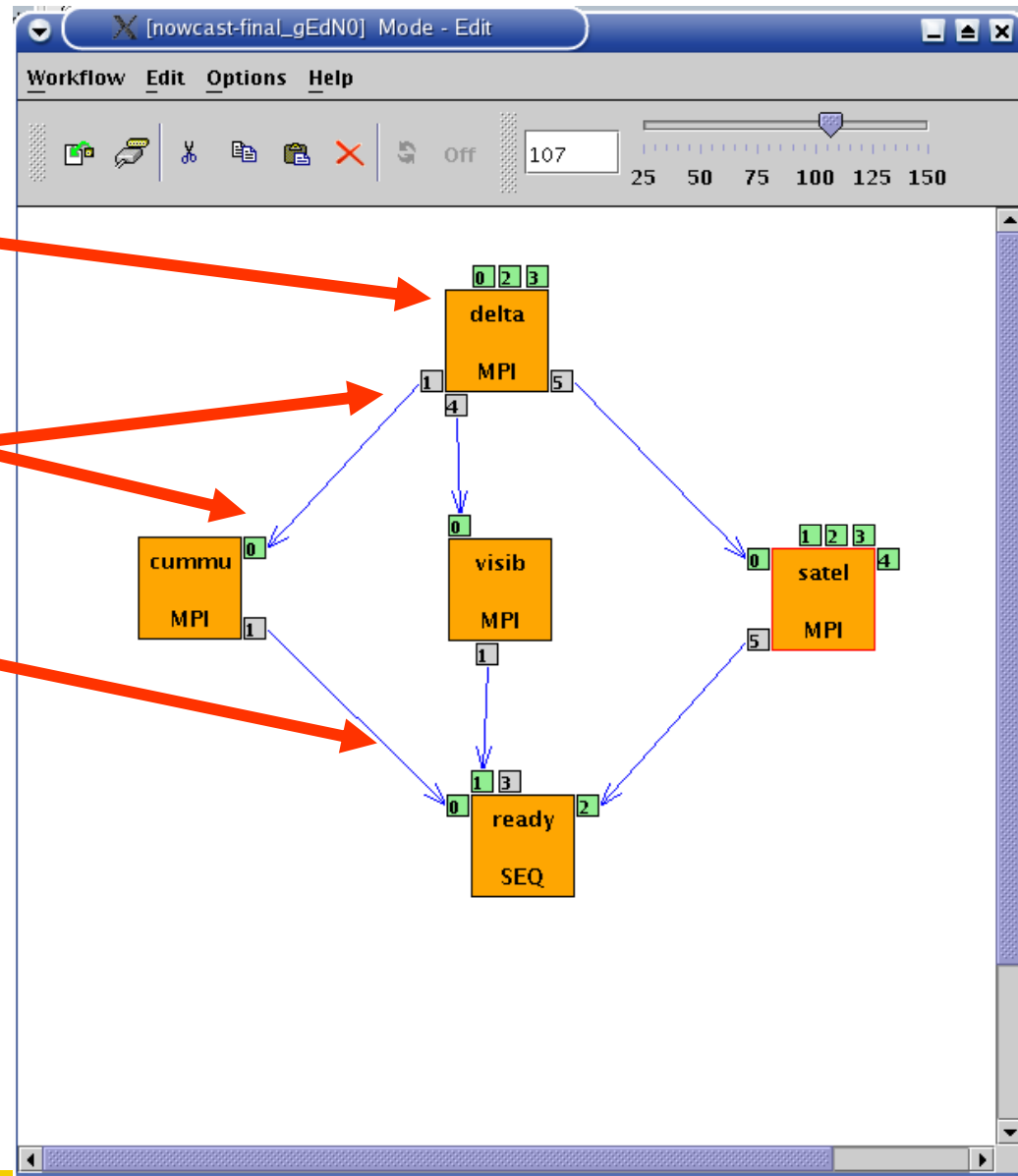

Two levels of parallelism by a workflow

- The workflow concept of the P-
GRADE Portal enables the
efficient parallelization of
complex problems
- Semantics of the workflow
enables two levels of
parallelism:

– Parallel execution
inside a workflow
node

– Parallel execution
among workflow
nodes

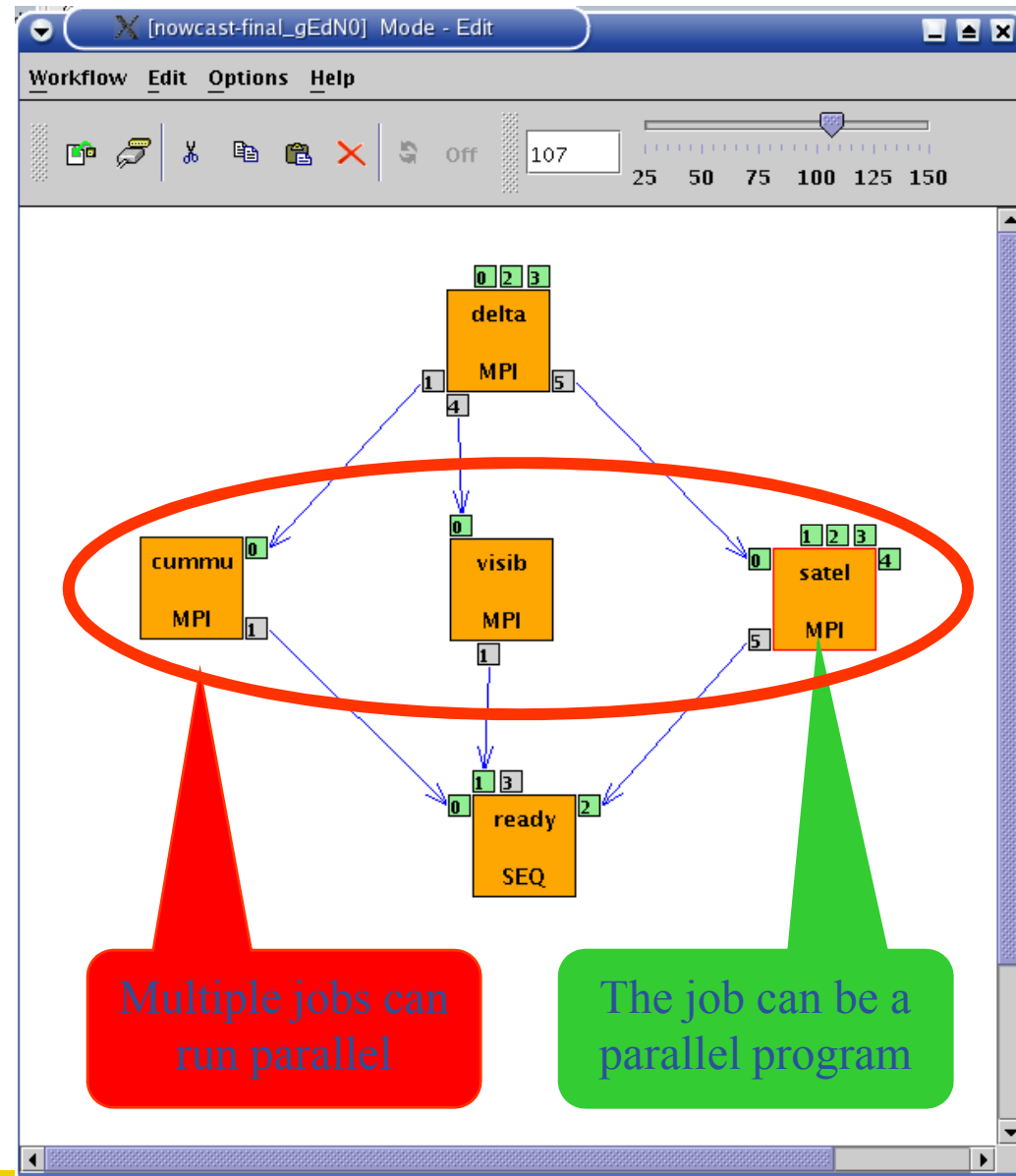

Ultra-short range weather forecast (Hungarian Meteorology Service)

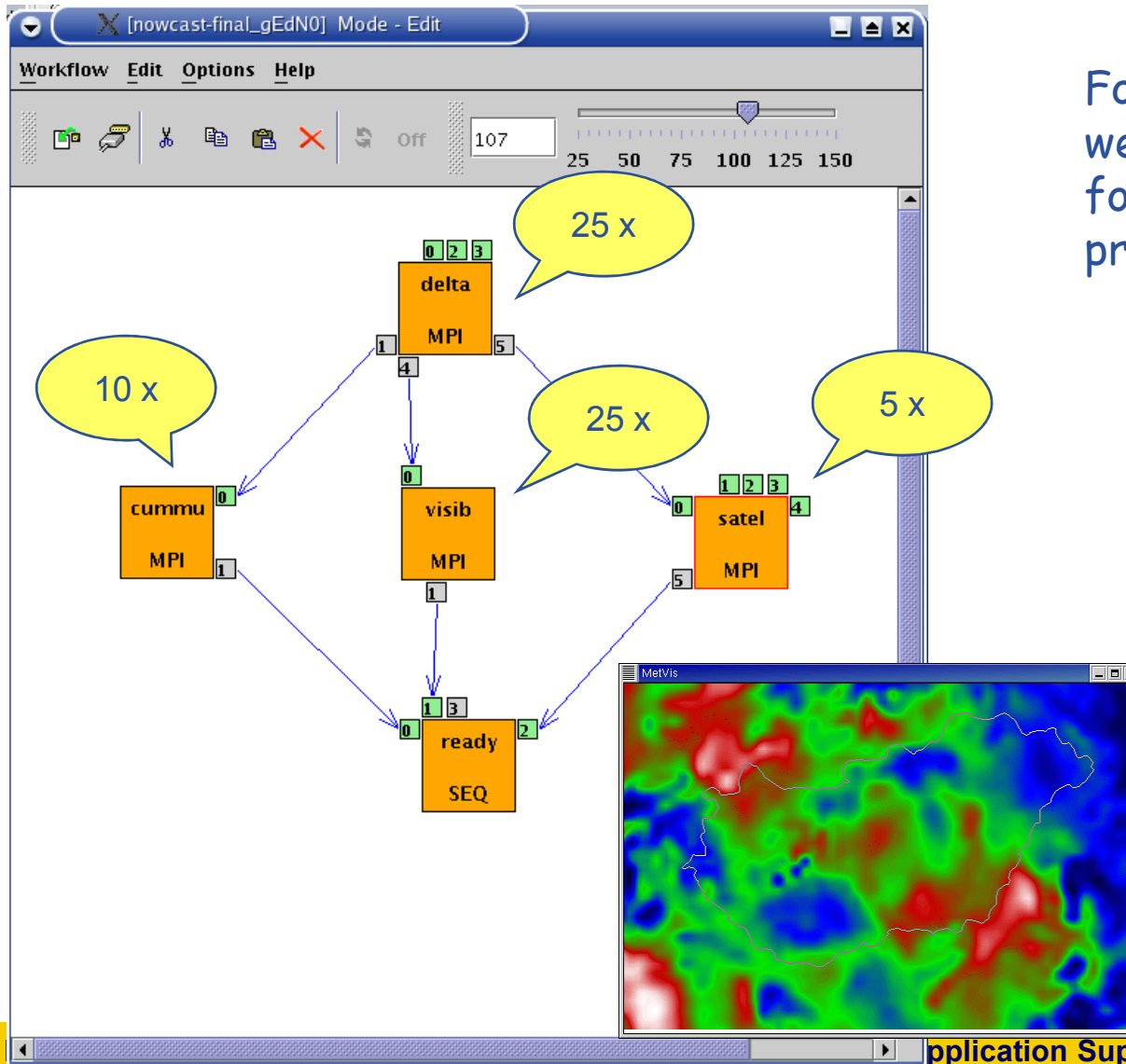

Forecasting dangerous weather situations (storms, fog, etc.), crucial task in the protection of life and property

Processed information: surface level measurements, high-altitude measurements, radar, satellite, lightning, results of previous computed models

Requirements:

- Execution time < 10 min
- High resolution (1km)

The typical user scenario

Development phase:

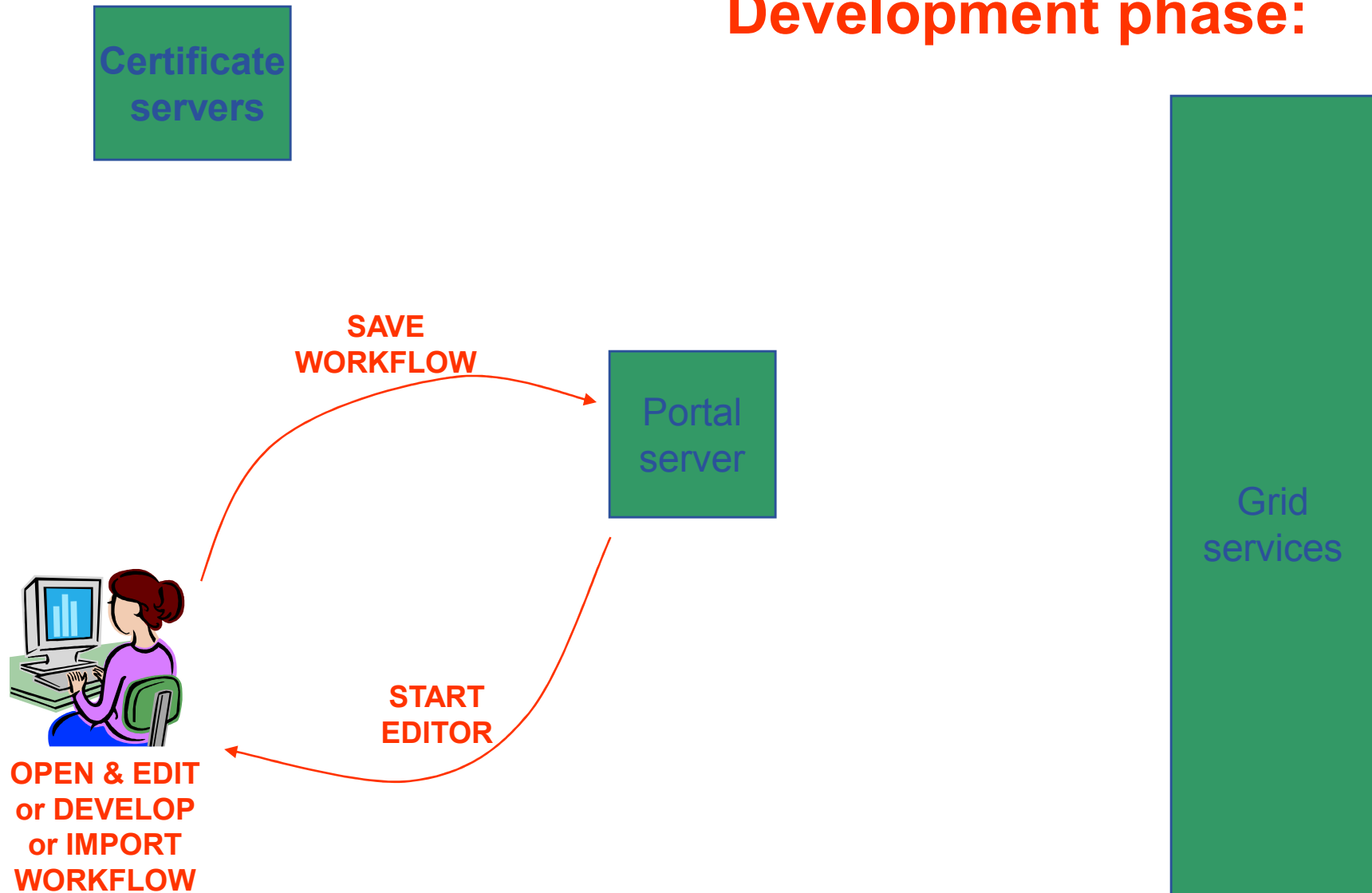

Workflow development

Opening the workflow editor

The editor is a Java Webstart application



download and installation is only one click!

The screenshot shows a web browser window displaying the P-Grade Portal. The main content area features the P-Grade logo, a 'portal' link with a downward arrow, and logos for the European Union, SEE-GRID, and VTI. Below this is a 'Workflow Manager' window with a 'Workflow Editor' tab and a 'Refresh' button. A table lists workflow details:

Workflow	Status	Size	Quota (100 Mb)	[Output]	[View]	[Action]
LM_9_DEMO_TOTAL	submitted	26,848 MB	26%	N/A	Details	Abort Attach Delete
		26,848 MB	26%			

A message at the bottom of the window reads: **Message: Workflow successfully submitted.**

Workflow Editor

Defining the graph

- The aim is to define a DAG of batch jobs:
 - Drag & drop components:** jobs and ports
 - Define their properties**
 - Connect ports by channels**
(no cycles, no loops, no conditions)

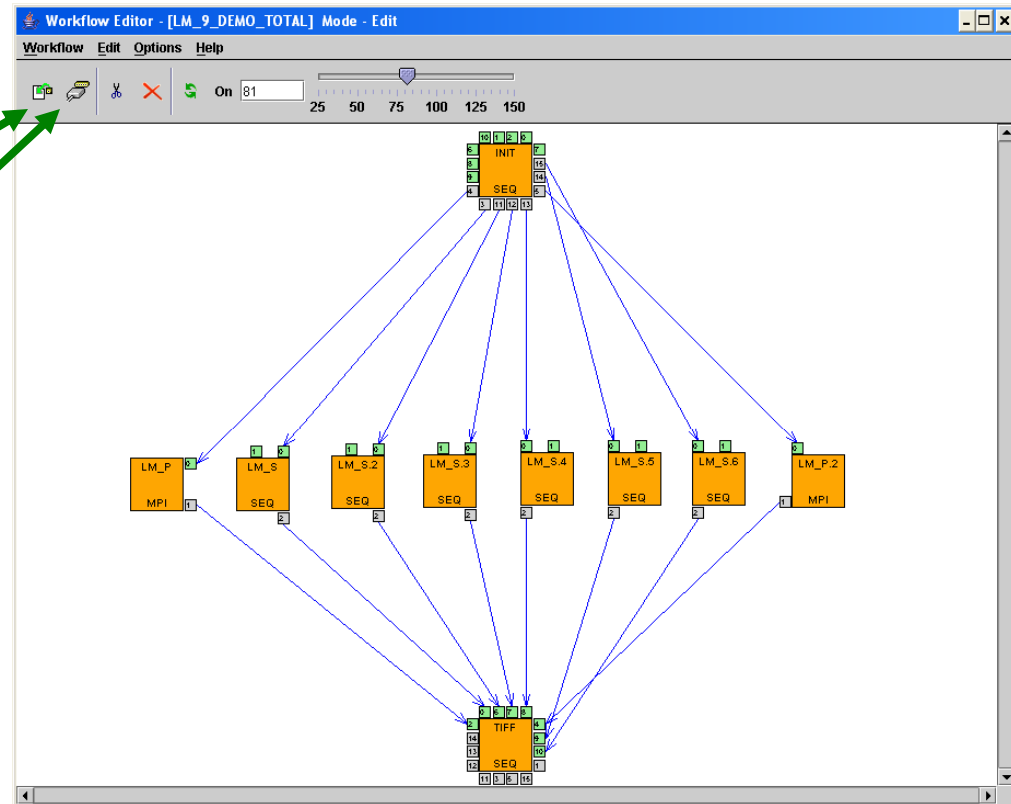

Workflow Editor

Properties of a job

Workflow Editor - [LM_9_DEMO_TOTAL] Mode - Edit

Workflow Edit Options Help

LM_P properties

Name: LM_P

Job Type: SEQ MPI PVM

Job Executable: LM_5.bin

File Browser

Instrument

Process Number: 7

Attributes: -n -m

Grid: SEE-GRID

Monitor:

Resource: n40.hpcc.sztaki.hu:jobmanager-fork
ce01.grid.acad.bg:jobmanager-fork
grid-ce.ii.edu.mk:jobmanager-fork
grid1.irb.hr:jobmanager-fork
grid1.netmode.ece.ntua.gr:jobmanager-fork
n40.hpcc.sztaki.hu:jobmanager-fork
prof.salla6.inima.al:jobmanager-fork

Properties of a job:

- Binary executable
- Type of executable
- Number of required processors
- Command line parameters
- The resource to be used for the execution:
 - Grid/VO
 - (Computing element)

Direct resource selection:

Which computing element to use?

I still don't know which resource to use!

The information system portlet queries BDII and GIIS servers

PGrade Portal - Microsoft Internet Explorer

http://hgportal.hpcc.sztaki.hu:7080/gridsphere/gridsphere?action=doCh

Grid: SEE-GRID VO: seegrid

	Computing Element						Storage Element				
	CPU		Job			Space					
	Free	Usage	Running	Waiting	Load	Total	Available	Usage			
	80		29%	7	0		0%	226.793 GB	216.34 GB		5%
AEGIS02-RCUB	20		0%	0	0		0%	398.466 GB	396.58 GB		0%
BG01-IPP	54		67%	4	0		0%	609.554 GB	473.543 GB		22%
BG02-IM	20		20%	1	0		0%	131.775 GB	79.957 GB		39%
BG03-IPP-N	3		0%	0	0		0%	566.608 GB	566.376 GB		0%
BG04-ACAD	48		33%	2	5		71%	554.647 GB	475.767 GB		14%
HR-01-RBI	60		80%	4	0		0%	78.317 GB	6.271 GB		92%
MK-01-UKIM_II	28		0%	0	0		0%	69.709 GB	69.075 GB		1%
RO-01-ICI	54		56%	5	36		88%	849.666 GB	828.387 GB		3%
ROGRID-NIPNE-01	24		0%	0	0		0%	862.807 GB	848.676 GB		2%
SZTAKI	4		0%	0	0		0%	4.566 GB	2.871 GB		37%
tubitakcg2	35		20%	1	0		0%	1.335 TB	1.335 TB		0%



Automatic resource selection

1. Select a broker Grid/VO for the job
(e.g. GILDA_LCG2_broker/GILDA_gLite_broker)
2. (Describe the ranks & requirements of the job in JDL)
3. The portal will use the broker to find the best resource for the job!

Defining broker jobs

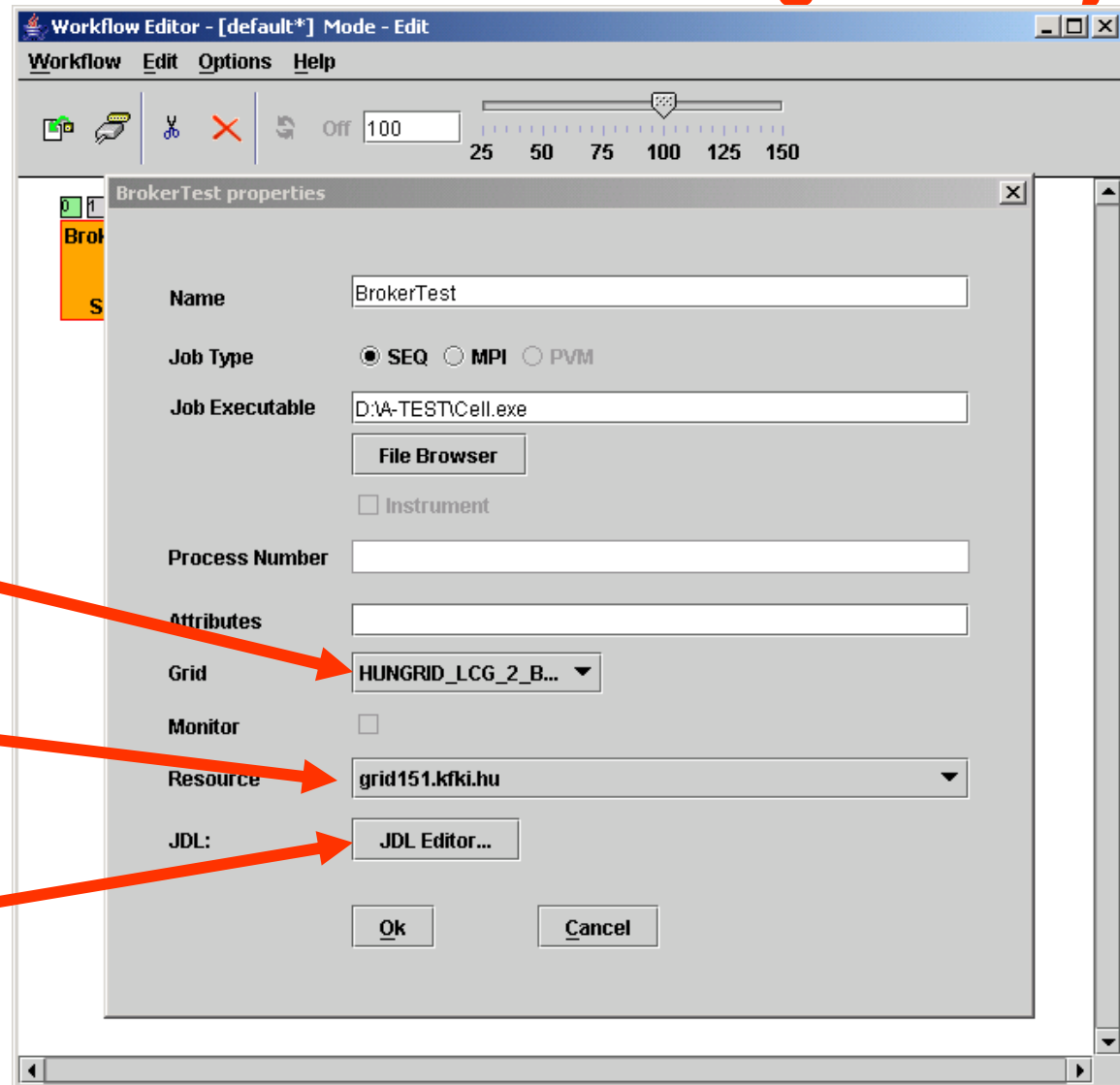

Select a Grid with broker!
(*_BROKER)

Ignore the resource field!

If default JDL is not sufficient
use the built-in JDL editor!

Workflow Editor

Built-in JDL editor

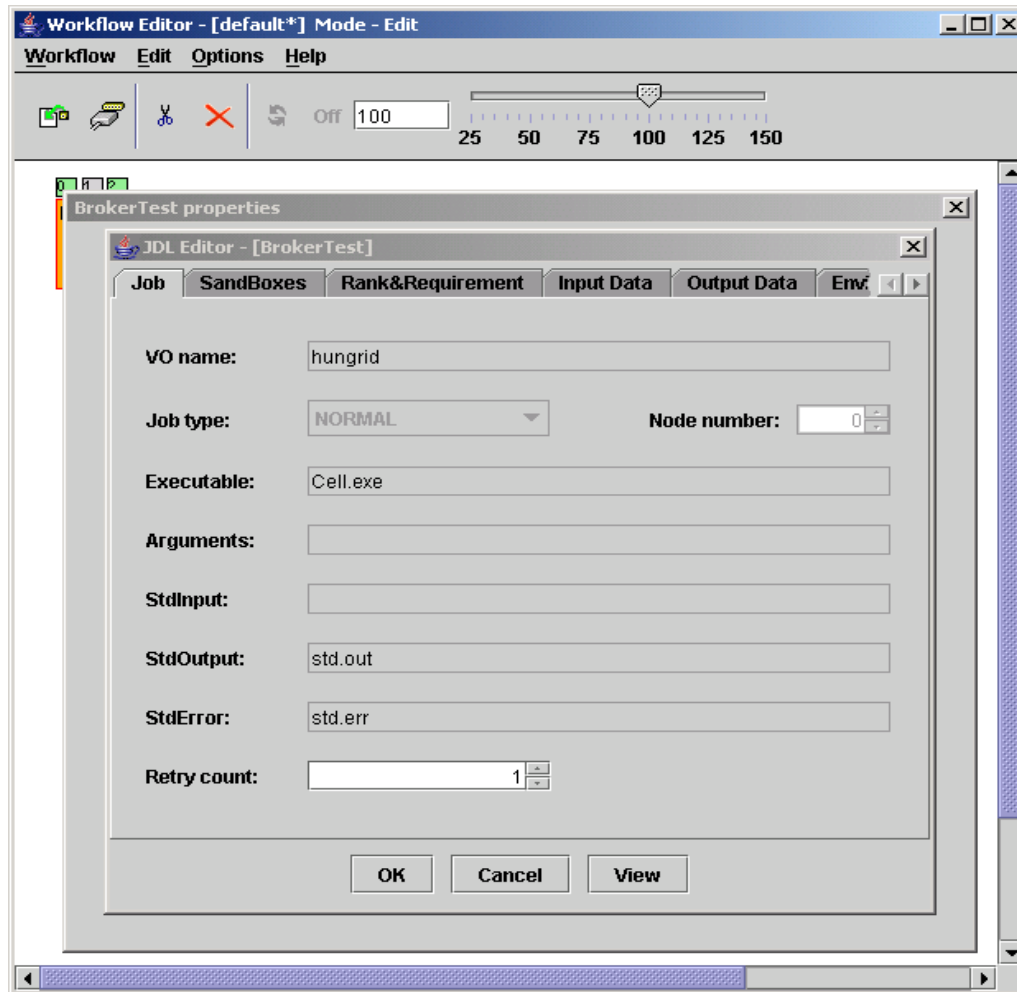

JDL → look at the gLite Users' manual!

Defining input-output files

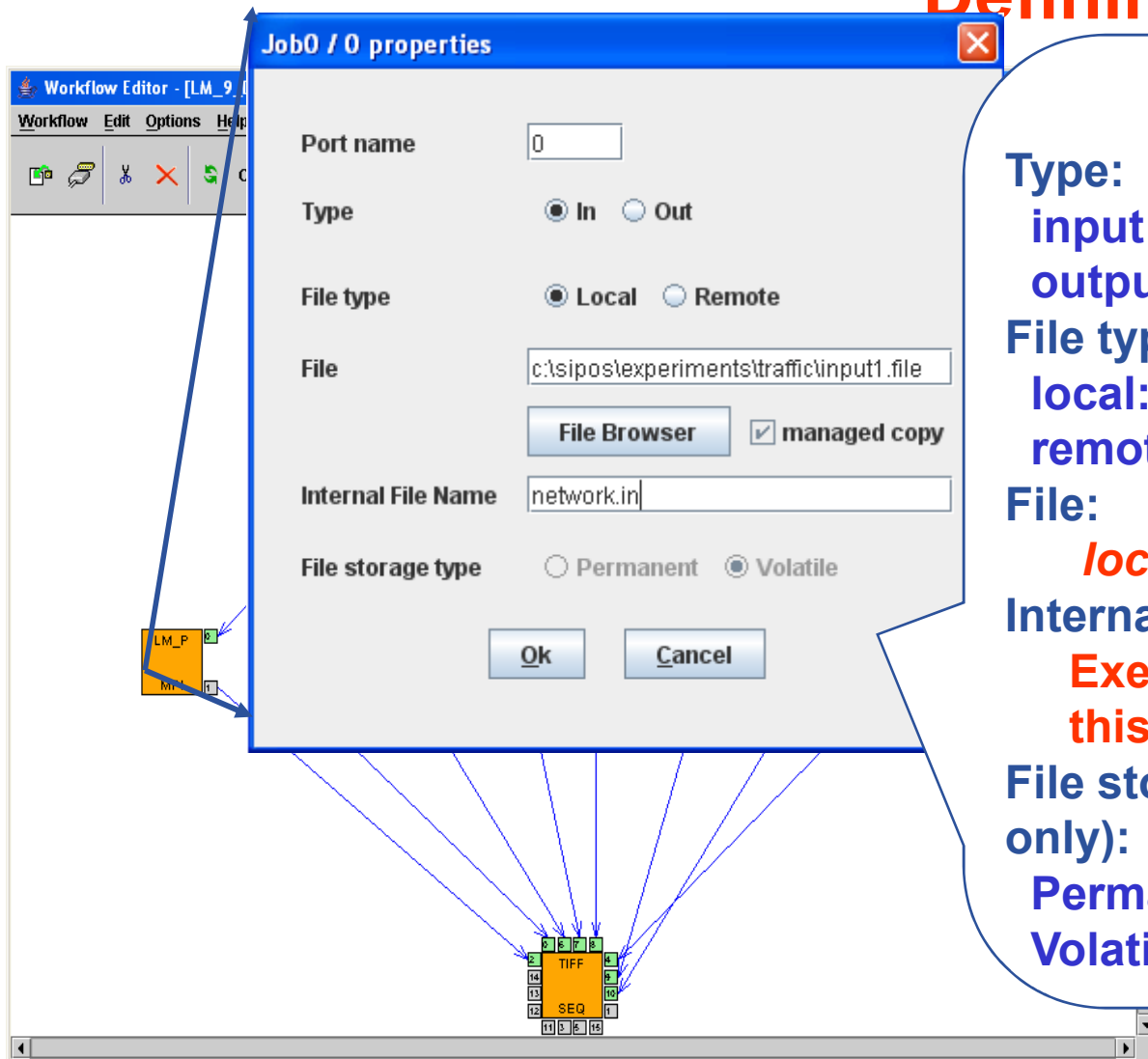

File properties

Type:

input: *the job reads*

output: *the job generates*

File type:

local: *comes from my desktop*

remote: *comes from an SE*

File:

location of the file

Internal file name:

Executable reads the file in this name – fopen("file.in", ...)

File storage type (output files only):

Permanent: *final result*

Volatile: *only data channel*

How to refer to an I/O file?

Input file

Output file

Local file

- Client side location:
c:\experiments\11-04.dat

- Client side location:
result.dat

- LFC logical file name
lfn:/grid/gilda/kozlovszky/11-04.dat

- LFC logical file name
lfn:/grid/gilda/kozlovszky/11-04_-_result.dat

Remote file

Local vs. remote files

Your jobs can access storage files directly too!

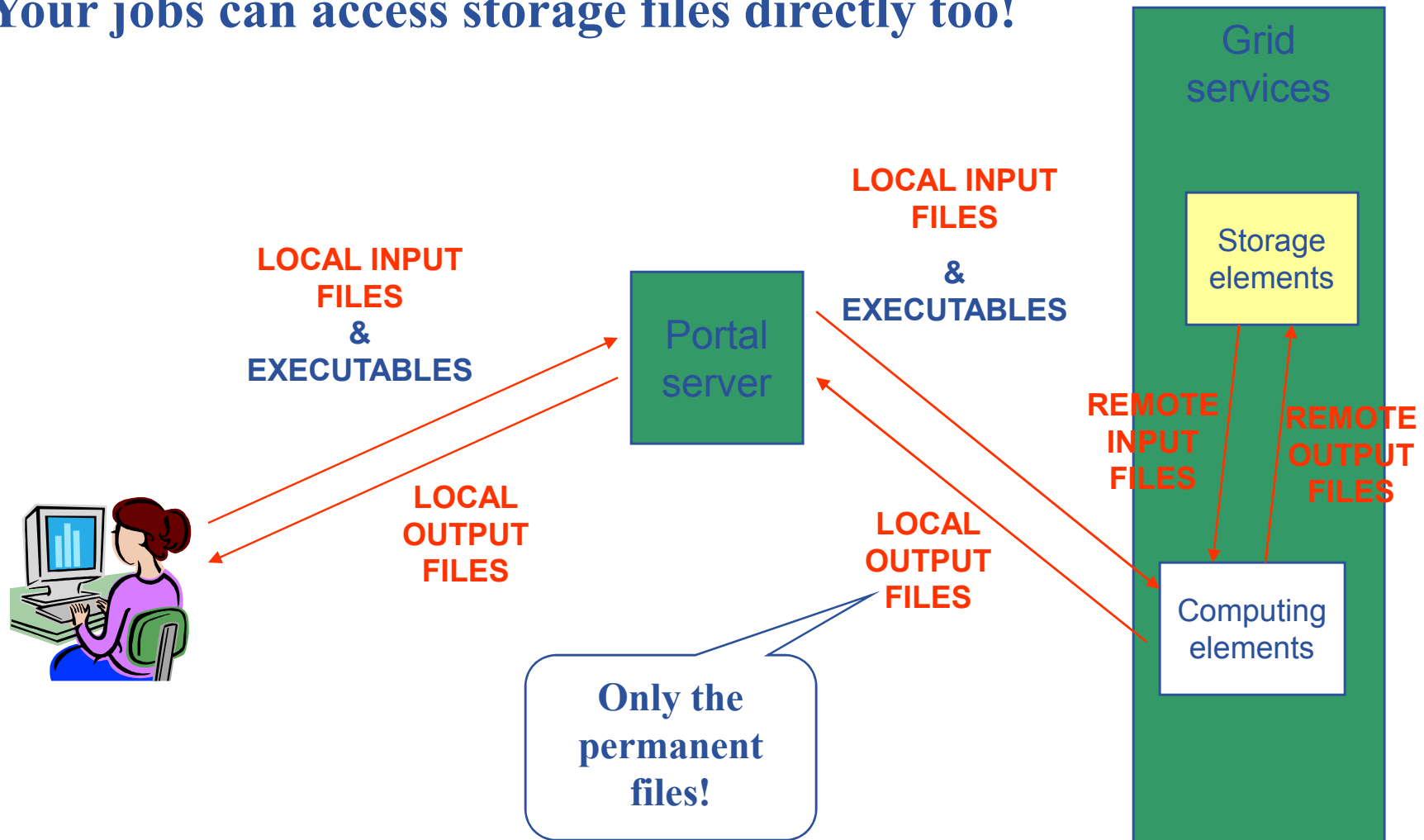

Job level file transfer in EGEE VO

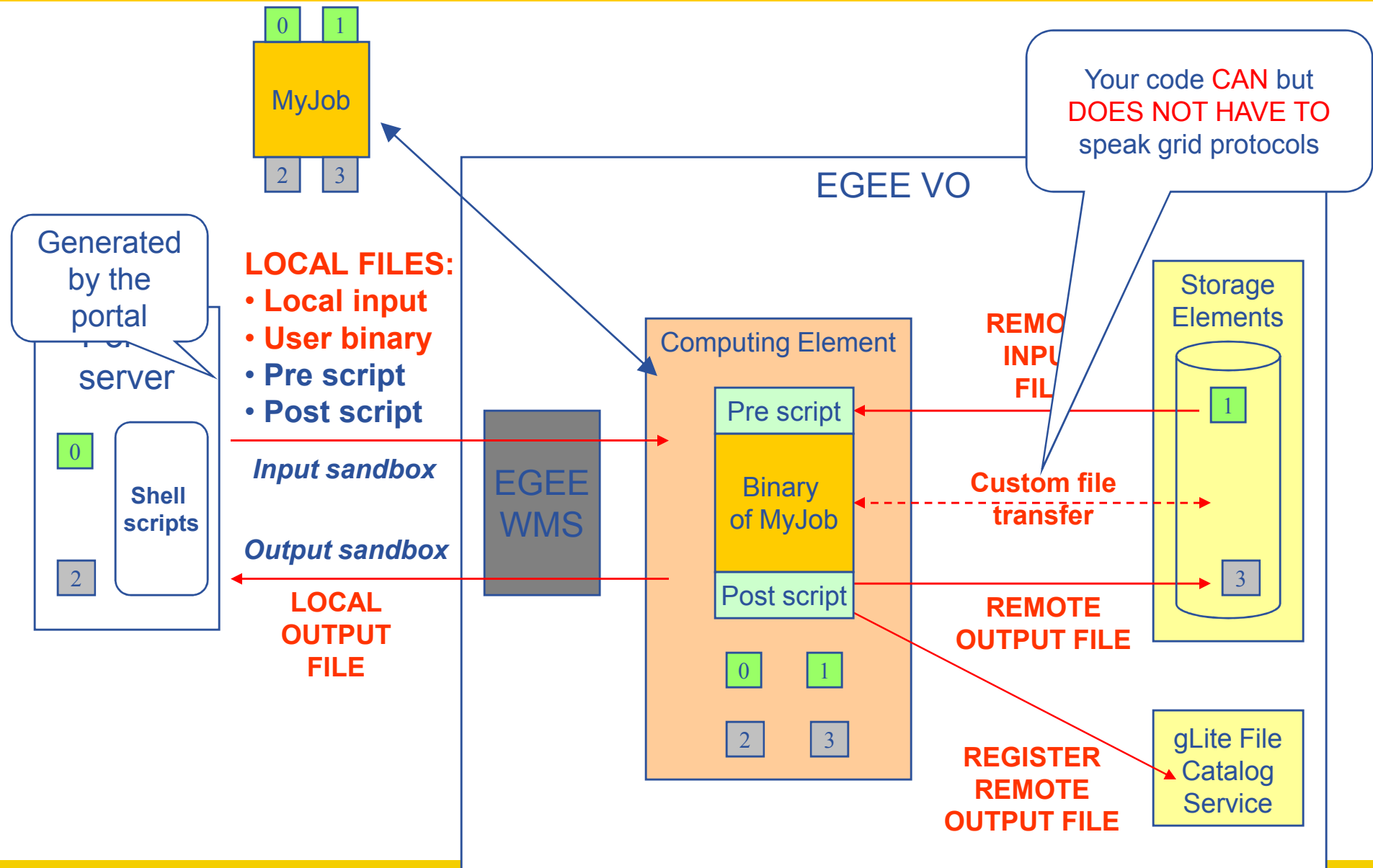

Reminder: Grid files and JDL

Example JDL file

```
Executable = "gridTest";
```

```
StdError = "stderr.log";
```

```
StdOutput
```

lfn: logical file name

```
InputSandbox = {"/home/gilda/te
```

```
OutputSandbox = {"stderr.log", "stdout.log"};
```

```
InputData = "lfn:/grid/gilda/mydir/testbed0-00019";
```

```
OutputData = "lfn:/grid/gilda/mydir/result0-00019";
```

The file itself is NOT transferred by the gLite (or Globus) middleware!

Your binary must transfer input/output grid files!

P-GRADE Portal transfers the file for you.

Your executable does not have to know any grid protocol if it is used in P-GRADE Portal

Workflow Editor

Saving the workflow

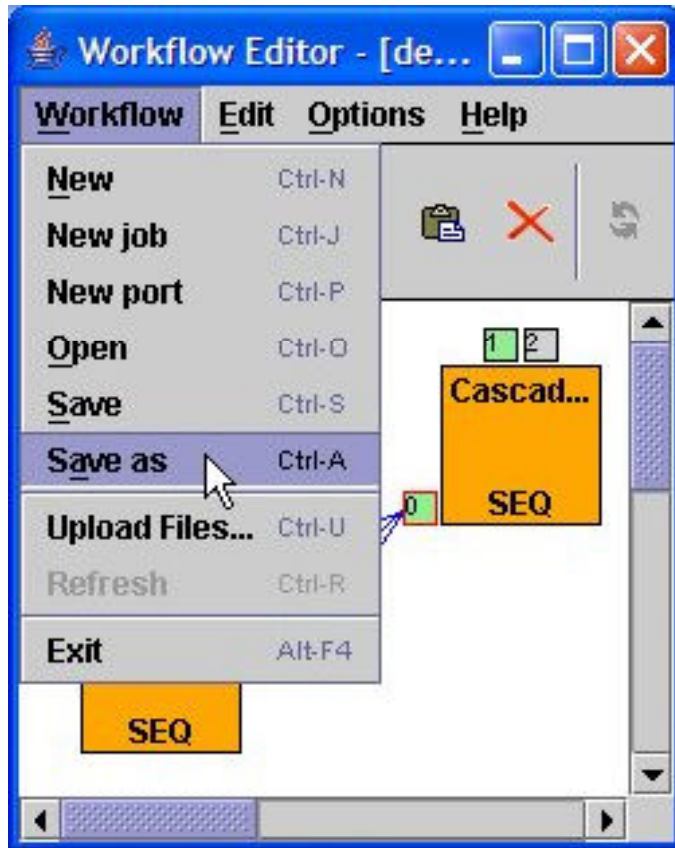

Workflow is defined!

Let's execute it!

Executing workflows with the P-GRADE Portal

Main steps

1. Download proxies
2. Submit workflow
3. Observe workflow progress
4. If some error occurs correct the graph
5. Download result

The typical user scenario

Execution phase – step 1:

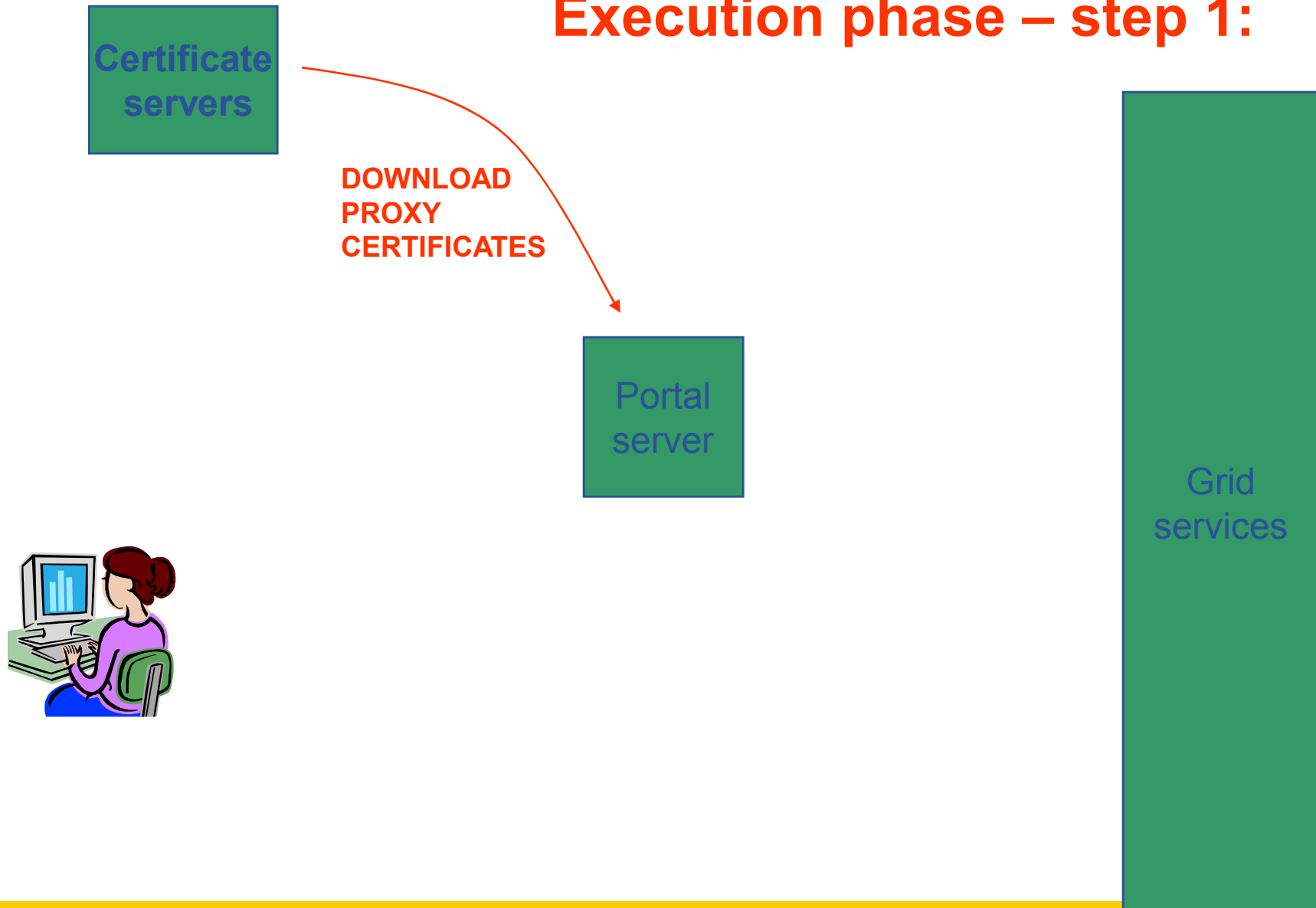

MyProxy interaction in P-GRADE:

Certificate Manager

Certificates portlet

- To start your session on the Grid you must create a proxy certificate on the portal server

- “Certificates” portlet:

- to upload a proxy into MyProxy servers

- to download a proxy from MyProxy into the portal server

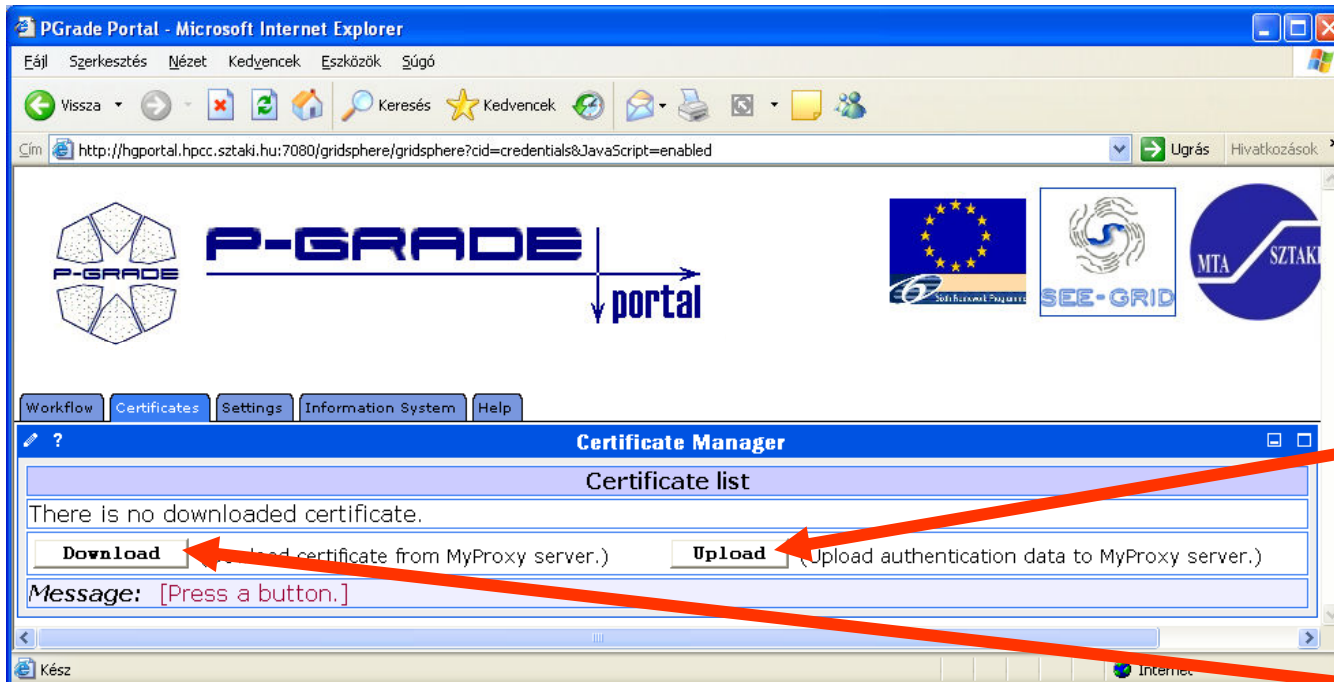

Certificate Manager

Downloading a proxy

1. MyProxy server access details:

- Hostname
- Port number
- User name (from upload)
- Password (from upload)

2. Proxy parameters:

- Lifetime
- Comment

3. Grid association

Workflow Certificates Settings Information System Help

Certificate Manager

Download from MyProxy server

hostname	<input type="text" value="cvs.lpds.sztaki.hu"/>	*	port	<input type="text" value="7512"/>	*
login	<input type="text" value="seecert"/>	*	password	<input type="password" value=""/>	*
lifetime (hours)	<input type="text" value="100"/>	*	description	<input type="text" value=""/>	

*: Cannot be left empty.

Message: Fill in the fields for download!

Internet

Certificates, proxies with gLite VOs:

Download

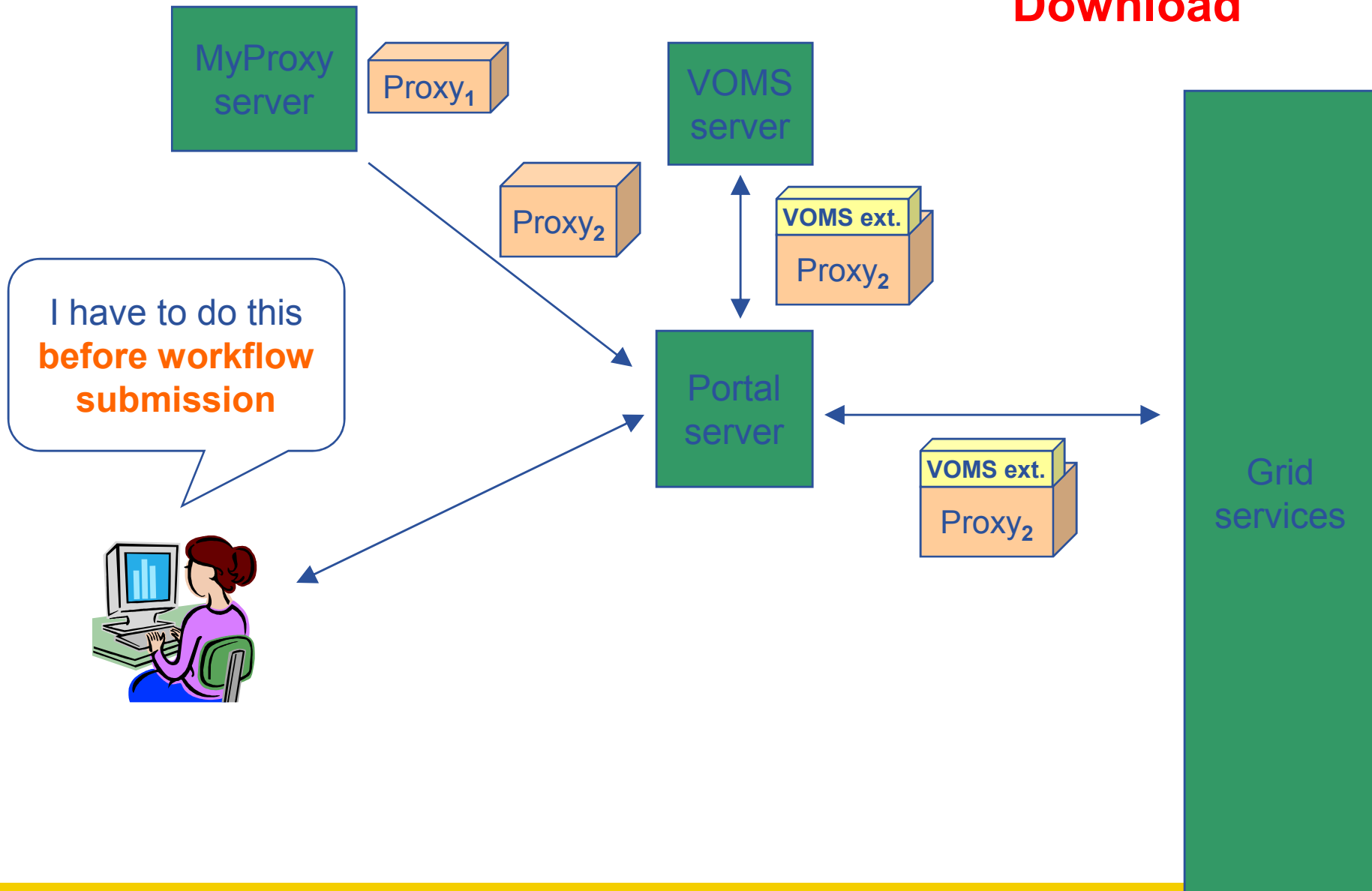

Certificate Manager

Associating the proxy with a grid

The screenshot shows the P-Grade Portal interface in Microsoft Internet Explorer. The browser address bar displays the URL: `http://hgportal.hpcc.sztaki.hu:7080/gridsphere/gridsphere?action=doGoMapProxy&cid=5`. The page features the P-Grade logo and navigation tabs for Workflow, Certificates, Settings, Information System, and Help. The main content area is titled "Certificate Manager" and "Setting certificate for GRID".

Certificate details

Downloaded from:	cvs.lpds.sztaki.hu
Issued by:	DC=ORG,DC=SEE-GRID,O=People,O=SZTAKI,CN=Jozsef Patvarczki,CN=proxy
Subject:	DC=ORG,DC=SEE-GRID,O=People,O=SZTAKI,CN=Jozsef Patvarczki,CN=proxy,CN=proxy
Timeleft:	99:56:46
Proxy type:	full legacy globus proxy
Strength [bits]:	512
Description:	

Select GRID

Select from the list:

- HUNGRID
- HUNGRID
- SEE-GRID
- SZTAKI-GRID

Buttons: OK, Cancel

Message: Map proxy for any of the grids.

This operation displays the **details of the certificate** and the **list of available Grids** (defined by portal administrator)

Certificate Manager

browsing proxies

Multiple proxies can be available on the portal server at the same time!

Workflow Certificates Settings Information System Help

Certificate Manager

Issuer	Set for Grids	Time left	[Actions]
DC=ORG,DC=SEE-GRID,O=People,O=SZTAKI,CN=Jozsef Patvarczki,CN=proxy	SEE-GRID	99:50:24	Details Set for Grid Delete
C=HU,O=KFKI RMKI CA,OU=SZTAKI,CN=Patvarczki Jozsef,CN=proxy	HUNGGRID	99:57:25	Details Set for Grid Delete

Refresh

Download (Download certificate from MyProxy server.) Upload (Upload authentication data to MyProxy server.)

Message: Certificate successfully set for HUNGGRID.

SEE-GRID CEs and SEs

HUNGGRID CEs and SEs

The typical user scenario

Execution phase - step 2:

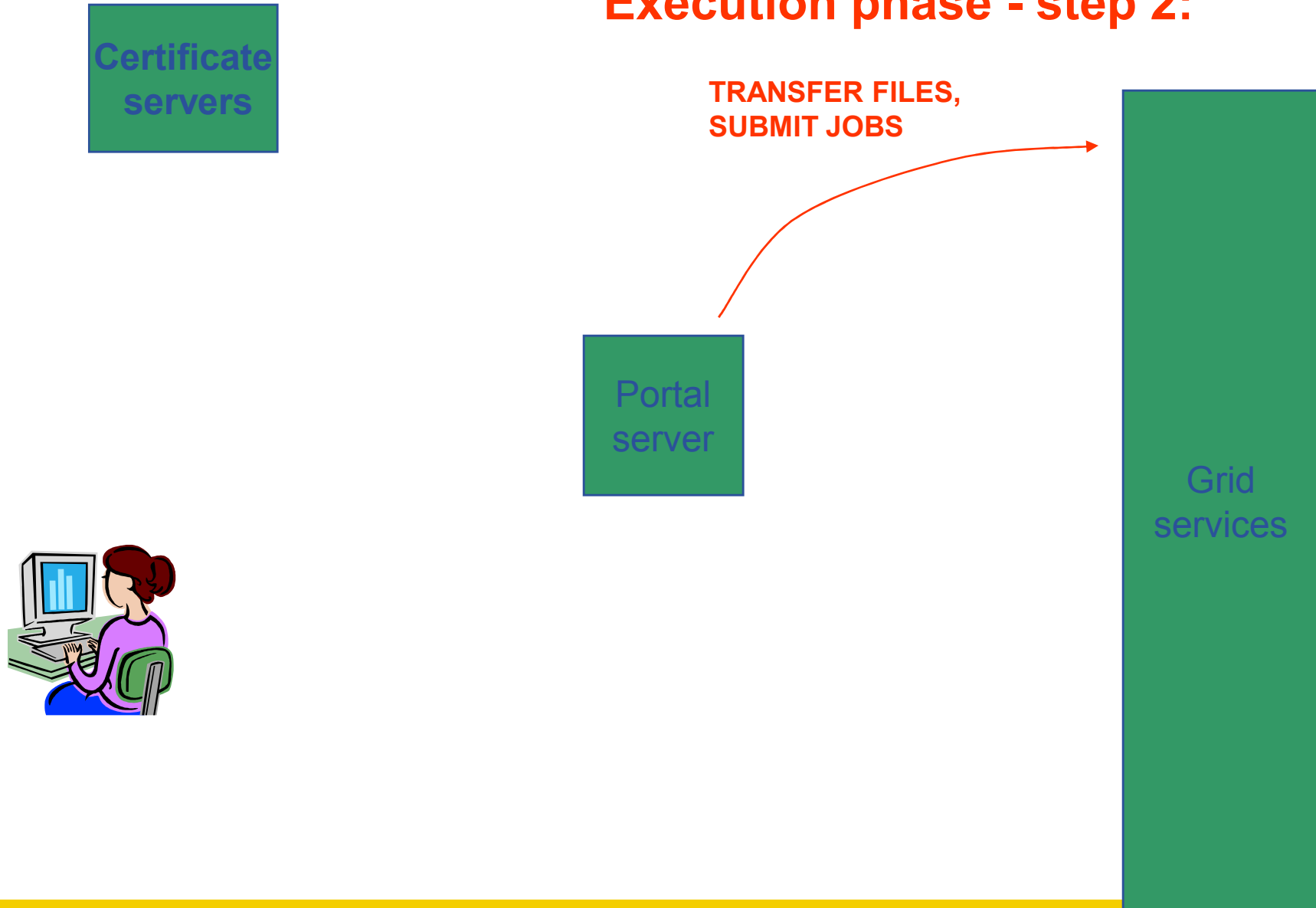

Workflow Management

(workflow portlet)

- The portlet presents the status, size and output of the available workflow in the “**Workflow**” list
- It has a Quota manager to control the users’ storage space on the server
- The portlet also contains the “**Abort**”, “**Attach**”, “**Details**”, “**Delete**” and “**Delete all**” buttons to handle execution of workflows
- The “**Attach**” button opens the workflow in the Workflow Editor
- The “**Details**” button gives an overview about the jobs of the workflow

Workflow Manager

Workflow Editor Refresh

Workflow	Status	Size	Quota (100 Mb)	[Output]	[View]	[Action]
LM_9_DEMO_TOTAL	submitted	26,848 MB	26%	N/A	Details	Abort Attach Delete
		26,848 MB	26%			

Delete all

Message: Workflow successfully submitted.

Workflow Execution

(observation by the workflow portlet)

The screenshot shows a web browser window titled "PGrade Portal - Microsoft Internet Explorer". The address bar shows the URL: <http://hgportal.hpcc.sztaki.hu:7080/gridsphere/gridsphere?action=doShowWorkflowDetails&cid=2>. The page features a navigation menu with "Workflow", "Certificates", "Settings", "Information System", and "Help". Below the menu is a "Workflow Manager" section with "Refresh" and "Back" buttons. A "Job list" table displays the following data:

Workflow	Job	Gridname	Hostname	Status	[Logs]	[Output]	[Visualization]
LM_9_DEMO_TOTAL				submitted	-	N/A	<input type="button" value="Visualize"/> <input type="button" value="All"/> <input type="button" value="Abor"/>
	INIT	SEE-GRID	ce01.grid.acad.bg	init	-	-	-
	LM_P	SEE-GRID	n40.hpcc.sztaki.hu	init	-	-	-
	LM_P.2	SEE-GRID	n40.hpcc.sztaki.hu	init	-	-	-
	LM_S	SEE-GRID	grid-ce.ii.edu.mk	init	-	-	-
	LM_S.2	SEE-GRID	grid1.irb.hr	init	-	-	-
	LM_S.3	SEE-GRID	grid1.netmode.ece.ntua.gr	init	-	-	-
	LM_S.4	SEE-GRID	grid1.irb.hr	init	-	-	-
	LM_S.5	SEE-GRID	testbed001.grid.ici.ro	init	-	-	-
	LM_S.6	HUNGRID	grid109.kfki.hu	init	-	-	-
	TIFF	HUNGRID	grid109.kfki.hu	init	-	-	-

A message at the bottom of the table reads: "Message: Workflow details successfully displayed." The browser's status bar at the bottom shows "Kész" and "Internet".

White/Red/Green color means the job is initial/running/finished state

Workflow Execution

(observation by the workflow portlet)

The screenshot shows a web browser window titled "PGrade Portal - Microsoft Internet Explorer". The address bar shows the URL: <http://hgportal.hpcc.sztaki.hu:7080/gridsphere/gridsphere?action=doGotoPage&cid=2>. The page features a navigation menu with "Workflow", "Certificates", "Settings", "Information System", and "Help". The main content area is titled "Workflow Manager" and contains a "Job list" table. The table has columns for Workflow, Job, Gridname, Hostname, Status, Logs, Output, and Visualization. The "Status" column uses color coding: white for "init", red for "running", and green for "finished". A message at the bottom of the table area reads "Message: Job list refreshed.".

Workflow	Job	Gridname	Hostname	Status	[Logs]	[Output]	[Visualization]
LM_9_DEMO_TOTAL				running	-	N/A	<input type="button" value="Visualize"/> <input type="button" value="All"/> <input type="button" value="Abort"/>
	INIT	SEE-GRID	ce01.grid.acad.bg	running	-	-	-
	LM_P	SEE-GRID	n40.hpcc.sztaki.hu	init	-	-	-
	LM_P.2	SEE-GRID	n40.hpcc.sztaki.hu	init	-	-	-
	LM_S	SEE-GRID	grid-ce.ii.edu.mk	init	-	-	-
	LM_S.2	SEE-GRID	grid1.irb.hr	init	-	-	-
	LM_S.3	SEE-GRID	grid1.netmode.ece.ntua.gr	init	-	-	-
	LM_S.4	SEE-GRID	grid1.irb.hr	init	-	-	-
	LM_S.5	SEE-GRID	testbed001.grid.ici.ro	init	-	-	-
	LM_S.6	HUNGRID	grid109.kfki.hu	init	-	-	-
	TIFF	HUNGRID	grid109.kfki.hu	init	-	-	-

White/Red/Green color means the job is initial/running/finished state

Workflow Execution

(observation by the workflow portlet)

The screenshot shows a web browser window titled "PGrade Portal - Microsoft Internet Explorer". The address bar contains the URL: <http://hgportal.hpcc.sztaki.hu:7080/gridsphere/gridsphere?action=doGotoPage&cid=2>. The page content includes a navigation menu with "Workflow", "Certificates", "Settings", "Information System", and "Help". Below this is the "Workflow Manager" section, which contains "Refresh" and "Back" buttons. The main area is a "Job list" table with the following data:

Workflow	Job	Gridname	Hostname	Status	[Logs]	[Output]	[Visualization]
LM_9_DEMO_TOTAL				running	-	N/A	<input type="button" value="Visualize"/> <input type="button" value="All"/> <input type="button" value="Abort"/>
	INIT	SEE-GRID	ce01.grid.acad.bg	finished	- -		-
	LM_P	SEE-GRID	n40.hpcc.sztaki.hu	init	- -		-
	LM_P.2	SEE-GRID	n40.hpcc.sztaki.hu	init	- -		-
	LM_S	SEE-GRID	grid-ce.ii.edu.mk	running	- -		-
	LM_S.2	SEE-GRID	grid1.irb.hr	finished	<input type="button" value="Out"/>	-	-
	LM_S.3	SEE-GRID	grid1.netmode.ece.ntua.gr	running	<input type="button" value="Out"/>	-	-
	LM_S.4	SEE-GRID	grid1.irb.hr	finished	<input type="button" value="Out"/>	-	-
	LM_S.5	SEE-GRID	testbed001.grid.ici.ro	running	<input type="button" value="Out"/>	-	-
	LM_S.6	HUNGRID	chemgrid3.chemres.hu	finished	<input type="button" value="Out"/>	-	-
	TIFF	HUNGRID	grid109.kfki.hu	init	- -		-

Message: Job list refreshed.

White/Red/Green color means the job is initial/running/finished state

Workflow Execution

(observation by the workflow portlet)

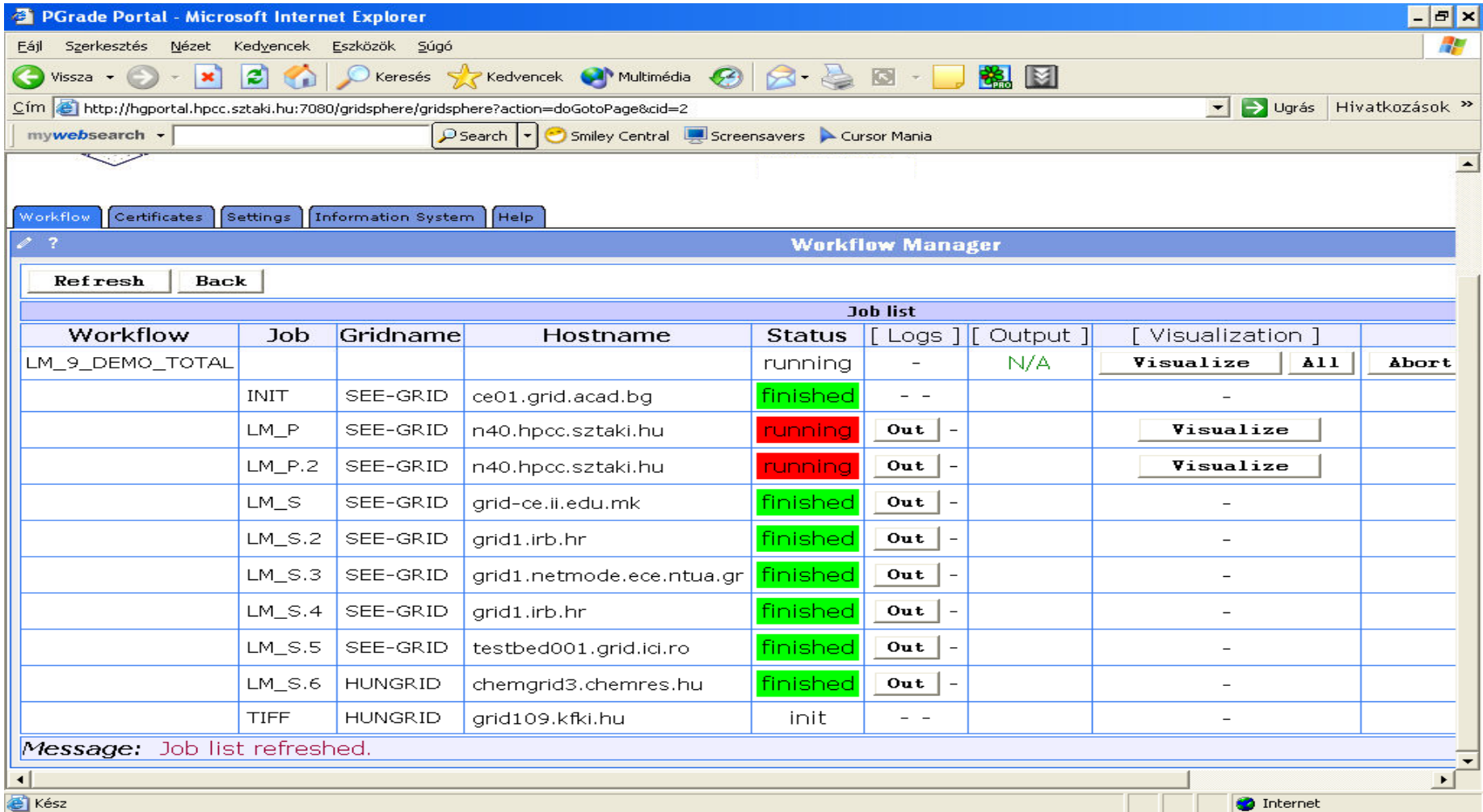

Workflow Manager

Refresh Back

Workflow	Job	Gridname	Hostname	Status	[Logs]	[Output]	[Visualization]
LM_9_DEMO_TOTAL				running	-	N/A	Visualize All Abort
	INIT	SEE-GRID	ce01.grid.acad.bg	finished	- -		-
	LM_P	SEE-GRID	n40.hpcc.sztaki.hu	running	Out	-	Visualize
	LM_P.2	SEE-GRID	n40.hpcc.sztaki.hu	running	Out	-	Visualize
	LM_S	SEE-GRID	grid-ce.ii.edu.mk	finished	Out	-	-
	LM_S.2	SEE-GRID	grid1.irb.hr	finished	Out	-	-
	LM_S.3	SEE-GRID	grid1.netmode.ece.ntua.gr	finished	Out	-	-
	LM_S.4	SEE-GRID	grid1.irb.hr	finished	Out	-	-
	LM_S.5	SEE-GRID	testbed001.grid.ici.ro	finished	Out	-	-
	LM_S.6	HUNGRID	chemgrid3.chemres.hu	finished	Out	-	-
	TIFF	HUNGRID	grid109.kfki.hu	init	- -		-

Message: Job list refreshed.

White/Red/Green color means the job is initial/running/finished state

Workflow Execution

(observation by the workflow portlet)

PGrade Portal - Microsoft Internet Explorer

http://hgportal.hpcc.sztaki.hu:7080/gridsphere/gridsphere?action=doGotoPage&cid=2

Workflow Certificates Settings Information System Help

Workflow Manager

Refresh Back

Job list									
Workflow	Job	Gridname	Hostname	Status	[Logs]	[Output]	[Visualization]		
LM_9_DEMO_TOTAL				finished	Err	Being zipped..	Visualize	All	S
	INIT	SEE-GRID	ce01.grid.acad.bg	finished	-	-	-	-	-
	LM_P	SEE-GRID	n40.hpcc.sztaki.hu	finished	Out	-	Visualize	-	-
	LM_P.2	SEE-GRID	n40.hpcc.sztaki.hu	finished	Out	-	Visualize	-	-
	LM_S	SEE-GRID	grid-ce.il.edu.mk	finished	Out	-	-	-	-
	LM_S.2	SEE-GRID	grid1.irb.hr	finished	Out	-	-	-	-
	LM_S.3	SEE-GRID	grid1.netmode.ece.ntua.gr	finished	Out	-	-	-	-
	LM_S.4	SEE-GRID	grid1.irb.hr	finished	Out	-	-	-	-
	LM_S.5	SEE-GRID	testbed001.grid.idi.ro	finished	Out	-	-	-	-
	LM_S.6	HUNGRID	chemgrid3.chemres.hu	finished	Out	-	-	-	-
	TIFF	HUNGRID	grid109.kfki.hu	finished	Out	-	-	-	-

Message: Job list refreshed.

White/Red/Green color means the job is initialised/running/finished

The typical user scenario

Execution phase – step 3:

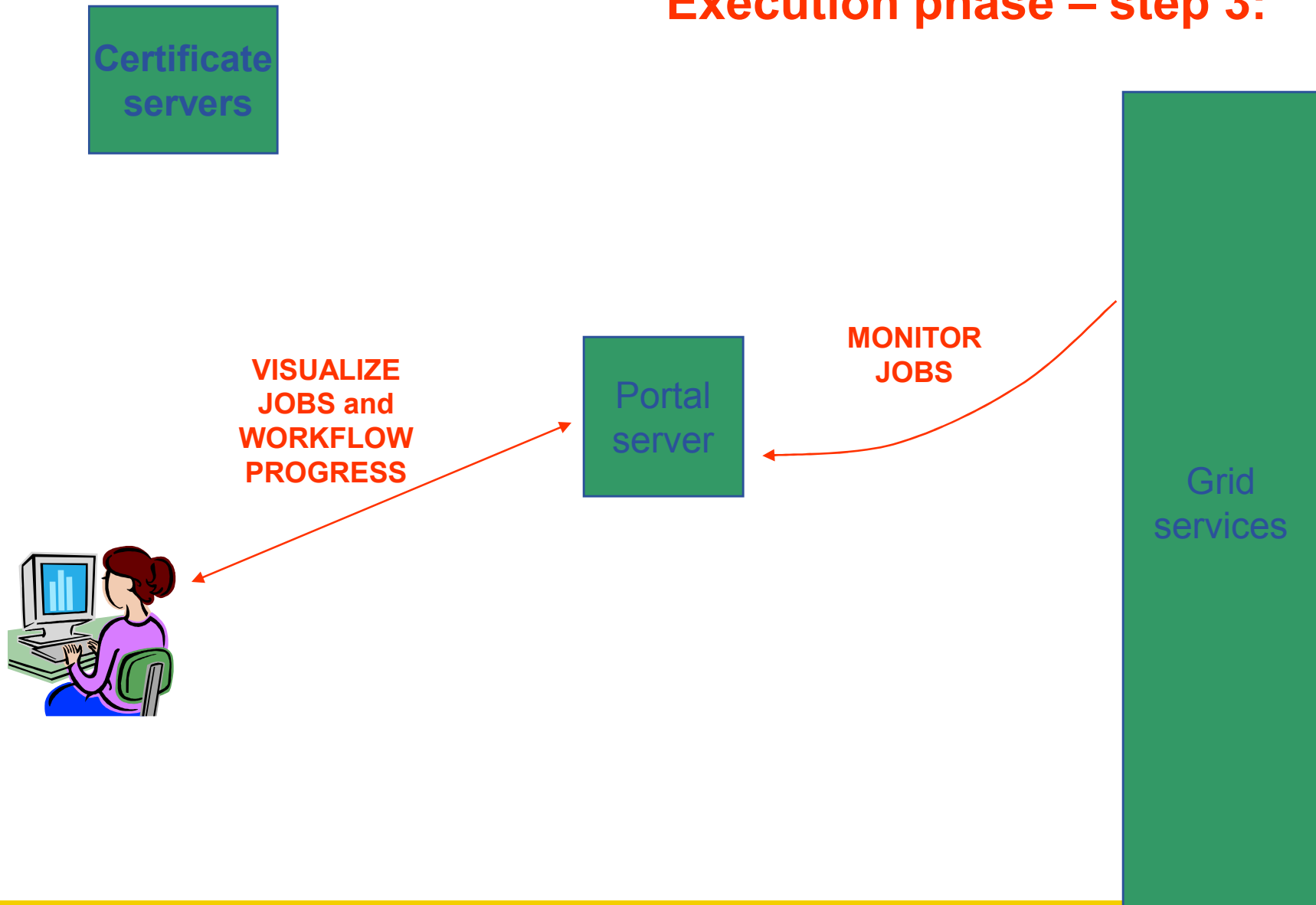

On-Line Monitoring both at the workflow and job levels (workflow portlet)

- The portal monitors and visualizes workflow progress

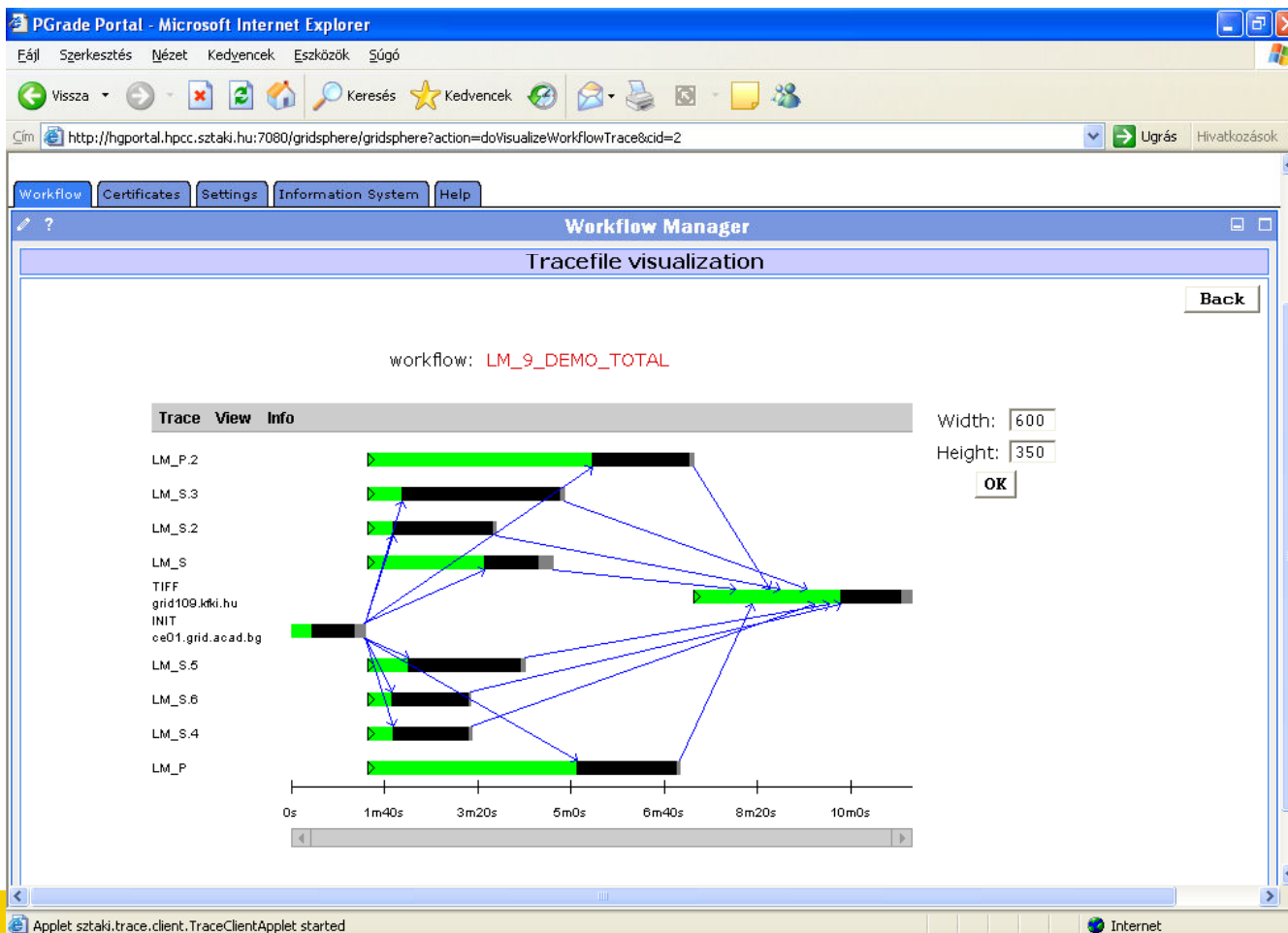

Rescuing a failed workflow 1.

The screenshot shows the GridSphere Portal interface in Microsoft Internet Explorer. The main content area is titled "Workflow Manager" and displays a "Job list" table. The table has columns for Workflow, Job, Gridname, Host, Status, Logs, Output, Visualization, and Action. A job named "demo-RESCUE" is highlighted, and its status is "rescue", which is circled in red. Below the table, a message states "Message: Workflow details successfully displayed." and the date "July 29, 2005" is shown at the bottom.

Workflow	Job	Gridname	Host	Status	[Logs]	[Output]	[Visualization]	[Action]
demo-RESCUE				rescue	Err	N/A		Rescue Abort Attach Delete
	Count1	SZTAKI-GRID	n0 .hpcc.sztaki.hu	finished	Out	-	-	
	Count2	SZTAKI-GRID	n0 .hpcc.sztaki.hu	finished	Out	-	-	
	Count3	HUNGRID	chemgrid3 .chemres.hu	error	Err	-	-	
	Count4	SZTAKI-GRID	n0 .hpcc.sztaki.hu	submitted	--	-	-	

Message: Workflow details successfully displayed.

July 29, 2005

A job failed during workflow execution

Read the error log to know why

Rescuing a failed workflow 2.

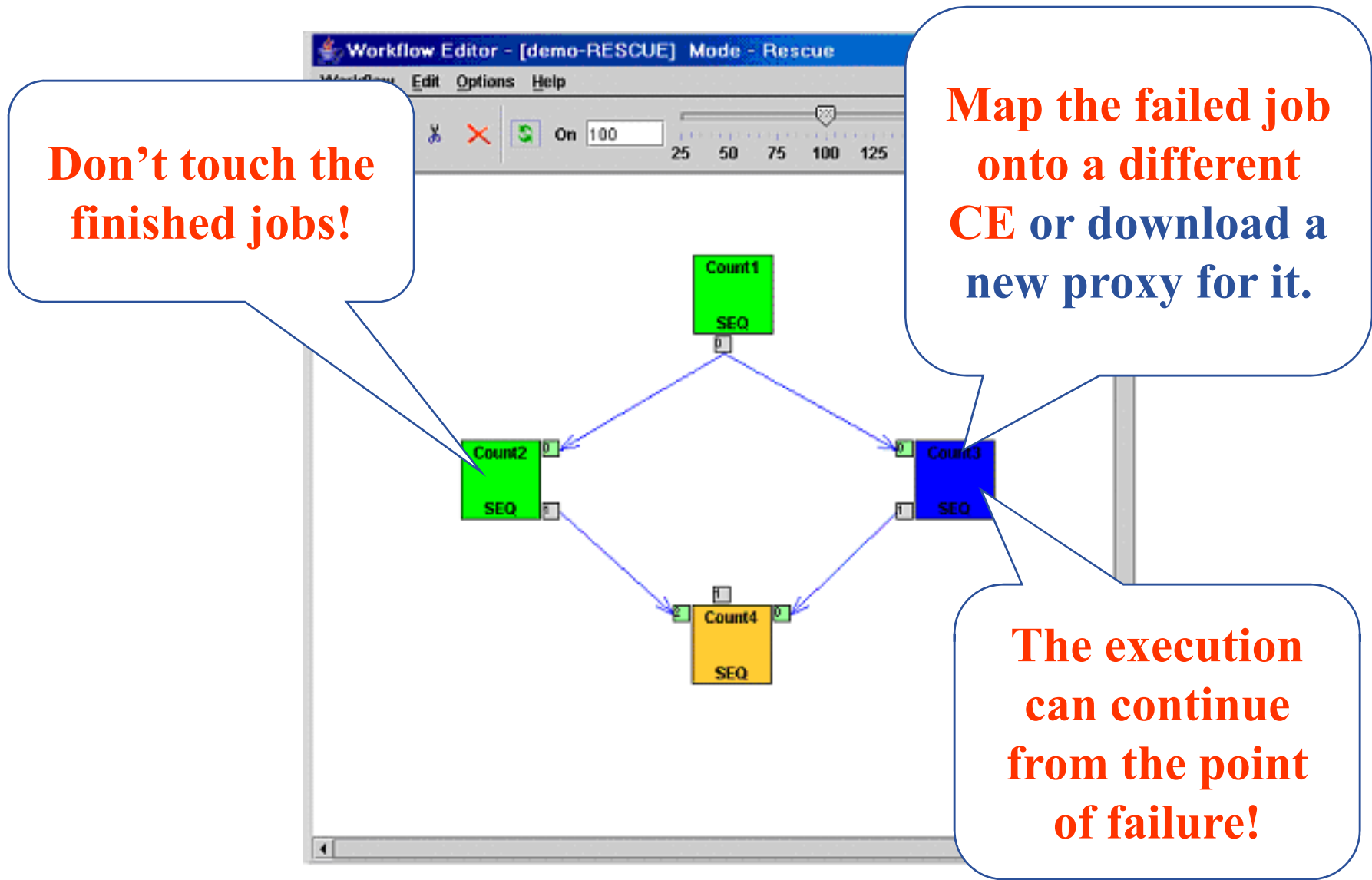

Don't touch the finished jobs!

Map the failed job onto a different CE or download a new proxy for it.

The execution can continue from the point of failure!

Rescuing a failed workflow 3.

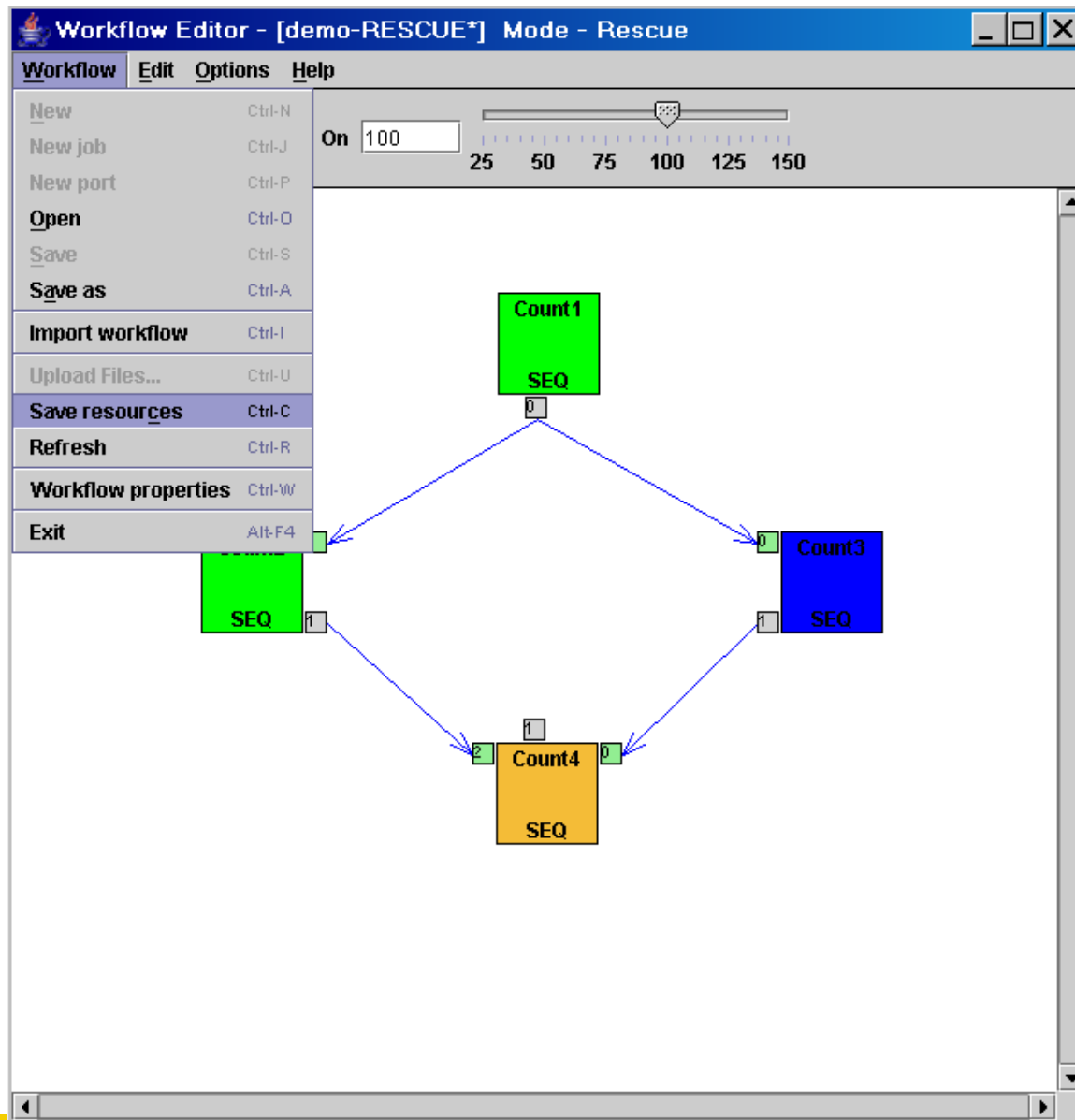

Rescuing a failed workflow 4.

The screenshot shows the GridSphere Portal interface in Microsoft Internet Explorer. The browser address bar displays the URL: `http://hgportal.hpcc.sztaki.hu:9080/gridsphere/gridsphere?cid=63&gs_mode=view&gs_state=normal&gs_action=doShowWorkflowD`. The page header includes the P-GRADE logo and the text "RELEASE 2.2". Below the header is a navigation menu with tabs: "Welcome", "Workflow", "Certificates", "Settings", "Information System", and "Help". The main content area is titled "Workflow Manager" and contains a "Job list" table. The table has columns for "Workflow", "Job", "Gridname", "Hostname", "Status", "[Logs]", "[Output]", "[Visualization]", and "[Action]". The first row of the table is highlighted and has a red circle around the "Rescue" button in the "Action" column. Below the table, a message box displays: "Message: Workflow details successfully displayed." The date "July 29, 2005" is shown at the bottom of the page.

Workflow	Job	Gridname	Hostname	Status	[Logs]	[Output]	[Visualization]	[Action]
demo-RESCUE				rescue	Err	N/A	Visualize All	Rescue Abort Attach Delete
	Count1	SZTAKI-GRID	n0 .hpcc.sztaki.hu	finished	Out	-	-	
	Count2	SZTAKI-GRID	n0 .hpcc.sztaki.hu	finished	Out	-	-	
	Count3	HUNGRID	chemgrid3 .chemres.hu	error	- Err	-	-	
	Count4	SZTAKI-GRID	n0 .hpcc.sztaki.hu	submitted	--	-	-	

Message: Workflow details successfully displayed.

July 29, 2005

Resume workflow
by the Rescue
button

Logs provided for each job

PGrade Grid portal - Microsoft Internet Explorer

Address: https://n42.hpcc.sztaki.hu:8443/gridsphere/gridsphere?cid=77&gs_action=doShowWorkflowDetails

RELEASE 2.6

P-GRADE portal

MTA SZTAKI

Logout
Welcome, Peter Kacsuk

Welcome Workflow Certificates Settings Information System File Management Help

Workflow Manager: Storage Upload

Workflow Manager

Refresh Back

Job list

Workflow	Job	Gridname	Hostname	Status	[Logs]	[Output]	[Visualization]	[Action]
Ax_EQUAL_B_gLite_broker_multi_VO				finished	-	✓	Visualize All	Submit Attach
	A_mul_X	hungrid_LCG_2_BROKER	eszakigrid66.inf.elte.hu	finished	Out - Log	✓		-
	Copy_A	seegrid_GLITE_BROKER	ce02.grid.acad.bg	finished	Out - Log	✓		-
	Copy_B	hungrid_LCG_2_BROKER	eszakigrid66.inf.elte.hu	finished	Out - Log	✓		-
	Invert_A	gilda_LCG_2_BROKER	ce-nano-37.to.infn.it	finished	Out - Log	✓		-
	Multip_B	seegrid_GLITE_BROKER	ce001.grid.uni-sofia.bg	finished	Out - Log	✓		-
	Subtr-B	gilda_LCG_2_BROKER	ce-nano-37.to.infn.it	finished	Out - Log	✓		-

Miklo Done Internet 51

- 2008.01.09 09:32:19 - Proxy with VOMS extensions created for VO "voce" with accounting group "".
- 2008.01.09 09:32:19 - Job submission in progress...
- 2008.01.09 09:32:23 - Job has been submitted successfully!
- 2008.01.09 09:32:23 - Job identifier is:
- "https://skurut1.cesnet.cz:9000/mD_8VzPhm8AmIToTJKtigg"
- 2008.01.09 09:32:26 - EGEE job's status has changed to **"Waiting"** (host is).
- 2008.01.09 09:33:00 - EGEE job's status has changed to **"Ready"** (host is **ce1-egee.srce.hr**).
- 2008.01.09 09:35:46 - EGEE job's status has changed to **"Waiting"** (host is **egee-ce.grid.niif.hu**).
- 2008.01.09 09:36:19 - EGEE job's status has changed to **"Ready"** (host is **ce.cyf-kr.edu.pl**).
- 2008.01.09 09:36:53 - EGEE job's status has changed to **"Waiting"** (host is **ce.cyf-kr.edu.pl**).
- 2008.01.09 09:37:26 - EGEE job's status has changed to **"Done"** (host is **egee-ce.grid.niif.hu**).
- 2008.01.09 09:37:26 - Job found to be finished. **Checking again if this is really the case.**
- 2008.01.09 09:38:03 - EGEE job's status has changed to **"Ready"** (host is **egee-ce1.gup.uni-linz.ac.at**).

Fault-tolerance by P-GRADE portal

- 09:33: the broker assigned the job to a site: `ce1-egEE.srce.hr`
- 09:35: The broker moved the job to another site: `egEE-ce.grid.niif.hu`
- 09:36: Again the broker moved the job to another site: `ce.cyf-kr.edu.pl`
- 09:37: The broker indicated that the job is **Done**, but .
- 09:38: ... It turned out that the job was not finished (**Done - Failed** status), only it was moved to another site: `egEE-ce1.gup.uni-linz.ac.at`
- 09:39: Again the broker moved the job to another site: `ares02.cyf-kr.edu.pl`
- 09:39: Again the broker moved the job to another site: `ce.cyf-kr.edu.pl`
- 09:40: **After trying 10 different sites the VOCE broker gave it up and aborted the job** (the Shallow RetryCount was set for 10):

- 2008.01.09 09:40:16 - **The job has been aborted!**

Fault-tolerance by P-GRADE portal

- **Our fault-tolerant portal did not give it up:**
- 2008.01.09 09:40:16 - The job can be submitted again (try 1 out of 3, **excluding host(s): ce.cyf-kr.edu.pl**)
- 2008.01.09 09:40:17 - Proxy with VOMS extensions created for VO "voce" with accounting group "".
- 2008.01.09 09:40:17 - Job submission in progress...
- 2008.01.09 09:40:27 - Job has been submitted successfully!
- 2008.01.09 09:40:27 - Job identifier is:
"https://skurut1.cesnet.cz:9000/o22BTVqQsvwzj2wn5KP8_A"
- 2008.01.09 09:40:30 - EGEE job's status has changed to **"Waiting"** (host is).
- 2008.01.09 09:41:04 - EGEE job's status has changed to "Ready" (host is **eszakigrid66.inf.elte.hu**).

Fault-tolerance by P-GRADE portal

- 2008.01.09 09:41:37 - EGEE job's status has changed to "**Scheduled**" (host is eszakigrid66.inf.elte.hu).
- 2008.01.09 09:44:57 - EGEE job's status has changed to "**Done**" (host is eszakigrid66.inf.elte.hu).
- 2008.01.09 09:44:57 - Job found to be finished. Checking again if this is really the case.
- 2008.01.09 09:45:34 - EGEE job's status has changed to "Waiting" (host is eszakigrid66.inf.elte.hu).
- 2008.01.09 10:06:06 - **The job's status hasn't changed for 20 minutes, resubmitting...**

It is a quite frequently occurring problem in EGEE-like grids that the broker leaves jobs stuck in CEs. queues.) In such case the portal automatically kills the job on this site and resubmits it to the broker.

- 2008.01.09 10:06:06 - Proxy with VOMS extensions created for VO "voce" with accounting group "".
- 2008.01.09 10:06:06 - Job submission in progress...
- 2008.01.09 10:06:12 - Job has been submitted successfully!
- 10:10: **The job successfully finished** with exit code 0 on site: ce.ui.savba.sk

The typical user scenario

Execution phase – step 5

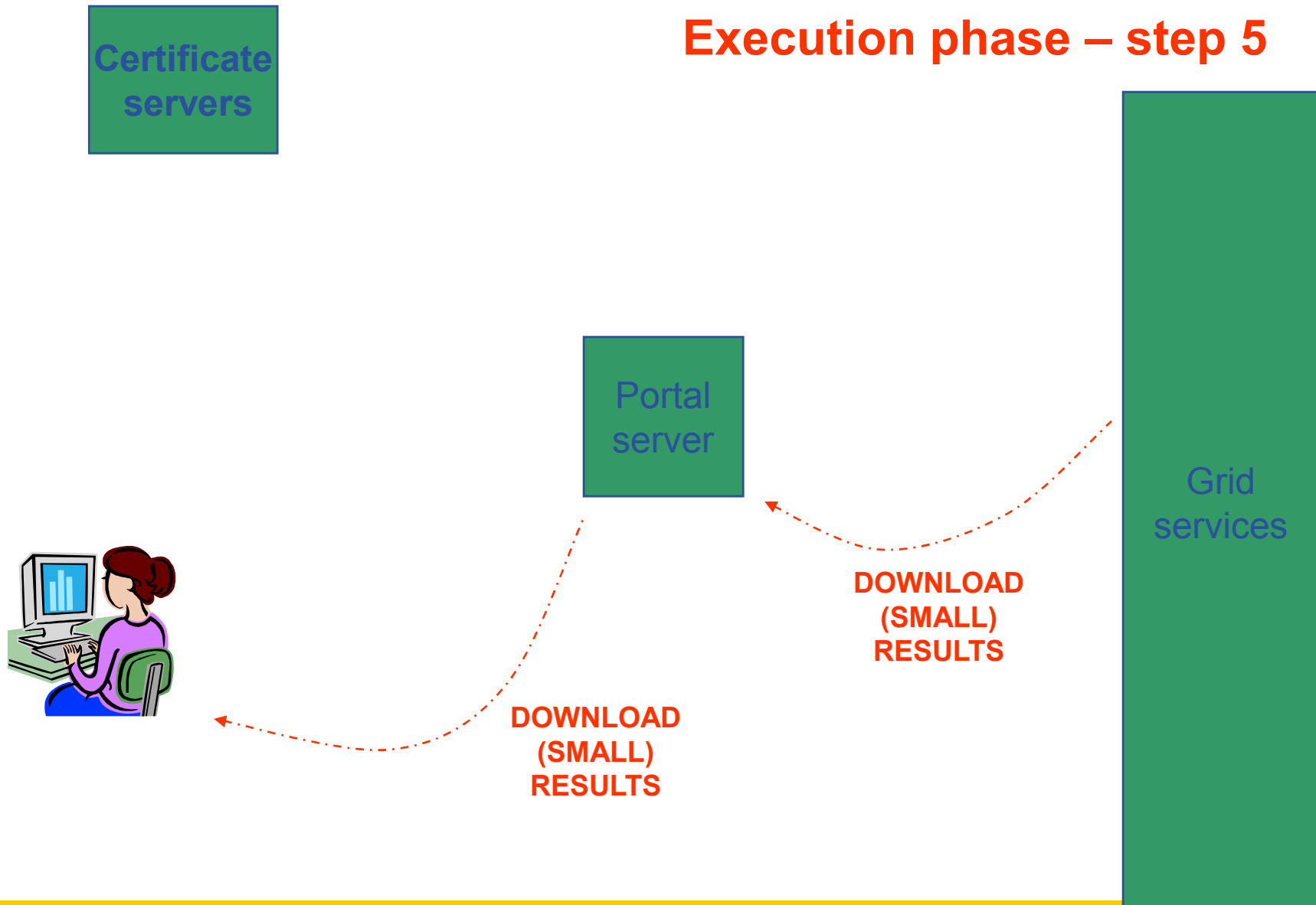

Downloading the results...

The screenshot shows a Mozilla browser window displaying the P-Grade Portal. The page includes a navigation menu with 'Workflow', 'Credentials', 'Settings', 'Demo', and 'Help'. A 'Workflow Manager' section contains a 'Job list' table with columns for Workflow, Job, Hostname, Status, Logs, Output, Visualization, and Action. A message at the bottom states 'Message: Job list refreshed.' An 'Opening nowcast_final_g.zip' dialog box is overlaid on the page, asking the user what to do with the file.

Workflow	Job	Hostname	Status	[Logs]	[Output]	[Visualization]	[Action]
nowcast-final-g_SGE			finished		✓	Visualize All	Subm Attach Delete
	cummu	n0.hpcc.sztaki.hu	finished	--		Visualize	
	delta	n0.hpcc.sztaki.hu	finished	--		Visualize	
	ready	n0.hpcc.sztaki.hu	finished	--		Visualize	
	satel	n0.hpcc.sztaki.hu	finished	--			
	visib	n0.hpcc.sztaki.hu	finished	--			

Opening nowcast_final_g.zip

The file "nowcast_final_g.zip" is of type application/x-zip-compressed, and Mozilla does not know how to handle this file type. This file is located at:
e:\pri\mc04

What should Mozilla do with this file?

- Open it with the default application
- Open it with - Save it to disk
- Always perform this action when handling files of this type

OK Cancel

File management portlet

The screenshot shows a web browser window titled "PGrade Grid portal - Microsoft Internet Explorer". The address bar contains the URL "https://n42.hpcc.sztaki.hu:8443/gridsphere/gridsphere?cid=127". The page has a navigation menu with tabs: "Welcome", "Workflow", "Certificates", "Settings", "Information System", "File Management" (selected), and "Help".

The "File Management" portlet is displayed. It includes the following controls:

- Select Grid:
- Select VO:
- Select LFC Host:
- or Enter:

The "File Browser" section shows a list of directories:

- + Balasko
 - POSIX-TEST-10485-24626
 - POSIX-TEST-11134-23067
 - POSIX-TEST-12464-3948
 - POSIX-TEST-16138-5559
 - POSIX-TEST-17957-20543
 - POSIX-TEST-20716-13234
 - POSIX-TEST-24498-25005
 - POSIX-TEST-24776-20792
 - POSIX-TEST-27728-19524
 - POSIX-TEST-29926-26667
 - POSIX-TEST-3182-23422
 - POSIX-TEST-6451-13508
 - POSIX-TEST-7730-27146
- + SAM
 - SE-lcg-cr-cluster1.csk.kg.ac.yu-temp-1177332816

Navigation and action buttons on the right include: "Go Up", "Change Directory", "Remove", "Details", "Replicas", "Make Directory" (with an input field), and "Rename" (with an input field).

At the bottom, the "Current Path" is "/grid/seegrid". There are "Download" and "Upload" buttons. A message at the bottom states: "Message: LFC name server directory/file entries listed".

- Pros.
 - Easy-to-use workflow system with graphical editor
 - Easy-to-use parameter sweep concept at workflow level
 - Multi-grid / multi-VO access mechanism: job submission to LCG, gLite and GT2
 - Intelligent handling of grid errors
 - Open source community on Sourceforge
 - Reliable, production installations for several Grid, EGEE VOs
 - Part of EGEE RESPECT programme
 - ...
 - Features can serve most grid scenarios

To become a user of P-GRADE Portal

- Become user of EGEE
- Select a portal installation: <http://portal.p-grade.hu>

Portal installations

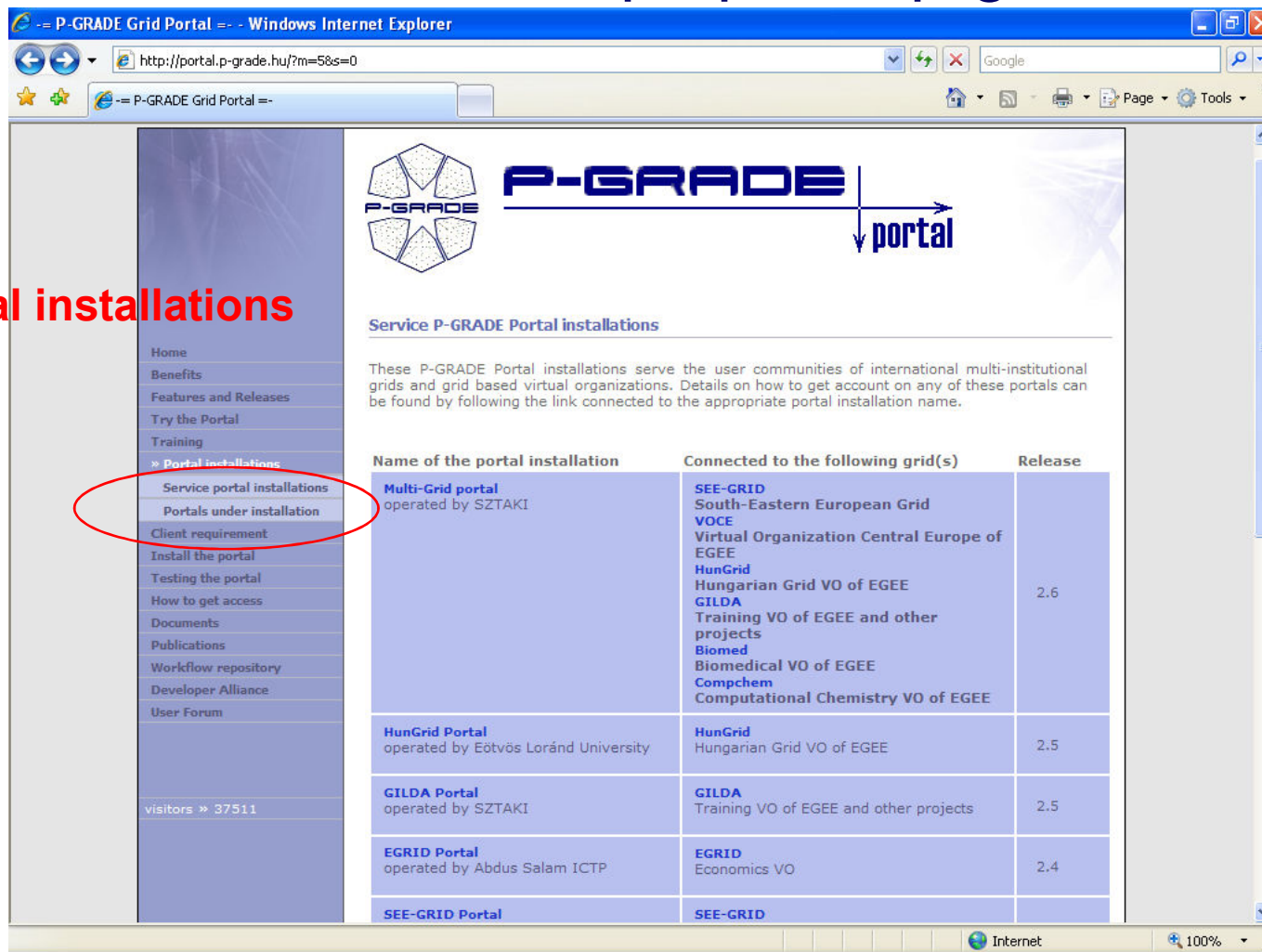

The screenshot shows a Windows Internet Explorer browser window displaying the P-Grade Portal website. The browser's address bar shows the URL <http://portal.p-grade.hu/?m=5&s=0>. The website features a navigation menu on the left with the 'Portal installations' link highlighted in red. The main content area is titled 'Service P-Grade Portal installations' and contains a table listing various portal installations.

Name of the portal installation	Connected to the following grid(s)	Release
Multi-Grid portal operated by SZTAKI	SEE-GRID South-Eastern European Grid VOCE Virtual Organization Central Europe of EGEE HunGrid Hungarian Grid VO of EGEE GILDA Training VO of EGEE and other projects Biomed Biomedical VO of EGEE Compchem Computational Chemistry VO of EGEE	2.6
HunGrid Portal operated by Eötvös Loránd University	HunGrid Hungarian Grid VO of EGEE	2.5
GILDA Portal operated by SZTAKI	GILDA Training VO of EGEE and other projects	2.5
EGRID Portal operated by Abdus Salam ICTP	EGRID Economics VO	2.4
SEE-GRID Portal	SEE-GRID	

To become a user of P-GRADE Portal contd.

RELEASE 2.6

Magyar

P-GRADE portal

MTA SZTAKI

GridSphere

Otthon

Welcome to the P-GRADE multi-VO Portal!

This portal serves the following VOs of EGEE:

- SEE-GRID (South-East European Grid)
- VOCE (VO Central Europe)
- HunGrid (Hungarian VO)
- GILDA (Training infrastructure of EGEE)
- Biomed (Biomedical VO of EGEE)
- Compchem (Computational Chemistry VO of EGEE)

You can use the portal with all these VOs and you can run your workflows simultaneously on any of the sites of these VOs provided that you have valid certificates for the VOs.
If you wish to get a valid certificate for these VOs, please contact the VO support teams. Once you have the required certificate, please, contact the portal administrator and apply for a portal account. If you wish to get an account for this Portal please follow this link: [get access](#)
If you need any assistance please e-mail to the support team: portalreq@lpds.sztaki.hu

This portal works under a GPL license.

This portal is based on **P-GRADE Grid Portal** technology, which was developed by the Laboratory of Parallel and Distributed Systems at MTA-SZTAKI, Hungary. The **P-GRADE Portal** is a workflow-oriented Grid portal that enables the creation, execution and monitoring of computational workflows in Grid environments through high-level, graphical Web interfaces. The **P-GRADE Portal** serves various Grid Communities in research and industry.

This site is built with **P-GRADE Portal** version 2.6 software. This Portal has been tested with Mozilla 1.6, Netscape (4.x, 6 and higher) and Internet Explorer (5 or higher) with JRE 1.4.2_x and 1.5.0_06 Java plug in. Using other versions of Web browsers or Java Virtual Machines may lead to visualization problems.

Bejelentkezés

Felhasználó

Jelszó

Remember my login

[Elfelejtett a jelszavad?](#)

Get access

Done Internet 100%

Thank you

Miklos Kozlovsky

m.kozlovsky@sztaki.hu

www.lpds.sztaki.hu

