Lecture 12 - Radiofrequency Cavities II

Professor Emmanuel Tsesmelis
Principal Physicist, CERN
Department of Physics, University of Oxford

Accelerator Physics Graduate Course
John Adams Institute for Accelerator Science
9 November 2016

Table of Contents II

- Group Velocity
 - Dispersion Diagramme for Waveguide
 - Iris-loaded Structures
 - Resonant Cavities
 - Rectangular and Cylindrical Cavities
 - Quality Factor of Resonator
 - Shunt Impedance and Energy Gain
 - Transit-Time Factor
 - Kilpatrick Limit
 - Software for Cavity Design
-

Group Velocity

- Energy (and information) travel with wave group velocity.
- Interference of two continuous waves of slightly different frequencies described by:

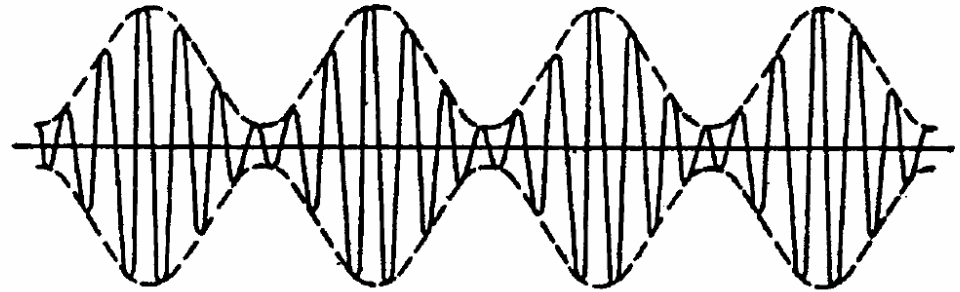

$$\begin{aligned} E &= E_0 \sin [(k + dk)x - (\omega + d\omega)t] + E_0 \sin [(k - dk)x - (\omega - d\omega)t] \\ &= E_0 \sin [kx - \omega t] \cos [dkx - d\omega t] \\ &= 2E_0 f_1(x, t) f_2(x, t) \end{aligned}$$

Group Velocity

- Mean wavenumber & frequency represented by continuous wave

$$f_1(x, t) = \sin [kx - \omega t]$$

- Any given phase in this wave is propagated such that $kx - \omega t$ remains constant.
- Phase velocity of wave is thus

$$v_p = -\frac{\partial f_1(x, t)/\partial t}{\partial f_1(x, t)/\partial x} = \frac{\omega}{k}$$

- Envelope of pattern described by

$$f_2(x, t) = \cos [dkx - d\omega t]$$

- Any point in the envelope propagates such that $x dt - t d\omega$ remains constant and its velocity, i.e. group velocity, is

$$v_g = -\frac{\partial f_2(x, t)/\partial t}{\partial f_2(x, t)/\partial x} = \frac{d\omega}{dk}$$

Dispersion Diagramme for Waveguide

- ❑ Description of wave propagation down a waveguide by plotting graph of frequency, ω , against wavenumber, $k = 2\pi/\lambda$
 - ❑ Imagine experiment in which signals of different frequencies are injected down a waveguide and the wavelength of the modes transmitted are measured.
 - ❑ Measurables
 - ❑ Phase velocity for given frequency: ω/k
 - ❑ Group velocity: slope of tangent
-

Dispersion Diagramme for Waveguide

Observations

- However small the k , the frequency is always greater than the cut-off frequency.
- The longer the wavelength or lower the frequency, the slower is the group velocity.
- At cut-off frequency, no energy flows along the waveguide.
- Also $v_{ph} v_g = c^2$

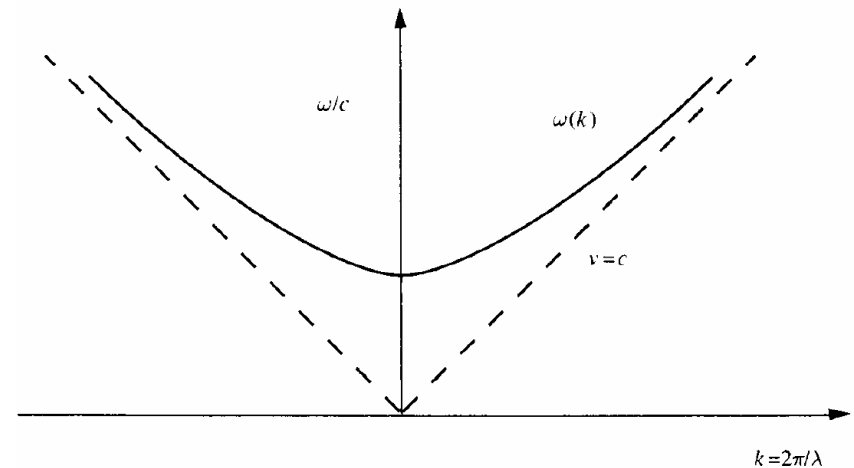

Dispersion diagramme for waveguide is the hyperbola

$$\left(\frac{\omega}{c}\right)^2 = k^2 + \left(\frac{\omega_c}{c}\right)^2$$

Iris-loaded Structures

- Acceleration in a waveguide is not possible as the phase velocity of the wave exceeds that of light.
 - Particles, which are travelling slower, undergo acceleration from the passing wave for half the period but then experience an equal deceleration.
 - Averaged over long time interval results in no net transfer of energy to the particles.
- Need to modify waveguide to reduce phase velocity to match that of the particle (less than speed of light).
- Install iris-shaped screens with a constant separation in the waveguide.

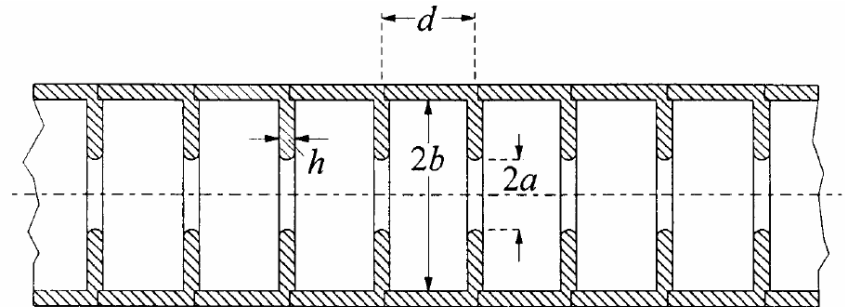

Iris-loaded Structures

- Recall that the dispersion relation in a waveguide is

$$\omega = c \sqrt{k_z^2 + \left(\frac{2\pi}{\lambda_c}\right)^2}$$

- With the installation of irises, curve flattens off and crosses boundary at $v_\phi = c$ at $k_z = \pi/2$

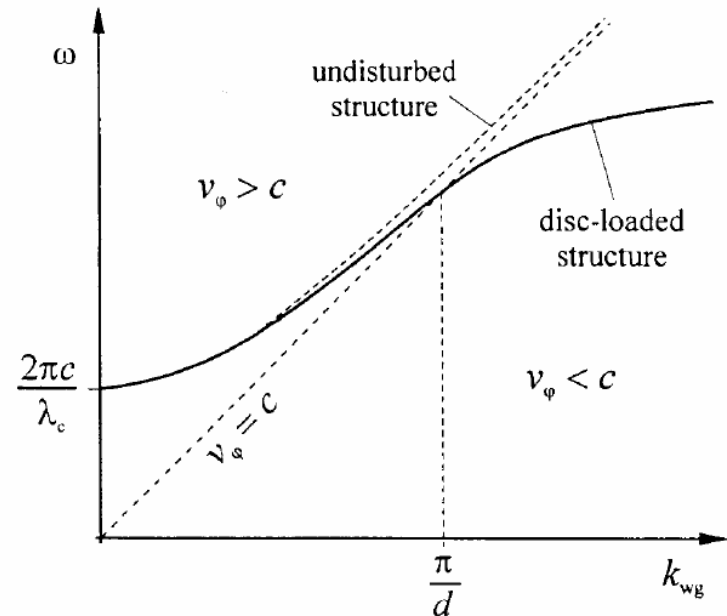

With suitable choice of iris separation d the phase velocity can be set to any value

Iris-loaded Structures

- ❑ Waveguides cannot be used for sustained acceleration as all points on dispersion curve lie above diagonal in dispersion diagramme.
- ❑ Phase velocity $> c$
- ❑ An iris-loaded structure slows down the phase velocity.

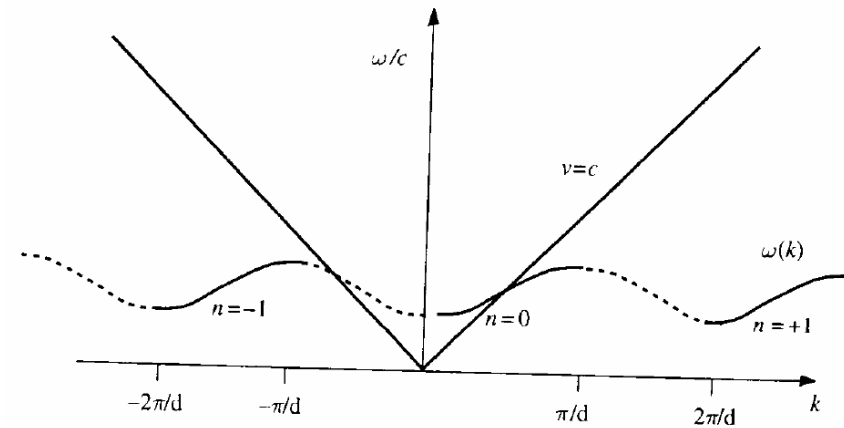

Dispersion diagramme
for a loaded waveguide

The k -value for each space harmonic is

$$k_n = k_0 + \frac{2n\pi}{d}$$

By choosing any frequency in dispersion diagramme it will intercept dispersion curve at k values spaced by $2n\pi/d$

First rising slope used for acceleration.

Resonant Cavities

- General solution of wave equation

$$W(r,t) = Ae^{i(\omega t + k \cdot r)} + Be^{i(\omega t - k \cdot r)}$$

- Describes sum of two waves – one moving in one direction and another in opposite direction

- If wave is totally reflected at surface then both amplitudes are the same, $A=B$, and

$$\begin{aligned} W(r,t) &= Ae^{i\omega t} (e^{ik \cdot r} + e^{-ik \cdot r}) \\ &= 2A \cos(k \cdot r) e^{i\omega t} \end{aligned}$$

- Describes field configuration which has a static amplitude $2A \cos(k \cdot r)$, i.e. a standing wave.

Resonant Cavities

■ Resonant Wavelengths

- Stable standing wave forms in fully-closed cavity if

$$l = q \frac{\lambda_z}{2} \quad \text{with} \quad q = 0, 1, 2, \dots$$

- where l = distance between entrance and exit of waveguide after being closed off by two perpendicular sheets.
- → only certain well-defined wavelengths λ_r are present in the cavity.

■ General resonant condition

$$\frac{1}{\lambda_r^2} = \frac{1}{\lambda_c^2} + \frac{1}{4} \left(\frac{q}{l} \right)^2$$

- Near the resonant wavelength, resonant cavity behaves like electrical oscillator but with much higher Q-value and corresponding lower losses of resonators made of individual coils and capacitors.
- Exploited to generate high-accelerating voltages

Rectangular Resonant Cavities

- Inserting

$$\left(\frac{2}{\lambda_c}\right)^2 = \left(\frac{m}{a}\right)^2 + \left(\frac{n}{b}\right)^2$$

into the resonance condition yields

$$\lambda_r = \frac{2}{\sqrt{\left(\frac{m}{a}\right)^2 + \left(\frac{n}{b}\right)^2 + \left(\frac{q}{l}\right)^2}} \quad \text{with } m, n, q = \text{integers}$$

- Integers $m, n,$ and q define modes in resonant cavity.

- Number of modes is unlimited but only a few of them used in practical situations.
 - $m, n,$ and q between 0 and 2

Cylindrical Resonant Cavities

- Inserting the expression for cut-off frequency into general resonance condition yields

$$\frac{1}{\lambda_r^2} = \left(\frac{x_1}{\pi D}\right)^2 + \frac{1}{4}\left(\frac{q}{l}\right)^2 \quad \text{with } q = 0, 1, 2, \dots$$

- where $x_1 = 2.0483$ is the first zero of the Bessel function.
- For the case of $q=0$, termed the TM_{010} mode, the resonant wavelength reduces to

$$\lambda_r = \frac{\pi D}{x_1}$$

Bessel Functions

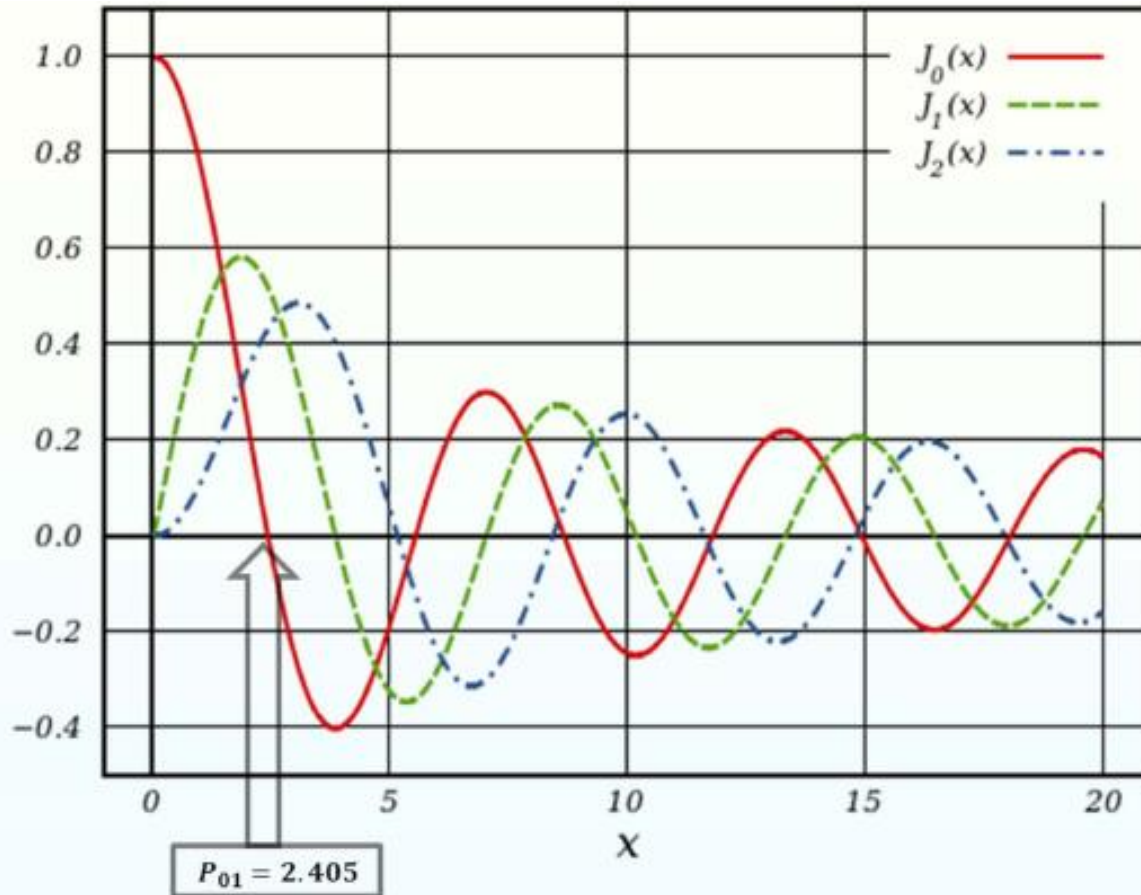

Pill-box Cylindrical Cavity

- The simplest RF cavity type
- The accelerating modes of this cavity are TM_{0lm}
 - Indices refer to the polar co-ordinates φ , r and z

Cylindrical pill-box cavity with holes for beam and coupler.

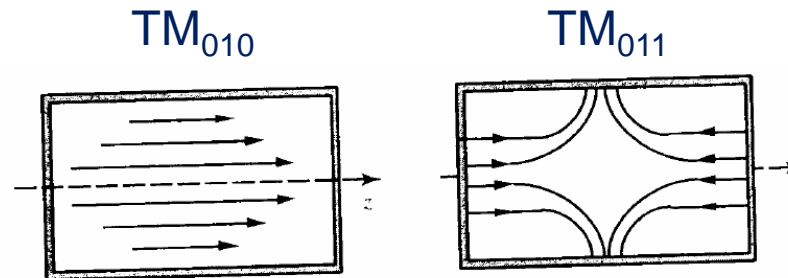
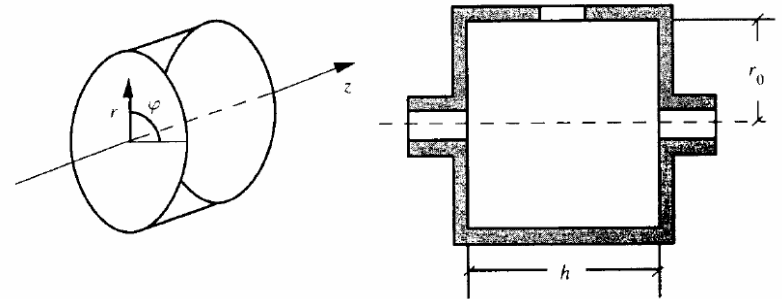

Lines of force for the electrical field.

Pill-box Cylindrical Cavity

- The modes with no φ variation are:

$$\nabla^2 E + \Lambda^2 E = 0$$

$$\frac{1}{r} \frac{\partial}{\partial r} \left(r \frac{\partial E}{\partial r} \right) + \frac{1}{r^2} \frac{\partial E}{\partial r} + \frac{\partial^2 E}{\partial z^2} + \Lambda^2 E = 0$$

$$E_z = E_0 J_0 \left(\frac{P_{0l}}{r_0} r \right) \cos \left(\frac{m\pi}{h} z \right)$$

$$E_r = E_0 \frac{m\pi}{P_{0l}} \frac{r_0}{h} J_1 \left(\frac{P_{0l}}{r_0} r \right) \sin \left(\frac{m\pi}{h} z \right)$$

$$\Lambda_{0lm}^2 = \left(\frac{P_{0l}}{r_0} \right)^2 + \left(\frac{m\pi}{h} \right)^2$$

- l indicates the radial variation while m controls the number of wavelengths in the z -direction.
- P_{0l} is the argument of the Bessel function when it crosses zero for the l th time.
 - $J_0(P_{0l}) = 0$ for $P_{0l} = 2.405$

Pill-box Cylindrical Cavity

- **TM₀₁₀ Mode**

$$E = E_0 J_0 \left(\frac{2.405}{r_0} r \right); \quad \Lambda_{010} = \frac{2.405}{r_0}; \quad \omega_{010} = \frac{\Lambda_{010}}{\sqrt{\epsilon\mu}}$$

$$v_{010} = \frac{\omega_{010}}{2\pi}; \quad \lambda_{010} = \frac{1}{v_{010} \sqrt{\epsilon\mu}}$$

Quality Factor of Resonator, Q

- Ratio of stored energy to energy dissipated per cycle divided by 2π

$$Q = \frac{W_s}{W_d} = \omega \frac{W_s}{P_d}$$

W_s = stored energy in cavity

W_d = energy dissipated per cycle divided by 2π

P_d = power dissipated in cavity walls

ω = frequency

Quality Factor of Resonator, Q

- Stored energy over cavity volume is

$$W_s = \frac{\epsilon_0}{2} \int |E|^2 dv$$

$$W_s = \frac{\mu_0}{2} \int |H|^2 dv$$

where the first integral applies to the time the energy is stored in the E -field and the second integral as it oscillates back into the H -field.

Quality Factor of Resonator, Q

- ❑ Losses on cavity walls are introduced by taking into account the finite conductivity σ of the walls.
- ❑ Since, for a perfect conductor, the linear density of the current j along walls of structure is

$$\mathbf{j} = \mathbf{n} \times \mathbf{H}$$

we can write

$$P_d = \frac{R_{surf}}{2} \int_s |\mathbf{H}|^2 ds \quad \text{with } s = \text{inner surface of conductor}$$

Quality Factor of Resonator, Q

R_{surf} = surface resistance

δ = skin depth

$$R_{\text{surf}} = \sqrt{\frac{\pi f \mu_0 \mu_r}{\sigma}} = \frac{1}{\sigma \delta}$$

For Cu, $R_{\text{surf}} = 2.61 \times 10^{-7} \sqrt{\omega} \ \Omega$

Shunt Impedance - R_s

- Figure of merit for an accelerating cavity
 - Relates accelerating voltage to the power P_d to be provided to balance the dissipation in the walls.
- Voltage along path followed by beam in electric field E_z is

$$V = \int_{\text{path}} |E_z(x,y,z)| dl$$

from which (peak-to-peak)

$$R_s = \frac{V^2}{2P_d}$$

Shunt Impedance - R_s

$$R_s = 5.12 \times 10^8 \frac{\beta_z (1-\eta)^2}{p + 2.61\beta_z (1-\eta)} \left(\frac{\sin D/2}{D/2} \right)^2$$

with

$$\beta_z \equiv \frac{v_\phi}{c} \text{ (phase velocity)}$$

$$\eta \equiv \frac{h}{d} \text{ (} h = \text{thickness, } d = \text{iris separation)}$$

$p \equiv$ number of irises per wave length (equal to mode number)

$$D \equiv \frac{2\pi}{p} (1-\eta)$$

Energy Gain

- Energy gain of particle as it travels a distance through linac structure depends only on potential difference crossed by particle:

$$U = K \sqrt{P_{RF} l R_s}$$

where

P_{RF} \equiv supplied RF power

l \equiv length of linac structure

R_s \equiv shunt impedance

K \equiv correction factor (≈ 0.8)

Analogous to Electrical Oscillator

- Cavity behaves as an electrical oscillator but with very high quality factor (sharp resonance)

$$Q = \frac{\omega_r}{\Delta\omega} = \frac{R_s}{Z}$$

ω_r resonant frequency

$\Delta\omega$ = frequency shift at which amplitude is reduced by -3 dB relative to resonance peak

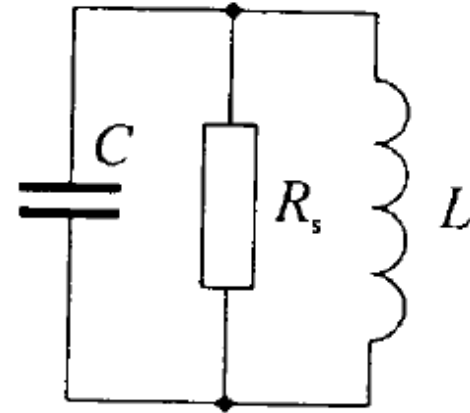

Electrical response of cavity described by parallel circuit containing C, L, and R_s

On resonance the impedance is

$$Z = \omega L = \frac{1}{\omega C}$$

Transit-Time Factor

- Accelerating gap
 - Space between drift tubes in linac structure
 - Space between entrance and exit orifices of cavity resonator
- Field is varying as the particle traverses the gap
 - Makes cavity less efficient and resultant energy gain which is only a fraction of the peak voltage

The RF Gap

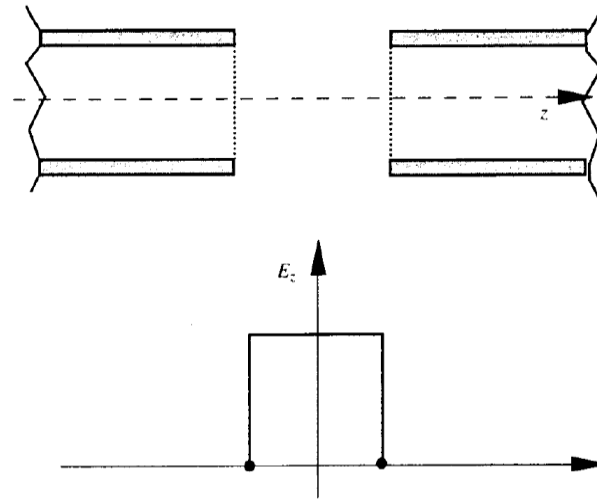

$$E_z = E_0 \cos(\omega t + \phi)$$

Field is uniform along gap axis and depends sinusoidally on time

Phase ϕ refers to particle in middle of gap $z=0$ at $t=0$

Transit-Time Factor

- Transit-Time Factor is ratio of energy actually given to a particle passing the cavity centre at peak field to the energy that would be received if the field were constant with time at its peak value
- The energy gained over the gap G is:

$$V = \int_{-G/2}^{+G/2} E_0 \cos(\omega t + \varphi) dz = \frac{\sin(\omega G / 2 \beta c)}{\omega G / 2 \beta c} (E_0 G \cos \varphi)$$

Transit-Time Factor

The Transit Gap Factor is defined as

$$\text{Transit Gap Factor } \Gamma \equiv \frac{\sin(\omega G / 2\beta c)}{\omega G / 2\beta c}$$

Defining a transit angle

$$\text{Transit Angle } \equiv \theta = \omega G / \beta c = 2\pi G / \beta \lambda$$

the Transit Gap Factor becomes

$$\Gamma = \frac{\sin \theta / 2}{\theta / 2} \quad \text{with } 0 < \theta < 1$$

The Transit-Time Factor

□ Observations

- At relativistic energies, cavity dimensions are comparable with $\lambda/2$

- Reduction in efficiency due to transit-time factor is acceptable.

□ At low energies, this is not the case

- Cavities have strange re-entrant configuration to keep G short compared to dimensions of its resonant volume.

The Transit-Time Factor

- ❑ Compromise cavity design
 - ❑ Increasing ratio of volume/surface area
 - ❑ Reduces ohmic losses
 - ❑ Increases Q factor
 - ❑ Minimise gap factor

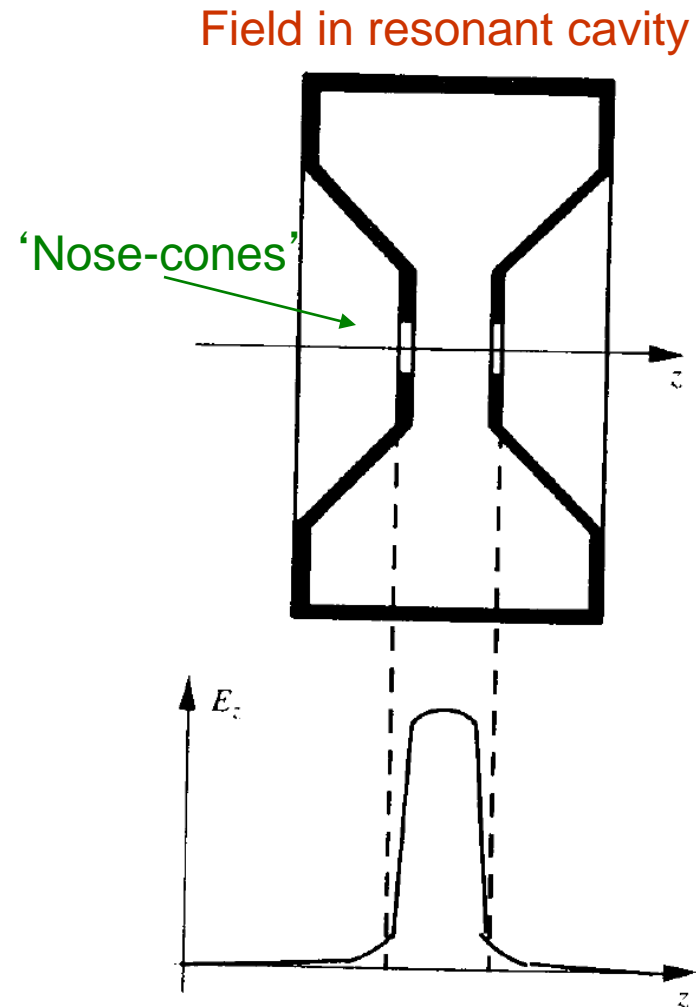

Kilpatrick Limit

- RF breakdown observed at very high fields.
- Kilpatrick Limit expresses empirical relation between accelerating frequency and E-field
 - $f = 1.64 E_k^2 e^{-8.5 / E_k}$

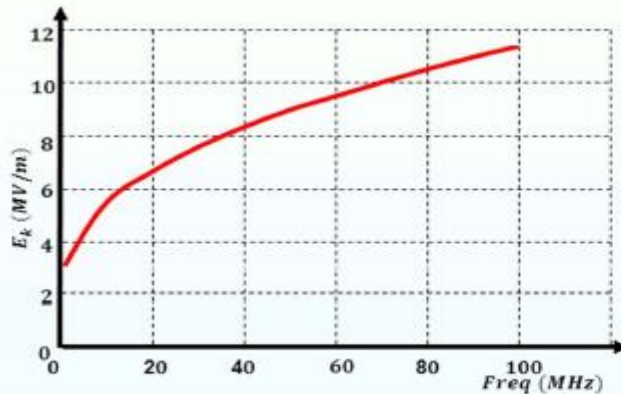

Software for Cavity Design

- Poisson and Superfish are the main solver programs in a collection of programs from LANL for calculating static magnetic and electric fields and radio-frequency electromagnetic fields in either 2-D Cartesian coordinates or axially symmetric cylindrical coordinates.
- Finite Element Method



Solvers:

- **Automesh** – generates the mesh (always the first program to run)
- **Fish** – RF solver
- **Cfish** – version of Fish that uses complex variables for the rf fields, permittivity, and permeability.
- **Poisson** – magnetostatic and electrostatic field solver
- **Pandira** – another static field solver (can handle permanent magnets)
- **SFO, SF7** – postprocessing
- **Autofish** – combines Automesh, Fish and SFO
- **DTLfish, DTLCells, CCLfish, CCLcells, CDTfish, ELLfish, ELLCAV, MDTfish, RFQfish, SCCfish** – for tuning specific cavity types.
- **Kilpat, Force, WSFPlot**, etc.

- http://laacg1.lanl.gov/laacg/services/download_sf.phtml

Structures usually solved by Finite Element Analysis