

Digital Hadron Calorimetry
Using
Gas Electron Multiplier Technology

CALICE Meeting, NIU

March 2005

Andy White

(for the GEM-DHCAL group:

UTA, U.Washington, Tsinghua U.)

Goals of DHCAL/GEM Project

- * Design and construct a Linear Collider Detector calorimeter system based on GEM technology.
- * Build/study GEM systems.
- * Define operational characteristics of GEM system.
- * Understand DHCAL/GEM systems in terms of proposed LC detector design concepts.
- * Construct full size test beam module and beam test.
- * Use test beam results to develop PFA for GEM-based DHCAL.
- * Develop full DHCAL/GEM calorimeter system design.

Digital Hadron Calorimetry

Physics requirements emphasize segmentation/granularity (transverse AND longitudinal) over intrinsic energy resolution.

- Depth $\geq 4\lambda$ (not including ECal $\sim 1\lambda$) + tail-catcher(?)

- *Assuming PFlow:*

- sufficient segmentation (**#channels**) to allow efficient charged particle tracking.

- for "digital" approach - sufficiently fine segmentation (**#channels**) to give linear energy vs. hits relation

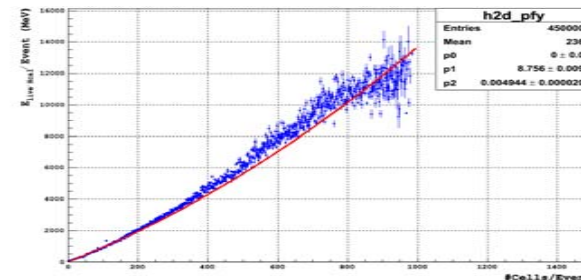
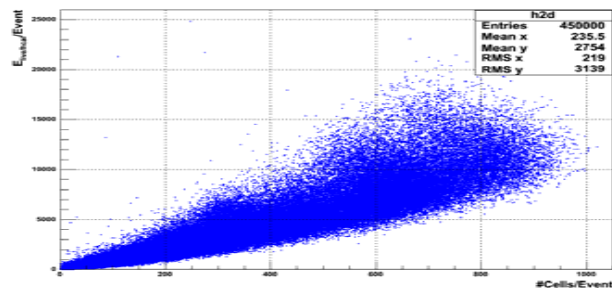

- efficient MIP detection (**threshold, cell size**)

- intrinsic, single (neutral) hadron energy resolution must not degrade jet energy resolution.

GEM-based Digital Calorimeter Concept

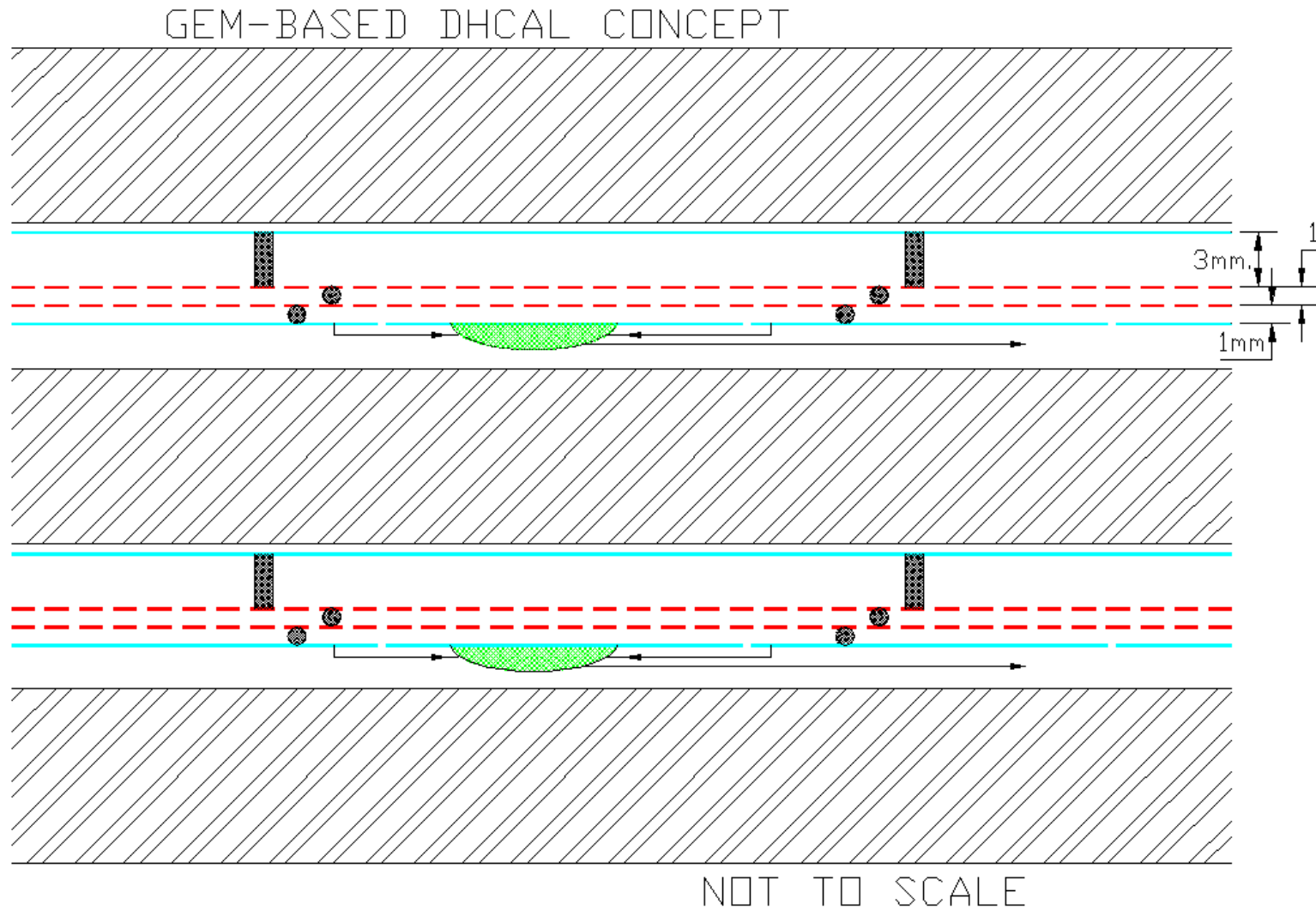

GEM - principle of operation

GEM foil etching

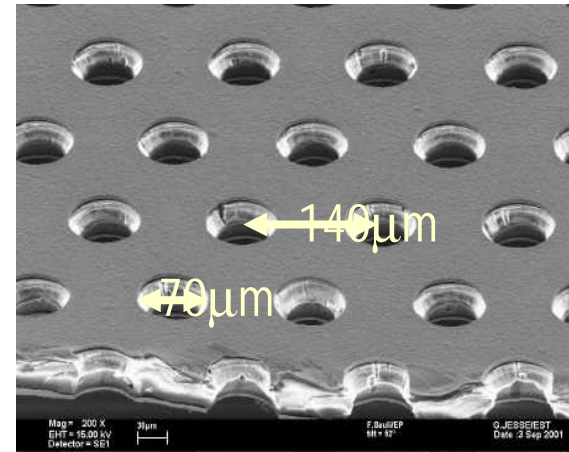

GEM field and multiplication

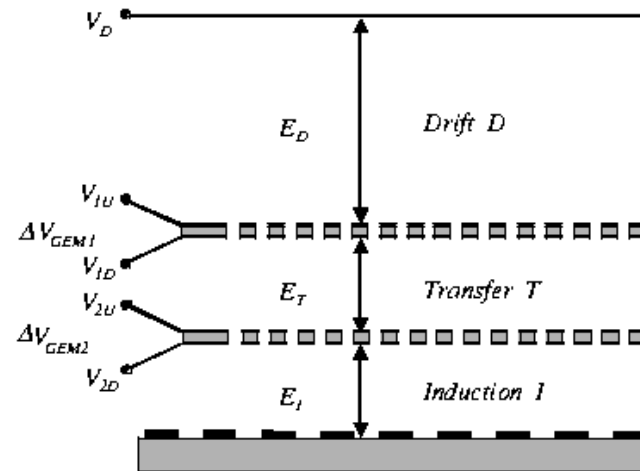
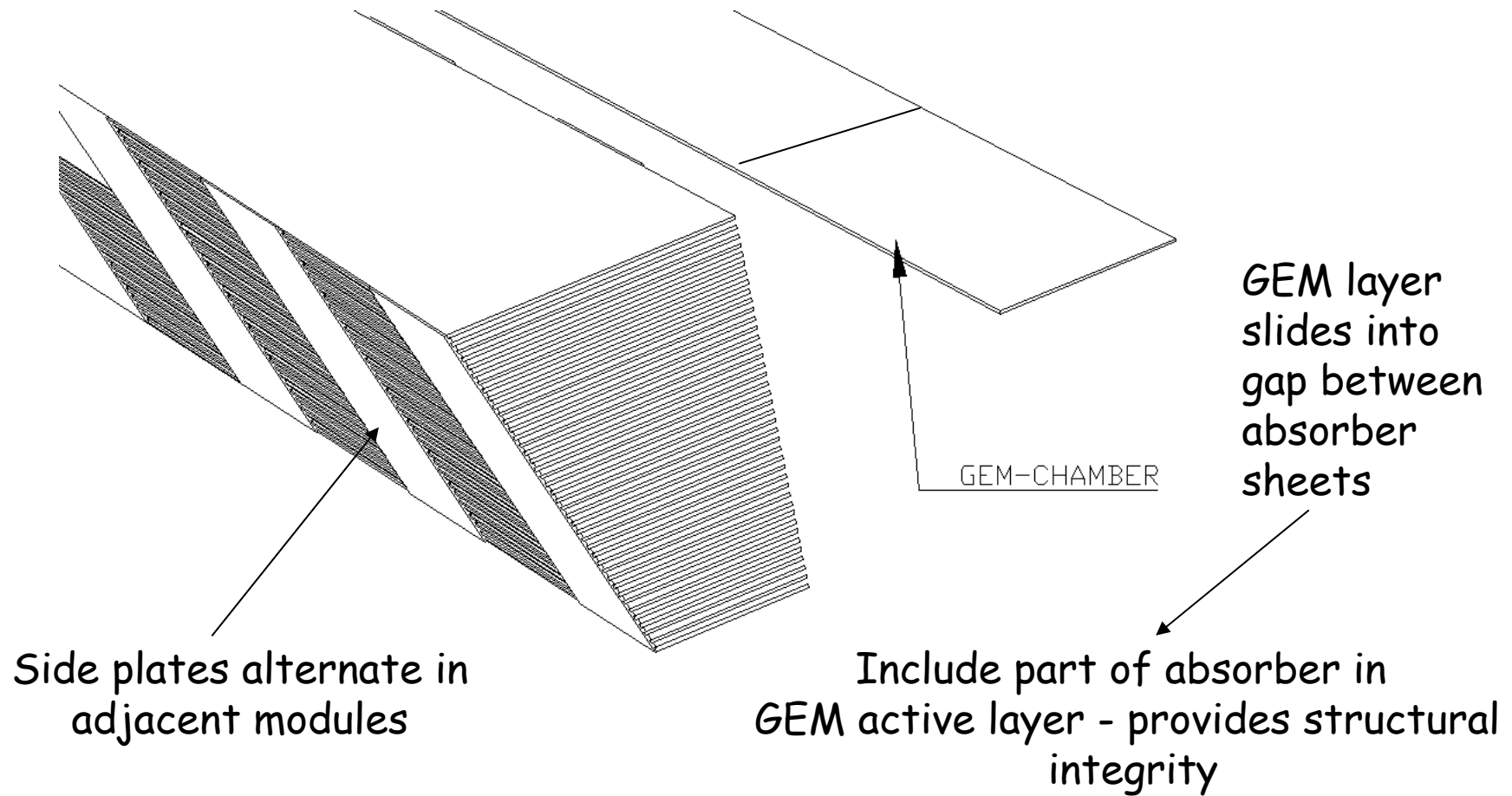

Fig. 1: Schematics of a double-GEM detector.

From CERN-open-2000-344, A. Sharma

DHCAL/GEM Module concepts



GEM system development

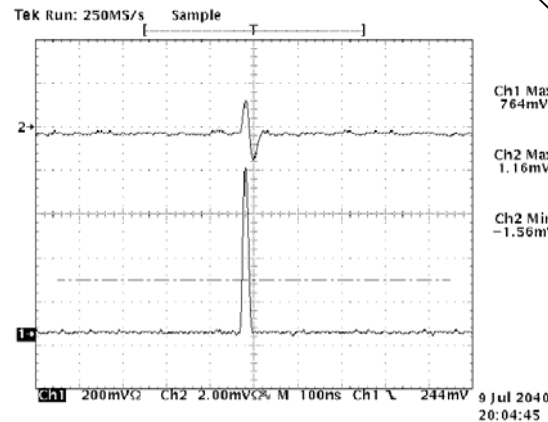
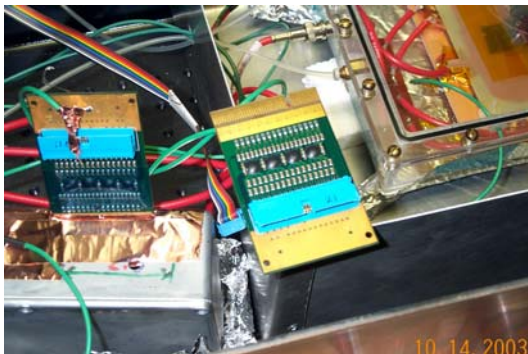
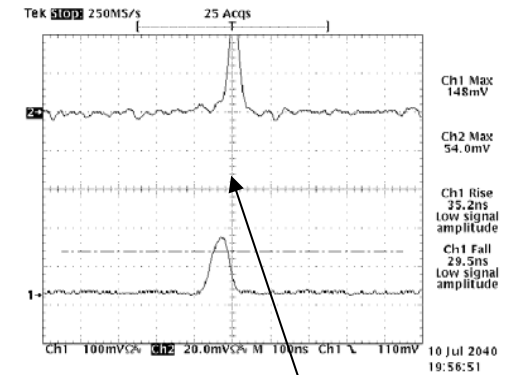
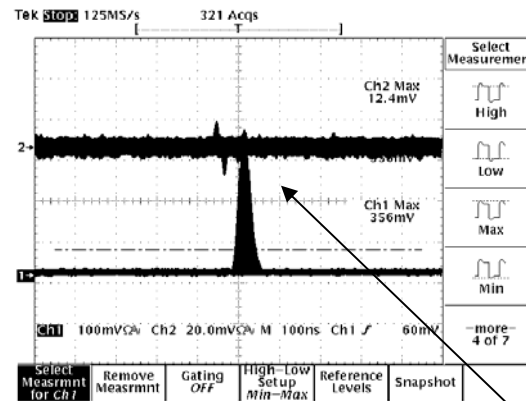
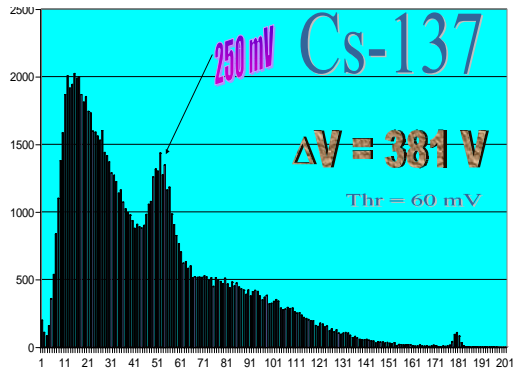
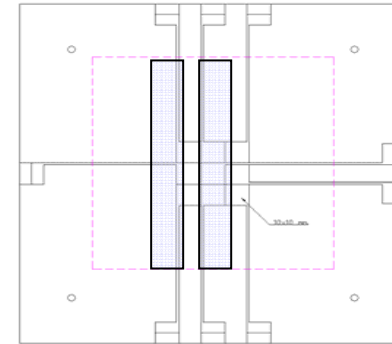
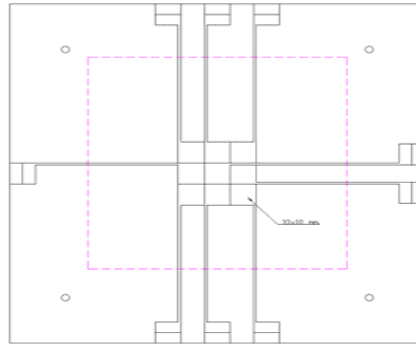
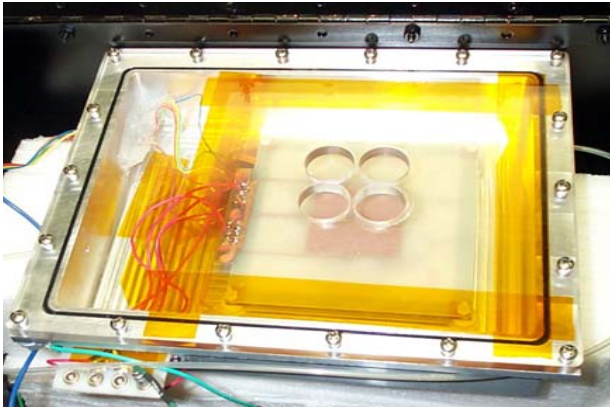

Signal sharing and crosstalk studies

GEM - gas mixture/gain studies

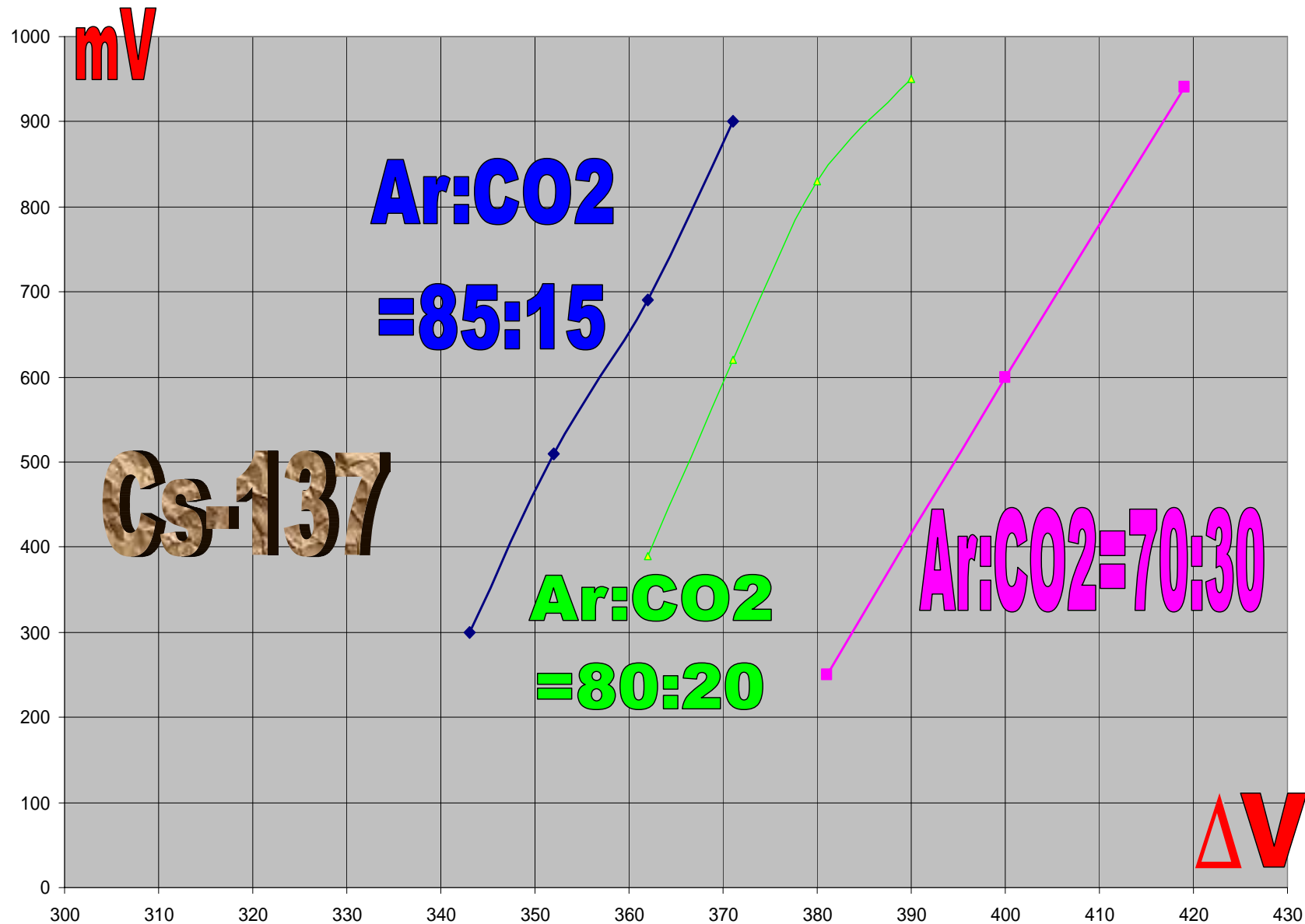

GEM/DHCAL signal sizes

Goal: Estimate the minimum, average and maximum signal sizes for a cell in a GEM-based digital hadron calorimeter.

Method: Associate the average total energy loss of the Landau distribution with the total number of electrons released in the drift region of the GEM cell.

Ionization in the GEM drift region

A charged particle crossing the drift region will have a discrete number of "primary" ionizing collisions (ref. F.Sauli, CERN 77-09, 1977).

An ejected electron can have sufficient energy to produce more ionization. The sum of the two contributions is referred to as the "total ionization". In general,

$$n_T = n_p * 2.5$$

Using Sauli's table, we calculate $n_T = 93.4$ ion pair/cm for Ar/CO₂ 80/20 mixture.

Characteristics of the Landau energy loss distribution

The Landau distribution is defined in terms of the normalized deviation from the "most probable energy loss", which is associated with the peak of the distribution - see the following slide.

The average total energy loss occurs at about 50% of the peak (on the upper side). This is the point we associate with the quantity n_T .

In order to set a value for the minimum signal, we need to choose a point on the low side of the peak corresponding to a certain expected efficiency. From our GEM simulation, we find that we expect a 95% efficiency with a threshold at ~40% of the peak value - result from simulation (J.Yu, V.Kaushik, UTA)

Typical Landau curve

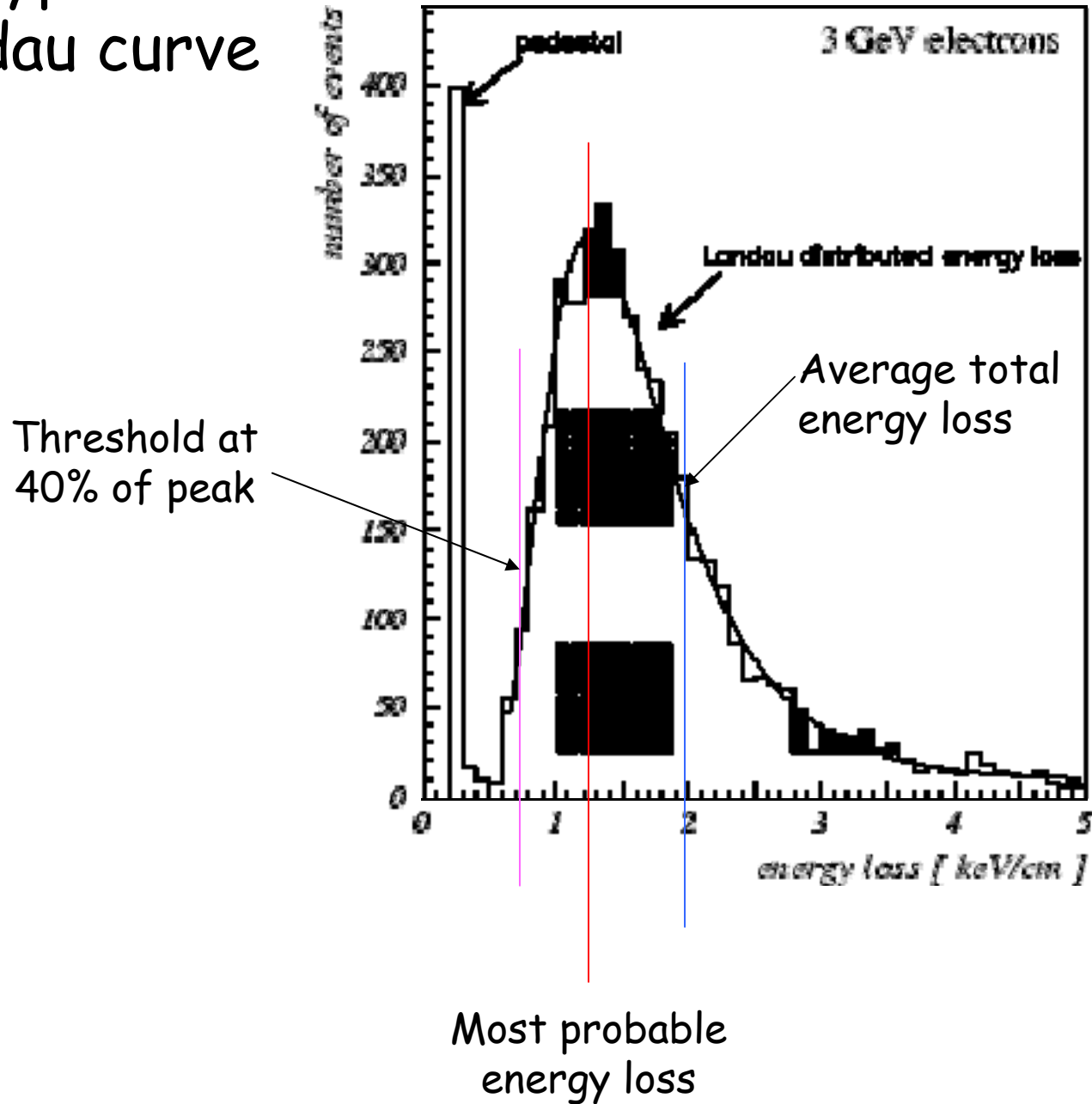

GEM/DHCAL MIP Efficiency - simulation

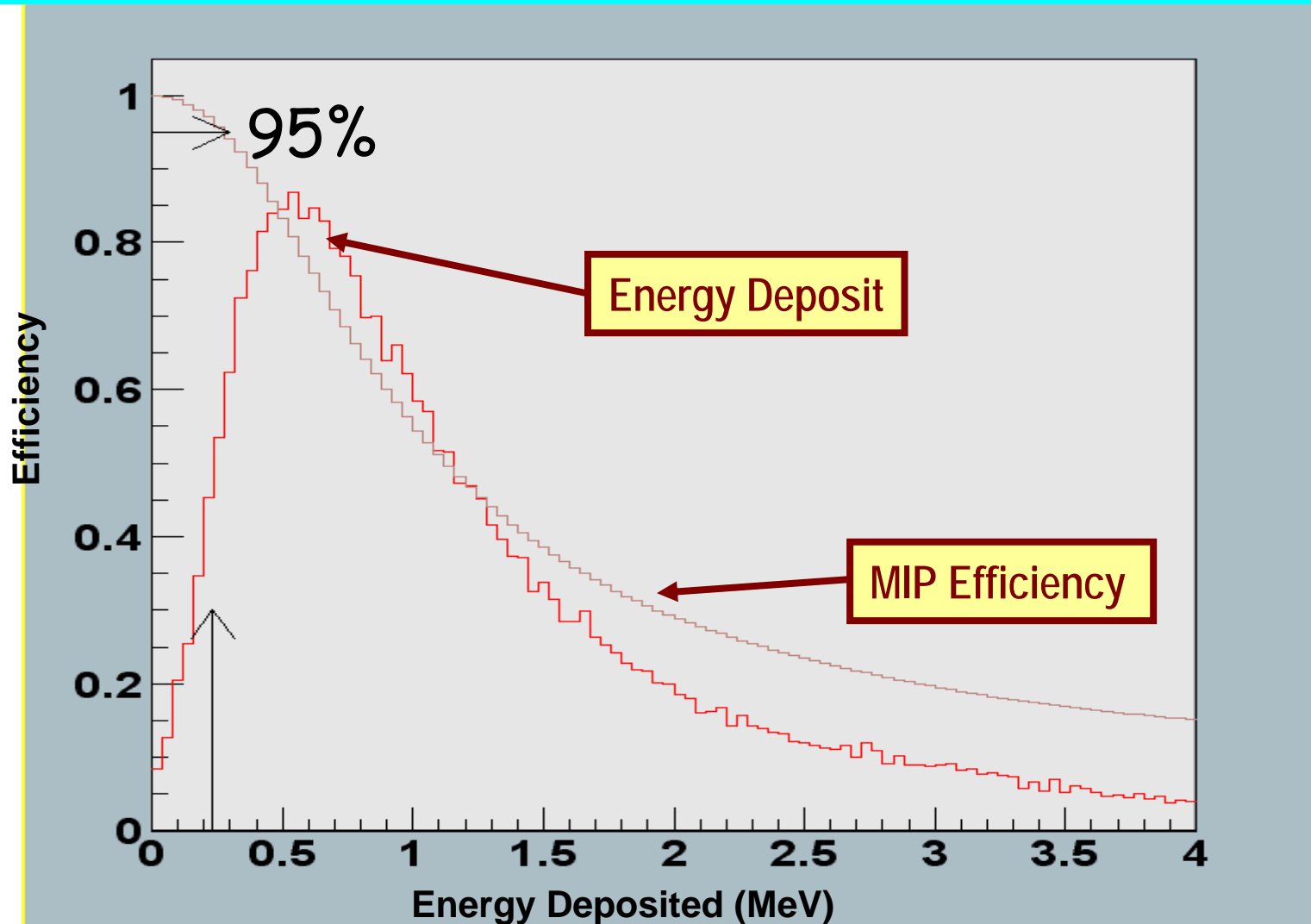

Calculating our GEM signal levels

Looking at the following slide for Ar/CO₂ 80/20 we see that the average total energy loss occurs at a signal size that is ~5x that for a minimum signal at 40% of the peak height on the low side of the peak.

So then, if $n_T = 93.4$ ion pair/cm, then we expect ~28 total electrons on the average per MIP at normal incidence on our 3mm drift region. This gives 5.6 electrons for the minimum signal.

The gain we measured for our 70/30 mixture was ~3500, and we see a factor x3 for 80/20 (see following plot). Putting this all together, we expect

$$\begin{aligned} \text{Minimum signal size} &= 5.6 \times 3,500 \times 3 \times 1.6 \times 10^{-19} \\ &= 10 \text{ fC} \end{aligned}$$

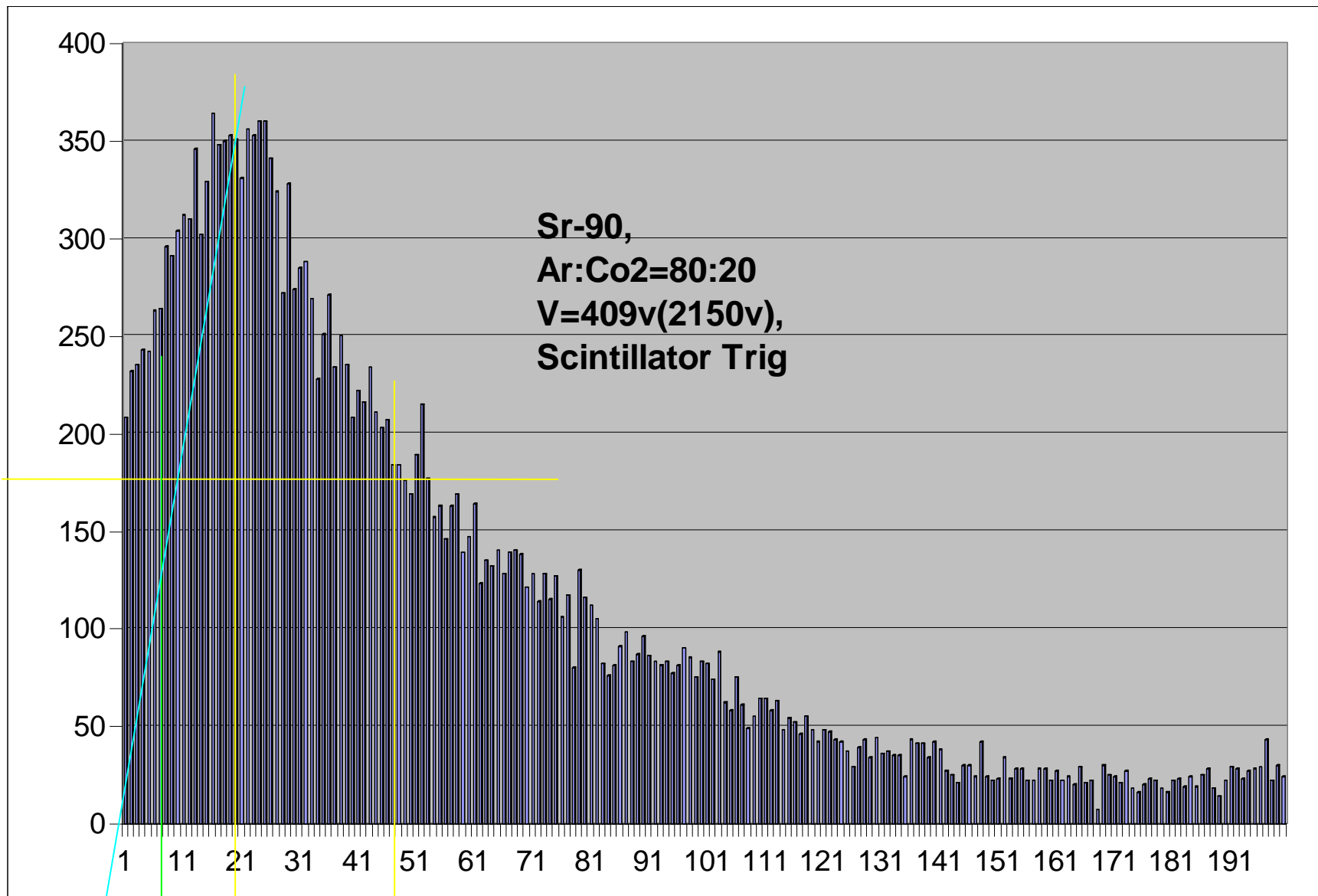

Threshold

Most
probable

Average

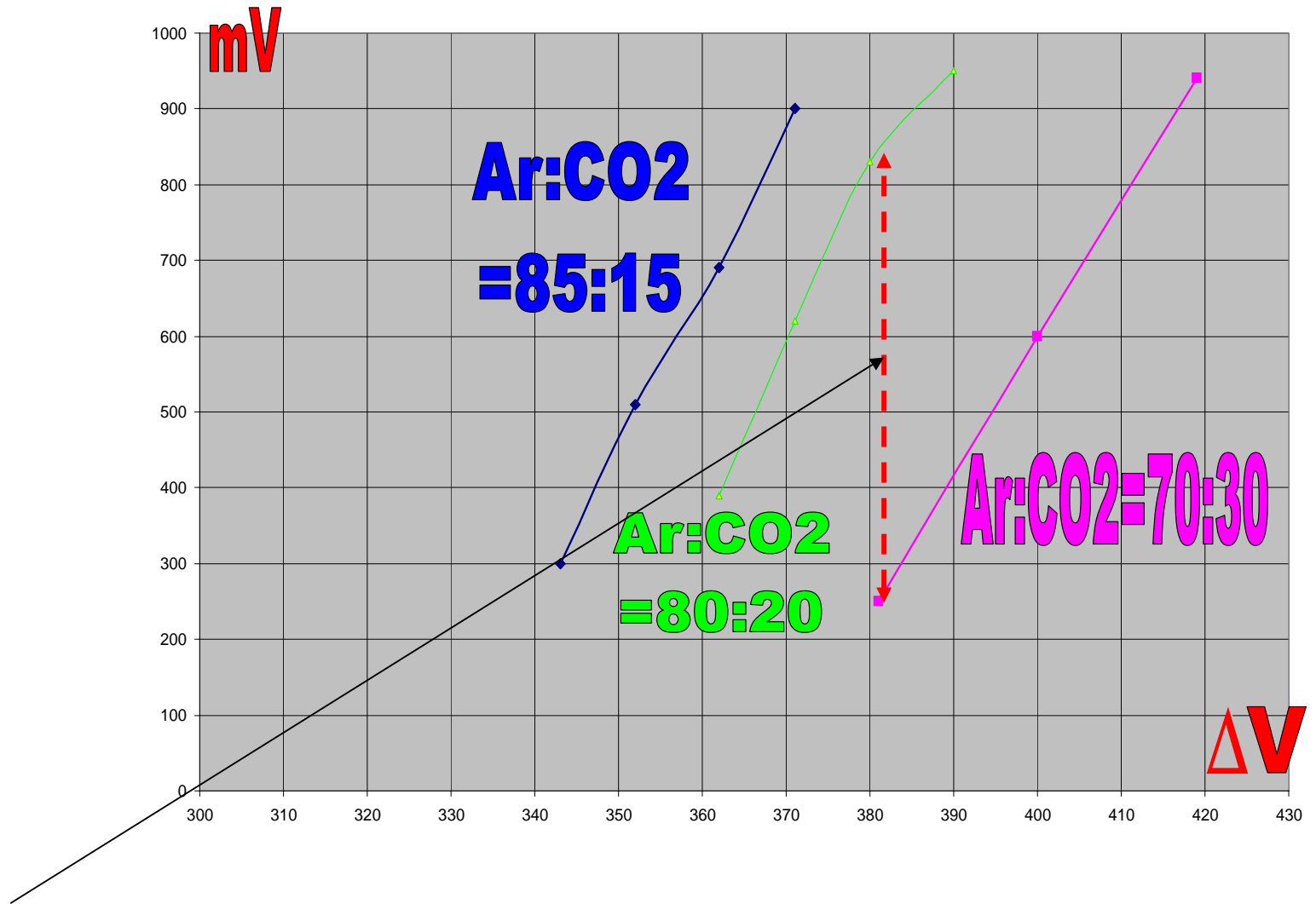

~ factor of 3 increase in signal at same voltage for 80:20 vs 70:30

Calculating our GEM signal levels

We also expect:

Most probable signal size $\sim 20 \text{ fC}$

Average signal size $\sim 50 \text{ fC}$

These estimates are essential input to the circuit designers for the RPC/GEM ASIC front-end readout.

The estimate of the maximum signal size requires input from physics (+background(s)) simulation...

GEM Efficiency Measurement

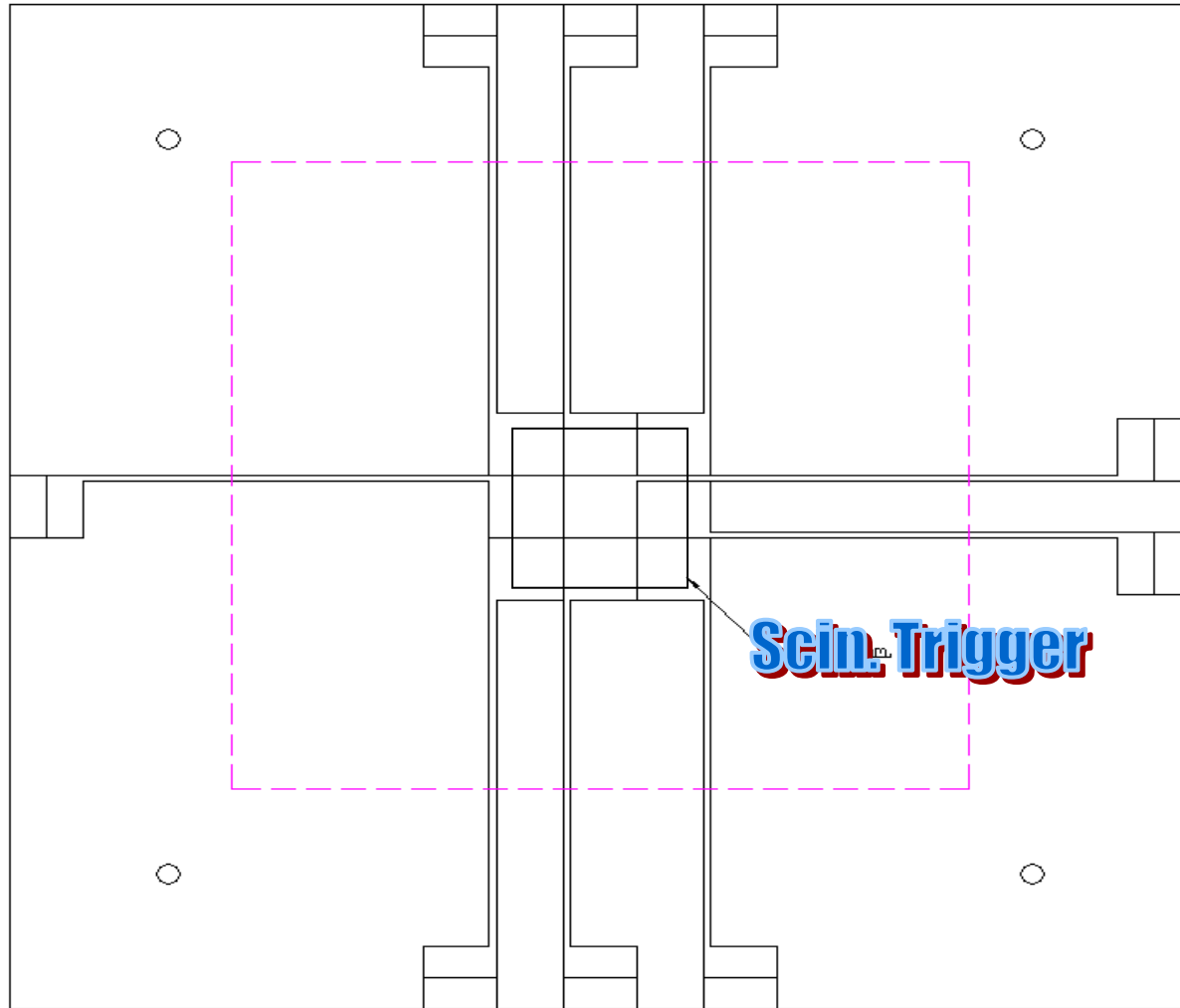

Setup for 9-pad GEM efficiency measurement

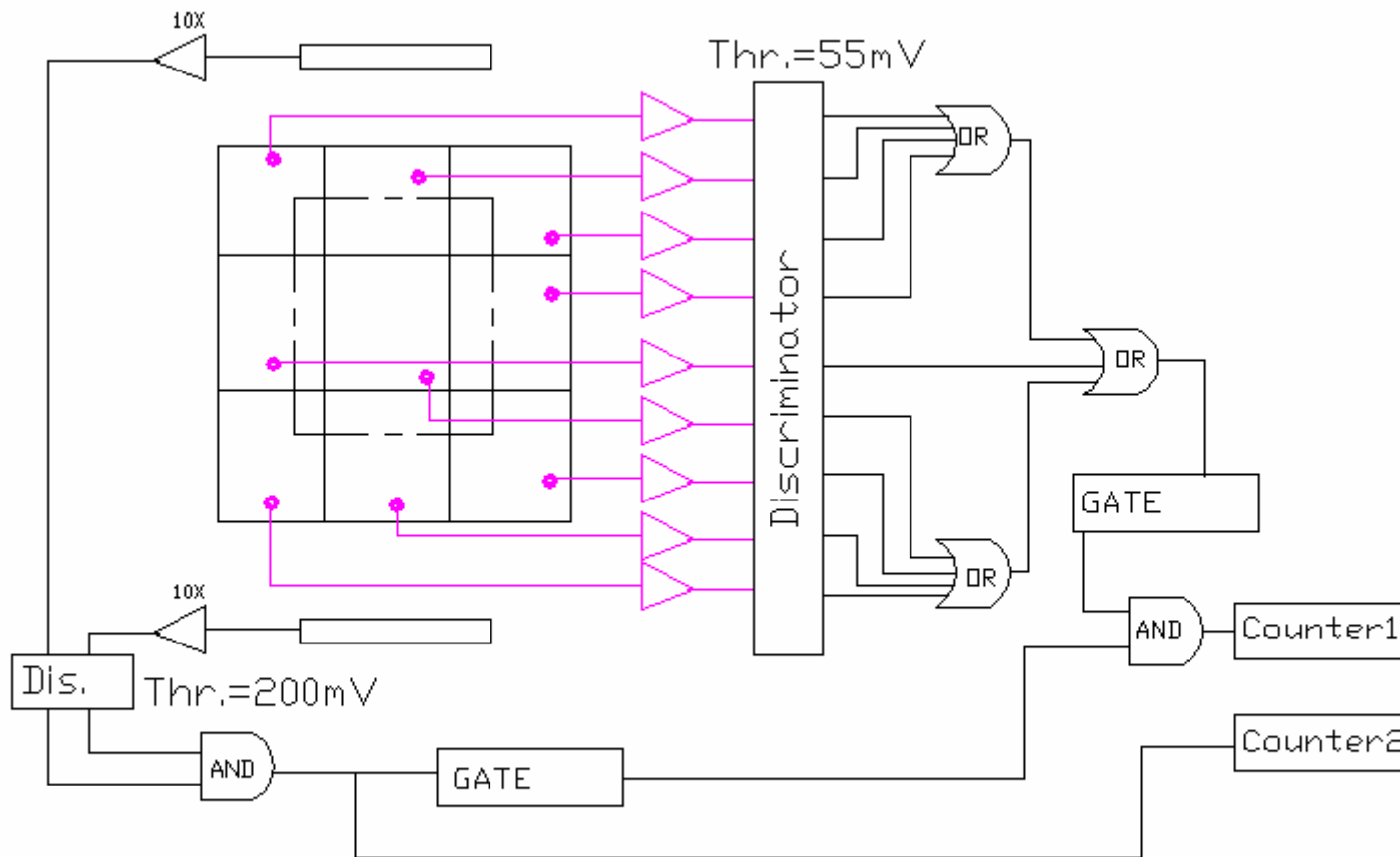

GEM efficiency measurement using cosmic rays

Eff. = 94.6%

after ensuring that
cosmics must hit a pad

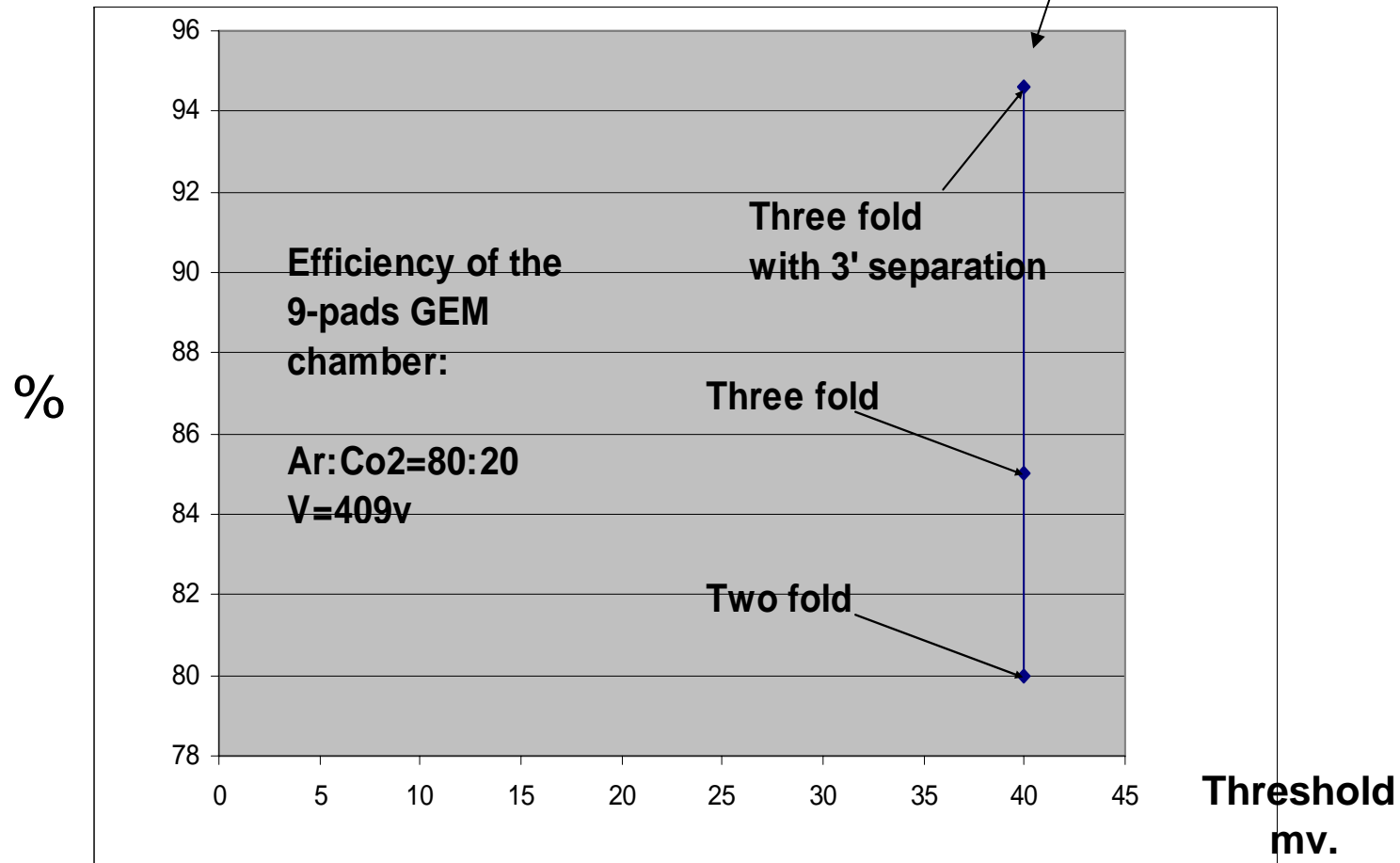

GEM Multiplicity Measurements

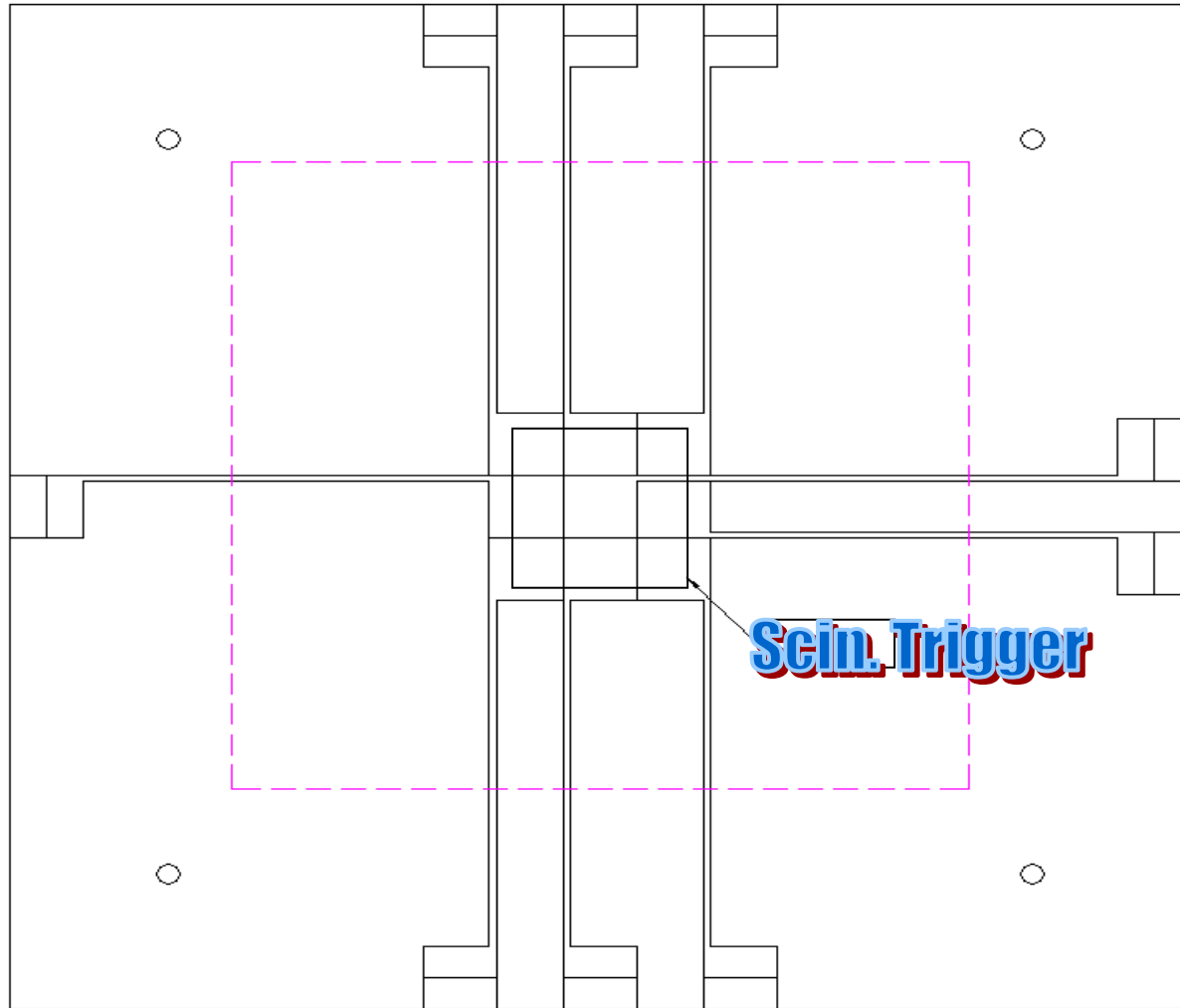

GEM Multiplicity Measurement

- 9-pad (3x3) GEM Chamber - double GEM
- Ar/CO₂ 80:20
- HV = 409V across each GEM foil
- Threshold 40mV -> 95% efficiency
- Sr-90 source/scintillator trigger

-> Result: **Average multiplicity = 1.27**

Exploiting the Time Structure of Energy Depositions in HCal ?

- Hadronic signal has a time-distributed structure:
 - > π , K, p,... prompt signal
 - > neutrons - delayed deposition(s) - *if* active medium is sensitive to neutrons
- Integrated energy deposition?
- **Can we exploit this structure??**
- Why? For complex energy deposition pattern -> time separation could reveal e.g. neutron component -> do NOT add these depositions to charged clusters, which would lead to mis-measurement.
- Direct neutrons vs. shower neutrons?

Exploiting the Time Structure of Energy Depositions in HCal ?

- What are the fluctuations (in time) of the prompt vs. delayed depositions from shower to shower?
- If the fluctuations are not too large, what precision do we need/can we achieve on the timing?
- How do we implement the timing?
- What is the time structure for gaseous calorimeters (vs. e.g. scintillator)?
- Is it worth doing? Results vs. extra cost?
- Need some simulation studies...? WORK!

Plans for next GEM assemblies

- Produce and use **larger GEM foils**.
- Intermediate step towards full-size foils for test beam.
- Present 3M process allows ~30cm x 30cm foil production.
- Order has been placed for foils - delivery in 1-2 months.
- Assemble 5 layers of DGEM chambers - Spring 2005.

Cosmic stack using Double GEM counters

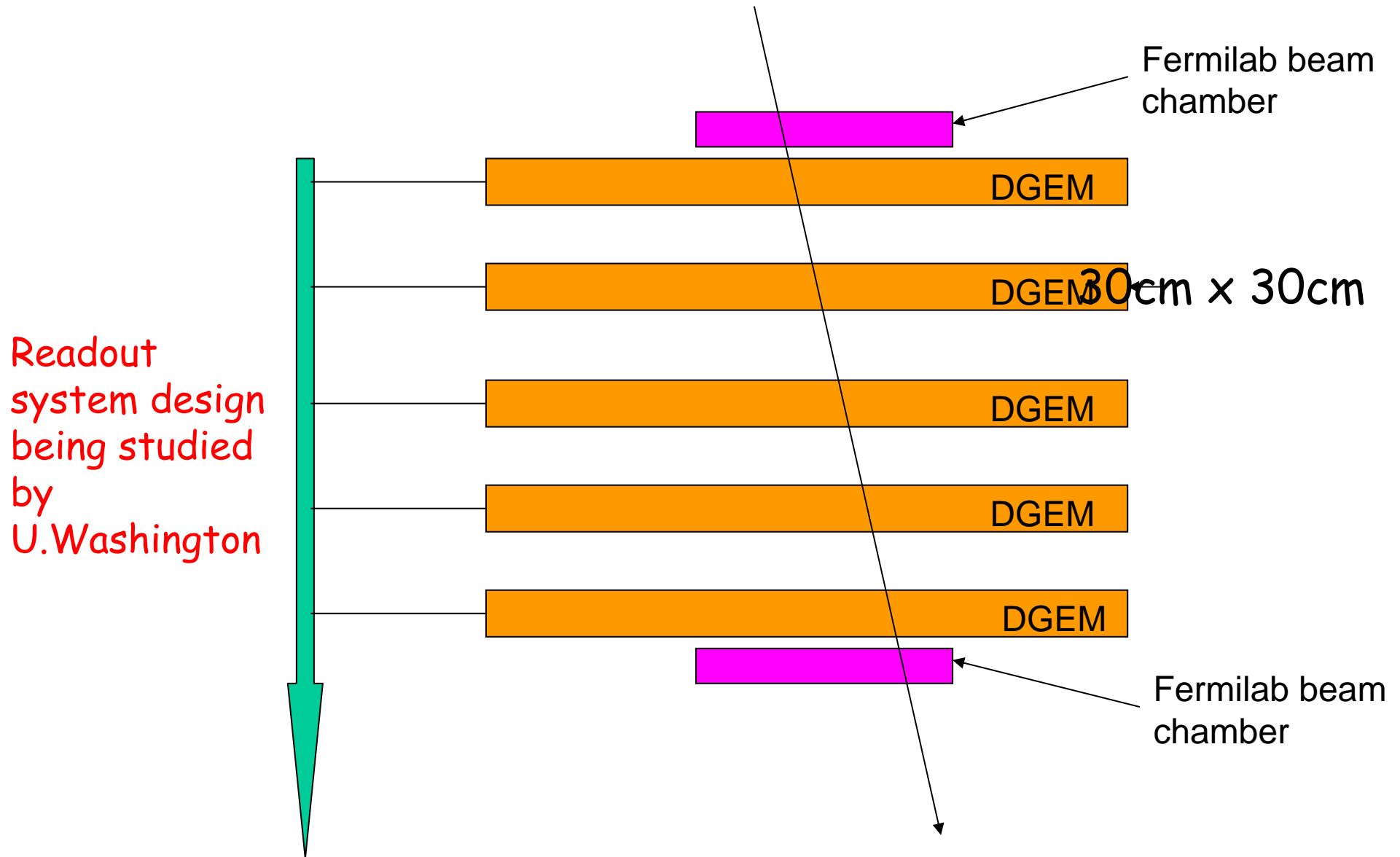

Cosmic stack using Double GEM counters

- Single cosmic tracks.
- Hit multiplicity (vs. simulation)
- Signal sharing between pads (e.g. vs. angle)
- Efficiencies of single DGEM counters
- Effects of layer separators
- Operational experience with ~500 channel system
- Possible test-bed for ASIC when available - rebuild one or more DGEM chambers.

T2K large GEM foil design

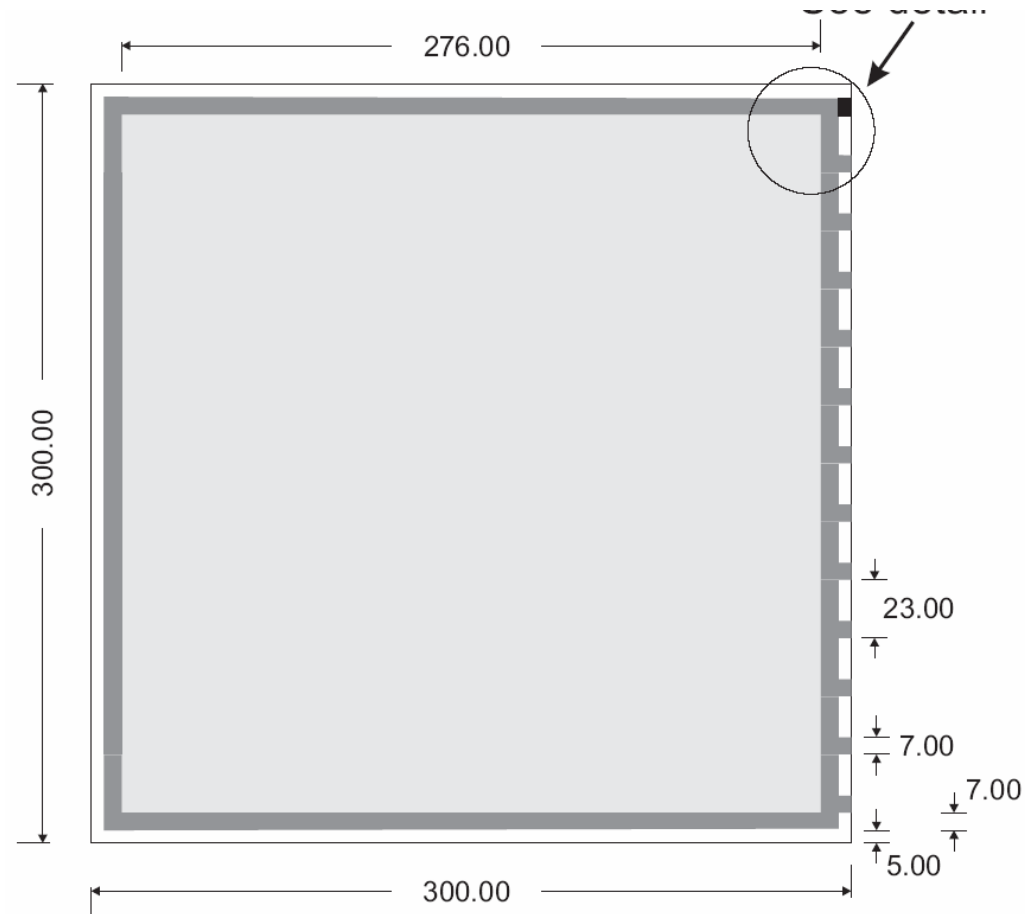

(Close to COMPASS(CERN) foil design)

T2K large GEM foil design

Institutes cooperating on foil production:

- U. Victoria BC (Canada) (T2K and LC TPC)
- U. Washington (DHCAL)
- Louisiana Tech. U. (LC TPC)
- Tsinghua U. (DHCAL)
- IHEP Beijing (GEM development)
- U. Texas Arlington (DHCAL)

(share cost of masks, economy of scale in foil production)

Front side detail

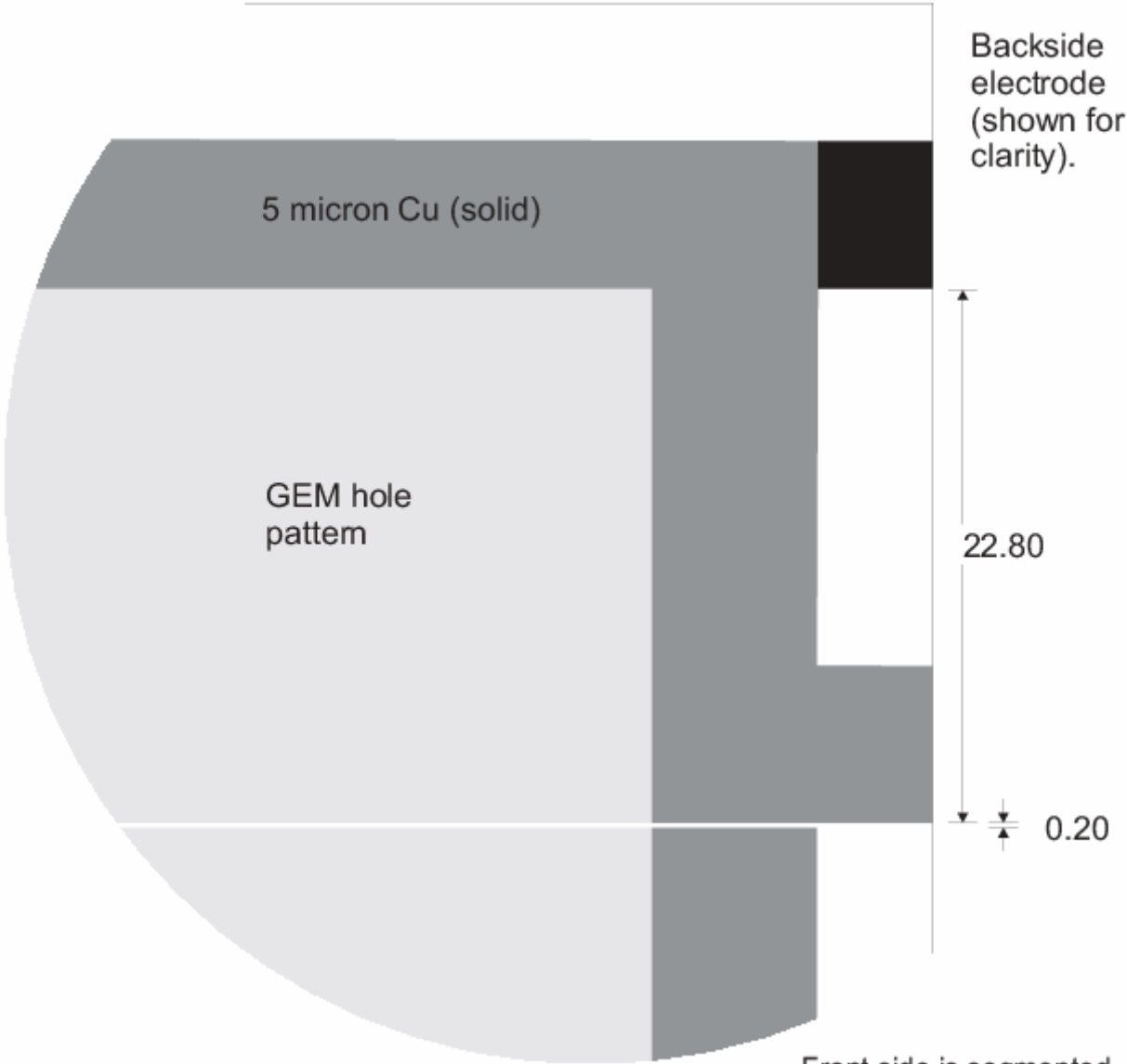

Front side is segmented into 12 isolated sections with 0.20 mm separation

305mm x 305mm layer

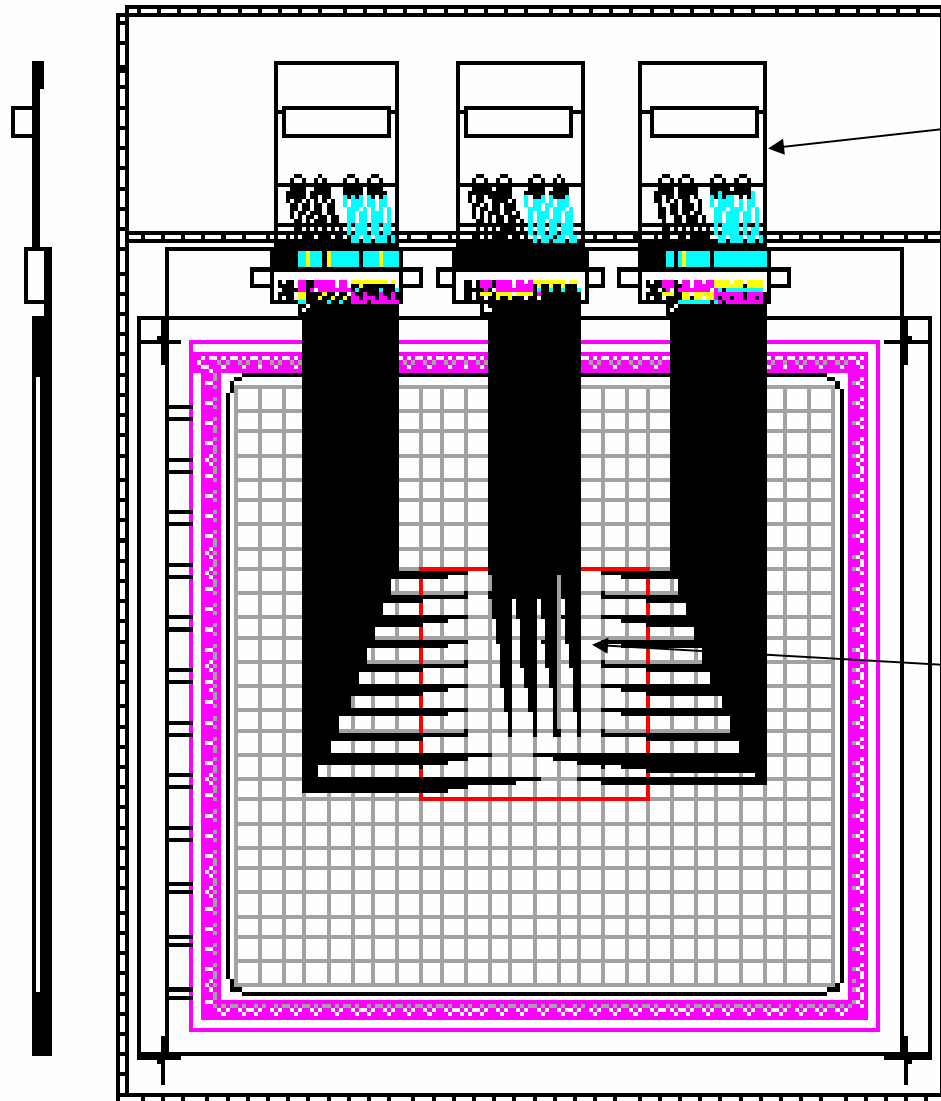

Trace edge
connector ->
Fermilab 32 ch
board - **new**
production by
Fermilab PPD
Electronics

$(10 \times 10) - 4 =$
96 pad active
area

Development of large-scale GEM layer for final test beam stack

Test beam stack will be 1m^3 , with 40 active layers each $\sim 8\text{mm}$ thick between steel absorber plates.

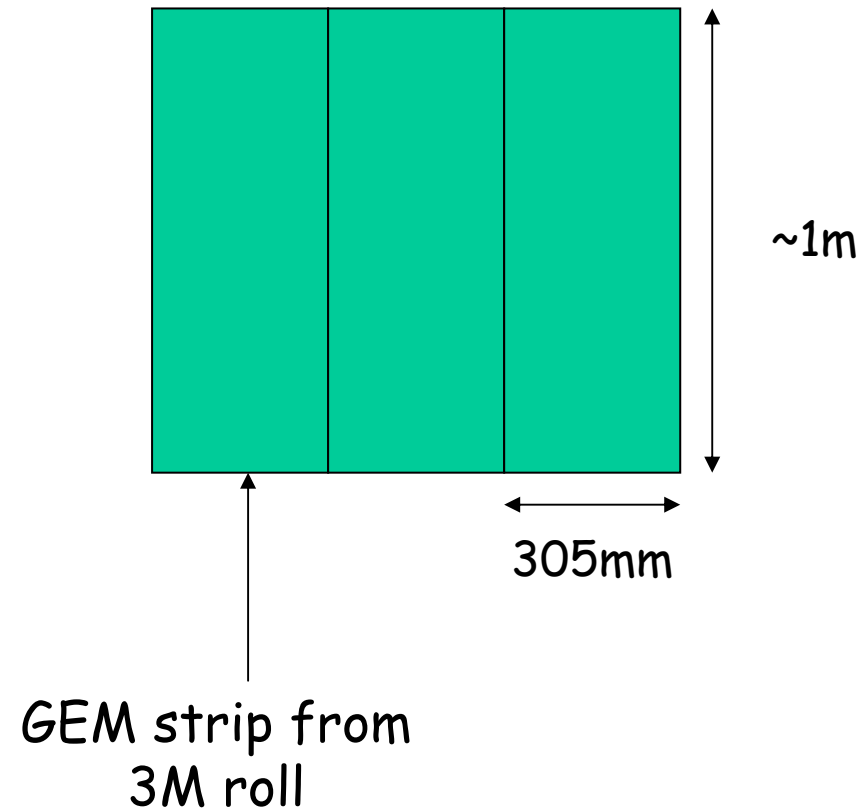

GEM foils for test beam module

- Ongoing discussions with 3M Corporation: research into process modification for "long" foil production:

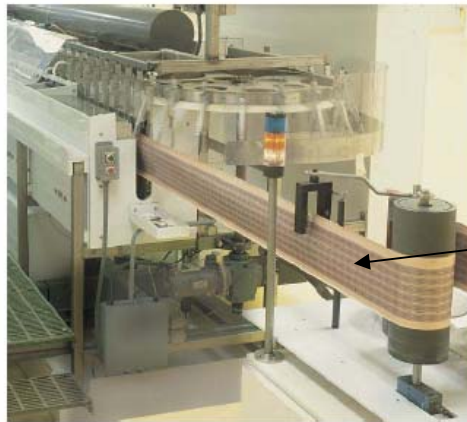

500 ft reel

- Repeat 3 x $\sim 30\text{cm} \times 30\text{cm}$ frame
- Small gaps \rightarrow locate spacers
- 240 long foils needed for test beam module
- Foil production second half of 2005

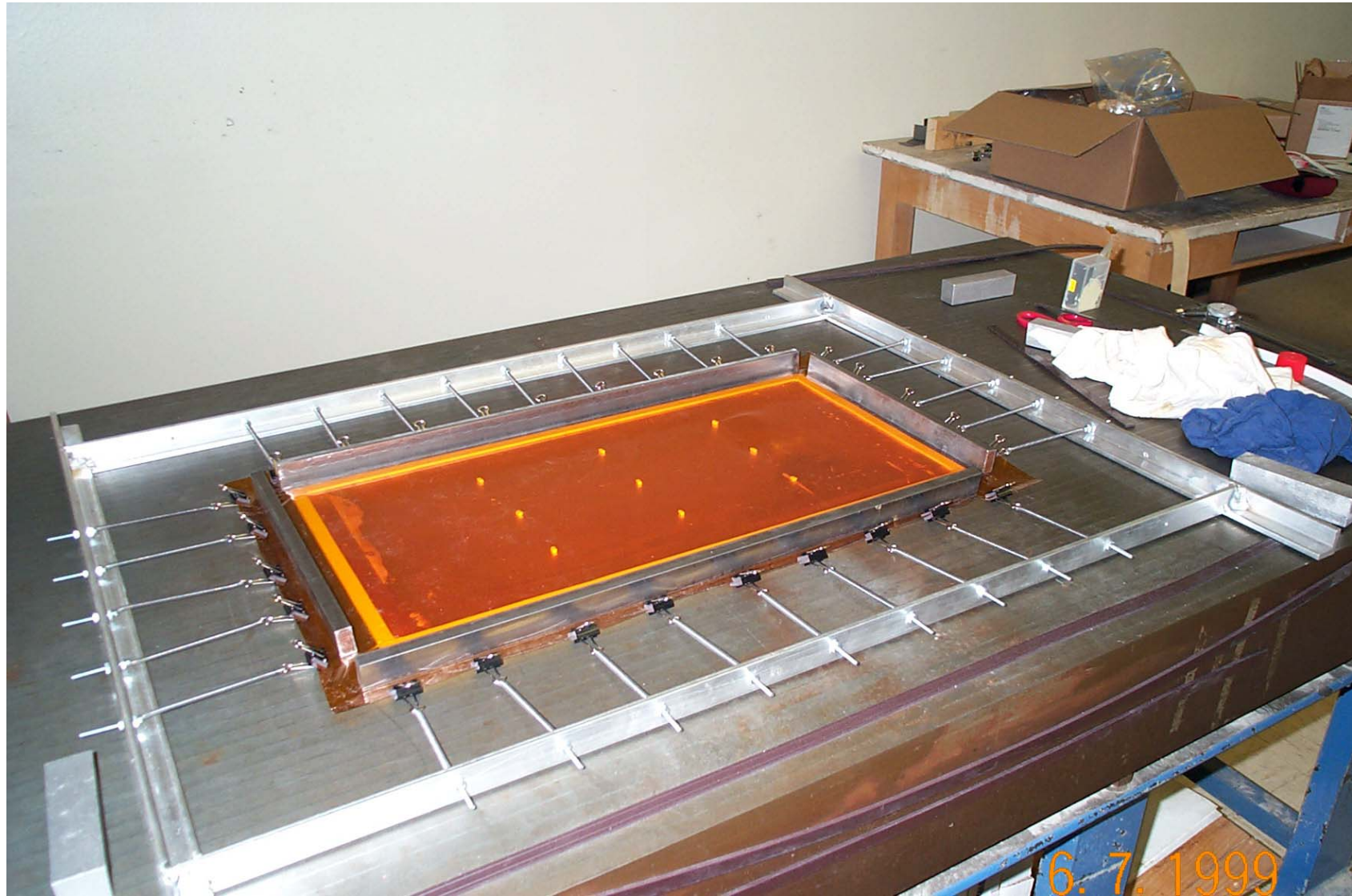

"GEM" foil laid down over side walls and sides weighted



1mm side walls installed plus
spacers and gas in/outlets

Readout/ASIC development (UTA)

- Specification of GEM signals (already discussed)
- Increased signal sizes from changes in gas mixture
- HSPICE simulation:
 - > Software set up at UTA
 - > A LOT of bureaucracy to get a MOSIS commercial license !
 - > Files set up
 - > Working with UTA/EE faculty/grad. Student
- first results 1-2 weeks
- do not expect any surprises - confirm response to GEM signals

GEM detailed simulation

- Garfield/Maxwell simulation of DGEM structure

- Study:

 - Signal size/variation

 - Time structure of GEM charge pulse -> HSPICE

 - Signal spatial distribution (for TB comparison)

 - Effect(s) of $E \perp B$ on electron trajectories

- Two UTA undergraduates working on simulation

Maxwell/Garfield simulations of GEM detector

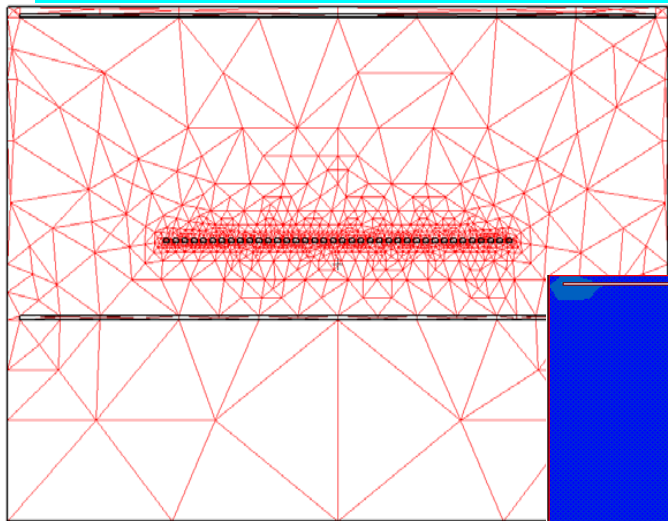

Maxwell

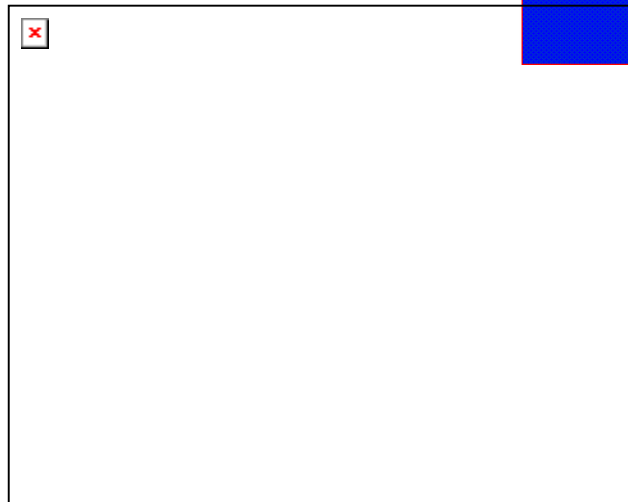
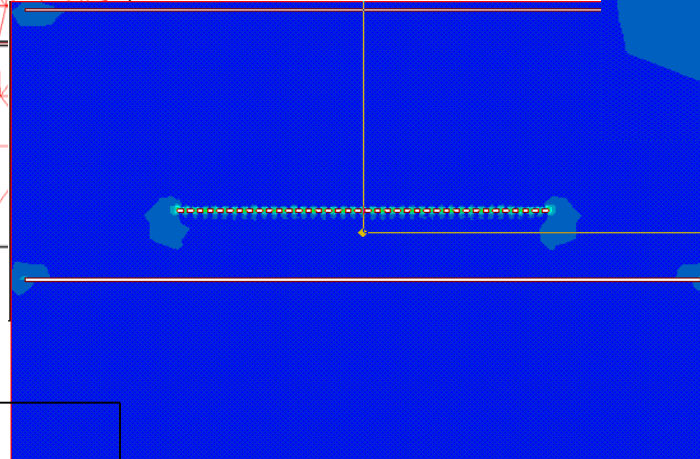
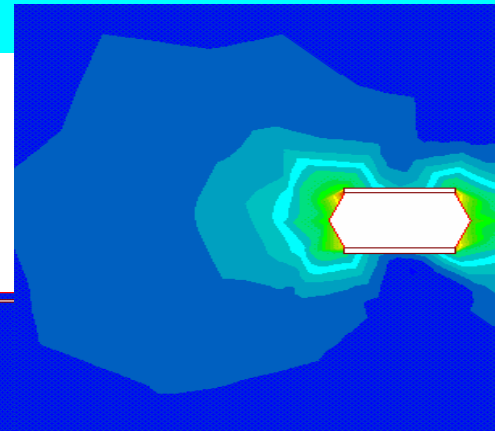

Next: Garfield

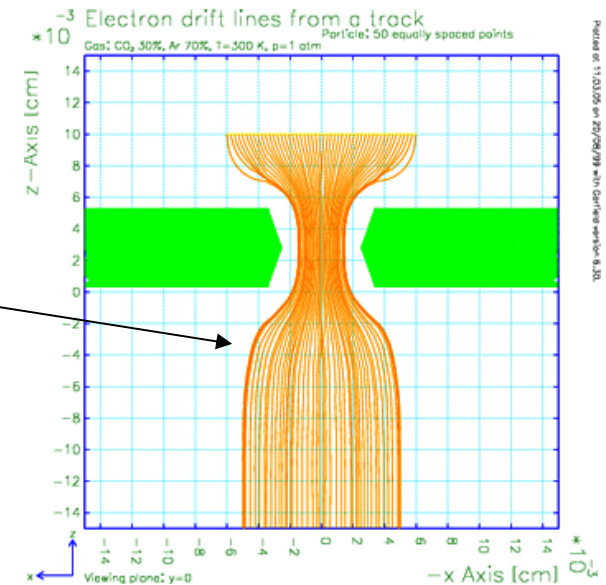

Printed at: 11:23:05 on 20/09/99 with Garfield version 8.31A

Particle/module simulation

Talk by Jae Yu in Simulation and Reconstruction

- Initial single particle and PFA studies concluded by two (now graduated!) MS students.
- Further PFA work planned for Spring 2005 with new students.
- UTA part of US/global(?) effort to produce full-scale PFAs .
- Preparation for comparisons with test beam data.
- **Discussions with UT Dallas** on joining simulation work (shower library work already started) - may also have students help with test beam module assembly.
- Also plans to work on benchmark physics processes relevant to calorimeter performance studies.

DHCAL/GEM plans

- Spring 2005

 - Stack of DGEM chambers - cosmic studies

 - Long foil development with 3M Corp.

- Summer/Fall 2005:

 - Initial long foil production and testing

- Winter 2005/6

 - Production of long foils for test beam module

 - Assembly of 40 DHCAL/GEM $\sim 1\text{m}^2$ active layers

- 2006

 - Full DHCAL/GEM module ready for beam tests.

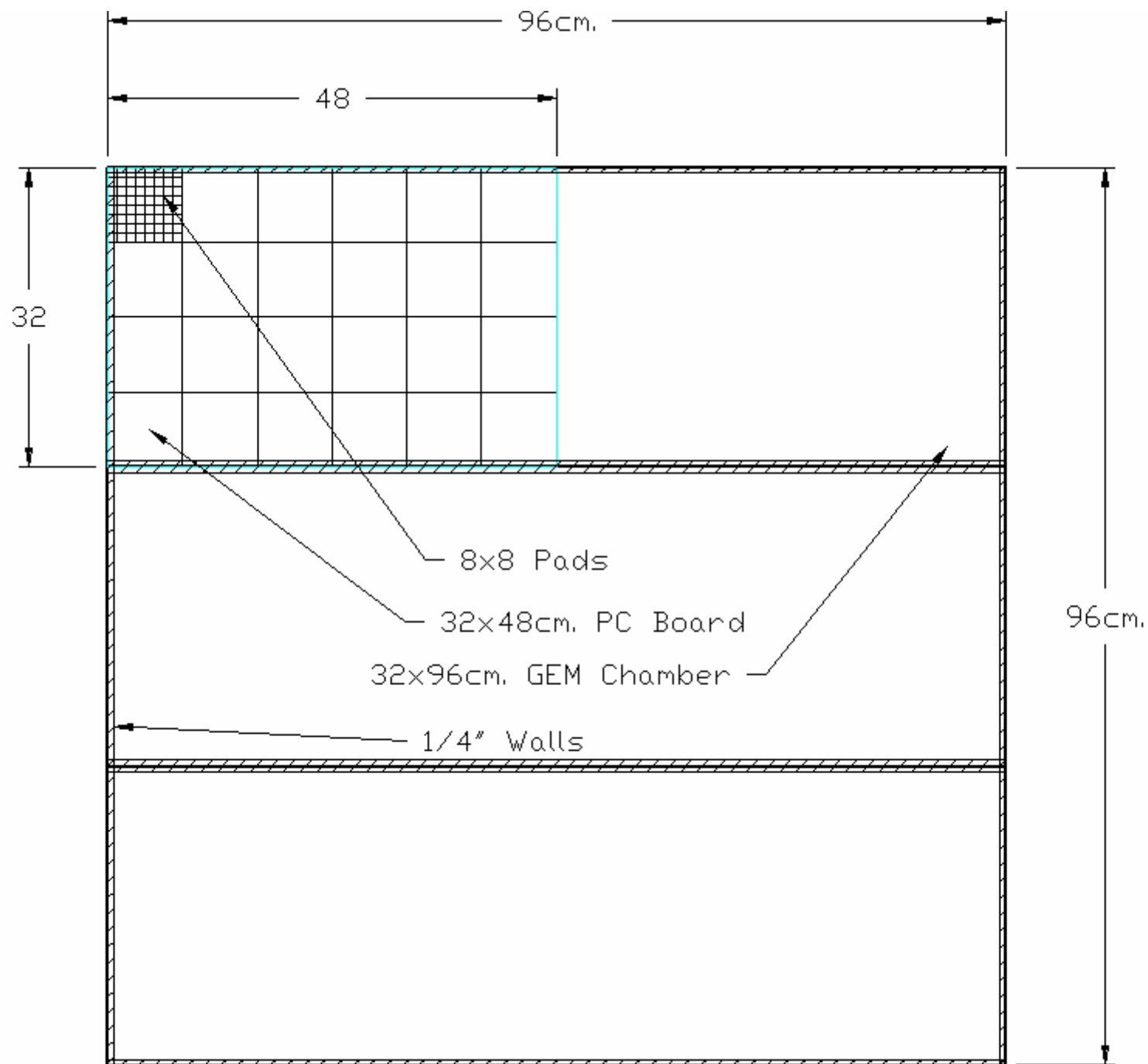

3M GEM foil - new layout

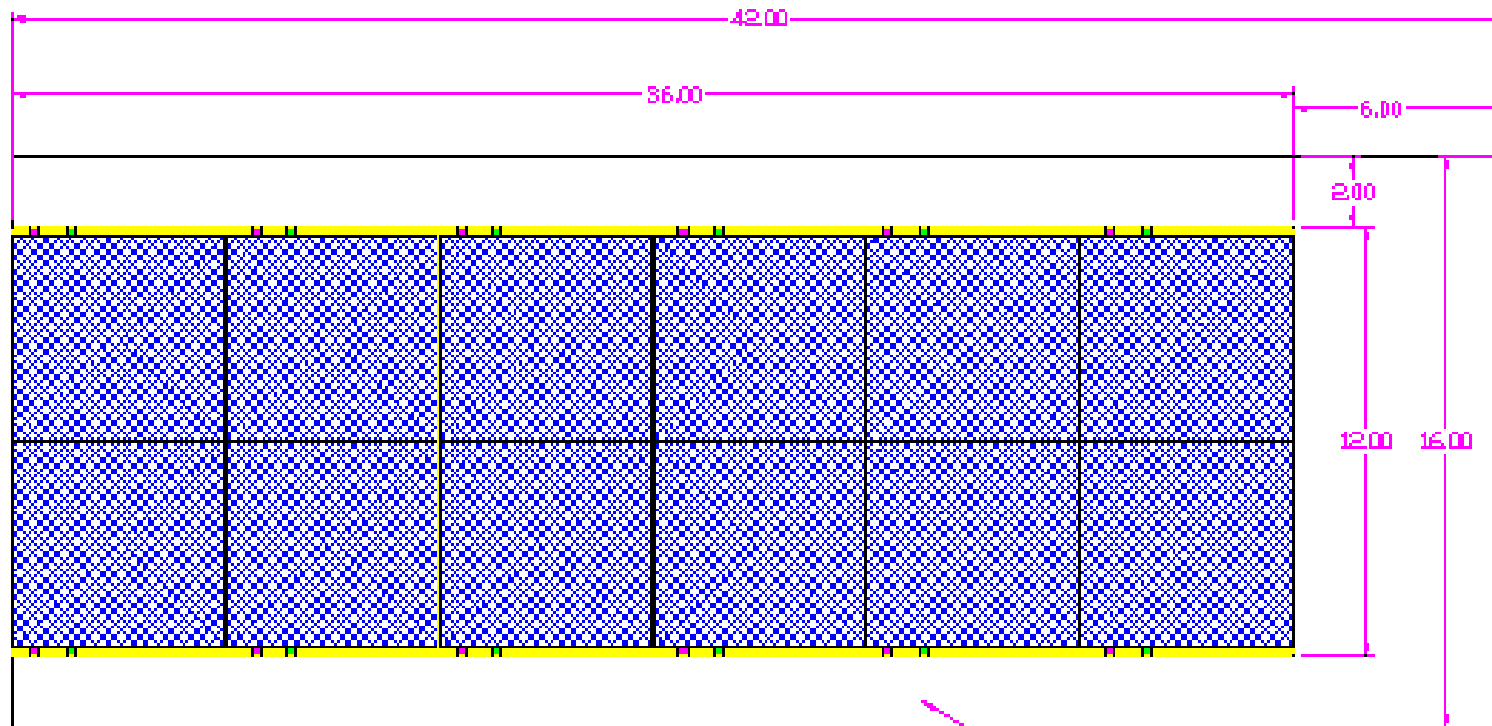

The raw material