

LATTICE

DESIGN II

Lecture 3
January 2017

P.J. Bryant

Colliders

- ❖ In 1943, Rolf Widerøe patented the idea of circular colliders. The diagram is from his patent:

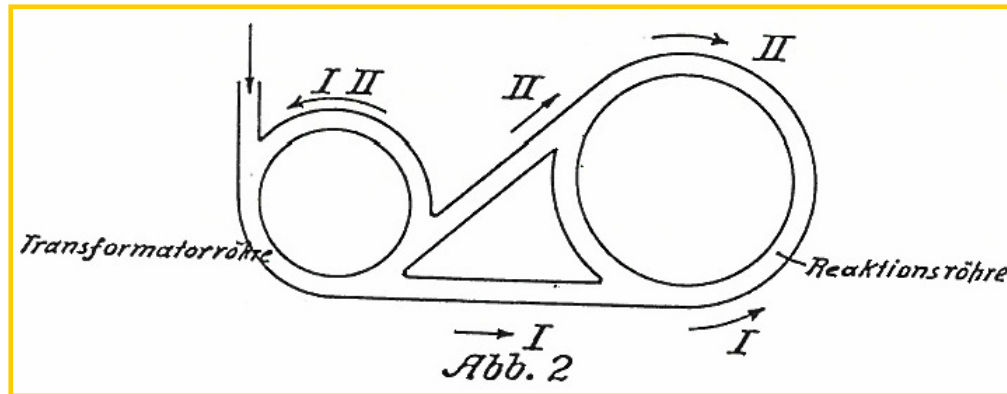

- ❖ The 'centre of mass' energy available in a collision between 2 particles moving on the same line is,

$$E_{\text{cm}} = c^2 \sqrt{2m_{01}m_{02} + 2m_{01}m_{02}\gamma_1\gamma_2(1 - \beta_1\beta_2)}$$

- ❖ For two equal relativistic particles where one is stationary $\beta_2=0$, $\gamma_2=1$.

$$E_{\text{cm}} = \sqrt{2}c^2m_0\sqrt{1 + \gamma} \approx m_0c^2\sqrt{2\gamma} \quad (3.1)$$

- ❖ For two equal relativistic particles in a head-on collision, β_2 changes sign,

$$E_{\text{cm}} = c^2m_0\sqrt{2 + 2\gamma^2(1 + \beta^2)} \approx m_0c^2 2\gamma \quad (3.2)$$

- ❖ **The energy available in a head-on collision far outstrips the energy from a beam hitting a stationary target. This revolutionised HEP.**

Particle-antiparticle colliders

- ❖ AdA was the first single-ring, particle-antiparticle collider ($e^+ e^-$). Built in Frascati, Italy 1961 and first operated in Orsay, France.

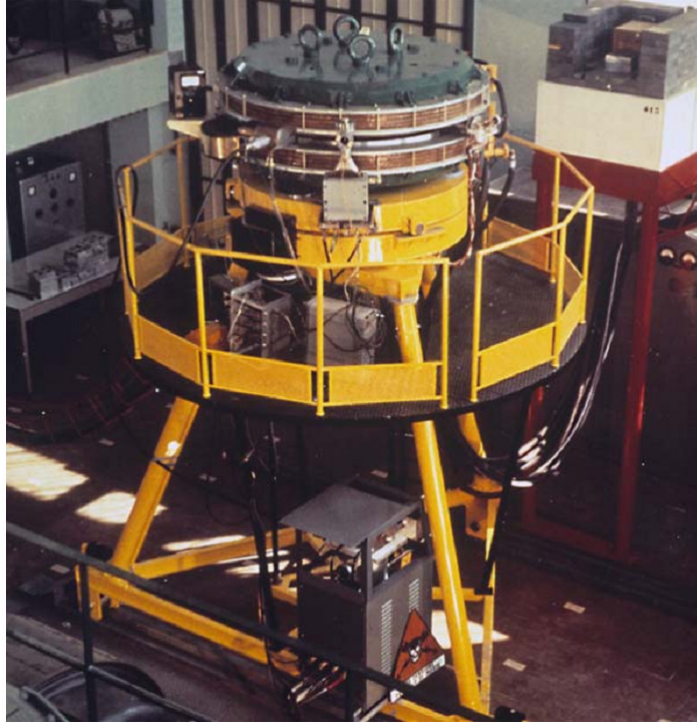

- ❖ It is often said that the $e^+ e^-$ beams follow the same trajectory (with time reversed). In reality, the beams are mostly separated and, if the synchrotron radiation loss is large, the effect can be significant in dispersive regions. **This effect is known as the ‘sawtooth’.**

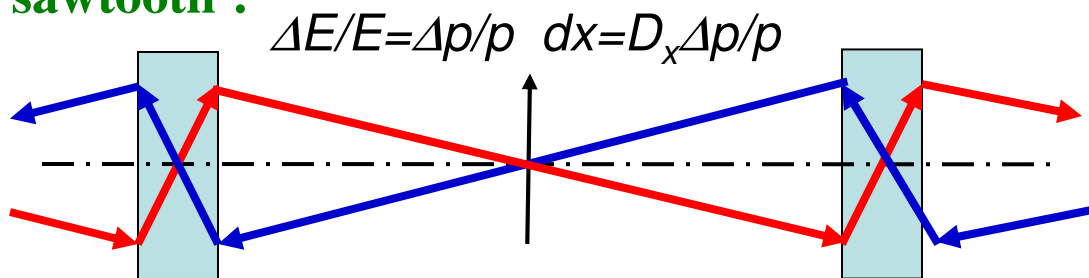

Particle-particle colliders

- ❖ Particle-particle colliders must have two rings. The greater complication and expense delayed their development.
- ❖ In 1971 CERN commissioned the ISR, the first proton-proton, intersecting-ring collider.

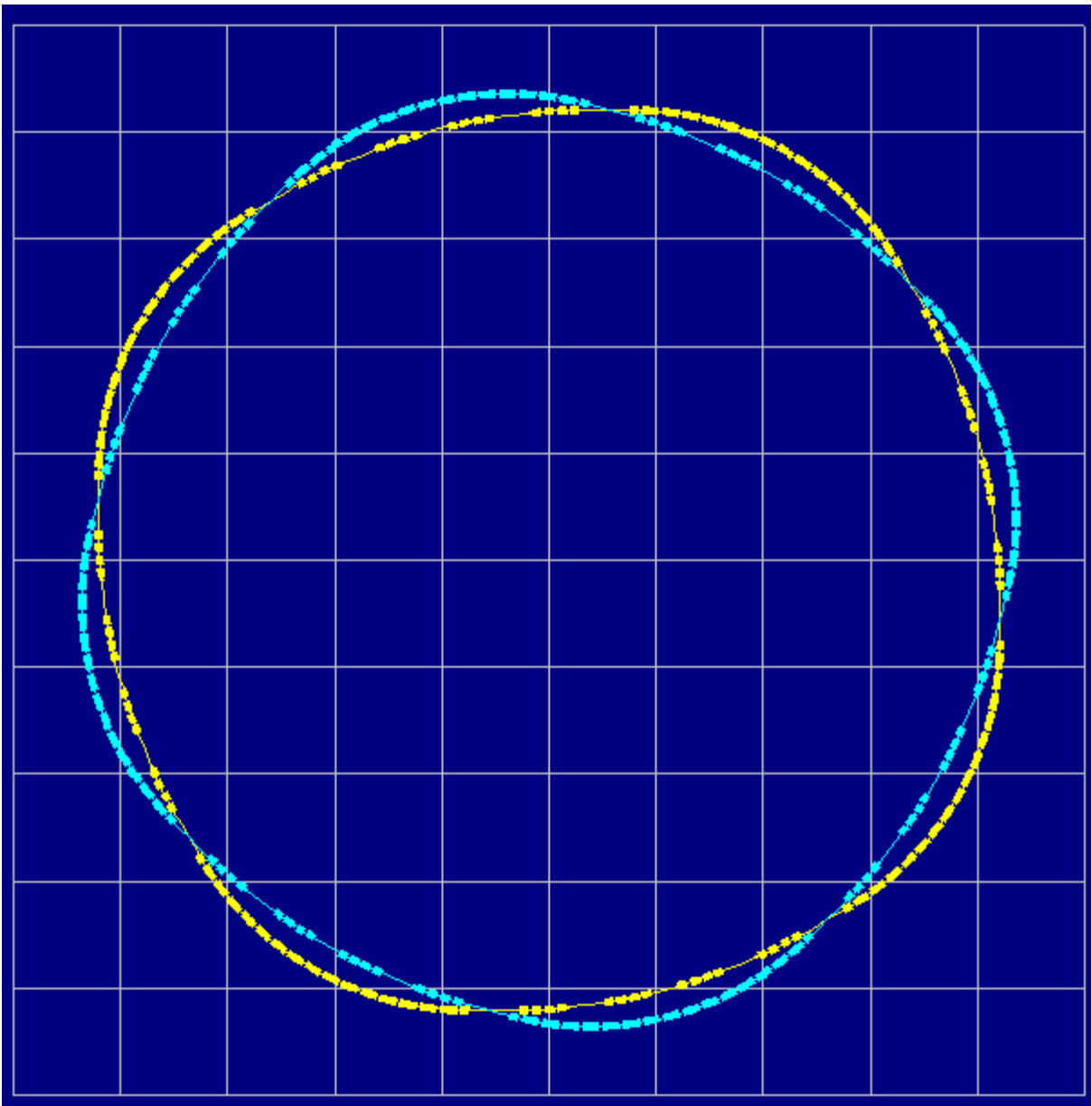

Twin-bore magnets

- ❖ In 1971, John Blewett proposed the twin-bore superconducting magnet as a cost-saving design for superconducting, proton-proton colliders. The two apertures share 40% of the same flux and only one cryostat is needed Ref [3.1].
- ❖ The drawbacks are that asymmetric beam energies and proton-antiproton beams are excluded.

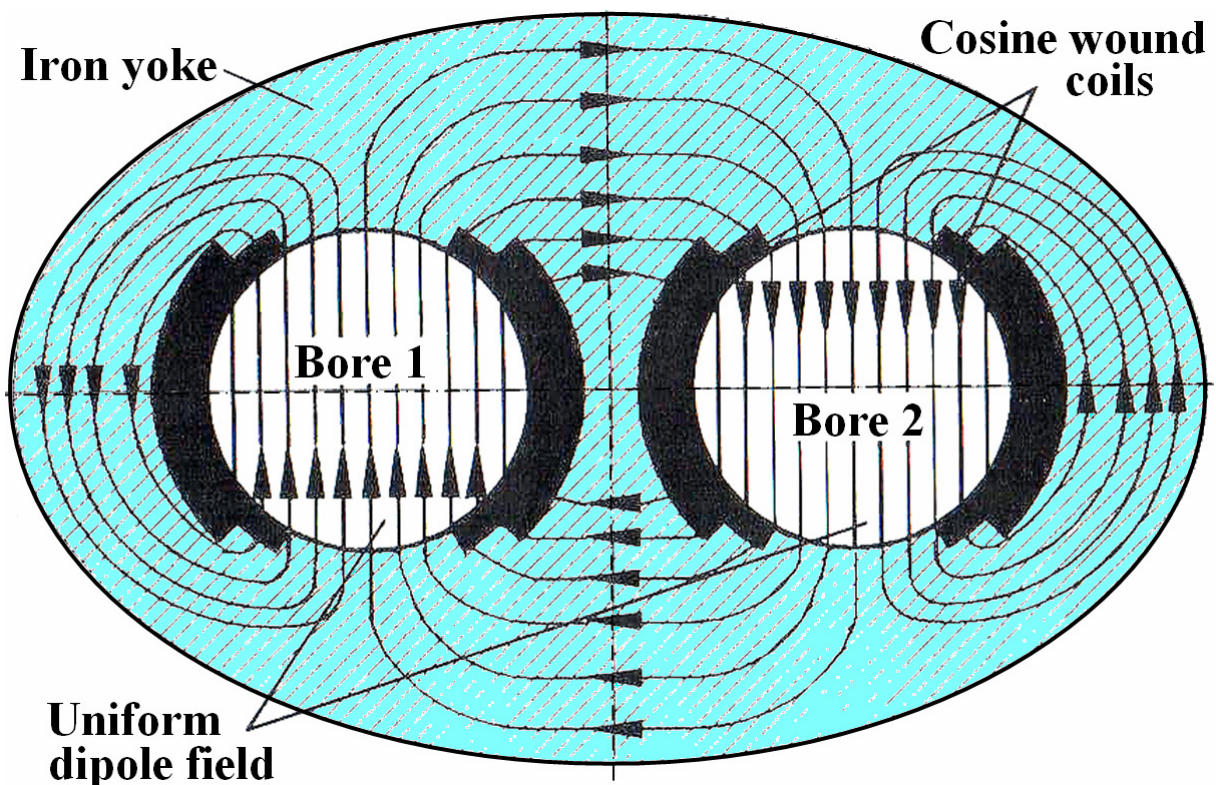

- ❖ The twin-bore design is used in the LHC. This choice was driven mainly by the lack of space in the already existing LEP tunnel.

Luminosity

- ❖ The performance of a collider is measured by its luminosity, L , defined as :

the event rate of an interaction at a beam crossing normalized by the cross-section of that interaction [number of events $\text{cm}^{-2} \text{s}^{-1}$].

e.g. a luminosity of $10^{30} \text{ cm}^{-2} \text{ s}^{-1}$ produces 1 event s^{-1} for an interaction with a cross-section of 10^{-30} cm^2 .

- ❖ The luminosity depends on the geometry of the interaction region and the beam characteristics. Approximating for relativistic beams :

- ❖ **Small angle crossing,**

$$L \approx \frac{I_1 I_2}{ce^2 h_{\text{eff}} (\alpha/2)} \text{ or } \frac{N_1 N_2 f_{\text{rev}}^2}{ch_{\text{eff}} \tan(\alpha/2)} \quad \text{where } h_{\text{eff}} \approx 2\sqrt{\pi}\sigma_z \quad (3.3)$$

- ❖ **Head-on crossing,**

$$L \approx \frac{I_1 I_2}{e^2 S_{\text{eff}} f_{\text{bunch}}} \text{ or } \frac{N_1 N_2 f_{\text{bunch}}}{S_{\text{eff}}} \quad \text{where } S_{\text{eff}} \approx 2\pi(\sigma_x^2 + \sigma_z^2) \quad (3.4)$$

- ❖ **Effect of bunching,**

Bunching factor, Λ = Average /Peak current.

Increase in instantaneous luminosity of $1/\Lambda^2$.

Decrease in luminosity due to less active time of Λ .

Overall effect on above Λ^{-1} .

Non-linear optics

- ❖ **Some applications require a uniform density beam spread over a large area for irradiation purposes.**
- ❖ **Cancer therapy uses scattering (so-called passive spreading). The APT – Accelerator for Production of Tritium design used optical spreading.**
- ❖ **A purely optical system is cleaner, more efficient and applicable to complex ions and fissile nuclei.**
- ❖ **Simply increasing the betatron amplitudes leads to Gaussian-type distributions.**
- ❖ **The secret is to use nonlinear optics that sequentially fold the vertical and horizontal tails of the nearly Gaussian beam profiles back onto the core to achieve a nearly rectangular uniform beam.**

Nonlinear optics continued

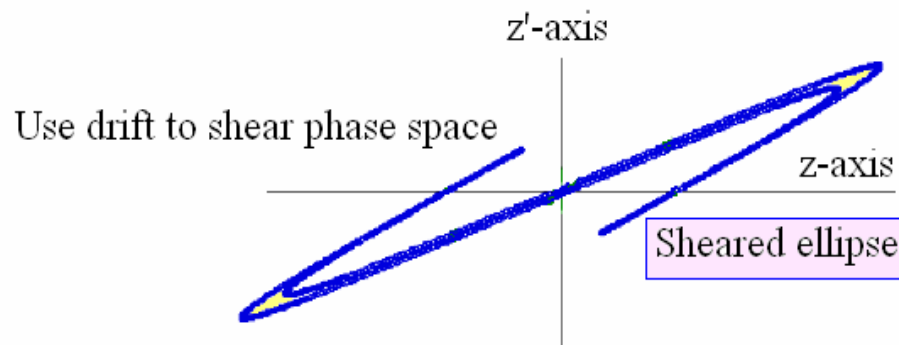
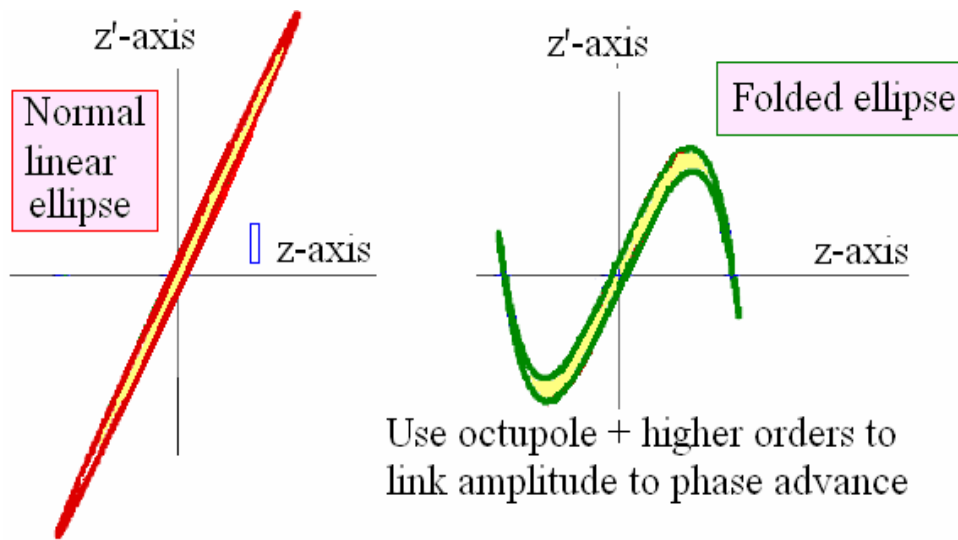
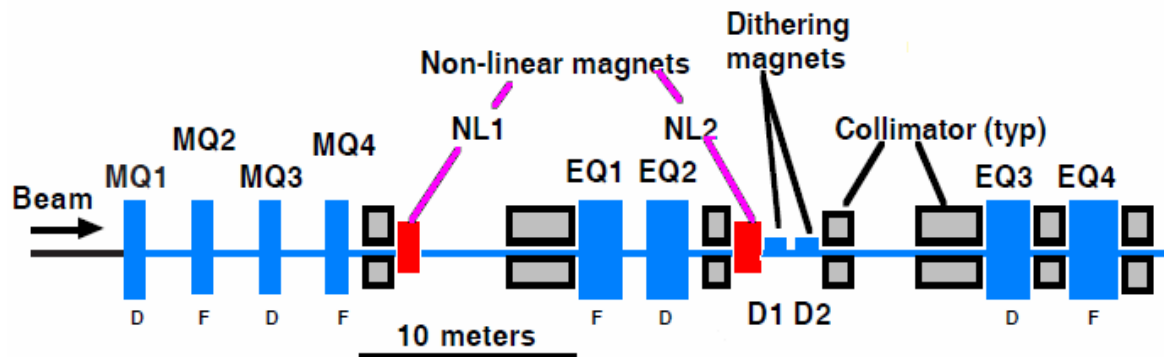

Based on Ref. [3.2].

Möbius



$$\begin{pmatrix} 0 & \pm I \\ I & 0 \end{pmatrix}_{\text{TWIST}}$$

- ❖ The Möbius accelerator has been built and it worked (CESR, USA 1990s Ref. [3.3]).
- ❖ Two solutions for how to twist the horizontal plane into the vertical and the vertical into the horizontal will be explained in the following slides.
- ❖ With just one twist in the circumference, two turns are needed to get back to the initial conditions.
- ❖ There is 1 tune and 1 chromaticity, but the full machine comprises 2 turns.
- ❖ This simplifies the resonance pattern and halves the number of conditions to be met for the head-tail instability, for example, but complicates orbit correction.
- ❖ Coasting beams become round due to debunching. Bunched beams with asymmetric emittances alternate their aspect ratio from turn to turn.

Emittance inverter

- ❖ An emittance inverter interchanges the horizontal and vertical planes .
- ❖ This could be the module for a Möbius accelerator, but often there is simply a preference to invert the emittances for aperture or luminosity reasons.
- ❖ The basic requirement is an insertion with the transfer matrix,

$$T_{\text{Insertion}} = \begin{pmatrix} 0 & 0 & m_{13} & m_{14} \\ 0 & 0 & m_{23} & m_{24} \\ m_{31} & m_{32} & 0 & 0 \\ m_{41} & m_{42} & 0 & 0 \end{pmatrix} \quad (3.5)$$

- ❖ There are many possible solutions, but the following is quite elegant (based on Ref. [3.4]).
- ❖ First construct a thin-lens skew quadrupole

$$\underbrace{\begin{pmatrix} \cos \frac{\pi}{4} & 0 & -\sin \frac{\pi}{4} & 0 \\ 0 & \cos \frac{\pi}{4} & 0 & -\sin \frac{\pi}{4} \\ \sin \frac{\pi}{4} & 0 & \cos \frac{\pi}{4} & 0 \\ 0 & \sin \frac{\pi}{4} & 0 & \cos \frac{\pi}{4} \end{pmatrix}}_{\text{Rotation } -\pi/4} \underbrace{\begin{pmatrix} 1 & 0 & 0 & 0 \\ \delta_s & 1 & 0 & 0 \\ 0 & 0 & 1 & 0 \\ 0 & 0 & -\delta_s & 1 \end{pmatrix}}_{\text{Thin quad}} \underbrace{\begin{pmatrix} \cos \frac{\pi}{4} & 0 & \sin \frac{\pi}{4} & 0 \\ 0 & \cos \frac{\pi}{4} & 0 & \sin \frac{\pi}{4} \\ -\sin \frac{\pi}{4} & 0 & \cos \frac{\pi}{4} & 0 \\ 0 & -\sin \frac{\pi}{4} & 0 & \cos \frac{\pi}{4} \end{pmatrix}}_{\text{Rotation } \pi/4}$$

where

$$\delta_s = \frac{\ell}{B\rho} \frac{dB_z}{ds} \quad (3.6)$$

Emittance inverter continued

- ❖ Multiplying out gives the thin skew quad. matrix

$$\delta_s = \begin{pmatrix} 1 & 0 & 0 & 0 \\ 0 & 1 & \delta_s & 0 \\ 0 & 0 & 1 & 0 \\ \delta_s & 0 & 0 & 1 \end{pmatrix} \quad (3.7)$$

- ❖ Now consider 2 FODO cells with 3 thin skew quads,

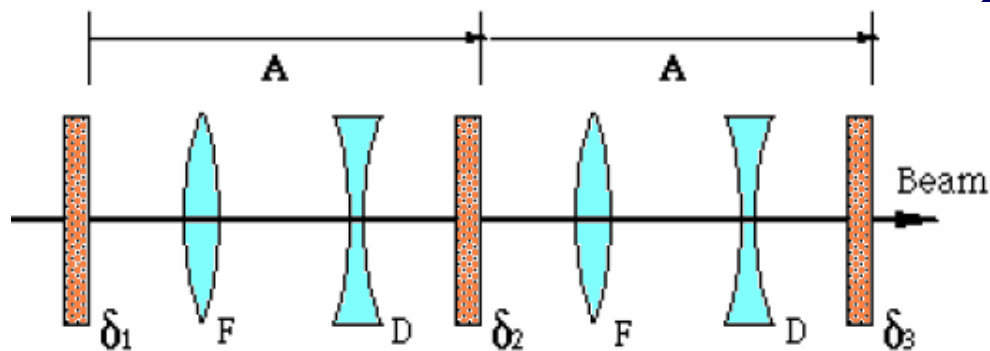

where A is the transfer matrix of the FODO cell without the skew lenses. Let matrix A have the phase advance μ_0 in both planes and express the matrix at the mid-point between F and D (α_m, β_m).

$$A = \begin{pmatrix} (\cos \mu_0 \pm \alpha_m \sin \mu_0) & \beta_m \sin \mu_0 \\ -\gamma_m \sin \mu_0 & (\cos \mu_0 \mp \alpha_m \sin \mu_0) \end{pmatrix}$$

- ❖ Now choose $\mu_0 = \pi/2$, so that

$$\begin{pmatrix} \alpha_m & \beta_m & 0 & 0 \\ -\gamma_m & -\alpha_m & 0 & 0 \\ 0 & 0 & -\alpha_m & \beta_m \\ 0 & 0 & -\gamma_m & \alpha_m \end{pmatrix} \quad (3.8)$$

Emittance inverter continued

- ❖ The insertion can now be evaluated as,

$$T_{\text{Insertion}} = \delta_3 A \delta_2 A \delta_1 \quad (3.9)$$

$$\left(\begin{array}{cccc} (\beta^2 \delta_1 \delta_2 - 1) & 0 & -\alpha \beta \delta_2 & \beta^2 \delta_2 \\ \alpha \beta (\delta_2 \delta_3 - \delta_1 \delta_2) & (\beta^2 \delta_2 \delta_3 - 1) & (-\delta_1 + \beta^2 \delta_1 \delta_2 \delta_3 + \alpha^2 \delta_2 - \delta_3) & -\alpha \beta \delta_2 \\ \alpha \beta \delta_2 & \beta^2 \delta_2 & (\beta^2 \delta_1 \delta_2 - 1) & 0 \\ (-\delta_1 + \beta^2 \delta_1 \delta_2 \delta_3 + \alpha^2 \delta_2 - \delta_3) & \alpha \beta \delta_2 & \alpha \beta (\delta_1 \delta_2 - \delta_2 \delta_3) & (\beta^2 \delta_2 \delta_3 - 1) \end{array} \right)$$

- ❖ To satisfy the required form of (3.5), there are three conditions,

$$\beta_m^2 \delta_1 \delta_2 - 1 = 0; \quad \beta_m^2 \delta_2 \delta_3 - 1 = 0; \quad (\delta_2 \delta_3 - \delta_1 \delta_2) = 0$$

- ❖ These are satisfied if

$$\delta_1 = \delta_2 = \delta_3 = \delta_s \quad \text{and} \quad \beta_m = \frac{1}{\delta_s} \quad (3.10a)$$

- ❖ or

$$\delta_1 = \delta_3 = \delta_s \quad \text{and} \quad \beta_m^2 = \frac{1}{\delta_s \delta_2} \quad (3.10b)$$

In practice, putting the 3 skew quadrupoles in series would be the more attractive solution. Either sign is possible.

Emittance inverter continued

- ❖ **Substituting (3.10a) into (3.9) gives**

$$\begin{pmatrix} 0 & 0 & -\alpha_m & \beta_m \\ 0 & 0 & \left(-\frac{2}{\beta_m} + \gamma_m\right) & -\alpha_m \\ \alpha_m & \beta_m & 0 & 0 \\ \left(-\frac{2}{\beta_m} + \gamma_m\right) & \alpha_m & 0 & 0 \end{pmatrix} \quad (3.11)$$

- ❖ **With the 3 skew quadrupoles turned off, the transfer matrix would have been**

$$\begin{pmatrix} -1 & 0 & 0 & 0 \\ 0 & -1 & 0 & 0 \\ 0 & 0 & -1 & 0 \\ 0 & 0 & 0 & -1 \end{pmatrix} \quad (3.12)$$

- ❖ **Thus equation (3.11) shows the crossover between the planes with a phase advance with respect to the double FODO cell.**

A quick check shows the modulus is still unity.

Emittance inverter continued

❖ Beam widths in basic FODO.

1π [mm mrad] horizontal emittance (upper curve)
 4π [mm mrad] vertical emittance (lower curve).

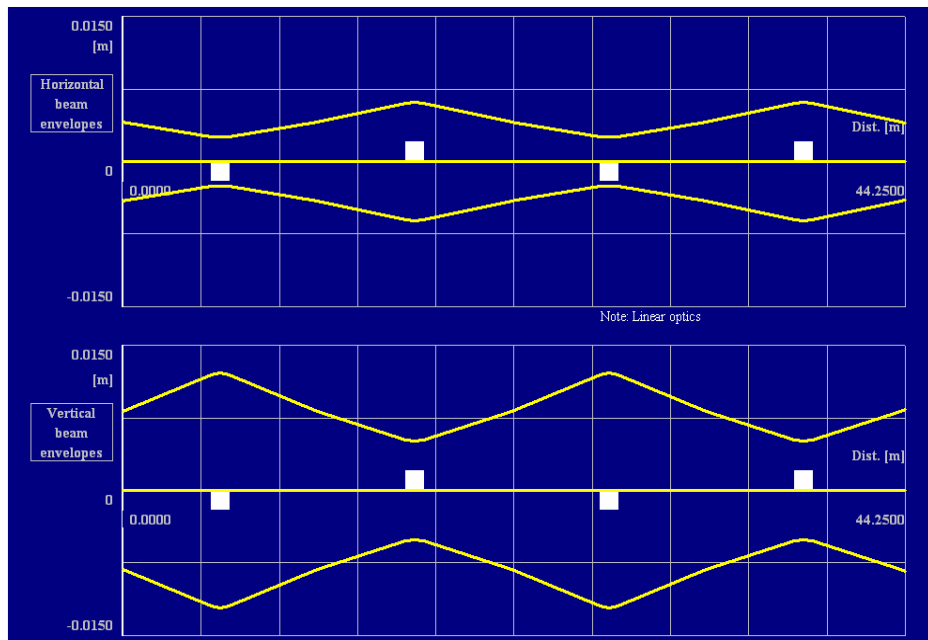

❖ Inverter with skew quads powered.

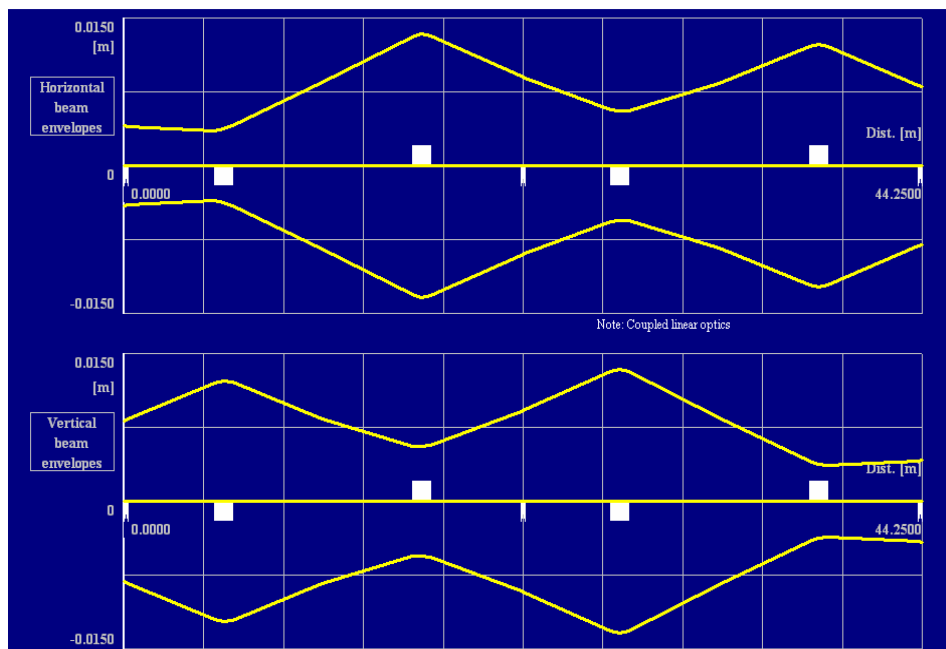

Medical gantry

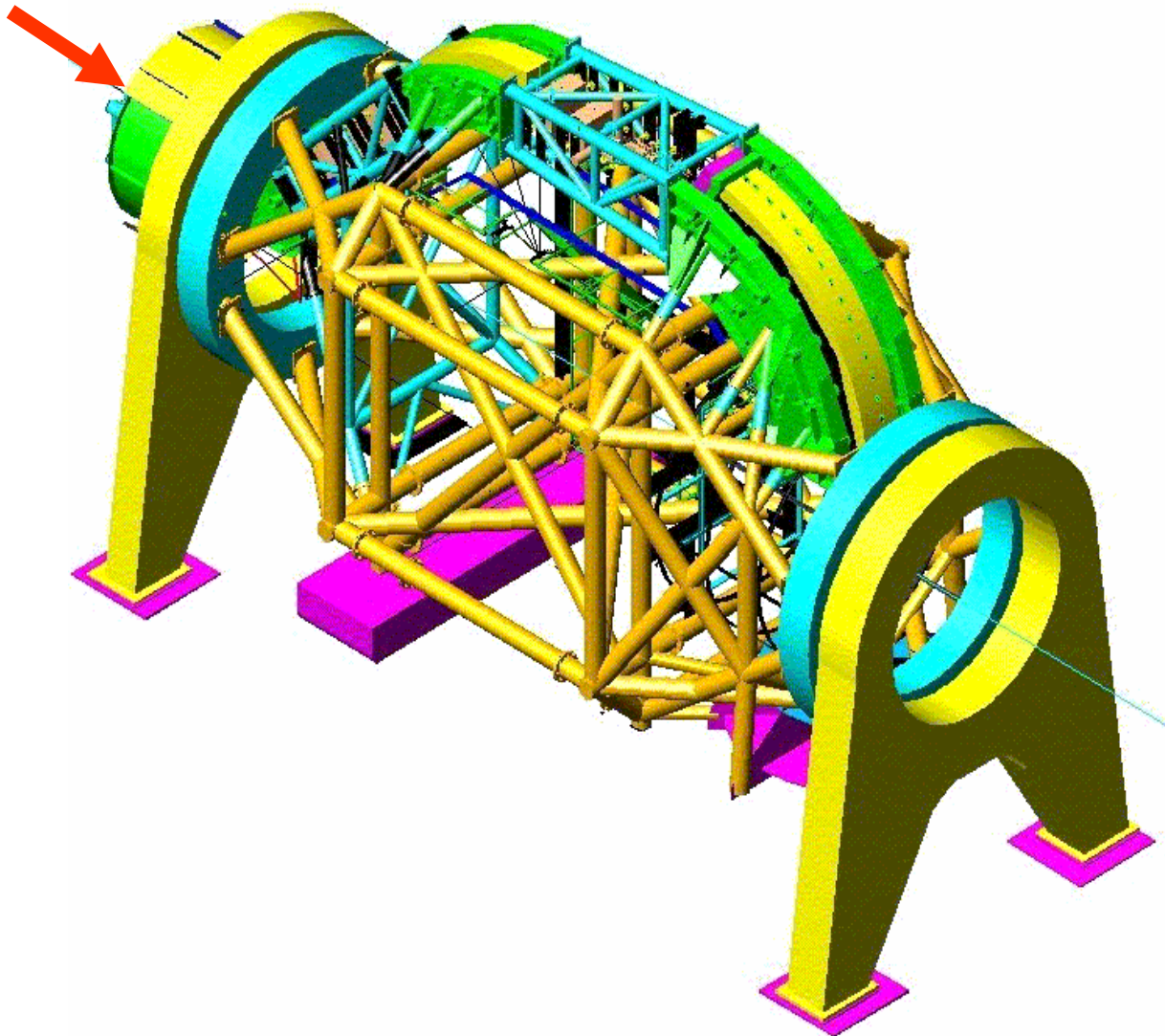

- ❖ **GSI iso-centric gantry.**
- ❖ **Rotates 360° around patient.**
- ❖ **13 m diameter.**
- ❖ **25 m length.**
- ❖ **600 t overall weight.**

Rotational optics

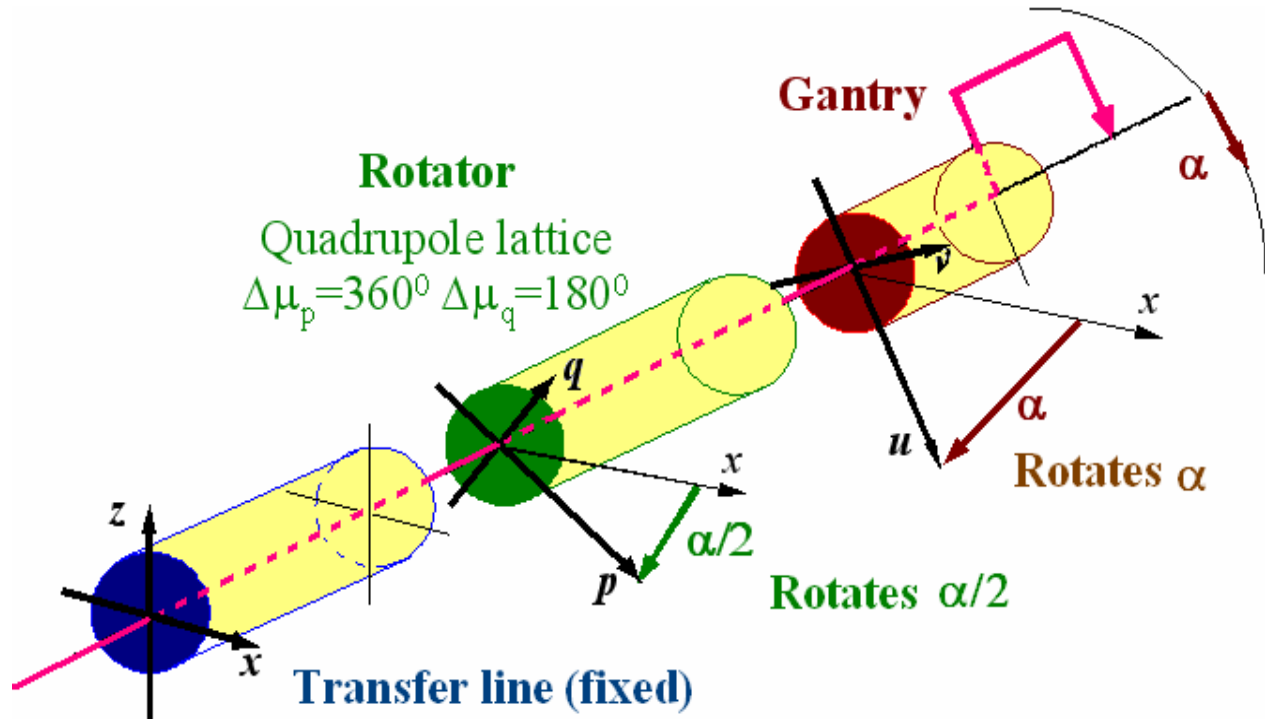

- ❖ A *rotator module* (1:1 horizontal, 1:-1 vertical) is mounted between the fixed beam line and the gantry.
- ❖ The rotator is turned by $\alpha/2 =$ half the angle turned by the gantry.
- ❖ The Twiss and dispersion functions are transferred exactly to the rotated coordinate system of the gantry.

Attributed to L. Teng Reference [3.5].

Rotational optics continued

$M =$

$$\underbrace{\begin{pmatrix} \cos \frac{\alpha}{2} & 0 & \sin \frac{\alpha}{2} & 0 \\ 0 & \cos \frac{\alpha}{2} & 0 & \sin \frac{\alpha}{2} \\ -\sin \frac{\alpha}{2} & 0 & \cos \frac{\alpha}{2} & 0 \\ 0 & -\sin \frac{\alpha}{2} & 0 & \cos \frac{\alpha}{2} \end{pmatrix}}_{\text{Rotation from Rotator to Gantry}} \underbrace{\begin{pmatrix} 1 & 0 & 0 & 0 \\ 0 & 1 & 0 & 0 \\ 0 & 0 & -1 & 0 \\ 0 & 0 & 0 & -1 \end{pmatrix}}_{\text{Rotator}} \underbrace{\begin{pmatrix} \cos \frac{\alpha}{2} & 0 & \sin \frac{\alpha}{2} & 0 \\ 0 & \cos \frac{\alpha}{2} & 0 & \sin \frac{\alpha}{2} \\ -\sin \frac{\alpha}{2} & 0 & \cos \frac{\alpha}{2} & 0 \\ 0 & -\sin \frac{\alpha}{2} & 0 & \cos \frac{\alpha}{2} \end{pmatrix}}_{\text{Rotation from Line to Rotator}}$$

$$= \begin{pmatrix} \cos^2 \frac{\alpha}{2} + \sin^2 \frac{\alpha}{2} & 0 & \sin \frac{\alpha}{2} \cos \frac{\alpha}{2} - \cos \frac{\alpha}{2} \sin \frac{\alpha}{2} & 0 \\ 0 & \cos^2 \frac{\alpha}{2} + \sin^2 \frac{\alpha}{2} & 0 & \sin \frac{\alpha}{2} \cos \frac{\alpha}{2} - \cos \frac{\alpha}{2} \sin \frac{\alpha}{2} \\ -\sin \frac{\alpha}{2} \cos \frac{\alpha}{2} + \cos \frac{\alpha}{2} \sin \frac{\alpha}{2} & 0 & -\cos^2 \frac{\alpha}{2} - \sin^2 \frac{\alpha}{2} & 0 \\ 0 & -\sin \frac{\alpha}{2} \cos \frac{\alpha}{2} + \cos \frac{\alpha}{2} \sin \frac{\alpha}{2} & 0 & -\cos^2 \frac{\alpha}{2} - \sin^2 \frac{\alpha}{2} \end{pmatrix}$$

$$\begin{pmatrix} u \\ u' \\ v \\ v' \end{pmatrix}_{\text{Gantry}} = \underbrace{\begin{pmatrix} 1 & 0 & 0 & 0 \\ 0 & 1 & 0 & 0 \\ 0 & 0 & -1 & 0 \\ 0 & 0 & 0 & -1 \end{pmatrix}}_{\text{Angle independent}} \begin{pmatrix} x \\ x' \\ y \\ y' \end{pmatrix}_{\text{Input Line}} \quad (3.13)$$

- ❖ The transfers of (x, x') to (u, u') and (y, y') to (v, v') are mathematically rigorous and exact.
- ❖ The problems are in the engineering and the optical design of the Rotator.

Rotational optics continued

- ❖ A rotator module could be built using FODO cells as described earlier.
- ❖ However, a rotation of $\pi/2$ changes all F-quads into D-quads. When viewed this way, it is not surprising that the FODO rotator leads to large fluctuations of the lattice functions.
- ❖ This effect is strong when the entry values for the alpha functions are large and have opposite signs.
- ❖ **This gives the first hint that rotators are best made with zero alpha functions at entry and exit.**
- ❖ Below is a *doublet-triplet-doublet rotator*, in which the betatron amplitude functions remain well-behaved at all angles.

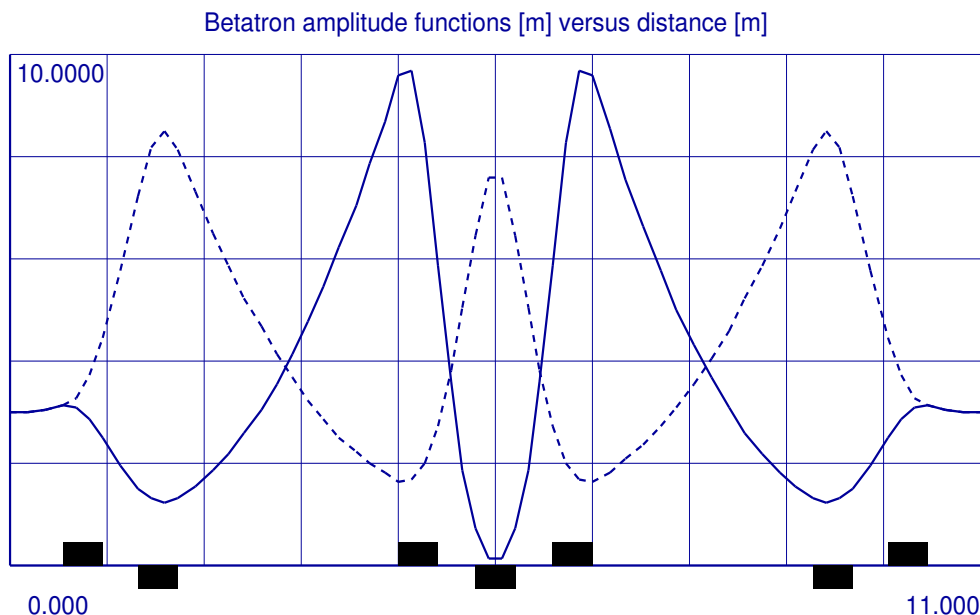

Beam size in a rotated/coupled lattice

- ❖ Other designs include this *triple-triplet rotator*.

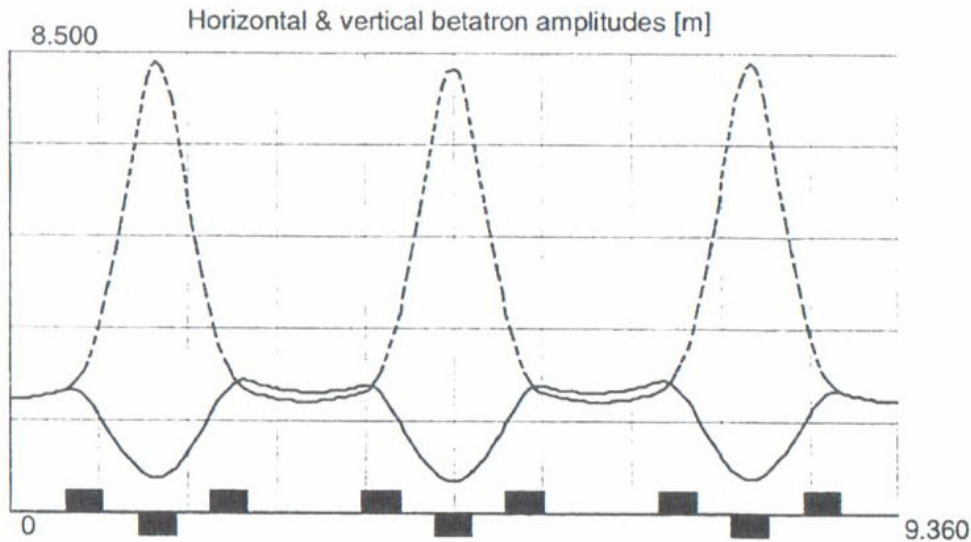

- ❖ The sigma matrices can be used to track the beam sizes through the rotator. Terms m_{11} and m_{33} give the beam width and height on the orthogonal p - q planes (see last lecture).

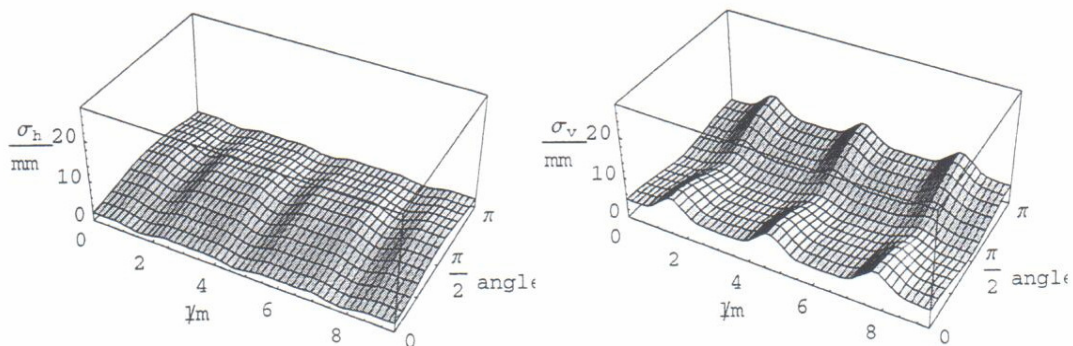

- ❖ When tracking across a rotation plane, there will be a discontinuity in the beam sizes where the plane changes.

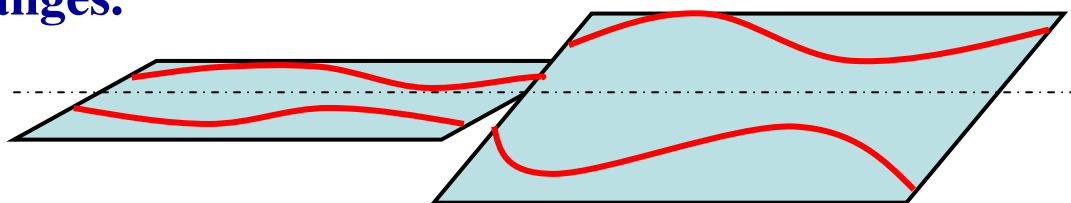

Using the Rotator as an Inverter

- ❖ **Turning the rotator by $\pi/4$ will rotate the normal modes by $\pi/2$ and the horizontal and vertical planes will be interchanged thus creating an inverter.**
- ❖ **Mounting the quadrupoles in a cylindrical cage sitting on rollers would make it possible to switch quickly between inverting and not inverting. This could be useful for setting up the beam in a Möbius ring.**
- ❖ **The skew quadrupole inverter presented earlier can function with the skew quadrupoles off making switching inversion on and off rapid.**
- ❖ **However, the skew quadrupole inverter introduces a phase shift between inversion and non-inversion. Thus there is a preference for the Rotator-Inverter.**

Collins insertion

- ❖ Machines consisting of only regular cells lack space for equipment. The first machine designers simply introduced long drift spaces in symmetric positions and accepted the ‘flutter’ in the Twiss parameters that resulted.
- ❖ **T. Collins proposed a matched insertion for a drift space Ref. [3.6]. This is one of the first examples of the use of thin lenses to construct an optical module.**

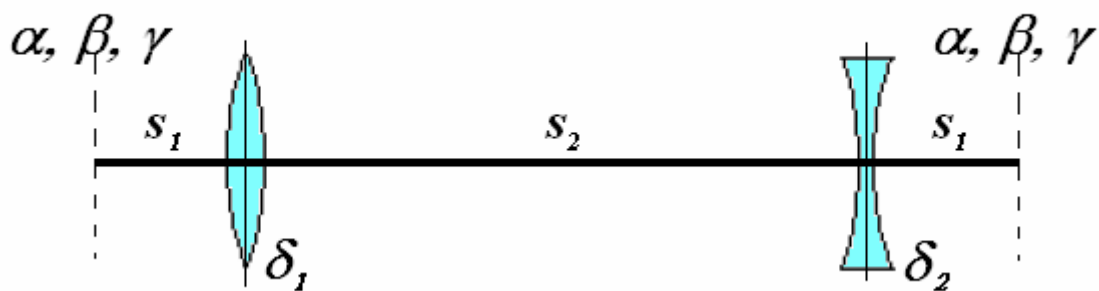

$$\begin{pmatrix} 1 & s_1 \\ 0 & 1 \end{pmatrix} \begin{pmatrix} 1 & 0 \\ \delta_2 & 1 \end{pmatrix} \begin{pmatrix} 1 & s_2 \\ 0 & 1 \end{pmatrix} \begin{pmatrix} 1 & 0 \\ \delta_1 & 1 \end{pmatrix} \begin{pmatrix} 1 & s_1 \\ 0 & 1 \end{pmatrix}$$

where $\delta = -1/f = (-1/B\rho)/(dB_z/dx)$.

Unfortunately the dispersion is not matched so this is better used in a zero-dispersion region.

Collins insertion continued

- ❖ Multiplying out the matrices gives,

$$\begin{pmatrix} 1 + s_2\delta - s_1s_2\delta^2 & 2s_1 + s_2 - s_1^2s_2\delta^2 \\ -s_2\delta^2 & 1 - s_2\delta - s_1s_2\delta^2 \end{pmatrix}$$

- ❖ Now consider the general transfer matrix from Eqn (1.8),

$$\begin{pmatrix} \left(\frac{\beta_2}{\beta_1}\right)^{1/2} (\cos \Delta\mu + \alpha_1 \sin \Delta\mu) & (\beta_1\beta_2)^{1/2} \sin \Delta\mu \\ -(\beta_1\beta_2)^{-1/2} [(1 + \alpha_1\alpha_2) \sin \Delta\mu + (\alpha_2 - \alpha_1) \cos \Delta\mu] & \left(\frac{\beta_1}{\beta_2}\right)^{1/2} (\cos \Delta\mu - \alpha_2 \sin \Delta\mu) \end{pmatrix}$$

and impose the Collins conditions that $\beta_1 = \beta_2 = \beta$ and $\alpha_1 = \alpha_2 = \alpha$ and set $\mu_0 = \pi/2$, so that

$$\begin{pmatrix} \alpha & \beta \\ -\gamma & -\alpha \end{pmatrix}$$

- ❖ By comparing terms, the parameters of the insertion can be solved as,

$$s_1 = \frac{1}{\gamma}, \quad s_2 = \frac{\alpha^2}{\gamma} \quad \text{and} \quad \delta = \frac{\gamma}{\alpha} \quad (3.14)$$

- ❖ To be valid in both planes simultaneously,

$$\alpha_x = -\alpha_z = \pm\alpha \quad \text{and} \quad \beta_x = \beta_z = \beta \quad (3.15)$$

Collins insertion continued

- ❖ The Collins insertion or module with $\pi/2$ phase advance complements the modules defined earlier with π and 2π phase advances.
- ❖ It lacks flexibility, but could be useful in specific situations. Two examples based on FODO lattices :

❖ Collins insertion in a $2\pi/3$ FODO lattice

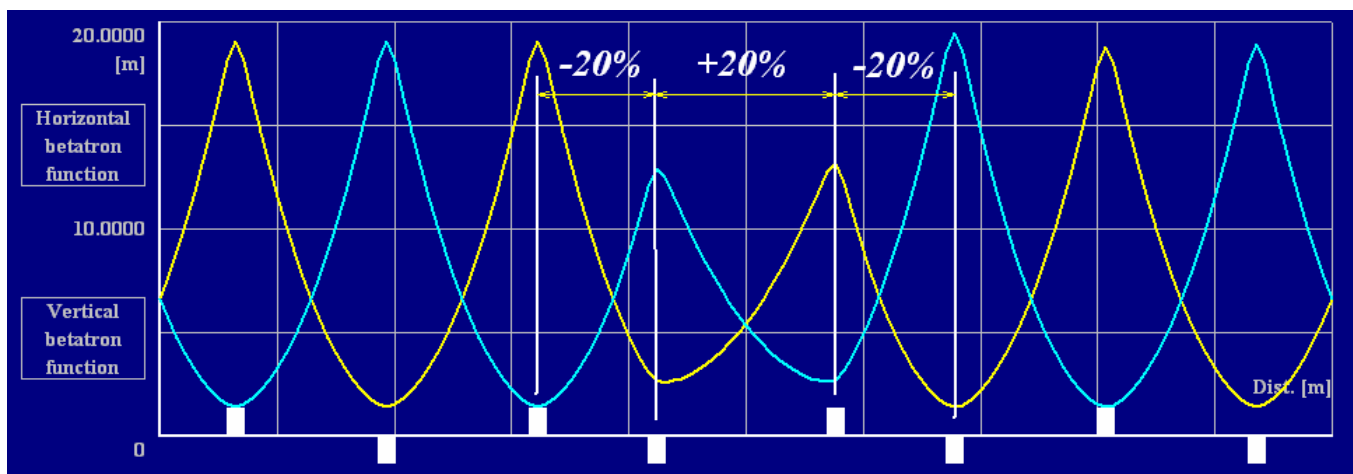

❖ Collins insertion in a $\pi/4$ FODO lattice

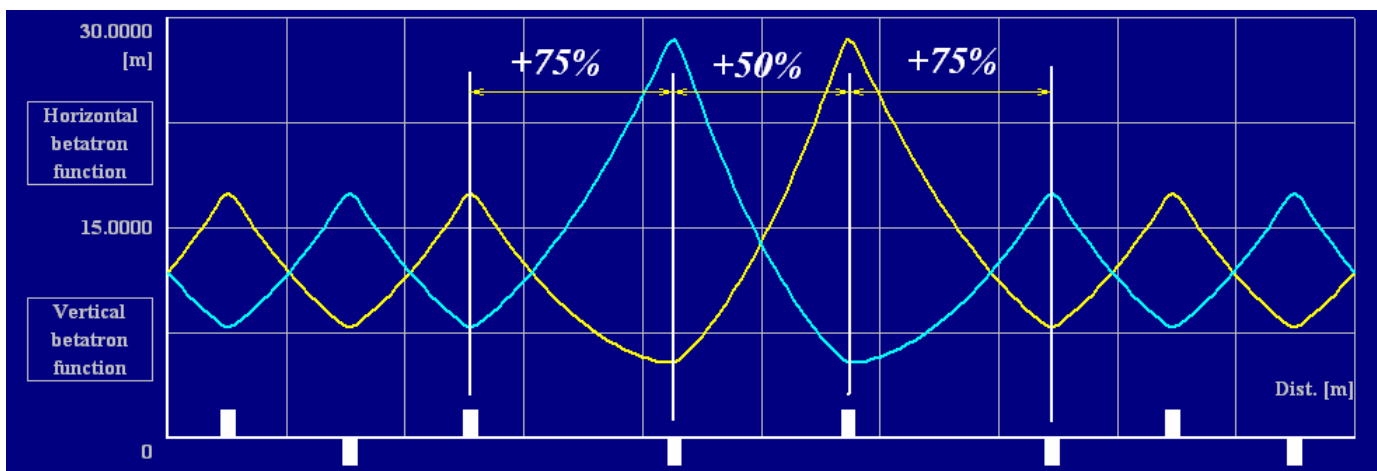

Since these are thin lens modules, the above examples required one pass of numerical matching to refine the results.

Thin-lens FODO

The thin-lens analysis of a matched FODO cell is a classic exercise and a source of exam questions.

❖ **Case 1 Matrices between symmetry planes at mid-Fs.**

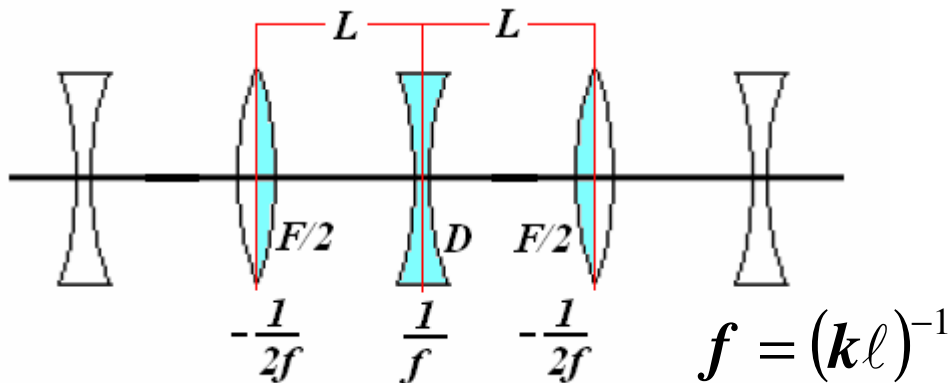

$$\begin{pmatrix} 1 & 0 \\ \mp \frac{1}{2f} & 1 \end{pmatrix} \begin{pmatrix} 1 & L \\ 0 & 1 \end{pmatrix} \begin{pmatrix} 1 & 0 \\ \pm \frac{1}{f} & 1 \end{pmatrix} \begin{pmatrix} 1 & L \\ 0 & 1 \end{pmatrix} \begin{pmatrix} 1 & 0 \\ \mp \frac{1}{2f} & 1 \end{pmatrix}$$

where the upper/lower signs correspond to horizontal/vertical planes respectively.

Multiplying out and comparing to the equivalent Twiss matched-cell transfer matrix,

$$\begin{pmatrix} 1 - \frac{L^2}{2f^2} & 2L \left(1 \pm \frac{L}{2f} \right) \\ -\frac{L}{2f^2} \left(1 \mp \frac{L}{2f} \right) & 1 - \frac{L^2}{2f^2} \end{pmatrix} \equiv \begin{pmatrix} \cos \mu_0 + \alpha \sin \mu_0 & \beta \sin \mu_0 \\ -\frac{(1 + \alpha^2)}{\beta} \sin \mu_0 & \cos \mu_0 - \alpha \sin \mu_0 \end{pmatrix}$$

but $\alpha = 0$ on symmetry plane.

Thin-lens FODO continued

❖ Comparing the terms and solving gives,

$$\cos \mu_0 = 1 - \frac{L^2}{2f^2} \quad \text{so that} \quad \sin \frac{\mu_0}{2} = \frac{L}{2f}$$

$$\beta = 2L \frac{[1 \pm \sin(\mu_0/2)]}{\sin \mu_0} \quad \text{and} \quad \alpha = 0 \quad (3.16)$$

so that

$$\beta_{\max} = 2L \frac{[1 + \sin(\mu_0/2)]}{\sin \mu_0}$$

$$\beta_{\min} = 2L \frac{[1 - \sin(\mu_0/2)]}{\sin \mu_0} \quad (3.17)$$

❖ Case 2 Parameters at mid-straight sections.

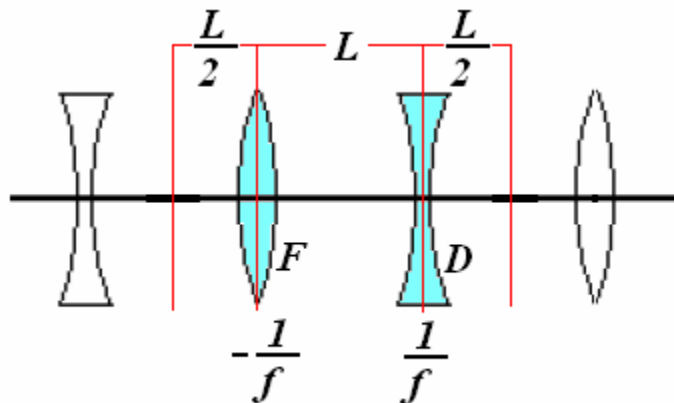

$$\begin{pmatrix} 1 & L/2 \\ 0 & 1 \end{pmatrix} \begin{pmatrix} 1 & 0 \\ \mp 1/f & 1 \end{pmatrix} \begin{pmatrix} 1 & L \\ 0 & 1 \end{pmatrix} \begin{pmatrix} 1 & 0 \\ \pm 1/f & 1 \end{pmatrix} \begin{pmatrix} 1 & L/2 \\ 0 & 1 \end{pmatrix}$$

Thin-lens FODO continued

$$\begin{pmatrix} 1 + \frac{L}{f} - \frac{L^2}{2f^2} & 2L - \frac{L^3}{4f^2} \\ -\frac{L}{f^2} & 1 - \frac{L}{f} - \frac{L^2}{2f^2} \end{pmatrix} \equiv \begin{pmatrix} \cos \mu_0 + \alpha \sin \mu_0 & \beta_m \sin \mu_0 \\ -\frac{(1 + \alpha^2)}{\beta_m} \sin \mu_0 & \cos \mu_0 - \alpha \sin \mu_0 \end{pmatrix}$$

- ❖ Comparing the terms and solving gives the same phase advance as before, as would be expected,

$$\cos \mu_0 = 1 - \frac{L^2}{2f^2} \quad \text{so that} \quad \sin \frac{\mu_0}{2} = \frac{L}{2f}$$

- ❖ and the mid-point beta and alpha values are

$$\begin{aligned} \beta_m &= \frac{2L}{\sin \mu_0} \left[1 - \frac{1}{2} \sin^2 \left(\frac{\mu_0}{2} \right) \right] \\ \alpha_m &= \frac{2}{\sin \mu_0} \left[\sin \left(\frac{\mu_0}{2} \right) \right] \end{aligned} \quad (3.18)$$

Analytical matching

- ❖ Very few matching insertions have been, or can be, solved analytically. One example is a doublet of the form

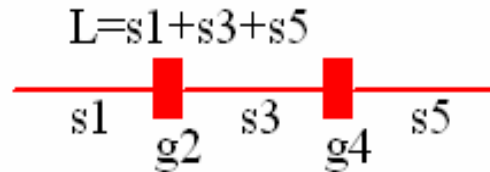

It matches α_x , β_x , α_y and β_y and shows solutions and near-solutions with the mismatch. It also shows the non-existence of solutions.

- ❖ Another example is a triplet of the form

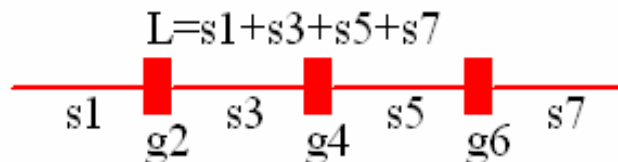

This is the most powerful and useful insertion available. It matches α_x , β_x , α_y , β_y and D_x and gives exact solutions or signals their non-existence.

- ❖ Another example is a quadruplet (similar to the triplet in terms of performance) of the form

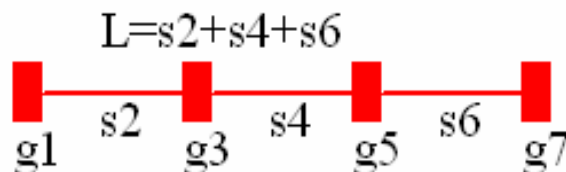

- ❖ The disadvantage is that the above all rely on thin lenses and require a second stage with numerical matching to convert to thick lenses.
- ❖ The advantage is that they provide good starting points for the numerical matching.
- ❖ These routines are included on the CD-ROM ...

Numerical matching

❖ **Some recommendations:**

- ❖ Try to arrange the module for matching to be between symmetry planes so that the alphas are zero.
- ❖ Always perform the matching with the smallest sub-section of lattice possible.
- ❖ Modular structures work more understandably and usually more efficiently.
- ❖ Try to choose orthogonal parameters.
- ❖ Be patient, it may takes days.
- ❖ An extra variable with tight limits can add fluidity and then be matched out at the very end.

❖ **Some truths:**

- ❖ In most cases, you will never know if there is a better match.
- ❖ Keep in mind the model of lakes scattered along multiple valleys. Often the problem is to escape from a local minimum. Restart the matching, or alter steps, or shift the starting point by a small fraction, or “walk” the solution via intermediate points.
- ❖ It is usual to squash the mismatch function to 10^{-15} , but in practice small errors will always dominate this ideal solution.