

# ***TWISS and BEYOND***

***Lecture 6  
January 2017***

***P.J. Bryant***

# Radiation and the lattice

❖ Synchrotron radiation will be treated in detail in later lectures, but it is useful to collect together those results that interest the lattice designer.

❖ ‘Dispersion invariant’ and ‘Radiation Integrals’:

$$\begin{aligned}
 H(s) &= \gamma_x D_x^2 + 2\alpha_x D_x D'_x + \beta_x D'_x{}^2 \\
 I_1 &= \oint \frac{D_x(s)}{\rho^2(s)} ds; & I_2 &= \oint \frac{1}{\rho^2(s)} ds; & I_3 &= \oint \frac{1}{|\rho^3(s)|} ds; \\
 I_4 &= \oint \frac{D_x(s)}{\rho^3(s)} [\Lambda - 2\rho^2(s)k(s)] ds; & I_5 &= \oint \frac{H(s)}{|\rho^3(s)|} ds; & & (6.1)
 \end{aligned}$$

where  $\Lambda=1$  for sector dipoles and  $\Lambda=0$  for rectangular dipoles.

❖ These are used to evaluate:  $\alpha$  = mom. compaction;  $U_\gamma$  = energy loss/turn;  $\tilde{D}(s)$  = lattice damping const.;  $J_x, J_y, J_s$  = damping partition nos;  $\sigma, E_x$  = equilibria.

$$\begin{aligned}
 \alpha &= I_1 / C; & U_\gamma &= \frac{2}{3} r_c m_0 c^2 \gamma^4 I_2; & \tilde{D} &= I_4 / I_2; \\
 J_x &= 1 - I_4 / I_2; & J_y &= 1; & J_l &= 1 + I_4 / I_2; \\
 \sigma_{s,eq} &= \frac{55}{32\sqrt{3}} \frac{\hbar}{m_0 c^2} \left[ \frac{E^2}{m_0 c^2} \right]^2 \left[ \frac{I_3}{2I_2 + I_4} \right]; \\
 E_{x,eq} &= \frac{55\pi}{32\sqrt{3}} \frac{\hbar}{m_0 c^2} \left[ \frac{E^2}{m_0 c^2} \right]^2 \left[ \frac{I_5}{I_2 - I_4} \right]; & & & (6.2)
 \end{aligned}$$

# Controlling the emittance

- ❖ The performance of a light source is largely determined by the horizontal beam emittance, where the balance between excitation and damping depends on  $H(s)$ ,  $D_x(s)$ ,  $k(s)$  and  $\rho(s)$ , all of which depend totally on the lattice.

$$E_{x,eq} = A \left[ \frac{\oint \frac{H(s)}{|\rho^3(s)|} ds}{\oint \frac{1}{\rho^2(s)} ds - \oint \frac{D_x(s)}{\rho^3(s)} [\Lambda - 2\rho^2(s)k(s)] ds} \right]$$

where

$$A = \frac{55\pi}{32\sqrt{3}} \frac{\hbar}{m_0 c^2} \left[ \frac{E^2}{m_0 c^2} \right]^2.$$

- ❖ We can reasonably assume that all the dipoles are identical rectangular bends with a bending radius  $\rho_0$  and a constant gradient  $k_0$ . Furthermore, outside the dipoles  $\rho = \infty$  reducing the contributions to the integrals to zero, so that,

$$E_{x,eq} = A \left[ \frac{\int_{\text{Dipole}} H(s) ds}{L\rho_0 + 2\rho_0^2 k_0 \int_{\text{Dipole}} D_x(s) ds} \right] \quad (6.3)$$

where  $L$  is the length of a dipole.

# Controlling the emittance continued

- ❖ Finally, if the dipole has no gradient, then

$$E_{x,eq} = A \left[ \frac{1}{L\rho_0} \int_{\text{Dipole}} H(s) ds \right] \quad (6.4)$$

- ❖ Thus the smallest emittances in both (6.3) and (6.4) will be obtained by making the integral of  $H(s)$  in the dipole as small as possible.
  - ❖ If the dipole has a gradient it helps if  $\rho_0$  is large. There appears to be a conflict with  $D_x$  that needs to be small for the numerator in (6.3) and (6.4) and large for the denominator in (6.3), but this will be resolved later.
- ❖ For the evaluation of  $H(s)$ ,
    - ❖ From Lecture 1 Eqn (1.19)

$$\begin{pmatrix} \beta(s) \\ \alpha(s) \\ \gamma(s) \end{pmatrix} = \begin{pmatrix} t_{11}^2 & -2t_{11}t_{12} & t_{12}^2 \\ -t_{11}t_{21} & [t_{11}t_{22} + t_{12}t_{21}] & -t_{12}t_{22} \\ t_{21}^2 & -2t_{21}t_{22} & t_{22}^2 \end{pmatrix} \begin{pmatrix} \beta(0) \\ \alpha(0) \\ \gamma(0) \end{pmatrix} \quad (1.19)$$

- ❖ Also from Lecture 1,

$$\begin{pmatrix} D(s) \\ D'(s) \\ 1 \end{pmatrix} = \begin{pmatrix} t_{11} & t_{12} & t_{13} \\ t_{21} & t_{22} & t_{23} \\ 0 & 0 & 1 \end{pmatrix} \begin{pmatrix} D(0) \\ D'(0) \\ 1 \end{pmatrix}$$

# Controlling the emittance continued

- ❖ Since we want zero dispersion in the straight sections and dispersion bumps between pairs of dipoles, we can put  $D_x(0) = D'_x(0) = 0$  on the input side of the dipole. This fixes  $D_x$  and resolves the conflict mentioned earlier.

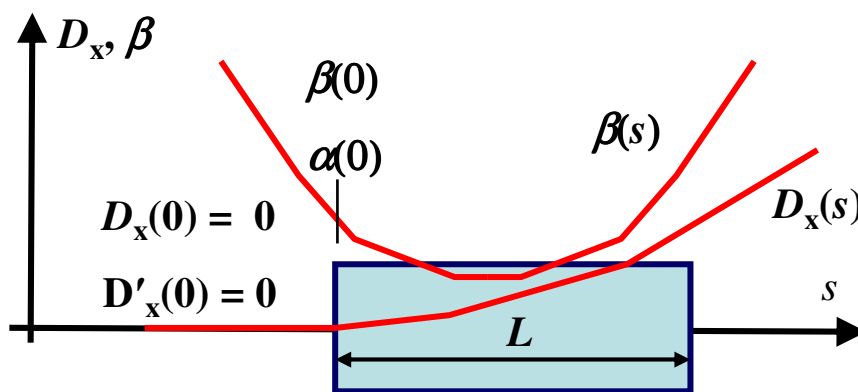

- ❖ For a horizontal bending dipole, for which we neglected the weak focusing term  $1/\rho^2$ , but keep  $k$ ,

$$\begin{aligned}
 t_{11} &= t_{22} = \cos(\sqrt{|k|}s) & (k < 0); & & t_{11} &= t_{22} = \cosh(\sqrt{|k|}s) & (k > 0) \\
 t_{12} &= \frac{1}{\sqrt{|k|}} \sin(\sqrt{|k|}s) & (k < 0); & & t_{12} &= \frac{1}{\sqrt{|k|}} \sinh(\sqrt{|k|}s) & (k > 0) \\
 t_{21} &= -\sqrt{|k|} \sin(\sqrt{|k|}s) & (k < 0); & & t_{21} &= \sqrt{|k|} \sinh(\sqrt{|k|}s) & (k > 0) \\
 t_{13} &= \frac{1}{\rho_0} \frac{1}{|k|} [1 - \cos(\sqrt{|k|}s)] & (k < 0); & & t_{13} &= \frac{1}{\rho_0} \frac{1}{|k|} [\cosh(\sqrt{|k|}s) - 1] & (k > 0) \\
 t_{23} &= \frac{1}{\rho_0} \frac{1}{\sqrt{|k|}} \sin(\sqrt{|k|}s) & (k < 0); & & t_{23} &= \frac{1}{\rho_0} \frac{1}{\sqrt{|k|}} \sinh(\sqrt{|k|}s) & (k > 0)
 \end{aligned}$$

**where  $k < 0$  is focusing and  $k > 0$  is defocusing.** (6.5)

# Controlling the emittance continued

❖ When  $k = 0$ , this quickly reduces to,

$$\begin{aligned}
 t_{11} &= 1; & t_{12} &\approx s; & t_{21} &= 0; & t_{13} &\approx \frac{s^2}{2\rho_0}; & t_{23} &\approx \frac{s}{\rho_0}; \\
 D_x(s) &= D_x(0) + sD'_x(0) + \frac{s^2}{2\rho_0}; & D'_x(s) &= D'_x(0) + \frac{s}{\rho_0}; \\
 \beta(s) &= \beta(0) + 2\alpha(0)s + \gamma(0)s^2; & \alpha(s) &= \alpha(0) - s\gamma(0); \\
 \gamma(s) &= \gamma(0) = \text{constant.} & & & & & & & & (6.6)
 \end{aligned}$$

❖ In this case, the dispersion invariant  $H(s)$  becomes,

$$H(s) = \frac{1}{\rho_0^2} \left( \frac{\gamma(0)}{4} s^4 - \alpha(0)s^3 + \beta(0)s^2 \right)$$

and its integral through the dipole,

$$\int_0^L H(s) ds = \frac{L^2}{\rho_0^2} \left( \frac{1 + \alpha^2(0)}{20\beta(0)} L^3 - \frac{\alpha(0)}{4} L^2 + \frac{\beta(0)}{3} L \right)$$

❖ To find the minimum in  $H(s)$  (and hence the smallest emittance)

$$\frac{\partial}{\partial \alpha} \left( \frac{1 + \alpha^2}{20\beta} L^3 - \frac{\alpha}{4} L^2 + \frac{\beta}{3} L \right) = \frac{\alpha}{10\beta} L^3 - \frac{L^2}{4} = 0$$

$$\frac{\partial}{\partial \beta} \left( \frac{1 + \alpha^2}{20\beta} L^3 - \frac{\alpha}{4} L^2 + \frac{\beta}{3} L \right) = \frac{L}{3} - \frac{(1 + \alpha^2)L^3}{20\beta^2} = 0$$

# *Controlling the emittance continued*

- ❖ The partial differentials yield 2 conditions for minimum  $H(s)$ , Ref. [6.1],

$$\beta(0) = \frac{2\sqrt{3}}{\sqrt{5}} L = 1.549L$$
$$\alpha(0) = \sqrt{15} = 3.873; \quad (6.7)$$

- ❖ This is the principle used by Rena Chasman and Ken Green for the Double Bend Achromat that launched the 3<sup>rd</sup> generation of light sources.
- ❖ Note that the previous slides leave open certain side issues.
  - ❖ It should not be too difficult to extend this theory for dipoles with a finite dispersion at the entry.
  - ❖ What effect would a focusing or defocusing gradient have?
  - ❖ Is it possible to solve the complete problem using the full expressions for the matrix elements with finite dispersion at the entry?

# Matching Chasman-Green Ref. [6.2]

- ❖ The smallest repeatable structure is the half superperiod: ( F D O F ).

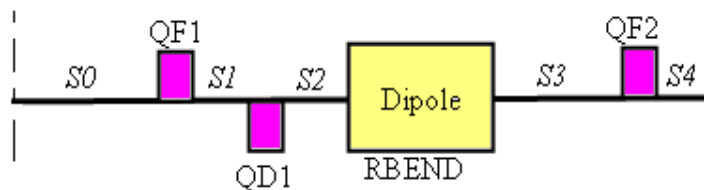

- ❖ The entry and exit planes are symmetry planes and the entry plane is dispersion free, so

$$\alpha_x = \alpha_z = D'_x = D'_z = 0 \quad \text{Input and output}$$

$$D_x = D_z = 0 \quad \text{Input}$$

- ❖ The number of cells fixes the bending angle.

$$\text{Dipole bending angle} = \frac{2\pi}{2N_{\text{Superperiods}}}$$

- ❖ The goal is to make  $\beta_x$  and  $D_x$  as small as possible within the dipole.  $D_x$  starts from zero and there is little margin for adjustment. For  $\alpha_x$  and  $\beta_x$ , there are intermediate matching conditions at the entry to the dipole.

$$\alpha_x = 3.873$$

$$\beta_x = 1.549 \times \text{Dipole length}$$

- ❖ However,  $\alpha = 3.873$  is likely to be unstable, so relax this condition and try to reach 3.0. The example on the next slide needs this refinement.



# Matching Chasman-Green continued

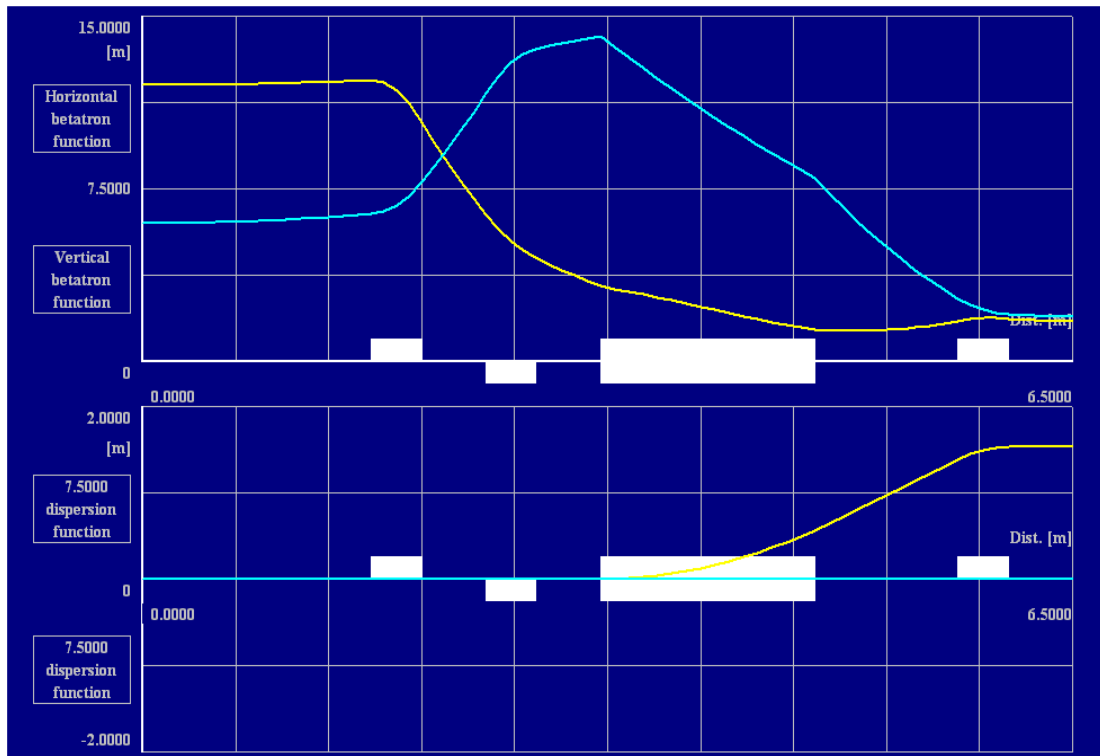

The above shows a possible solution found with WinAGILE. The input ratio  $\beta_z / \beta_x$  is around 0.5, which is characteristic of one family of solutions. Other families with  $\beta_z \cong \beta_x$  or much larger or smaller values are also possible.

- ❖ Note how  $\beta_x$  is kept small inside the dipole. It is also kept small inside the dispersion bump to ensure the  $\pi$  phase advance to close the bump.
- ❖ Note WinAGILE also calculates the synchrotron radiation integrals, partition numbers, emittances and lists the radiation from all elements and includes some insertion devices.

# *w*-Vector

- ❖ Global chromaticity schemes (Lecture 4) ensure beam stability and control of the working line.
- ❖ The ‘achromatic quadrupole’ (Lecture 4) provides a possibility for local chromatic correction. **Unfortunately, this method lacks flexibility and is ineffective in regions of zero dispersion.**
- ❖ The so-called *w*-vector offers a method for showing chromatic effects quantitatively and providing a tool for designing local compensation schemes Ref. [6.3]. Such schemes are especially needed for:
  - ❖ Low- $\beta$  insertions since the innermost quadrupoles are very strong and sit in a dispersion-free region.
  - ❖ **Light source cells because the two beams can present significantly different momenta depending on the ‘sawtooth’ mentioned in Lecture 3.**
- ❖ We define new variables (for 1 plane at a time):

$$B = \frac{(\beta_1 - \beta_0)}{(\beta_0 \beta_1)^{1/2}} \quad \text{and} \quad A = \frac{(\alpha_1 \beta_0 - \alpha_0 \beta_1)}{(\beta_0 \beta_1)^{1/2}}$$
$$\psi = \frac{1}{2}(\mu_0 + \mu_1) \quad \text{and} \quad \Delta K = (K_1 - K_0) \quad (6.8)$$

## *w-Vector continued*

where subscript 0 refers to the central orbit and subscript 1 to an off-axis orbit with momentum deviation  $\Delta p/p$ .  $K$  is the generalized focusing constant in the motion equation.

$$\frac{d^2 z}{ds^2} + K(s)z = 0$$

- ❖ The usual basic relations apply on each orbit including the equation (1.7) from Lecture 1:

$$\frac{d\mu_{0,1}}{ds} = \frac{1}{\beta_{0,1}} \quad \text{and} \quad \frac{d\beta_{0,1}}{ds} = -2\alpha_{0,1}$$
$$\frac{d^2 \sqrt{\beta_{0,1}}}{ds^2} + K_{0,1}(s)\sqrt{\beta_{0,1}} = \left(\sqrt{\beta_{0,1}}\right)^{-3} \quad (1.7)$$

and reducing the double differential in (1.7) gives

$$\frac{d\alpha_{0,1}}{ds} = \beta_{0,1} K_{0,1}(s) - \frac{(1 + \alpha_{0,1}^2)}{\beta_{0,1}} \quad (6.9)$$

- ❖ We now have all the tools needed to differentiate  $B$  and  $A$  with respect to  $s$ . These manipulations are too lengthy to do here, but they are reasonably straightforward.

## *w-Vector continued*

- ❖ The following equations can be found:

$$\begin{aligned}\frac{dB}{ds} &= -2A \frac{d\psi}{ds} \\ \frac{dA}{ds} &= 2B \frac{d\psi}{ds} + (\beta_0 \beta_1)^{1/2} \Delta K\end{aligned}\quad (6.10)$$

- ❖ It follows that when  $\Delta K = 0$  (achromatic region):

$$\begin{aligned}\frac{dB}{d\psi} &= -2A & \text{and} & & \frac{dA}{d\psi} &= 2B \\ \frac{d^2 B}{d\psi^2} + 4B &= 0 & \text{and} & & \frac{d^2 A}{d\psi^2} + 4A &= 0 \\ A^2 + B^2 &= \text{Constant}\end{aligned}\quad (6.11)$$

- ❖ Thus  $A$  and  $B$  oscillate sinusoidally at twice the average betatron frequency in an achromatic region.
- ❖ The term  $\Delta K$  holds all the achromatic errors between the two orbits. When an error  $\Delta K$  is encountered it manifests itself as a kick in  $A$  that can be evaluated from (6.10). The disturbance to  $A$  and  $B$  propagate into the next achromatic section according to (6.11).
- ❖ **Thus far the theory is exact!**

# *w-Vector continued*

- ❖ We now normalize  $A$  and  $B$  by  $\Delta p/p$  and define new chromatic variables  $a$ ,  $b$  and  $w$  as  $\Delta p/p \rightarrow 0$ .

$$a = \underbrace{\text{Limit}}_{\Delta p/p \rightarrow 0} \frac{A}{\Delta p/p} \quad \text{and} \quad b = \underbrace{\text{Limit}}_{\Delta p/p \rightarrow 0} \frac{B}{\Delta p/p}$$

$$\Delta K = \underbrace{\text{Limit}}_{\Delta p/p \rightarrow 0} \frac{-\Delta K}{\Delta p/p} \quad \text{and} \quad \psi \rightarrow \mu$$

$$w = (b + ja) \tag{6.12}$$

**Note:** WinAGILE calculates  $w=b+ja$  for the  $\Delta p/p$  given by the user. Make  $\Delta p/p$  small to reach limiting value.

- ❖ Below are some examples of the  $w$ -vector in a FODO cell: (a) Uncompensated, (b) With compensating sextupole gradients in the quadrupoles and (c) With the D-sextupole making only a partial correction.

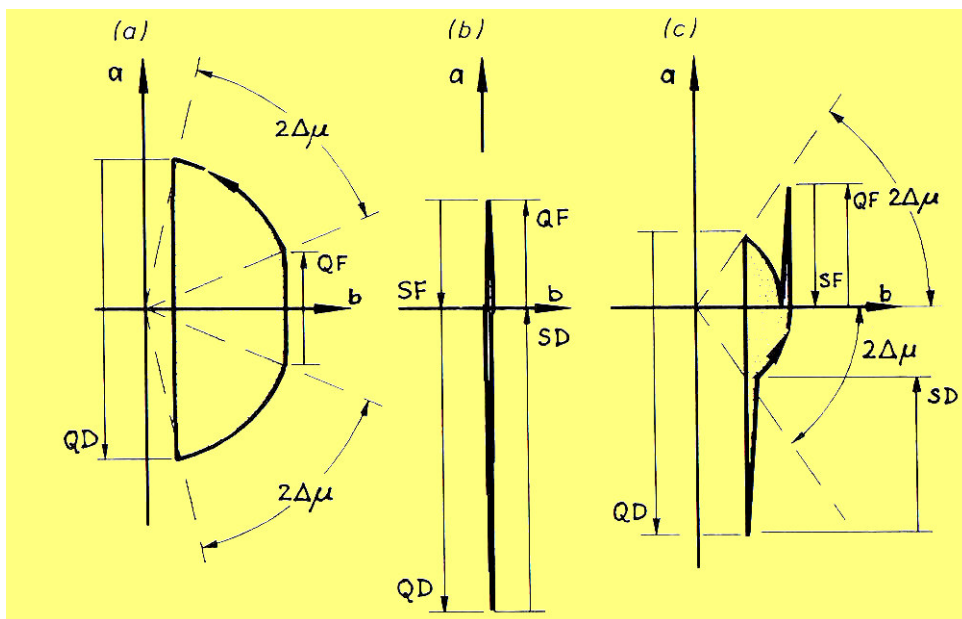

## *w-Vector continued*

- ❖ Before resorting to the computer to plot  $a$  and  $b$  there are some thin lens approximations that can be useful and informative. For thin lenses,  $\Delta b = 0$  and  $\Delta a$  at the lens ( $\psi=0$ ) and :

$$\text{Quadrupole: } \Delta a(0) = -(\beta_0 \beta_1)^{1/2} \Delta k \Delta s \approx \beta_0 k_0 \ell_q$$

$$\text{Sextupole: } \Delta a(0) = -(\beta_0 \beta_1)^{1/2} \Delta k \Delta s \approx -\beta_0 D_x k_n^1 \ell_s \quad (6.13)$$

where  $k_0$  is the normalised quadrupole gradient and  $k_n^1$  the normalised sextupole gradient.

- ❖ The thin lens errors will then propagate as,

$$\text{Quad.: } \Delta b(\mu) = \Delta b(0) \sin(2\psi) \approx \beta_0 k_0 \ell_q \sin(2\mu)$$

$$\Delta a(\mu) = \Delta a(0) \cos(2\psi) \approx \beta_0 k_0 \ell_q \cos(2\mu)$$

$$\text{Sext.: } \Delta b(\mu) = \Delta b(0) \sin(2\psi) \approx -\beta_0 D_x k_n^1 \ell_s \sin(2\mu)$$

$$\Delta a(\mu) = \Delta a(0) \cos(2\psi) \approx -\beta_0 D_x k_n^1 \ell_s \cos(2\mu) \quad (6.14)$$

- ❖ Thus, it is possible to make a chromatic correction at a specific point with 2 sextupoles per plane.

Note  $K$ ,  $k_0$  and  $k_n^1$  change signs between planes.

The unaddressed problem is resonance excitation. We have no time in this lecture to study resonance correction schemes, but we will look at dynamic aperture, which is the ultimate performance check.

# *w-Vector continued*

## ❖ For a low- $\beta$ insertion in a collider

It is necessary to allow the chromatic error from the strong quadrupoles to propagate through the dispersion-free straight section to the arc.

## ❖ In the arc, a series of sextupoles can progressively step the error down to zero. Try to design the series to reduce resonance excitation by having;

- ❖ An even number of sextupoles in each family,
- ❖ A betatron phase advance of  $\pi/3$  between units.
- ❖ The F sextupoles  $\beta_x/\beta_z$  should be equal for all members and be as large as possible.
- ❖ The D sextupoles  $\beta_z/\beta_x$  should be equal for all members and be as large as possible.

## ❖ See scheme below that starts with $w = 0$ at the crossing point.

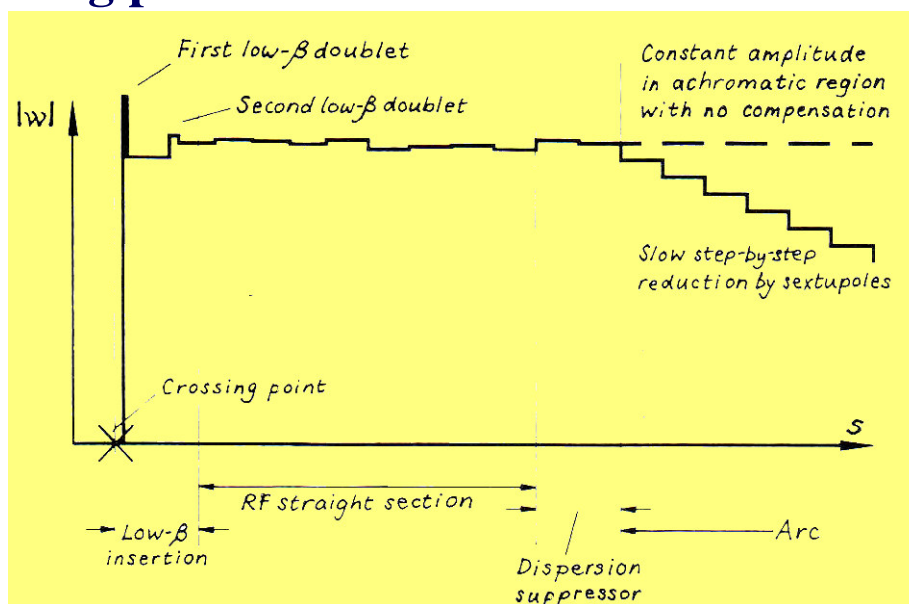

# *w-Vector continued*

- ❖ **For a cell in a light source**
  - ❖ The chromatic errors are generated inside the dispersion bump. The dipole can also contribute if it has a built-in gradient.
  - ❖ The aims are to have zero error propagating into the long straight for the insertions and minimum error in the dipole where the high-brightness condition is applied.
  - ❖ In the closely packed cell of a light source, one has very little choice over where to place sextupoles.
  - ❖ Plotting the  $w$ -vector will give a view of the chromatic errors and the effects of the sextupoles.
  - ❖ The resonance excitation can be calculated separately (routines in WinAGILE) and the overall effect can be also be evaluated by calculating the dynamic aperture.

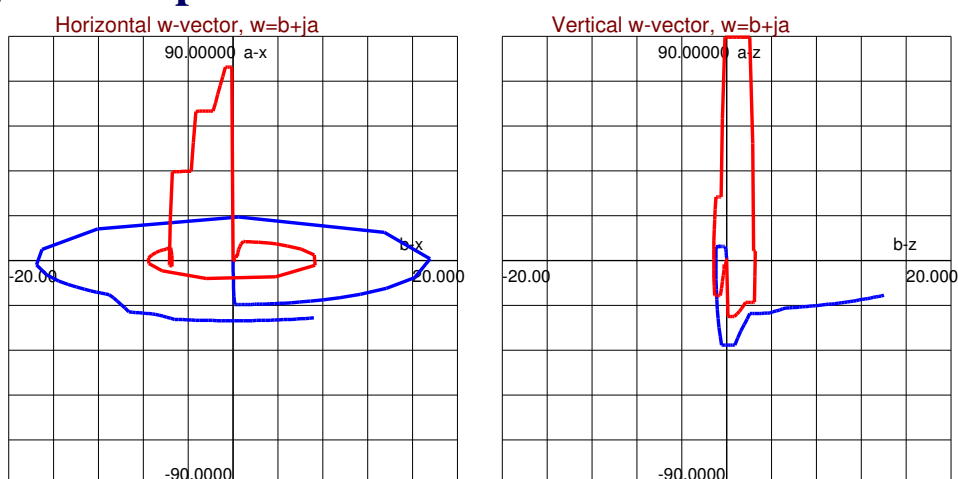

**Correction of a half a DBA cell. Blue curves are open showing  $w$ -vectors entering straight section. Red curves are closed and go to zero.**



# Dynamic aperture

- ❖ The introduction of sextupoles into a lattice to correct chromaticity is usually the first major source of non-linearity and the first threat to the *Dynamic Aperture*.
- ❖ The Dynamic Aperture refers to the 4D surface limiting the region of long-term stability around the axis.
- ❖ Theoretically, a lattice is stable for an infinite number of turns within the Dynamic Aperture, but as the oscillation amplitudes increase beyond this limit the ion will be stable for fewer and fewer turns. This is described by the empirical formula for  $N$  turns,

$$x_{\text{Stable}}(N) = x_{\text{Stable}}(\infty) \left[ 1 + \frac{b}{\log_{10} N} \right] \quad (6.15)$$

- ❖ To find the Dynamic Aperture, increase the initial oscillation amplitude in regular steps and track for say 2'000 turns at each step until the first unstable position is found. Repeat for 10'000 turns and 20'000 turns. With this data use equation (6.15) to extrapolate to the stability limit for an infinite number of turns and test with say 50'000 turns.

## *Dynamic aperture continued*

- ❖ In theory, the Dynamic Aperture is a complete shell in 4D phase space, so the starting conditions used to probe the stability are not critical.
- ❖ Although the 4D shell has a complex shape, we would like to ascribe a single value to this object and it is customary to use the radius of the equivalent 4D sphere in phase space. However, finding the true 4D volume of the Dynamic Aperture is not trivial, but equally it is not critical, so we can use the 4D emittance which is relatively easy to evaluate.
- ❖ **Example:**

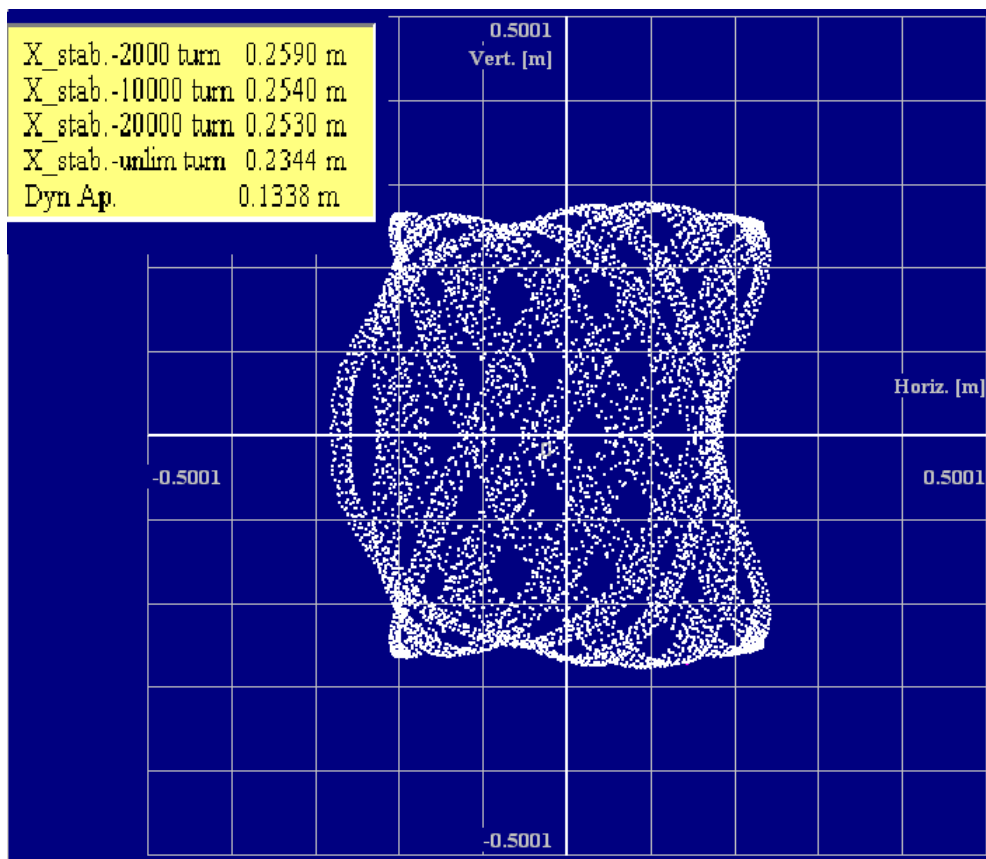

# *Möbius lattice*

We may use the idea of the Möbius lattice in the Mini-workshop. Möbius is basically a coupling problem and there are 3 methods for handling coupling:

- ❖ **Treat the coupling as a perturbation**  
BUT this is no good for Möbius which requires 100% coupling.
- ❖ **Use the so-called Sigma Matrices**  
Since they are widely used and important to know, they will be described in the next few slides.
- ❖ **Use the Teng-Edwards formulation**  
This is less well-known, little used and the theory is advanced and too long to be explained here. However, we can still try using the method.

We note that:

- ❖ **WinAGILE computes all 3 methods.**
- ❖ **When the Teng-Edwards coupling angle is zero, the normal modes degenerate into the familiar Twiss modes.**
- ❖ **For weak coupling, the  $u$  and  $v$  modes (known as the nearly-horizontal and nearly-vertical modes) will be close to the Twiss modes.**
- ❖ **In general the  $u$  and  $v$  modes contain horizontal and vertical components and appear as tilted 4D ellipsoids.**

# *Sigma matrices*

- ❖ The  $\sigma$ -matrix formalism makes statistical averages over the beam distribution. It also provides statistical definitions for the Twiss functions.
- ❖ Let  $u$  be a vector containing the transverse phase-space co-ordinates of a particle. The statistical averages that describe a distribution of particles in phase space are then contained in the covariance  $\sigma$ -matrix defined as,

*Definition of  $\sigma$ -matrix,*

$$\sigma = \langle u u^T \rangle$$

$$\sigma = \left\langle \begin{pmatrix} x \\ x' \\ y \\ y' \end{pmatrix} \begin{pmatrix} x & x' & y & y' \end{pmatrix} \right\rangle = \begin{pmatrix} \langle x^2 \rangle & \langle xx' \rangle & \langle xy \rangle & \langle xy' \rangle \\ \langle x'x \rangle & \langle x'^2 \rangle & \langle x'y \rangle & \langle x'y' \rangle \\ \langle yx \rangle & \langle yx' \rangle & \langle y^2 \rangle & \langle yy' \rangle \\ \langle y'x \rangle & \langle y'x' \rangle & \langle y'y \rangle & \langle y'^2 \rangle \end{pmatrix} \quad (6.16)$$

## *Sigma matrices continued*

- ❖ In equation (6.16), the  $\langle \dots \rangle$  brackets indicate the estimators for the expectation values for the moments of the  $N$  particles in the beam.

$$\langle x \rangle = \frac{1}{N} \sum_{i=1}^N x_i$$

$$\langle x^2 \rangle = \frac{1}{N-1} \sum_{i=1}^N (x_i - \langle x \rangle)^2 \quad (6.17)$$

$$\langle xy \rangle = \frac{1}{N-1} \sum_{i=1}^N (x_i - \langle x \rangle)(y_i - \langle y \rangle); \quad \text{etc.}$$

- ❖ Note that tacitly we have slipped into a formalism that accepts transversely coupled beams.
- ❖ Note that in (6.16), the matrix elements  $\{1,1\}$  and  $\{3,3\}$  give the 1-sigma beam width and one-sigma beam height respectively throughout the lattice even in the presence of coupling.

## *Sigma matrix transfer rule*

- ❖ To derive the transformation properties of the  $\sigma$ - matrix , let  $M$  represent the usual lattice transfer matrix, or a rotation matrix, such that,

$$\mathbf{u}_2 = M \mathbf{u}_1$$

- ❖ The use of this linear transformation with the definition of the  $\sigma$ - matrix (6.16) and the standard relation  $(a.b)^T = b^T.a^T$  gives

$$\sigma_2 = \underbrace{\langle \mathbf{u}_2 \mathbf{u}_2^T \rangle}_{\sigma_2} = \langle M \mathbf{u}_1 (M \mathbf{u}_1)^T \rangle = M \underbrace{\langle \mathbf{u}_1 \mathbf{u}_1^T \rangle}_{\sigma_1} M^T$$

$$\text{Transfer rule, } \sigma_2 = M \sigma_1 M^T \quad (6.18)$$

- ❖ Thus the  $\sigma$ - matrix at one point in a lattice can be transmitted to any other point **and this includes lattices with sections rotated about their axes and sections with coupling.**

## *$\sigma$ -matrix motion invariant*

❖ Assuming  $\sigma^{-1}$  exists, consider,

$$W = \mathbf{u}^T \sigma^{-1} \mathbf{u} \quad (6.19)$$

Evaluate  $W$  at two positions related by

$$\mathbf{u}_2 = M \mathbf{u}_1$$

$$W_2 = \mathbf{u}_2^T \sigma_2^{-1} \mathbf{u}_2 = (M \mathbf{u}_1)^T \sigma_2^{-1} (M \mathbf{u}_1) = \mathbf{u}_1^T M^T \sigma_2^{-1} M \mathbf{u}_1$$

❖ With (6.18) and  $(a b c)^{-1} = c^{-1} b^{-1} a^{-1}$ ,

$$\sigma_2^{-1} = (M \sigma_1 M^T)^{-1} = (M^T)^{-1} \sigma_1^{-1} M^{-1}$$

❖ After substitution

$$\begin{aligned} W_2 &= \mathbf{u}_2^T \sigma_2^{-1} \mathbf{u}_2 = \mathbf{u}_1^T \underbrace{M^T (M^T)^{-1}}_I \sigma_1^{-1} \underbrace{M^{-1} M}_{I} \mathbf{u}_1 \\ &= \mathbf{u}_1^T \sigma_1^{-1} \mathbf{u}_1 = W_1 \end{aligned}$$

*$W$  is the sigma invariant,*

$$W = \mathbf{u}_2^T \sigma_2^{-1} \mathbf{u}_2 = \mathbf{u}_1^T \sigma_1^{-1} \mathbf{u}_1 \quad (6.20)$$

# $\sigma$ -matrix for an uncoupled beam

❖ Consider an uncoupled beam.

$$\sigma_{uc} = \begin{pmatrix} \langle x^2 \rangle & \langle xx' \rangle & 0 & 0 \\ \langle x'x \rangle & \langle x'^2 \rangle & 0 & 0 \\ 0 & 0 & \langle y^2 \rangle & \langle yy' \rangle \\ 0 & 0 & \langle y'y \rangle & \langle y'^2 \rangle \end{pmatrix} \quad (6.21)$$

❖ The invariant  $W_{uc}$  is formed as before,

$$W_{uc} = \mathbf{u}^T \sigma_{uc}^{-1} \mathbf{u}$$

$$W_{uc} = \begin{pmatrix} x & x' & y & y' \end{pmatrix} \begin{pmatrix} \langle x'^2 \rangle & \langle -xx' \rangle & 0 & 0 \\ \langle -x'x \rangle & \langle x^2 \rangle & 0 & 0 \\ 0 & 0 & \langle y'^2 \rangle & \langle -yy' \rangle \\ 0 & 0 & \langle -y'y \rangle & \langle y^2 \rangle \end{pmatrix} \begin{pmatrix} x \\ x' \\ y \\ y' \end{pmatrix}$$

$$W_{uc} = \begin{pmatrix} x & x' & y & y' \end{pmatrix} \begin{pmatrix} x\langle x'^2 \rangle - x'\langle xx' \rangle \\ -x\langle xx' \rangle + x'\langle x^2 \rangle \\ y\langle y'^2 \rangle - y'\langle yy' \rangle \\ -y\langle yy' \rangle + y'\langle y^2 \rangle \end{pmatrix}$$



## *$\sigma$ -matrix for an uncoupled beam continued*

- ❖ Thus, for an uncoupled beam the invariant,  $W_{uc}$ , separates into two independent invariants,  $W_x$  and  $W_z$ .

$$W_{uc} = \underbrace{x^2 \langle x'^2 \rangle - 2xx' \langle xx' \rangle + x'^2 \langle x^2 \rangle}_{W_x} + \underbrace{y^2 \langle y'^2 \rangle - 2yy' \langle yy' \rangle + y'^2 \langle y^2 \rangle}_{W_y} \quad (6.22)$$

This can also be written as,

$$W_{uc} = \mathbf{u}^T \boldsymbol{\sigma}^{-1} \mathbf{u} = \underbrace{\mathbf{x}^T \boldsymbol{\sigma}_x^{-1} \mathbf{x}}_{W_x} + \underbrace{\mathbf{y}^T \boldsymbol{\sigma}_z^{-1} \mathbf{y}}_{W_y} \quad (6.23)$$

# Twiss and $\sigma$ -matrices

- ❖ When the beam is uncoupled, it is sufficient to consider just one transverse plane. The derived invariant for the  $x$ -plane from (6.22) is,

$$W_x = \langle x'^2 \rangle x^2 - 2\langle xx' \rangle xx' + \langle x^2 \rangle x'^2 \quad (6.22a)$$

- ❖ This is strongly reminiscent of the Courant & Snyder motion invariant defined in Lecture 1 in equation (1.16).

$$A^2 = \gamma x^2 + 2\alpha xx' + \beta x'^2 \quad (1.16)$$

- ❖ With the help of an expression called the *statistical emittance*,

$$\varepsilon_x = \pi \sqrt{\langle x^2 \rangle \langle x'^2 \rangle - \langle xx' \rangle^2} \quad (6.25)$$

the invariant  $W_x$  (6.22a) can be normalized and rewritten as,

$$\pi \frac{W_x}{\varepsilon_x} = \pi \left( x^2 \frac{\langle x'^2 \rangle}{\varepsilon_x} - 2xx' \frac{\langle xx' \rangle}{\varepsilon_x} + x'^2 \frac{\langle x^2 \rangle}{\varepsilon_x} \right)$$

## Twiss and $\sigma$ -matrices continued

- ❖ By comparison with (1.16), the Twiss functions can be defined statistically as,

$$\gamma_x = \pi \frac{\langle x'^2 \rangle}{\varepsilon_x}, \alpha_x = -\pi \frac{\langle xx' \rangle}{\varepsilon_x}, \beta_x = \pi \frac{\langle x^2 \rangle}{\varepsilon_x} \quad (6.25)$$

- ❖ It can be quickly verified that these definitions satisfy the Twiss relationship,

$$\gamma = \frac{(1 + \alpha^2)}{\beta}$$

and that the statistical emittance is equivalent to the one-sigma emittance.

- ❖ Finally, the bridge between the  $\sigma$ -matrix and the Twiss functions is completed by writing the  $\sigma$ -matrix for an uncoupled beam in terms of the Twiss functions,

$$\sigma_{uc} = \frac{1}{\pi} \begin{pmatrix} \varepsilon_x \beta_x & -\varepsilon_x \alpha_x & 0 & 0 \\ -\varepsilon_x \alpha_x & \varepsilon_x \gamma_x & 0 & 0 \\ 0 & 0 & \varepsilon_y \beta_y & -\varepsilon_y \alpha_y \\ 0 & 0 & -\varepsilon_y \alpha_y & \varepsilon_y \gamma_y \end{pmatrix} \quad (6.26)$$

**The above could be considered as an alternative derivation and definition of the Twiss parameters.**

**See also Refs [6.4] and [6.5].**

# Summary

- ❖ This introduction to machine design has covered many of the basic concepts plus some more specialized topics for the mini-workshop.
- ❖ Of course, there are still topics that we have not had time to treat: **collimation, slow resonant extraction for medical beams, space charge, non-linear resonances, stochastic and electron cooling, and so on.**
- ❖ The CD-ROM (included with these lecture notes) contains the lectures and a full-featured lattice program for the interactive design of rings and transfer lines. There is a user guide, an on-line help and some demonstration files.
- ❖ My best wishes for the rest of the course.