

Part C. Radiation shielding

1. Electron accelerators
2. Proton accelerators
3. Synchrotron radiation facilities
4. Specific:
 - a. Beam dumper
 - b. Induced Activity
 - c. RF generator plants



1. Electron accelerators

Prompt radiation fields around accelerators:

1. Electron accelerators

photons (bremsstrahlung)
neutrons

2. Proton accelerators

neutrons

3. Synchrotron radiation facilities

accelerators
beamlines



1. Electron accelerators

Examples of neutron spectra

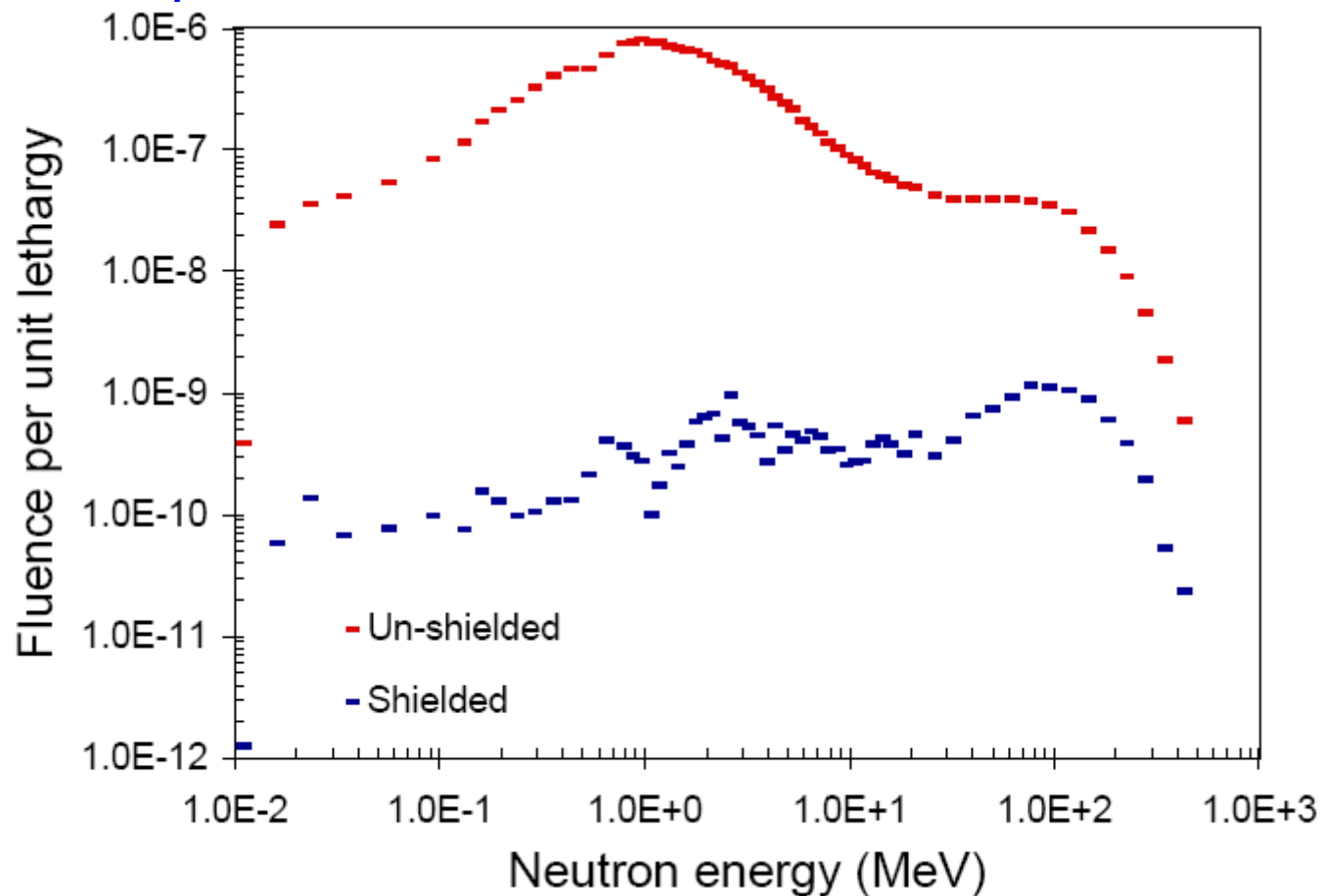

Example 1: calculated neutron spectra for the 1.7 GeV BESSY storage ring (Courtesy of Klaus Ott)



2. Proton accelerators

Examples of neutron spectra

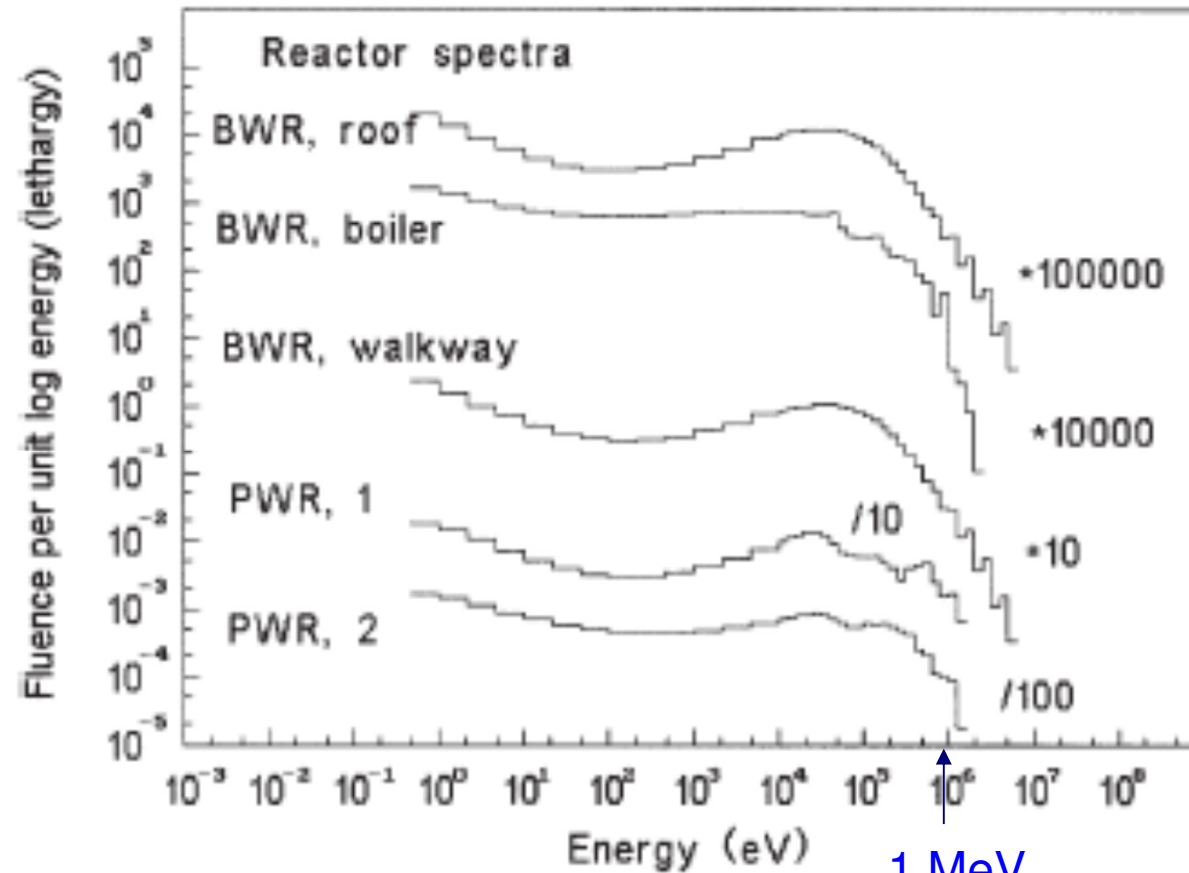

Source: Compendium of Neutron Spectra and Detector Responses for Radiation Protection Purposes – Technical Reports Series no. 403 , IAEA, 2001



2. Proton accelerators

Examples of neutron spectra

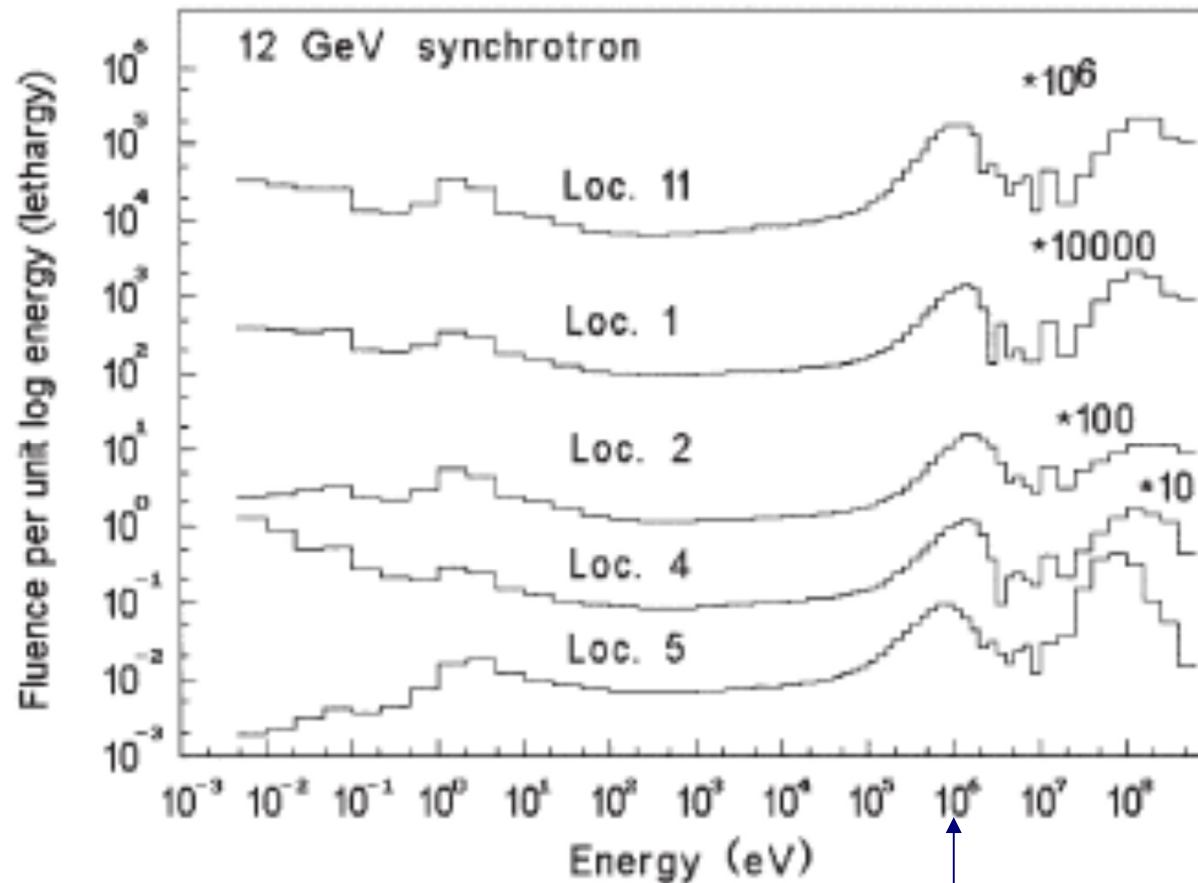

Source: Compendium of Neutron Spectra and Detector Responses for Radiation Protection Purposes – Technical Reports Series no. 403, IAEA, 2001



3. Synchrotron radiation facilities

➤ The Ott's code allows to compute the effective annual dose D , at the following directions:

- Front / Back
- Front / Side
- Inside / Outside
- Roof / Floor
- Skyshine
- Labyrinth

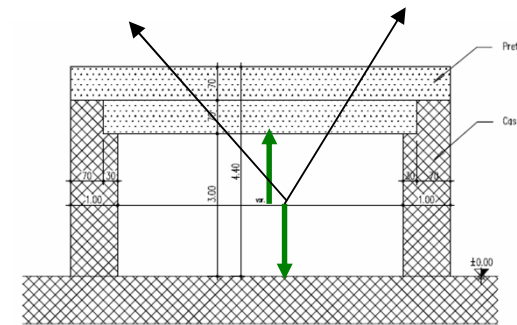
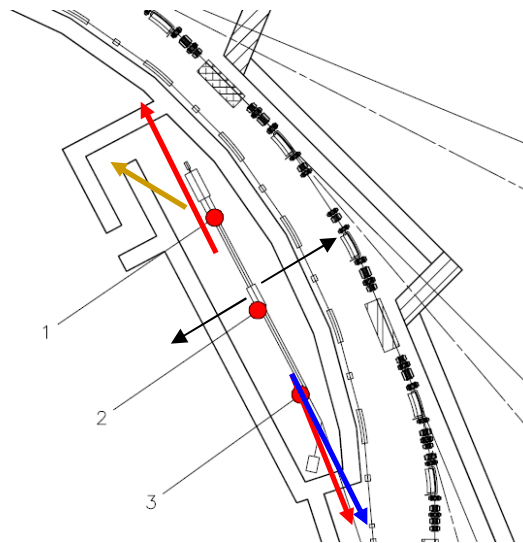

(For a given: $i_e(\vec{s})$, $t_{User}(\vec{s})$, $t_{Machine}(\vec{s})$, E_e and shielding conditions)

3. Synchrotron radiation facilities

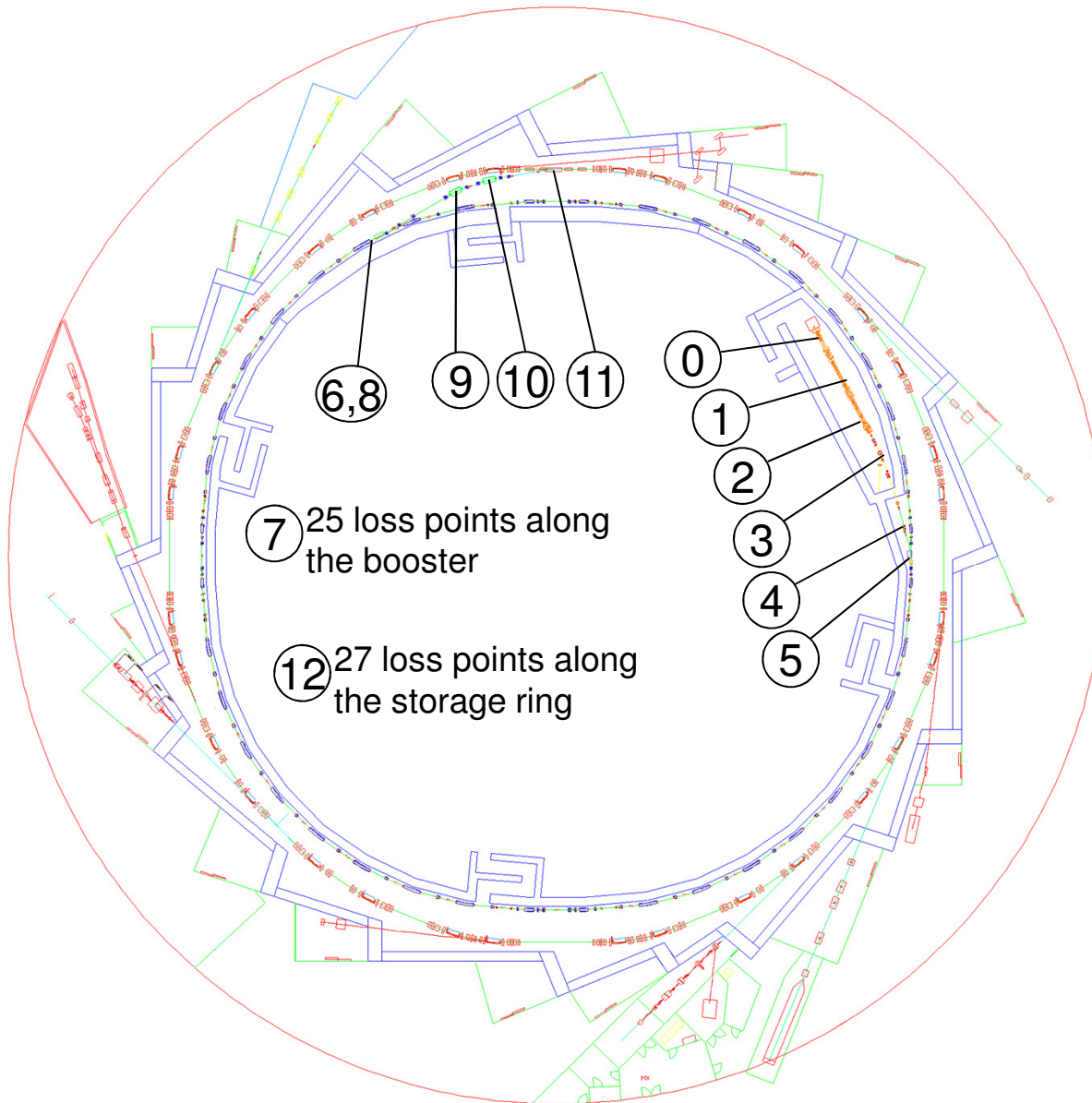

➤ e-Loss Points:

	Machine Point
0	LINAC prebuncher
1	LINAC-1
2	LINAC-2
3	Transferline LINAC->Booster
4	Transferline LINAC->Booster
5	Injection Septum
6	Extraction Septum
7	Point Sources-Booster
8	Extraction Septum
9	Transferline Booster->SR-1
10	Transferline Booster->SR-2
11	Injection Septum
12	Point Sources-Storage Ring



3. Synchrotron radiation facilities

➤ Electron losses estimation during injection:

Machine Point	% loss	Electron per second			Energy [GeV]
		LOSS	IN	OUT	
0 LINAC prebuncher	-		7.02E+10	9.24E+10	0,00009
1 LINAC-1	10%	9.24E+09	9.24E+10	8.32E+10	0,05
2 LINAC-2	10%	8.32E+09	8.32E+10	7.49E+10	0,1
3 Transferline LINAC->Booster-1	5%	3.74E+09	7.49E+10	7.11E+10	0,1
4 Transferline LINAC->Booster-2	5%	3.56E+09	7.11E+10	6.76E+10	0,1
5 Injection Septum	20%	1.35E+10	6.76E+10	3.38E+10	0,1 to 3
6 Extraction Septum	15%	1.01E+10	3.38E+10	3.38E+10	0,1 to 3
7 Point Sources-Booster	15%	1.01E+10	3.38E+10	3.38E+10	0,1 to 3
8 Extraction Septum	15%	5.07E+09	3.38E+10	2.87E+10	3
9 Transferline Booster->SR-1	5%	1.44E+09	2.87E+10	2.73E+10	3
10 Transferline Booster->SR-2	5%	1.36E+09	2.73E+10	2.59E+10	3
11 Injection Septum	40%	6.48E+09	2.59E+10	1.30E+10	3
12 Point Sources-Storage Ring	30%	6.48E+09	1.30E+10	1.30E+10	3

3. Synchrotron radiation facilities

- Operation time, depending on the machine mode:

User mode

Operating time /day	24 hours
Operating time/year (250 days/year)	6000 hours
Storage time /filling	5 hours
Injections / day	5
Injections / year	1200
Booster operation / injection	12 minutes
Booster operation / year	250 hours
Min. injection time/ injection	169 seconds
Min. injection time/ year	59 hours
Max. injection time/ injection	507 seconds
Max. injection time/ year	176 hours

Machine Test mode

Machine test weeks / year	12 hours
Injections / day	10 hours
Injections / year	600 hours
Synchrotron operation / injection	48 minutes
Synchrotron operation / year	476 hours
Min. injection time / injection	169 seconds
Min. injection time / year	28 hours
Max. injection time / injection	2535 seconds
Max. injection time / year	422 hours

- The dose limit objective at ALBA (following the ALARA principle) is **1 mSv/a** in all the site



3. Synchrotron radiation facilities

➤ Annual Dose:

$$D = \sum_{i=1}^3 D_i = D_{\gamma\text{-ray}} + D_{\text{giant-neutron}} + D_{\text{fast-neutron}}$$

Where D_i is given by:

$$D_i(\vec{s}) = i_e(s) \cdot t(s) \cdot H_i(\vec{s})$$

\vec{s} : accelerator point

$i_e(s)$: is the electron loss rate at s-point

$t(s) = t_{\text{User}}(s) + t_{\text{Machine}}(s)$: is the time that the e-loss occurs (at s-point)

$H_i(\vec{s})$: is the dose rate (at s-point) for i-particle



3. Synchrotron radiation facilities

➤ Shielding Scheme Drawing:

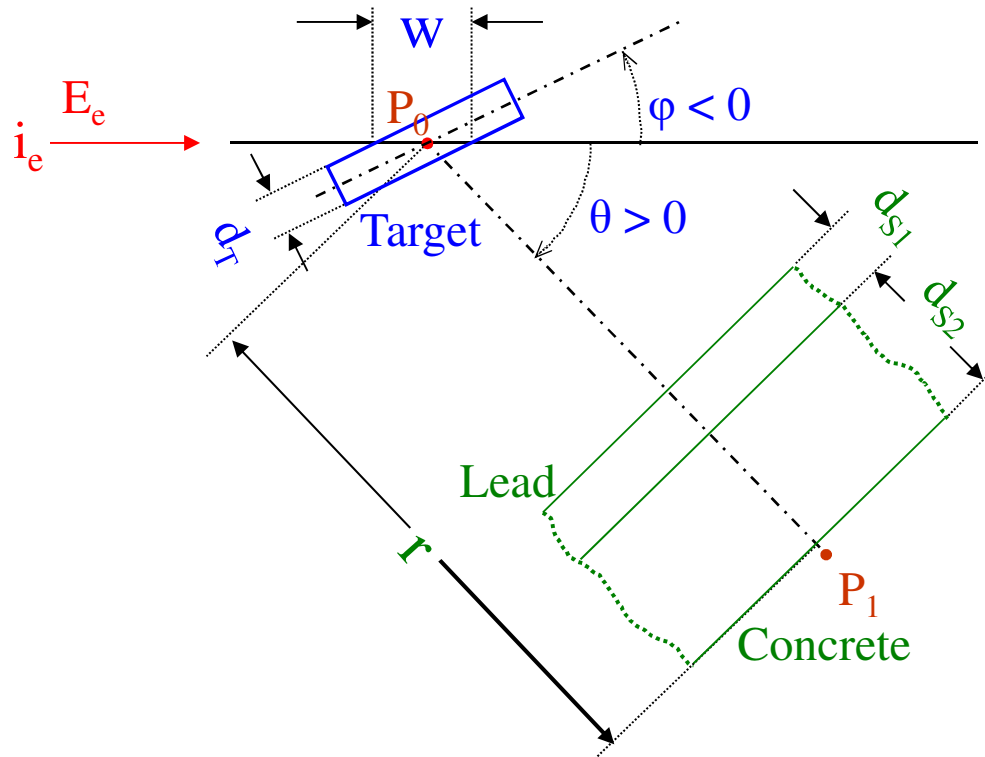

➤ In the ALBA case:

Source (for the Storage Ring):

$i_e = 400 \text{ mA}$

$E_e = 3.0 \text{ GeV}$

Target:

$d_T [\text{cm}]$: depends on the machine point

φ : depends on the machine point

$\rho_T [\text{g/cm}^3]$: stain steel

Shielding:

$r [\text{cm}]$: depends on the machine point

$\rho_{S1} [\text{g/cm}^3]$: lead

$d_{S1} = 5 \text{ cm}$

$\rho_{S2} [\text{g/cm}^3]$: concrete (normal & heavy)

$d_{S2} = 1 \text{ m}$ (side) & 1.5 m (front) & 1.4 m (roof)

Θ : depends on machine point

➤ Dose at P_1 , (per incident electron at P_0):

$$H = H(E_e; w(d_T, \varphi), \rho_T; r, \rho_{S1}, d_{S1}, \rho_{S2}, d_{S2}, \theta)$$

3. Synchrotron radiation facilities

Analytical model (for photons):

$$\dot{H}_p = \sum_i \frac{\dot{H}_0 \times e\left[-\left(\mu/\rho\right)_i \rho_i \times d\right]}{r_p^2}$$

\dot{H}_p : Dose rate equivalent rate (in Sv/h) in a given point-p, out of the shielding area

\dot{H}_0 : Dose rate equivalent rate (in Sv/h) at 1 m from the source, without the shielding

d : Shield thickness (in cm)

$(\mu/\rho)_i$: mass attenuation coefficient (in cm^{-1}) for the material-i

r_p : distance from the source point to the dose point-p (in m)

i : sum over different materials



3. Synchrotron radiation facilities

Example (in air): a 1 Sv/h (at 1 meter in vacuum) 100 keV photon source, at 10 m?

$$\dot{H}_p = \frac{1 \times e^{[-(0.1541 \times 0.00123) \times 1000]}}{10^2} = 8.3 \text{ mSv/h}$$

Buildup factor effect: how the shielding ‘unshield’ the source



3. Synchrotron radiation facilities

Monte-Carlo codes

- Examples: MCNPX
PENELOPE
FLUKA
MARS

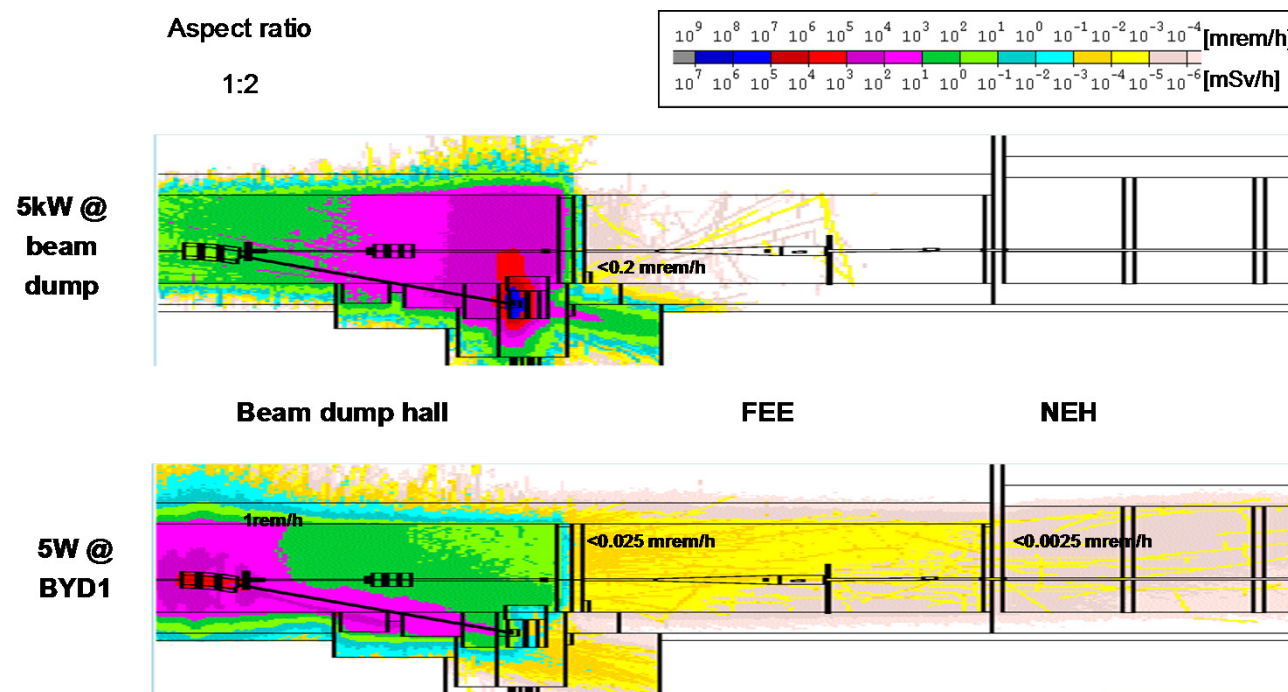

Example: MARS calculation for the electron dump line of the LCLS facility - Courtesy of T. Sanami.

3. Synchrotron radiation facilities

➤ Concrete structures:

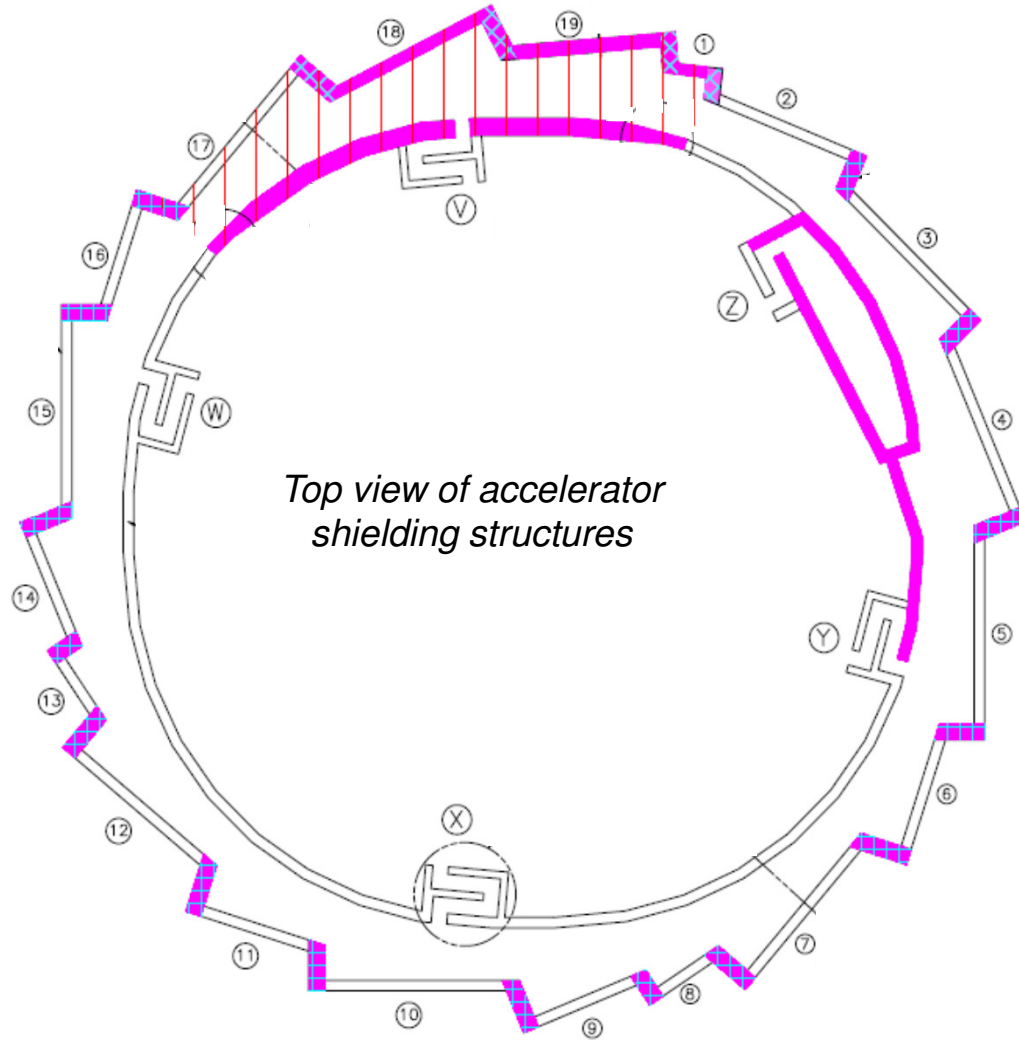

Inner and side walls thickness	1 m
Inner wall thickness at injection	1.65 m
Side wall thickness at injection	1.25 m
Roof thickness	1 m
Roof thickness at injection	1.4 m
Linac walls thickness	1 m
Labyrinths walls thickness	0.7 m
Front walls thickness	1.5 m
Number of side/front walls	19
Concrete density	2.4 g/cm ³
Heavy concrete density	3.2 g/cm ³

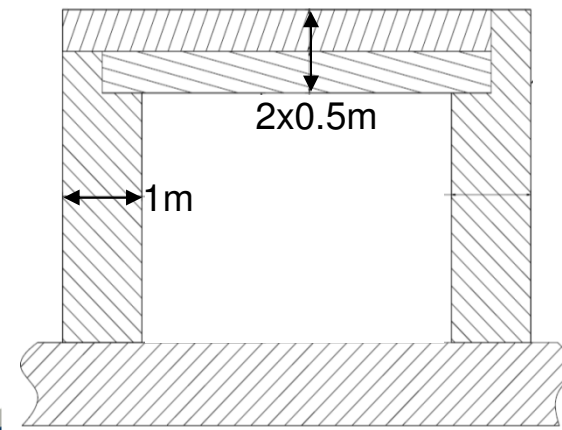

3. Synchrotron radiation facilities

➤ Front wall: final option

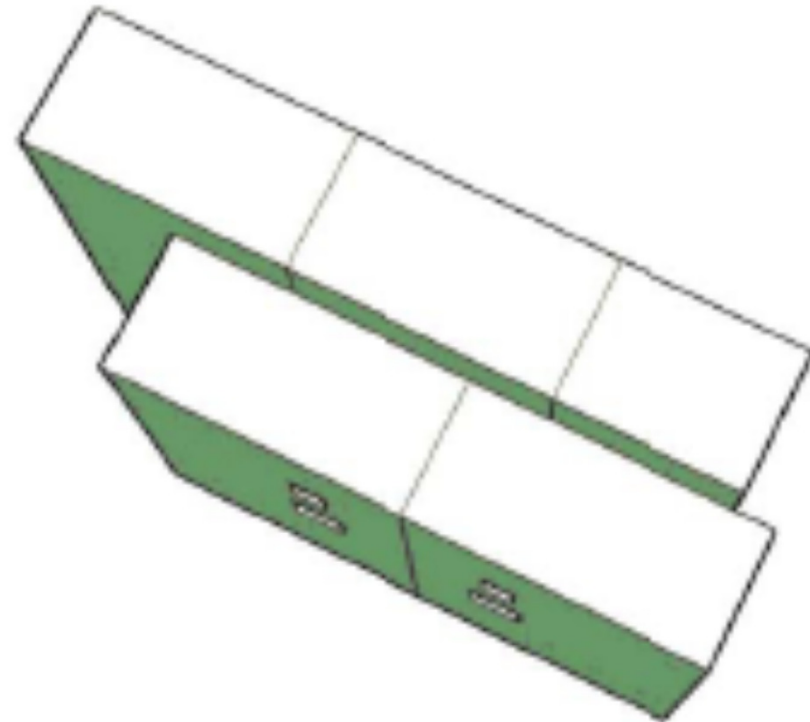
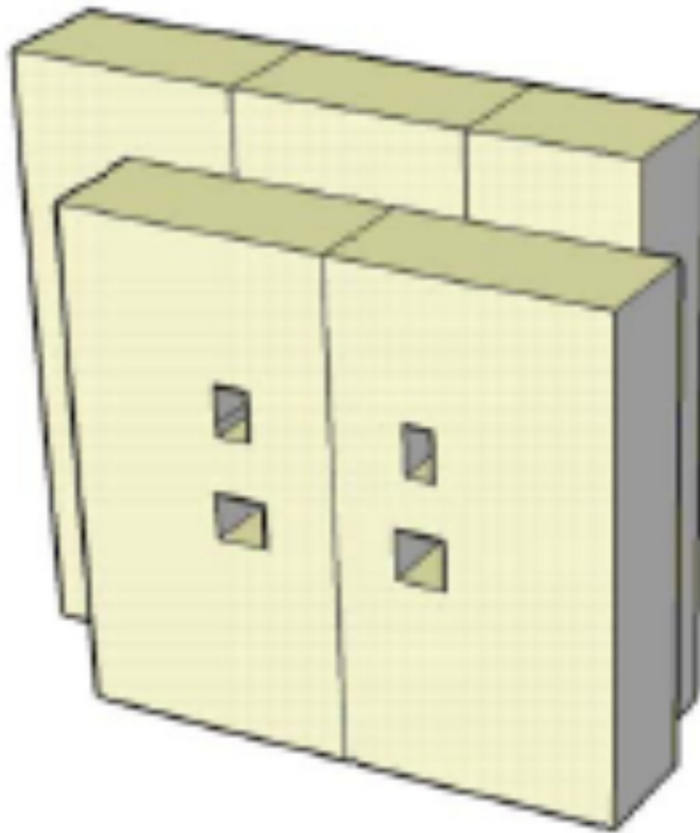

3. Synchrotron radiation facilities



➤ Most critical areas

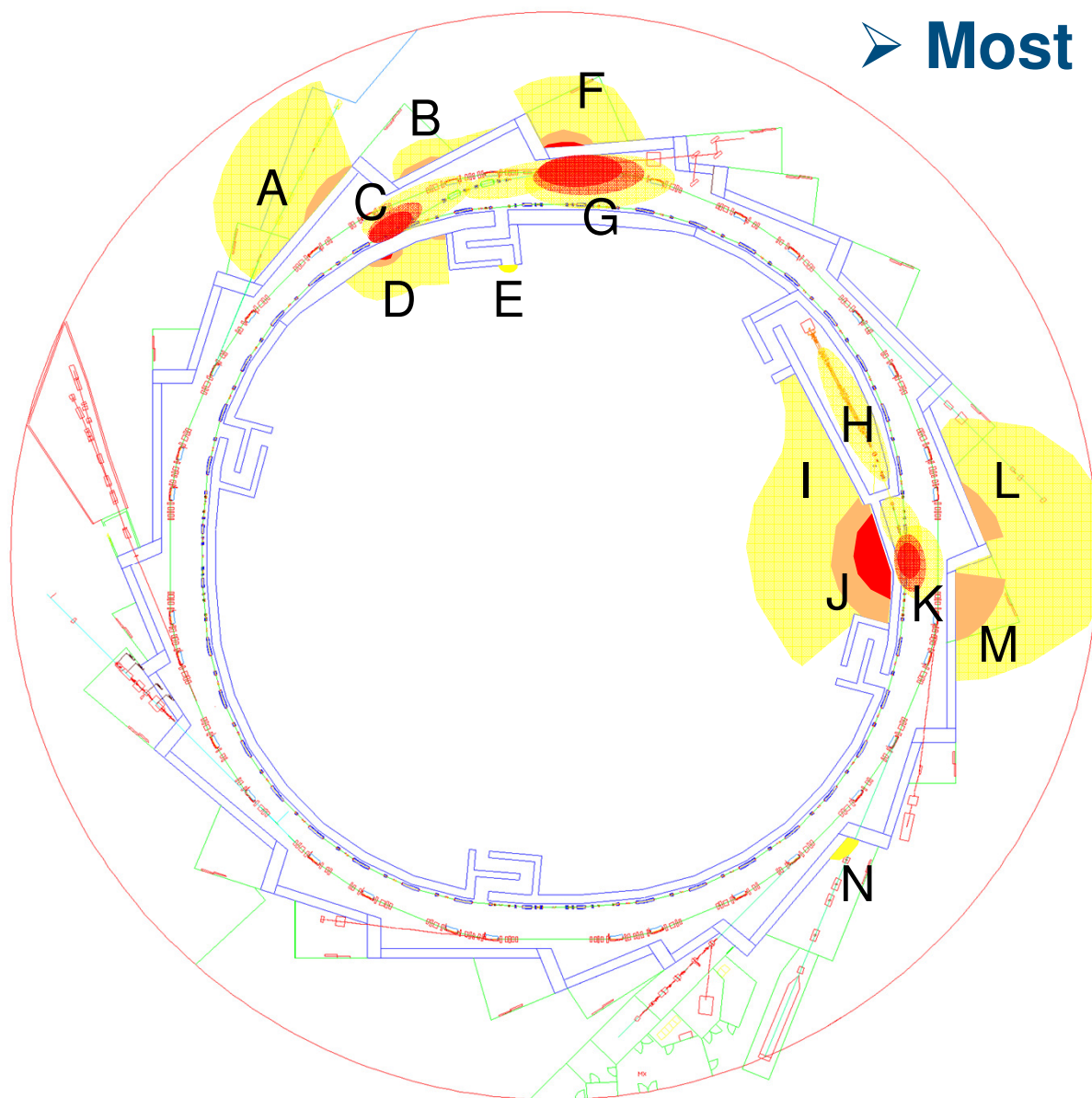

- 0.1-0.5 mSv/y
- 0.5-1.0 mSv/y
- >1.0 mSv/y



3. Synchrotron radiation facilities

3. EL SINCROTRÓ ALBA: LES LÍNIES EXPERIMENTALS



3. Synchrotron radiation facilities

Radiation fields

Accelerator tunnels:

photons, neutrons

Beamlines:

X-rays, photons, neutrons

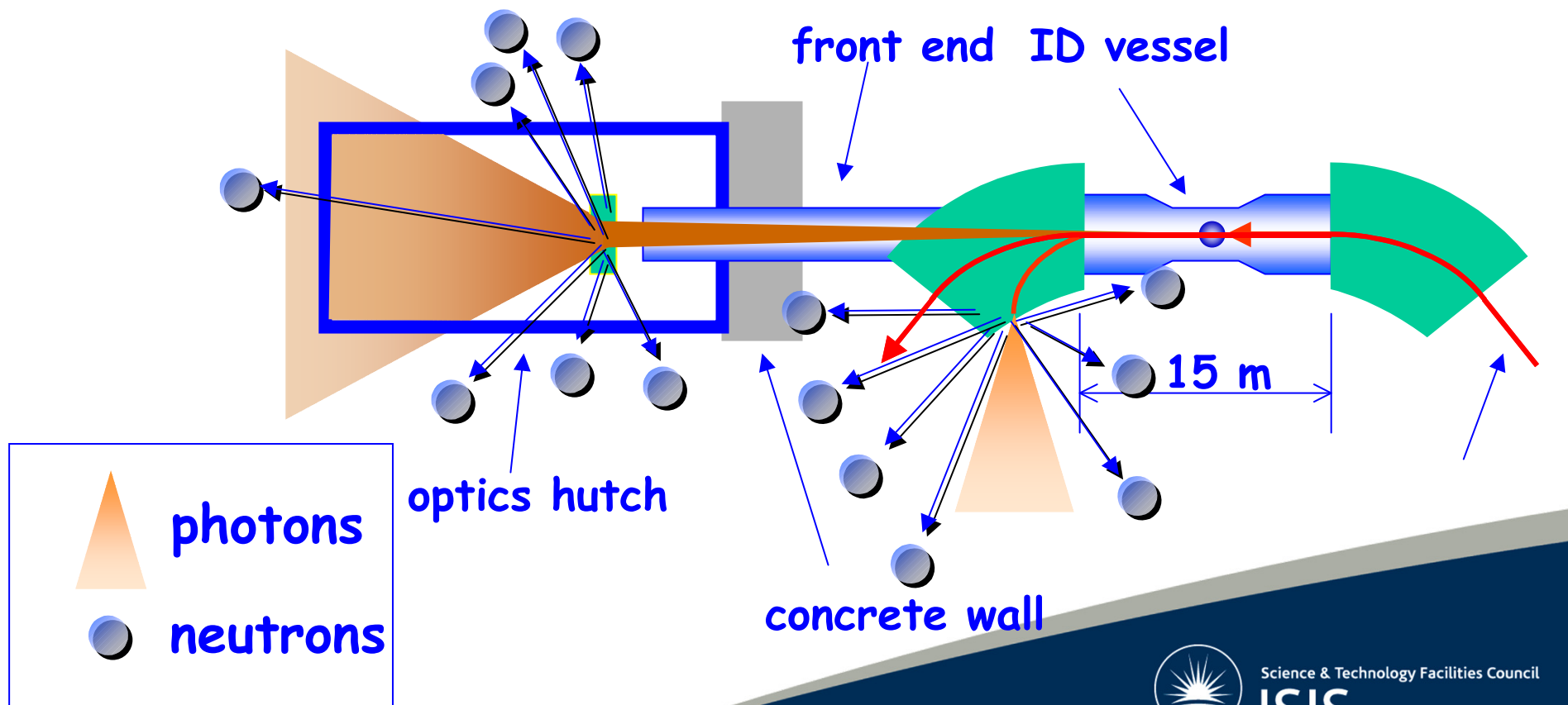

3. Synchrotron radiation facilities

2. BEAMLINES SHIELDING - SOURCE TERM

➤ Gas bremsstrahlung:

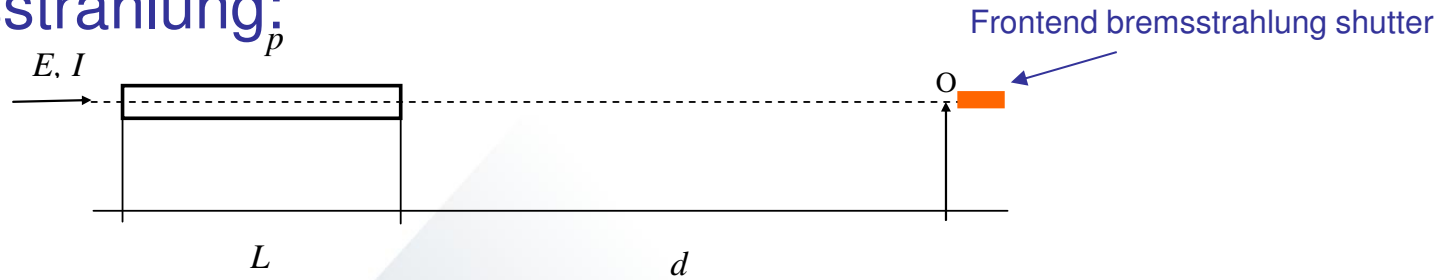

$$\dot{D}_0 = 2.5 \times 10^{-27} \cdot \left(\frac{E}{mc^2} \right)^{2.67} \cdot \frac{L}{d(L+d)} \cdot I \cdot \frac{p}{p_0}$$

\dot{D}_0 : is the dose rate at O-point (Energy/Mass/Time)

✓ If:

- L = 4 m ; d = 18 m
- I = 400 mA
- P = 1.4 10⁻⁹ mbar

$$\dot{D}_0 = 0.6 \text{ Gy/h}$$

$$\frac{\dot{D}_0 \Big|_{3 \text{ GeV}}}{\dot{D}_0 \Big|_{2 \text{ GeV}}} = \frac{3^{2.67}}{2^{2.67}} \approx 3$$

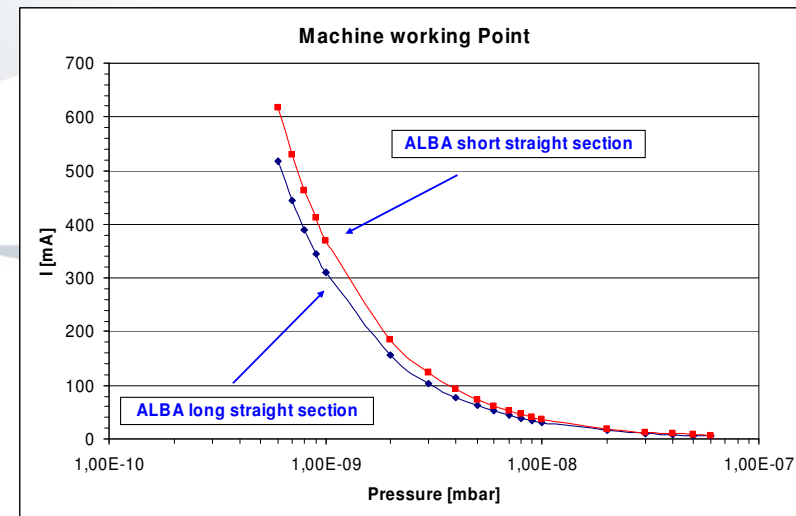

✓ Strong dependence with the machine condition (E, I and P)

3. Synchrotron radiation facilities

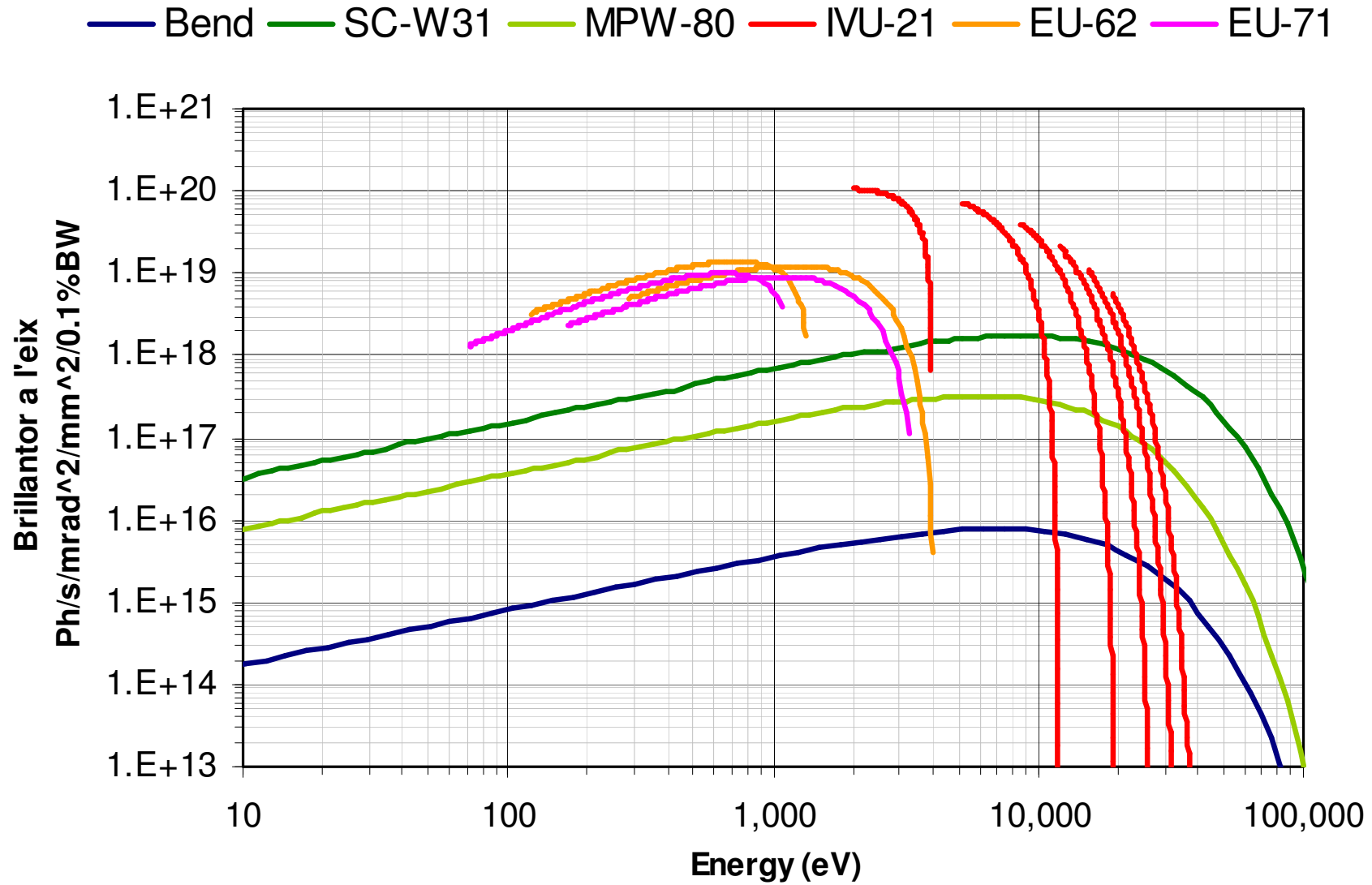

3. Synchrotron radiation facilities

❖ Source term

✓ Internal rules:

1 mSv / year

0.5 μ Sv / h

(2000 hour / year)

✓ Order of the radiation source term

1 Sv / h

> 10^6 times reduction

✓ Shielding elements required:

- Hutch walls
- Stopper & Shutter



3. Synchrotron radiation facilities

2. BEAMLINES SHIELDING - SAFETY ELEMENTS

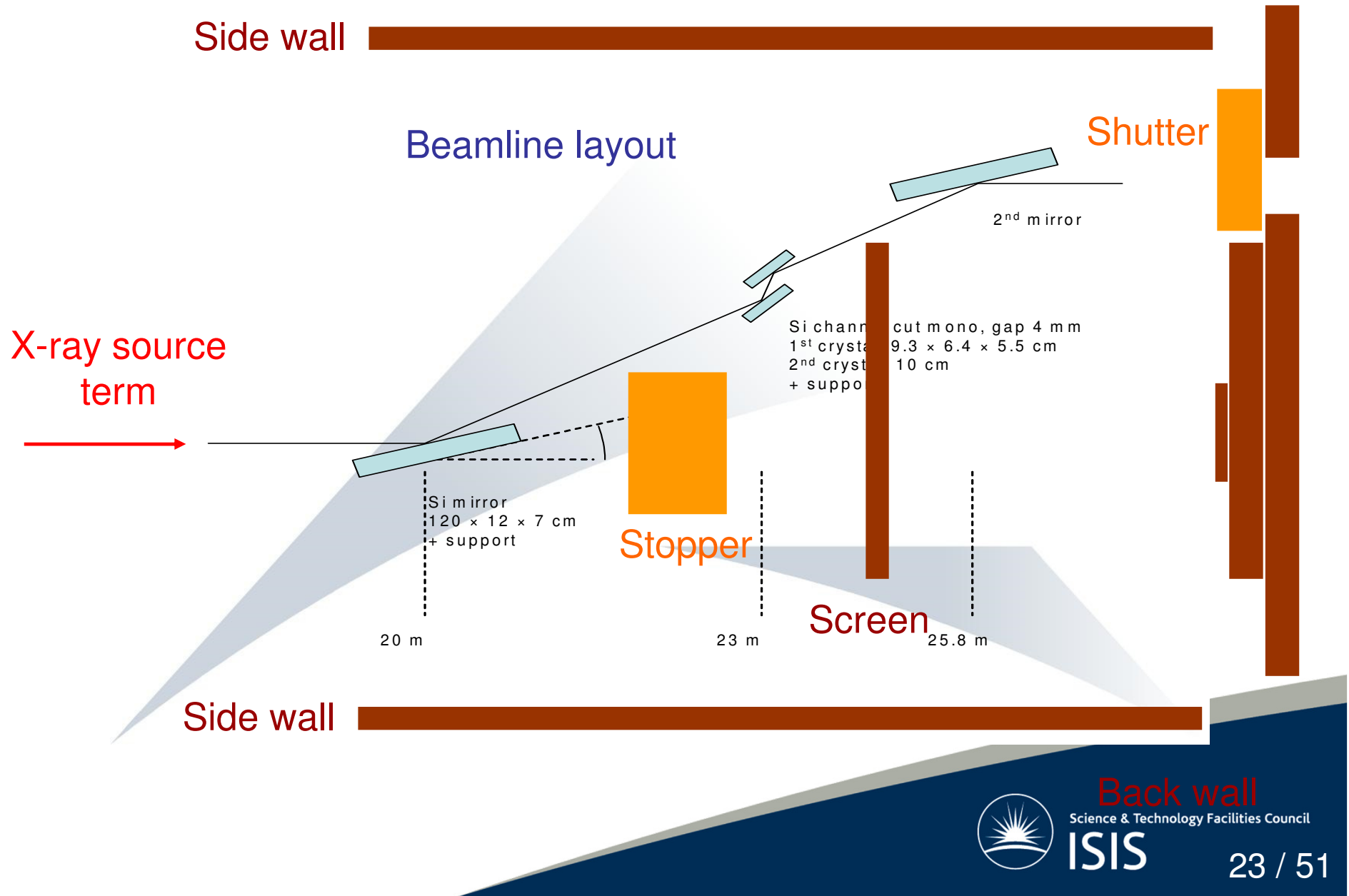

3. Synchrotron radiation facilities

2. BEAMLINES SHIELDING - SAFETY ELEMENTS

❖ Shielding against gas bremsstrahlung

➤ Backwall thickness (for the HRPD case):

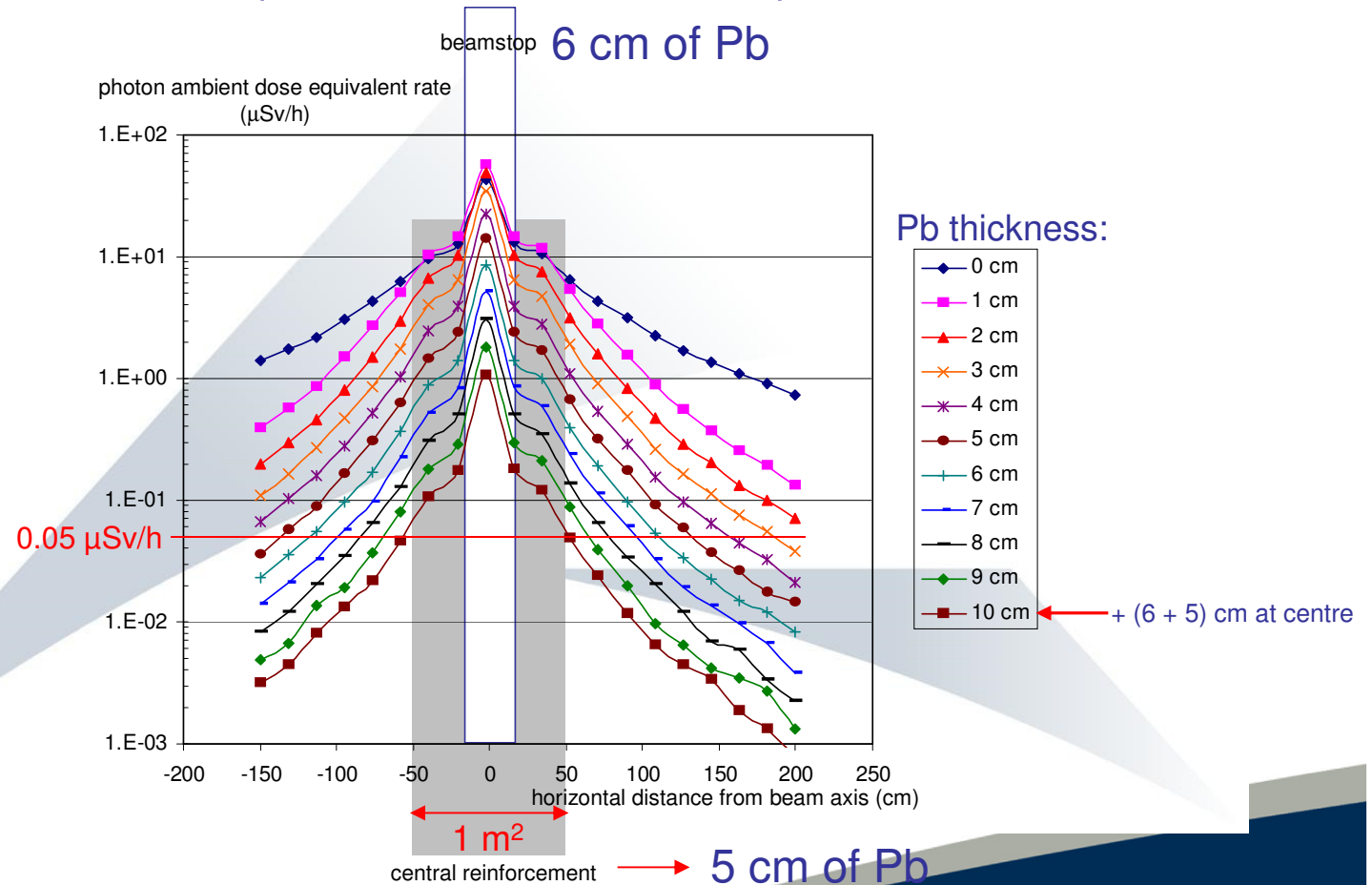

4a. Beam dumper

LINAC BUNKER – Baritated concrete 3.2g/cm^3 1 m thick

LINAC TRENCHES

ALBA TUNNEL

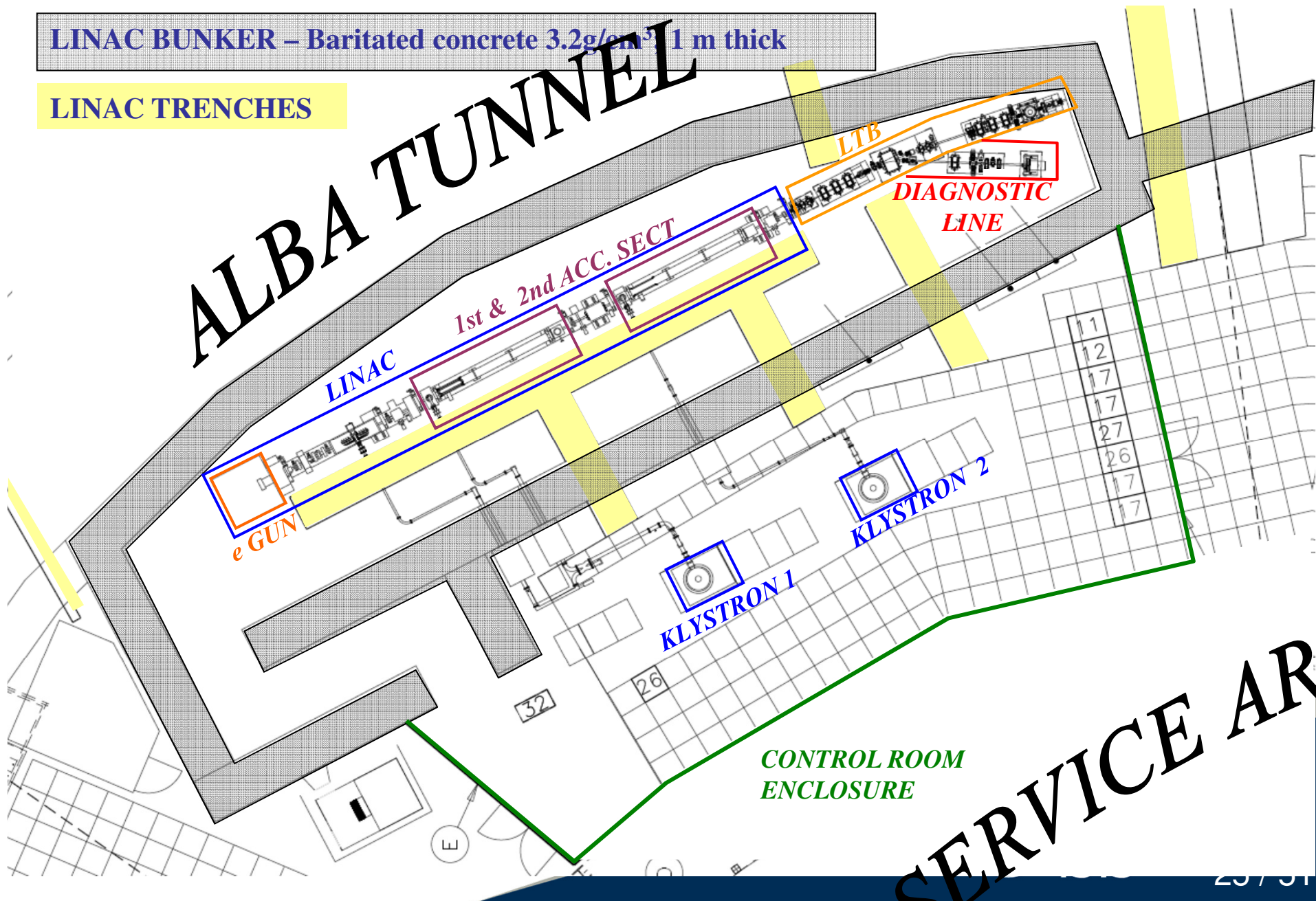

4a. Beam dumper

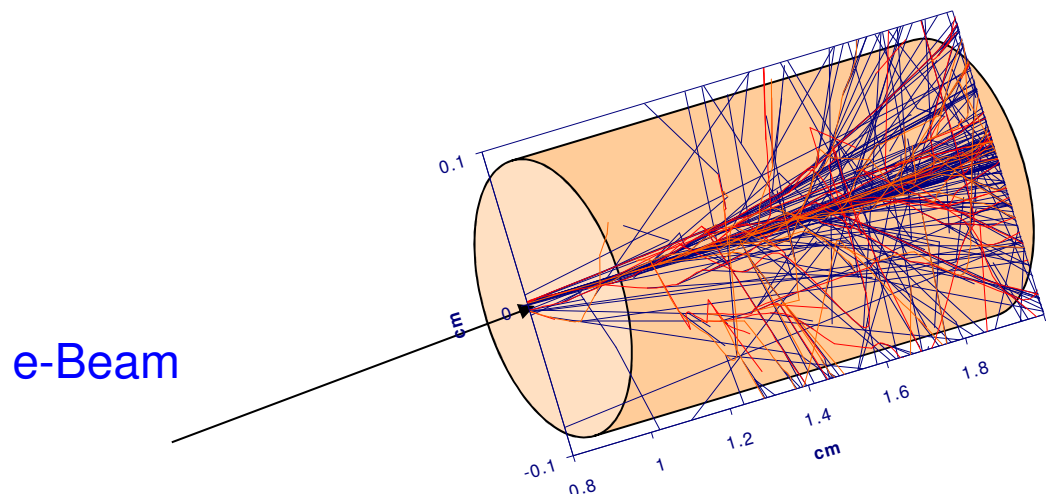

Molière radius (ρ_M): it is the radius of a cylinder containing on average 90% of the shower's energy deposition.

$$\rho_M [\text{cm}] = 0.0265 [\text{cm}^3/\text{g}] X_0 (Z + 1.2)$$

Where:

X_0 [g/cm^2]: Radiation length (for Cu: 12.86 g/cm^2)

Z: atomic number (for Cu: 29)

$\rho_M = 10.29 \text{ cm}$



4a. Beam dumper

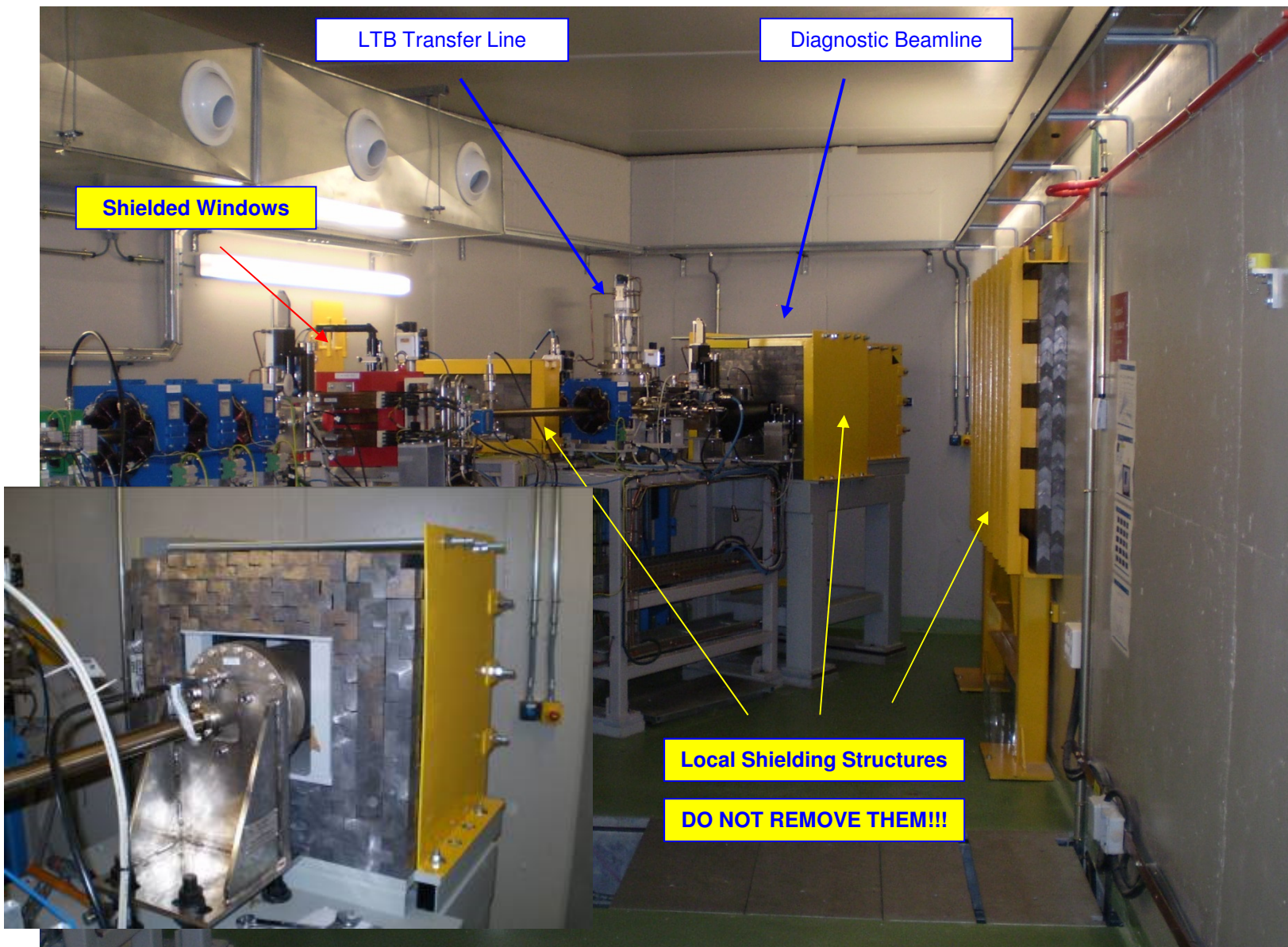

4b. Induced Activity

- radiation remains after accelerator switched off
- work permits for people entering tunnels
- radiation protection: personnel and environment
- management of activated accelerator components
- decommissioning of facilities

- thermal and slow neutron reactions
- medium energy neutron reactions
- nuclear reactions at high energy (spallation)
- photonuclear reactions

relatively insensitive to activation	moderately susceptible to activation	highly susceptible to activation	fissionable
ordinary concrete, Pb, Al, wood, plastics	Fe (steel, ferrites), Cu	Stainless steel, W, Ta, Zn, Au, Mn, Co, Ni	U, Pu, Th



4b. Induced Activity

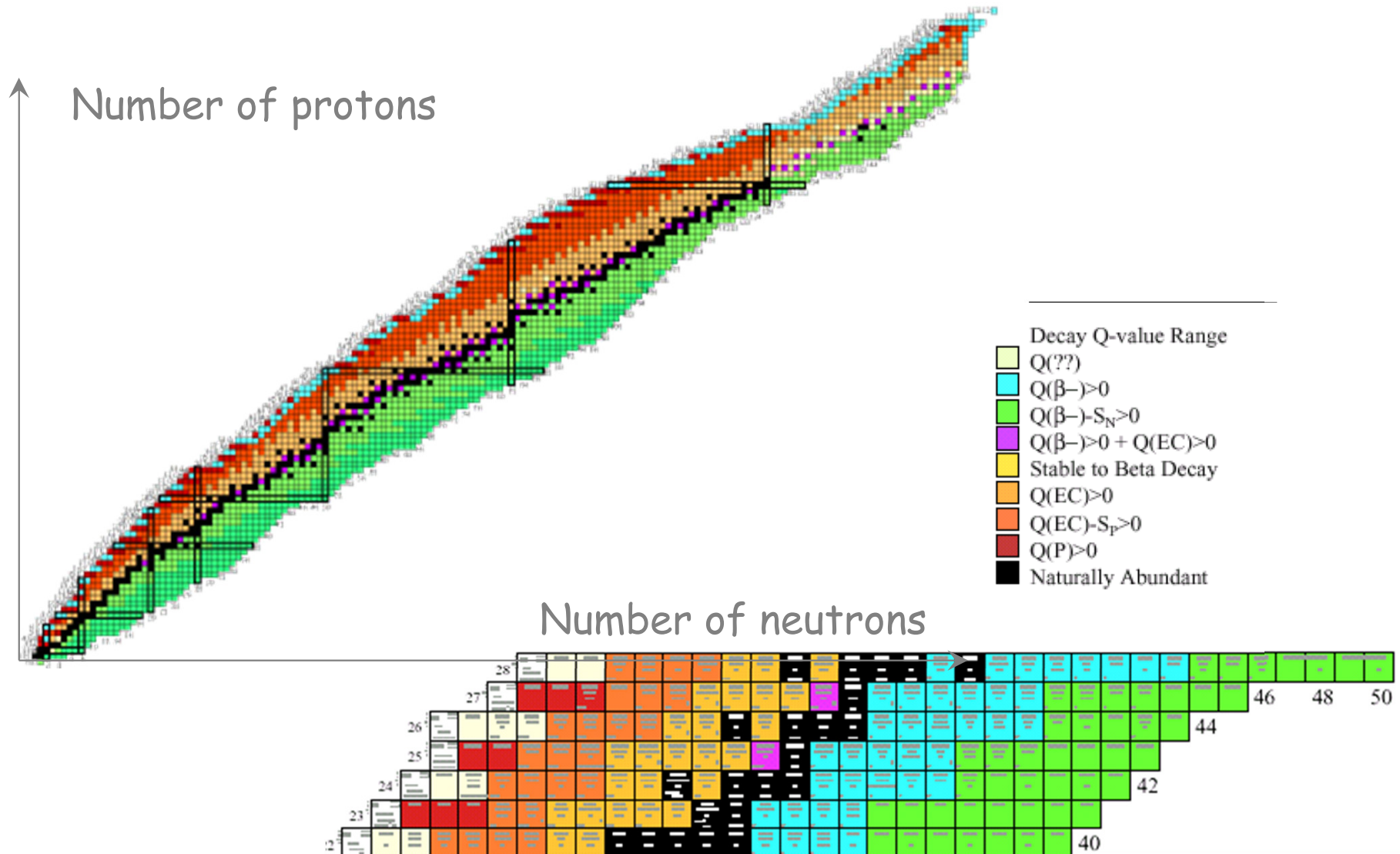

4b. Induced Activity

Activation from electron beam

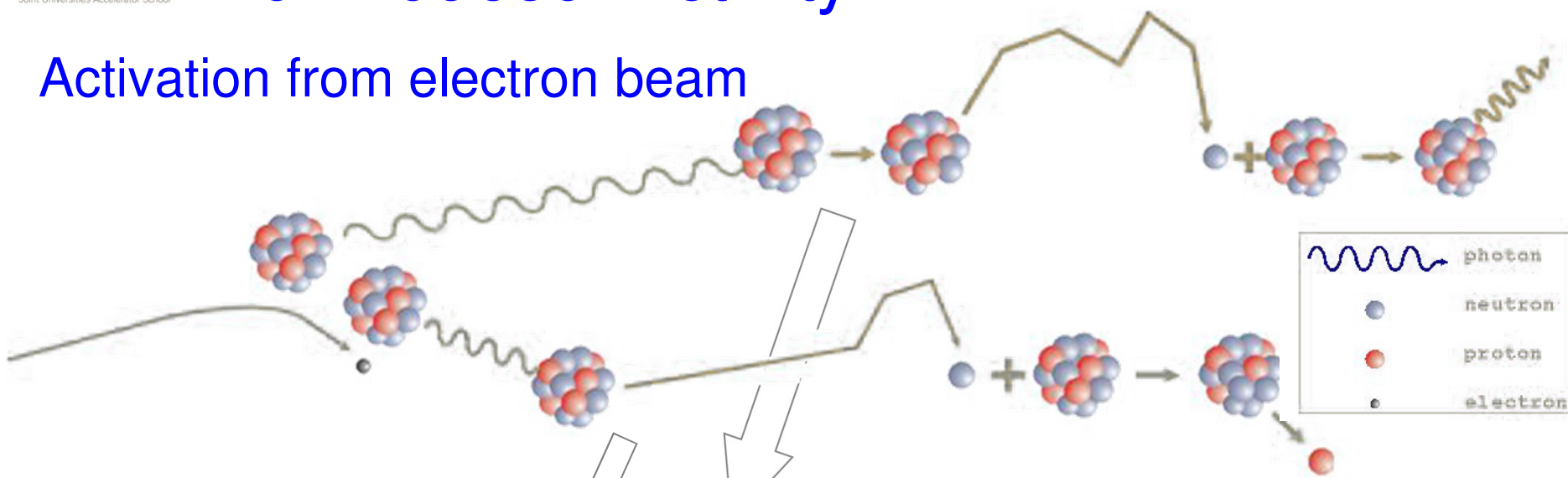

photonuclear reactions
(γ, n), (γ, p), (γ, np), ...

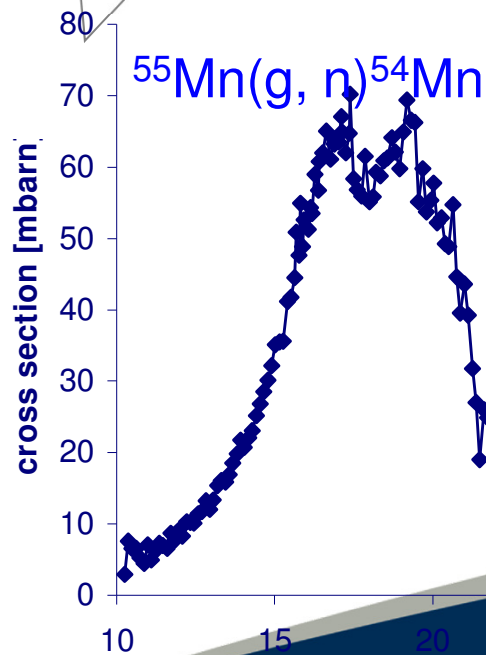
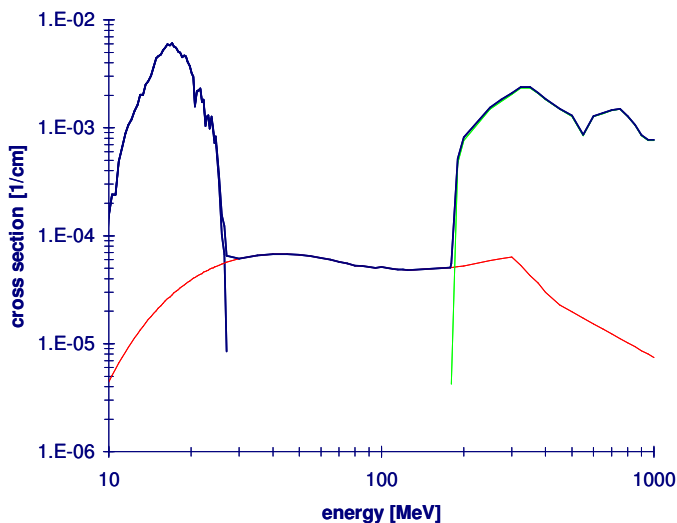

4b. Induced Activity

Activation from electron beam

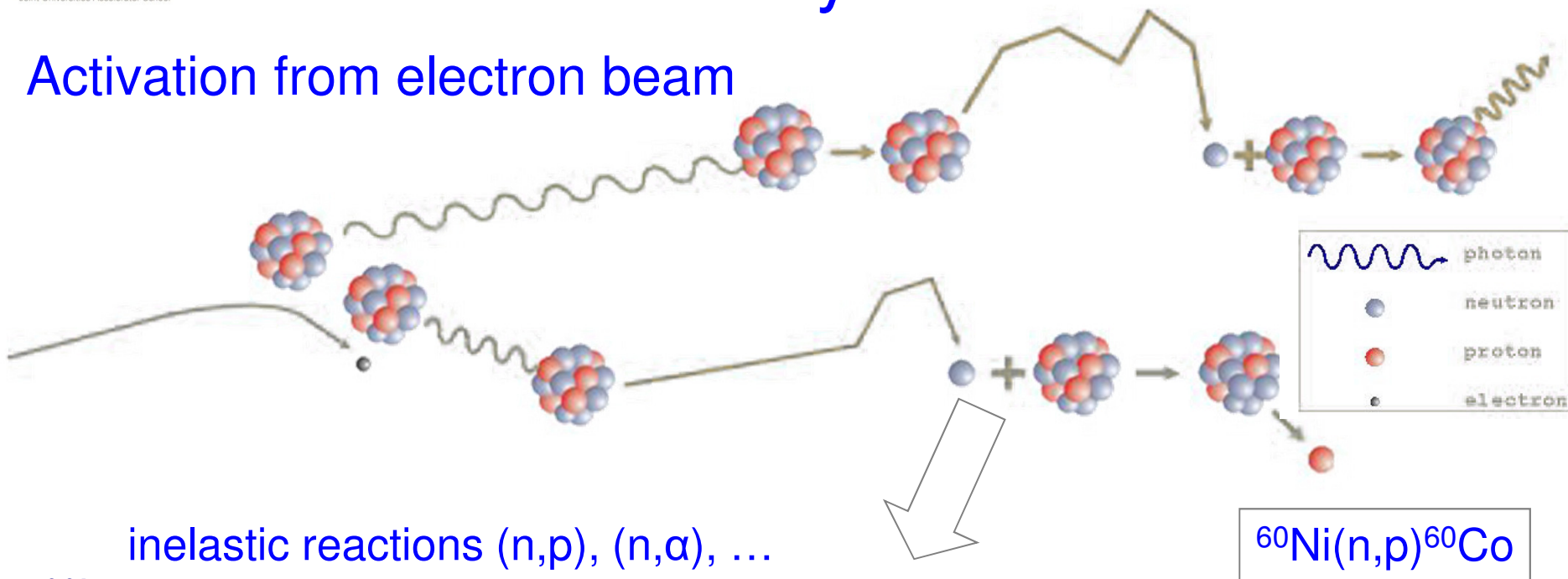

inelastic reactions (n,p), (n, α), ...

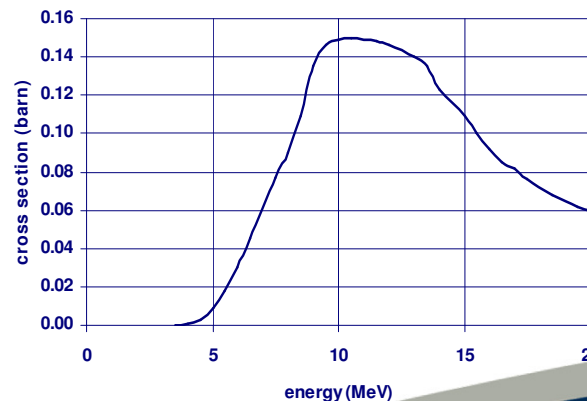
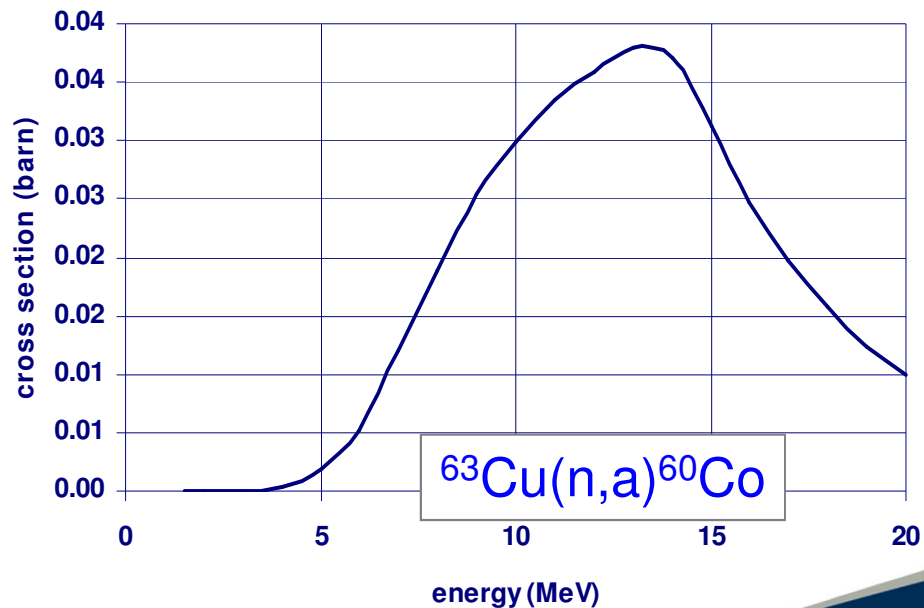

4b. Induced Activity

Activation from electron beam

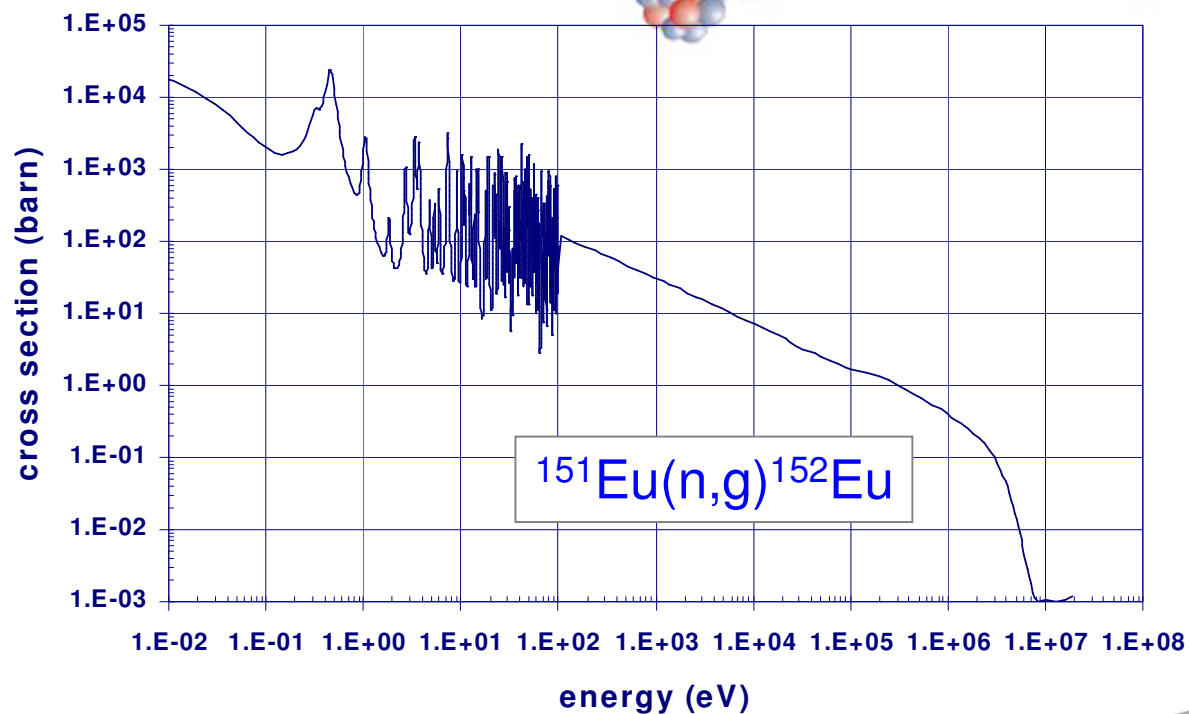
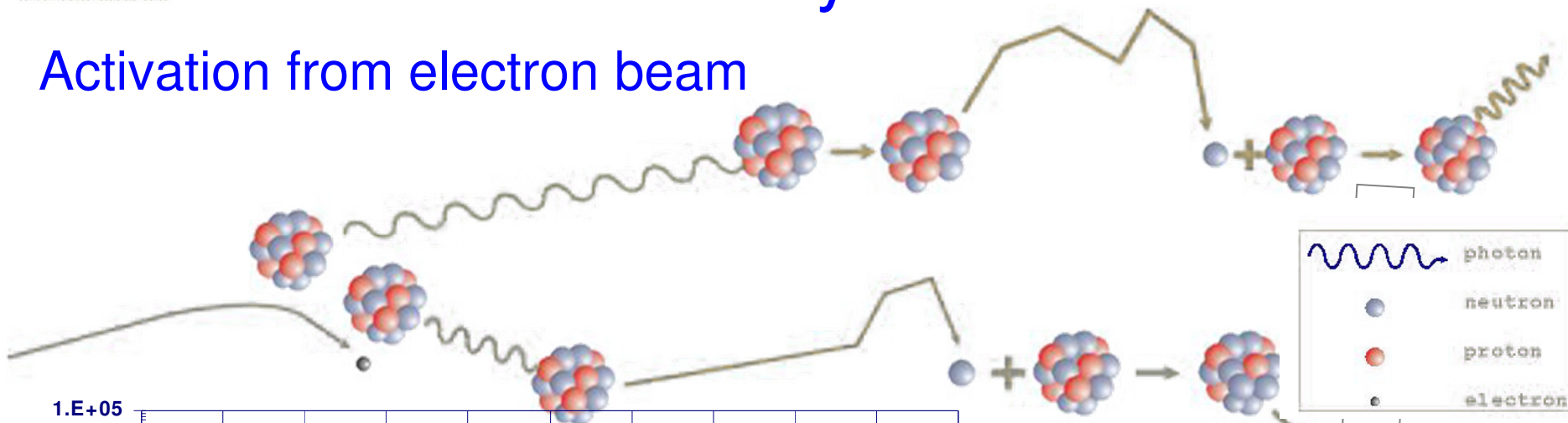

Radioactive capture

4b. Induced Activity

Activation from electron beam

Example: cooling down curve of irradiated steel

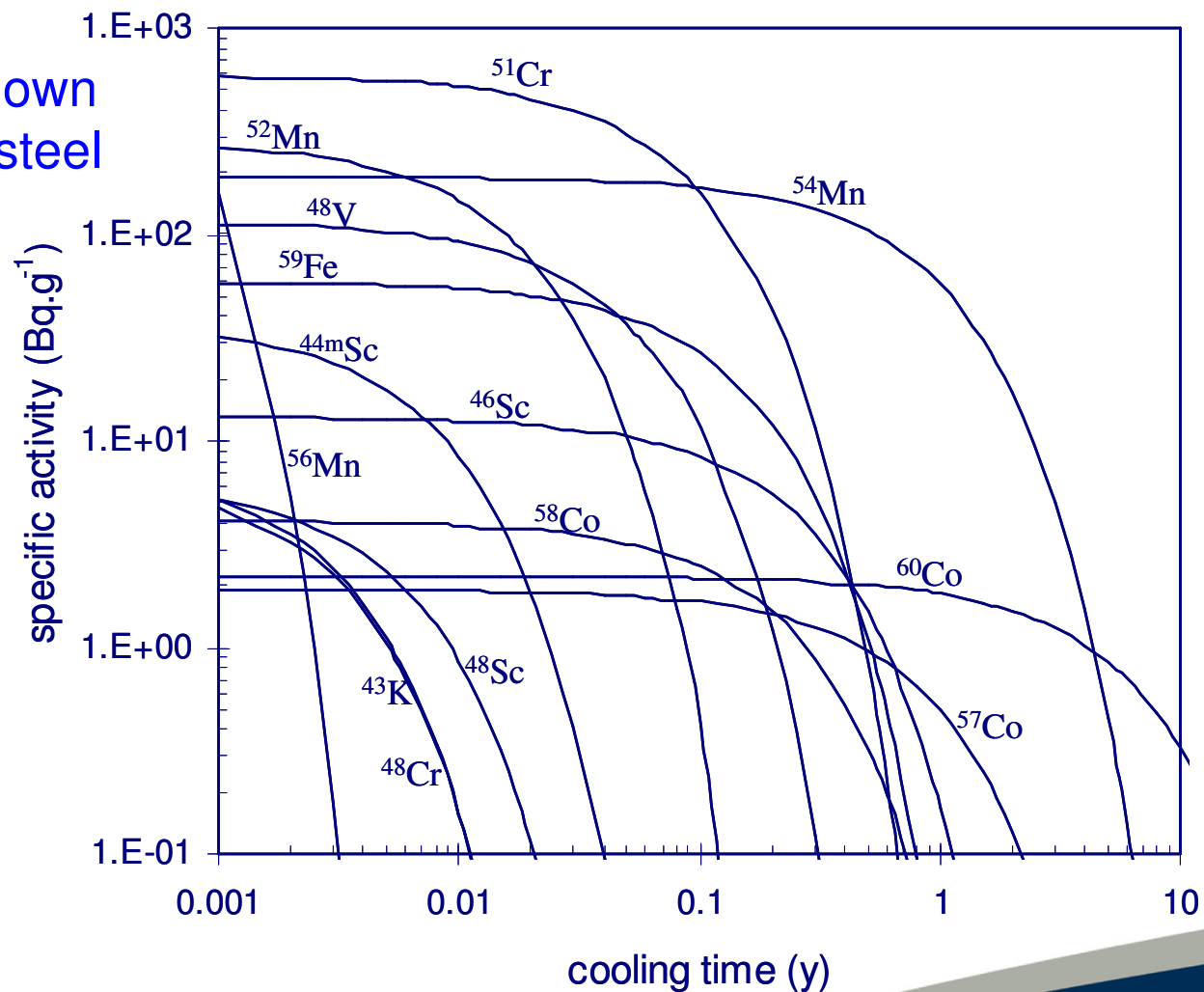

4b. Interaction of protons with matter

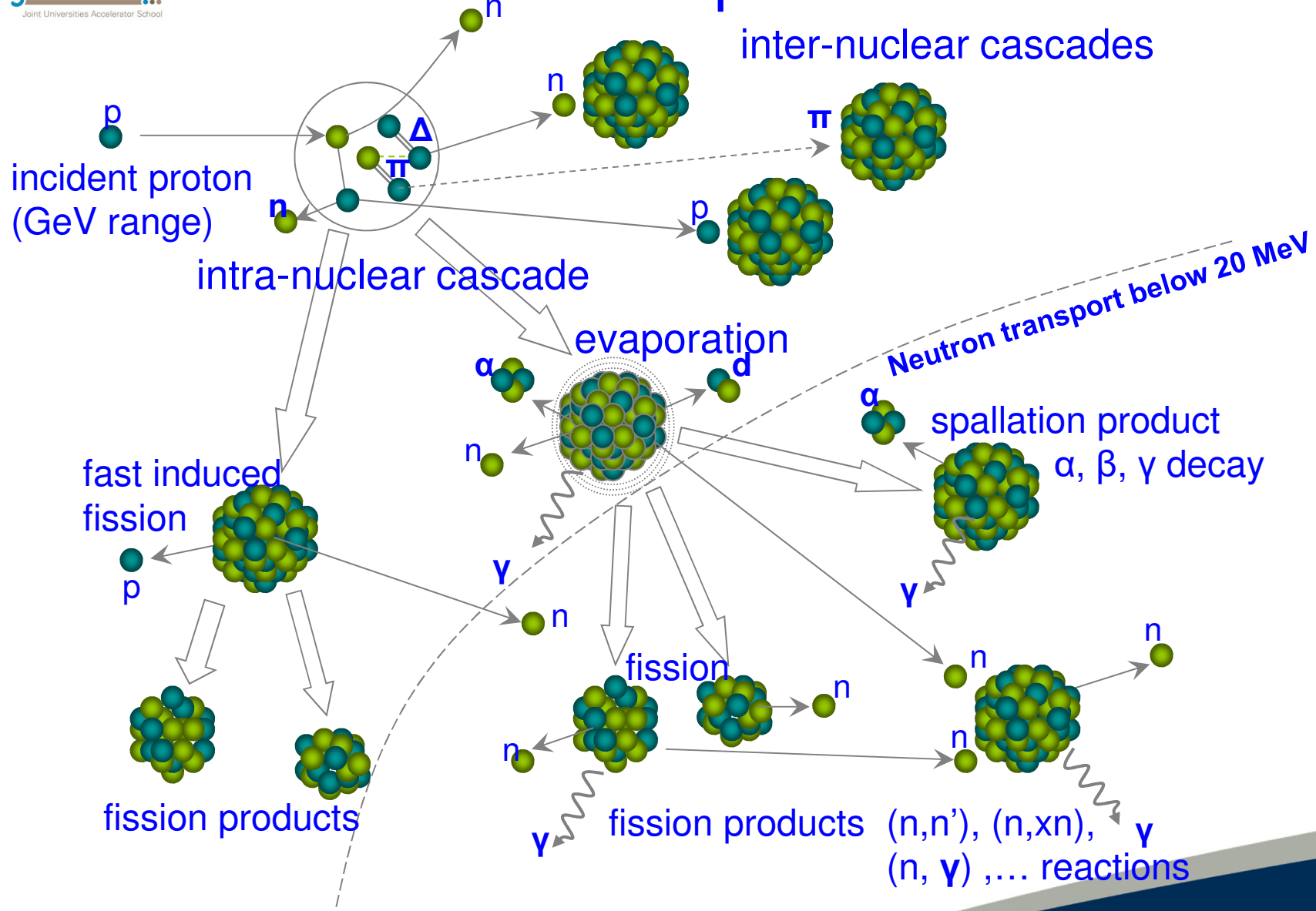

Activation from proton beam



4b. Induced Activity

Activation from proton beam

Isotope	Half-life	Decay mode	fSv.h ⁻¹ .Bq ⁻¹ at 1 m
⁷ Be	53 d	EC	7.8
¹¹ C	20 min	β ⁺	140
¹⁸ F	1.8 h	β ⁺	132
²² Na	2.6 y	β ⁺	298
²⁴ Na	15 h	β ⁺	560
⁴⁶ Sc	84 d	β ⁺	283
⁴⁸ Sc	1.8 d	β ⁺	455
⁴⁸ V	16 d	β ⁺	397
⁵¹ Cr	28 d	EC	4.3
⁵² Mn	5.7 d	β ⁺	326
⁵⁴ Mn	303 d	EC	114
⁵⁶ Co	77 d	β ⁺	350
⁶⁰ Co	5.3 y	β ⁺	340
⁶⁵ Zn	245 d	EC	76

Principal radioactive isotopes
produced in accelerator structures
by spallation reactions



4b. Particular case: $^{60}\text{Co} = ^{60}_{27}\text{Co}_{33}$

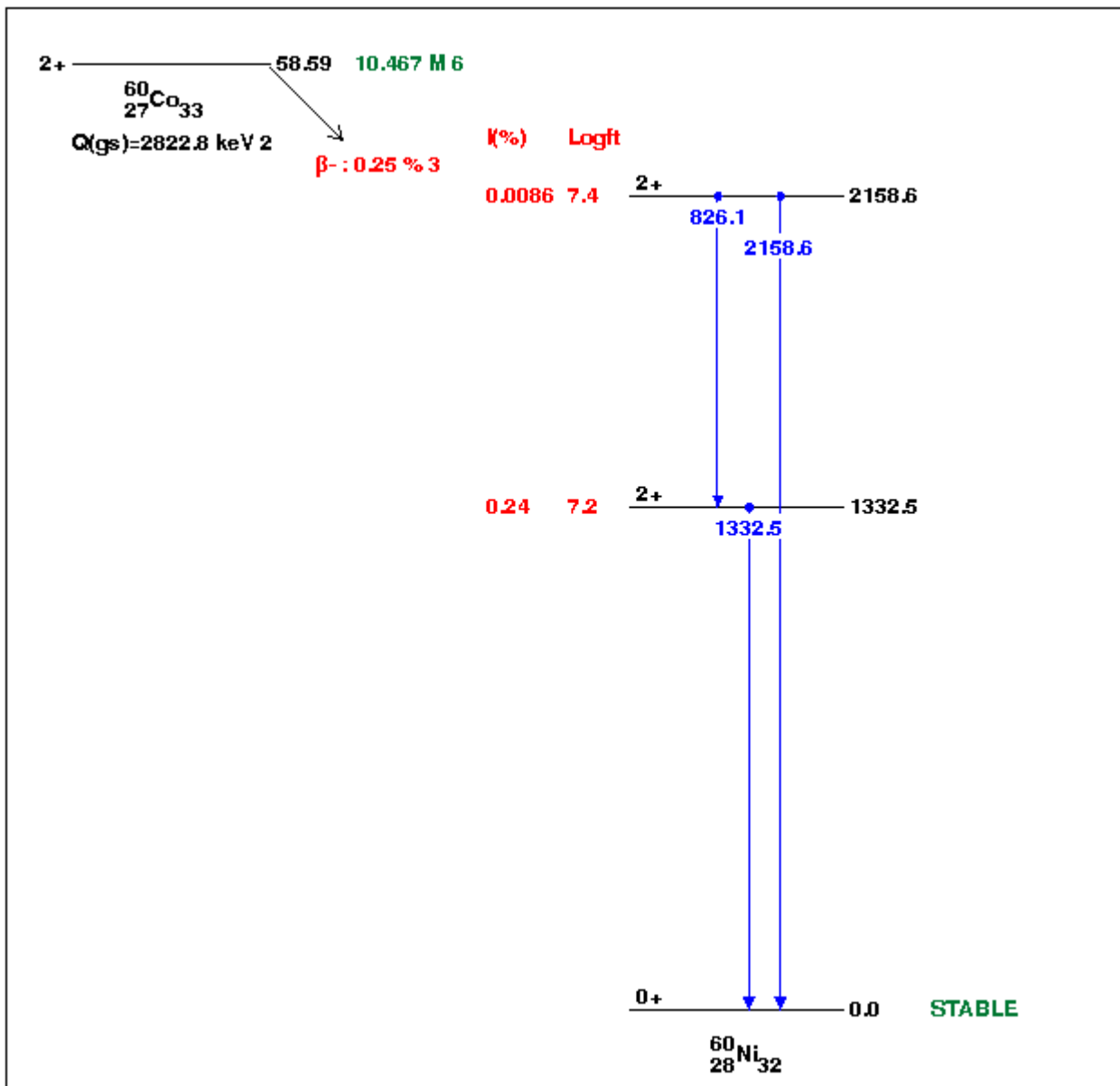

$A = 60$

$Z = 27$

$N = 33$

$^{60}_{28}\text{Ni}_{32}$

$A = 60$

$Z = 28$

$N = 32$



4b. ^{60}Co Radiation term

Radionuclide activity [A]: number of decays per unit time.

International Unit: becquerel [**Bq**], one nucleus decay per second [s^{-1}].

Nuclide	half-life	radiation	principal energies	gamma dose rate at 1 metre ($\mu\text{Sv/h/GBq}$)
Co-60	5.27 y	β^- γ	0.32 MeV (100%) 1.17 MeV (100%) 1.33 MeV (100%)	357

Therefore the dose rate of a ^{60}Co source of 1 Bq at 1 m in air is: $3.57 \cdot 10^{-7} \mu\text{Sv/h}$



4b. ^{60}Co Radiation term

It means that, the dose rate [$\mu\text{Sv/h}$] produced by a radioactive source of **1 kBq** of ^{60}Co in air is $357 \cdot 10^{-6} \mu\text{Sv/h}$:

$$\dot{D}(t) = k \times A(t)$$

And the accumulated dose over a year is:

$$D(t) = \int_0^t k \times A(t) = \int_0^t k \times A_0 \times e^{-\lambda \cdot t}$$

$$D(t) = \frac{k \cdot A_0}{\lambda} [1 - e^{-\lambda \cdot t}] ; t_{1/2} = \frac{\text{Ln}2}{\lambda} = \tau \text{Ln}2$$

$$\tau = \frac{t_{1/2}}{\text{Ln}2} = 2.398 \cdot 10^8 \text{ s} ; t_{1 \text{ year}} = 0.315 \cdot 10^8 \text{ s}$$

$$D(t_{1 \text{ year}}) = 10.5 \text{ mSv}$$



4b. ^{60}Co Radiation term

$$D(t) = k \cdot A_0 \cdot \tau \cdot [1 - e^{-t/\tau}]$$

Two Limit cases:

a. $t \ll \tau$: $e^{t/\tau} \cong 1 + \frac{t}{\tau}$

$$D(t) = k \cdot A_0 \cdot t$$

b. $t \gg \tau$: $e^{-t/\tau} \cong 0$

$$D = k \cdot A_0 \cdot \tau$$



4b. Induced Activity: proton beam

Parent isotope	Natural (%)	σ (barn)	Active isotope	Half-life	$fSv.h^{-1}$ at 1m per Bq per g	
²³ Na	100	0.53	²⁴ Na	15 h	560	7.7
⁴⁰ Ar	99.6	0.61	⁴¹ Ar	1.8 h	150	1.4
⁴⁴ Ca	2.0	0.70	⁴⁵ Ca	165 h	-	-
⁵⁰ Cr	4.3	17	⁵¹ Cr	28 d	4	0.04
⁵⁵ Mn	100	13	⁵⁶ Mn	2.6 h	2520	35
⁵⁹ Co	100	37	⁶⁰ Co	5.3 y	340	128
⁶³ Cu	69	4.5	⁶⁴ Cu	13 h	28	0.84
⁶⁴ Zn	49	0.46	⁶⁵ Zn	245 d	76	0.16
¹²¹ Sb	57	6.1	¹²² Sb	2.8 d	60	1.0
¹²³ Sb	43	3.3	¹²⁴ Sb	60 d	200	1.4
¹³³ Cs	100	31	¹³⁴ Cs	2.1 y	116	17
¹⁵¹ Eu	48	8700	¹⁵² Eu	12 y	45	750
¹⁵³ Eu	52	320	¹⁵⁴ Eu	8 y	286	190
¹⁸⁶ W	28	40	¹⁸⁷ W	1d	73	2.6

Most important isotopes near high energy particle accelerators formed by thermal neutron capture



4b. Example-1: ISIS TS1 target

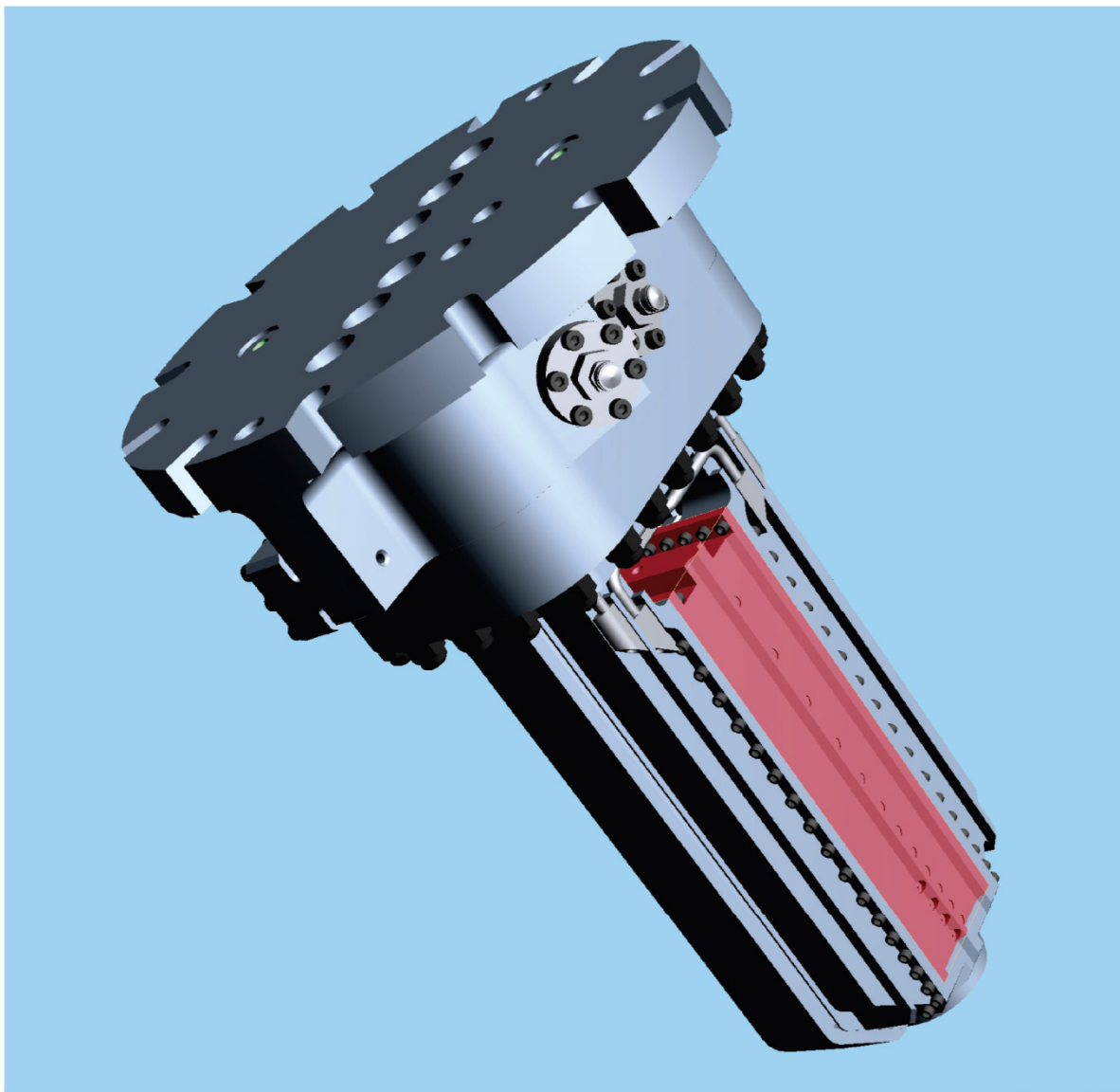

Target CAN

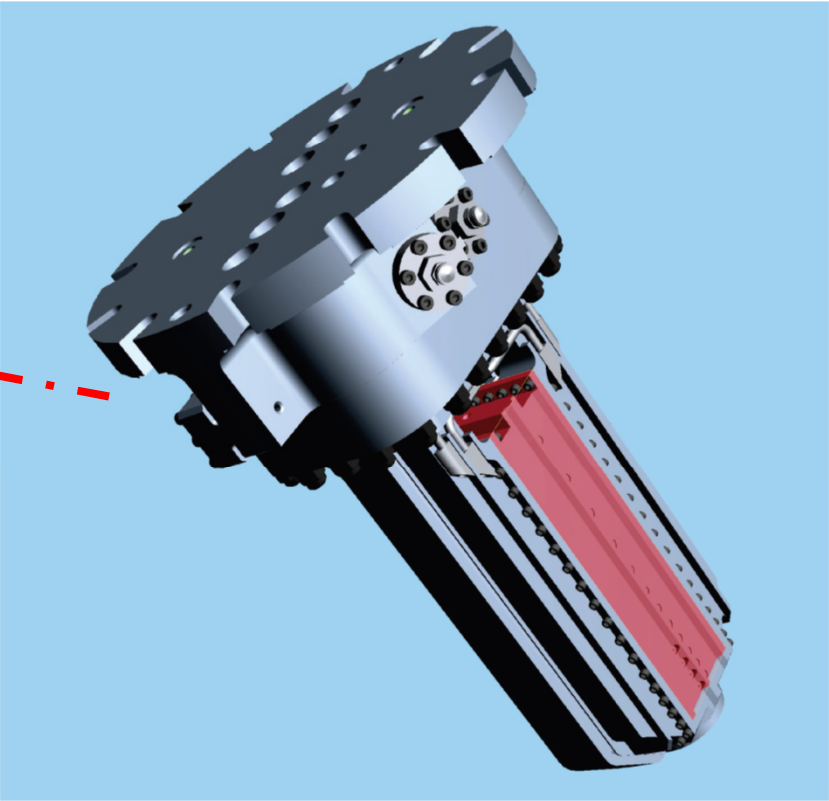
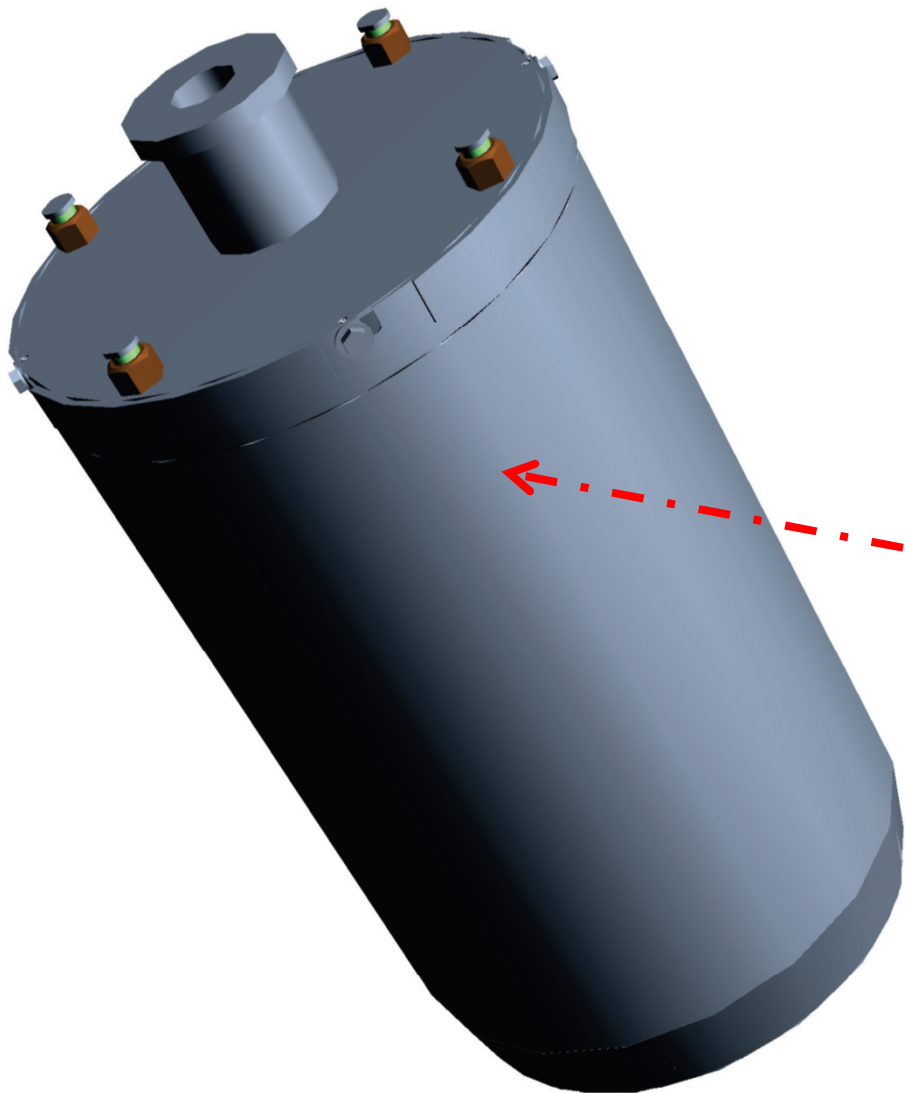

Target FLASK

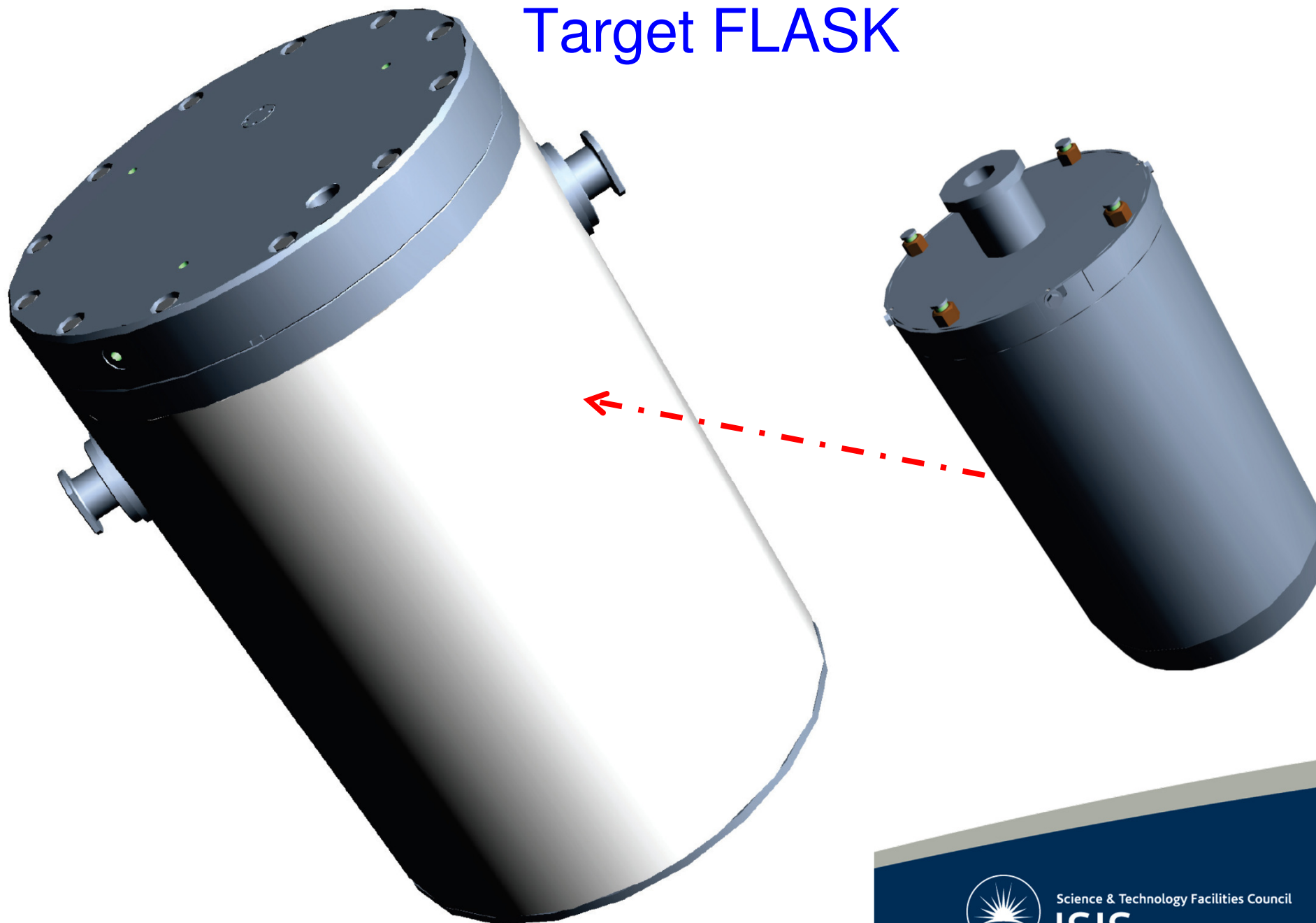

Science & Technology Facilities Council

ISIS

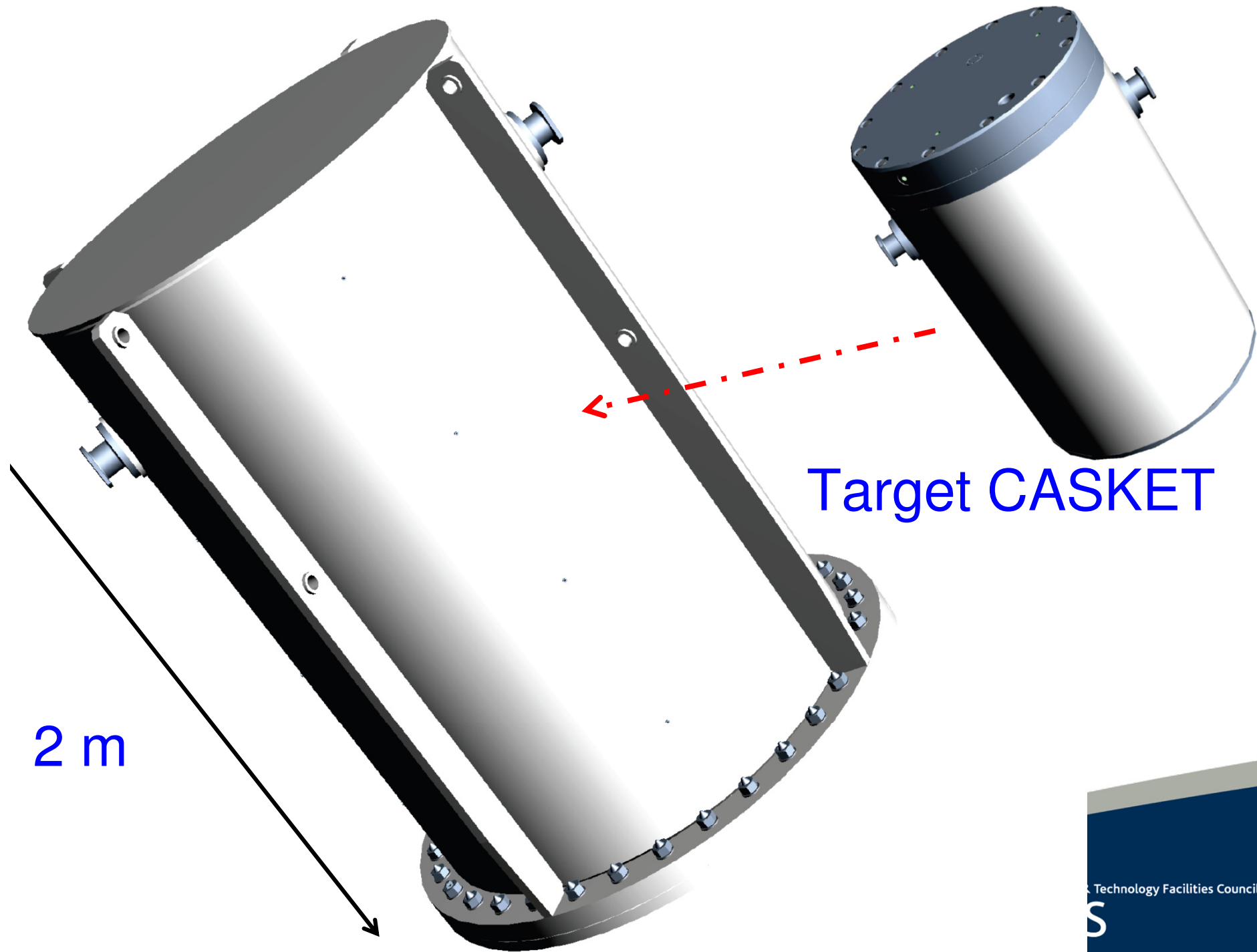

2 m

Target CASKET

4b. Example-1: ISIS TS1 target

Irradiation Time [y]	Cooling time [y]	Dose rate TOP [mSv/h]	(x5 all the activities values)										
4	0	292.42											
4	3	1.19											
4	4	0.69											
4	5	0.48											
4	6	0.35											
4	6.5	0.30											
			Total DR after 0 seconds of cooling [mSv/h]	292.42	100.0%	Total DR after 3 years of cooling	1.19	100.0%	Total DR after 4 years of cooling	0.69	100.0%		
#CL	Nuclide	Halflive [s]	A0 (after 4 years irradiation)	DoseRate[mSv/h;3.7E10Bq]	DR[mSv/h]	%DR	A3y[Bq]	DR[mSv/h]	%DR	A4y[Bq]	DR[mSv/h]	%DR	
1	Lu172	5.79E+05	1.62E+14	7.25E-04	3.18E+00	1.09E-02	3.69E+13	7.24E-01	6.06E-01	2.62E+13	5.137E-01	7.42E-01	
2	Co60	1.66E+08	1.26E+12	3.28E-03	1.12E-01	3.81E-04	8.42E+11	7.46E-02	6.25E-02	7.45E+11	6.605E-02	9.54E-02	
3	Hf172	5.90E+07	1.14E+14	9.38E-05	2.88E-01	9.87E-04	3.66E+13	9.27E-02	7.76E-02	2.60E+13	6.579E-02	9.50E-02	
4	Ta182	9.89E+06	4.44E+16	2.13E-04	2.55E+02	8.74E-01	5.07E+13	2.92E-01	2.44E-01	6.55E+12	3.767E-02	5.44E-02	
5	Lu174	1.05E+08	8.91E+12	4.76E-05	1.15E-02	3.92E-05	4.73E+12	6.08E-03	5.09E-03	3.90E+12	5.015E-03	7.24E-03	
6	Eu152	4.21E+08	1.53E+11	7.86E-04	3.26E-03	1.11E-05	1.31E+11	2.78E-03	2.33E-03	1.25E+11	2.650E-03	3.83E-03	
7	Mn54	2.70E+07	1.31E+14	6.77E-06	2.40E-02	8.22E-05	1.10E+13	2.00E-03	1.68E-03	5.17E+12	9.462E-04	1.37E-03	
8	Sc44	1.41E+04	1.55E+13	4.67E-04	1.96E-01	6.70E-04	2.42E+10	3.06E-04	2.56E-04	2.39E+10	3.015E-04	4.35E-04	
9	Ti44	1.49E+09	2.53E+10	1.56E-04	1.06E-04	3.64E-07	2.42E+10	1.02E-04	8.52E-05	2.39E+10	1.004E-04	1.45E-04	
10	Co56	6.81E+06	1.60E+13	1.71E-02	7.38E+00	2.52E-02	8.57E+08	3.95E-04	3.31E-04	4.38E+07	2.022E-05	2.92E-05	
						266.64 8.8%				1.19 0.005%			0.69 0.003%
			Total DR after 5 years of cooling	0.48	100.0%	Total DR after 6 years of cooling	0.3507	100.0%	Total DR after 6.5 years of cooling	0.30	100.0%		
			A5y[Bq]	DR[mSv/h]	%DR	A6y[Bq]	DR[mSv/h]	%DR	A6.5y[Bq]	DR[mSv/h]	%DR		
			1.86E+13	3.65E-01	7.56E-01	1.32E+13	2.587E-01	7.38E-01	1.11E+13	2.18E-01	7.25E-01		
			6.60E+11	5.85E-02	1.21E-01	5.84E+11	5.180E-02	1.48E-01	5.50E+11	4.87E-02	1.62E-01		
			1.84E+13	4.67E-02	9.68E-02	1.31E+13	3.313E-02	9.45E-02	1.10E+13	2.79E-02	9.28E-02		
			8.46E+11	4.87E-03	1.01E-02	1.09E+11	6.287E-04	1.79E-03	3.93E+10	2.26E-04	7.51E-04		
			3.21E+12	4.14E-03	8.58E-03	2.65E+12	3.412E-03	9.73E-03	2.41E+12	3.10E-03	1.03E-02		
			1.19E+11	2.53E-03	5.24E-03	1.13E+11	2.407E-03	6.86E-03	1.11E+11	2.35E-03	7.81E-03		
			2.44E+12	4.47E-04	9.27E-04	1.15E+12	2.110E-04	6.02E-04	7.93E+11	1.45E-04	4.82E-04		
			2.35E+10	2.97E-04	6.17E-04	2.32E+10	2.934E-04	8.37E-04	2.31E+10	2.91E-04	9.69E-04		
			2.35E+10	9.91E-05	2.05E-04	2.32E+10	9.774E-05	2.79E-04	2.31E+10	9.71E-05	3.23E-04		
			2.24E+06	1.03E-06	2.14E-06	1.15E+05	5.287E-08	1.51E-07	2.59E+04	1.20E-08	3.97E-08		
			0.48 0.002%			0.35 0.001%			0.30 0.001%				



4c. RF generator plants

a. IOT:

to RF Cavity

b. Klystron:

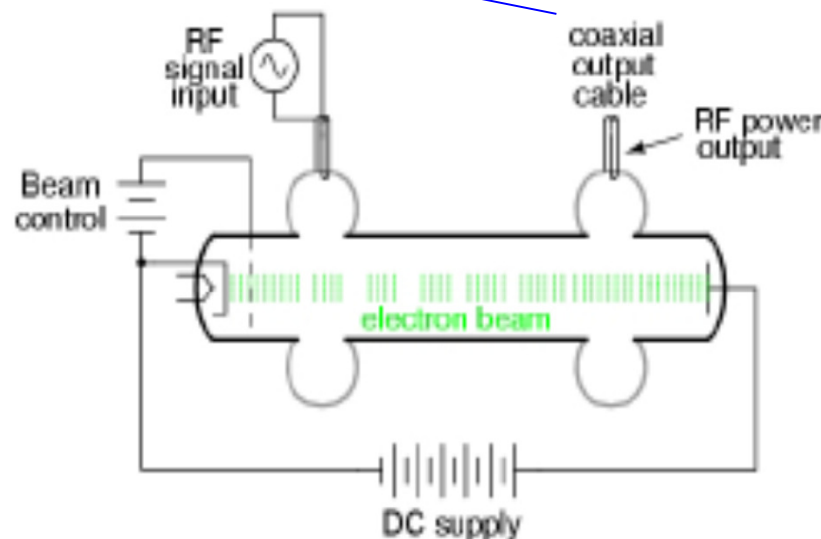
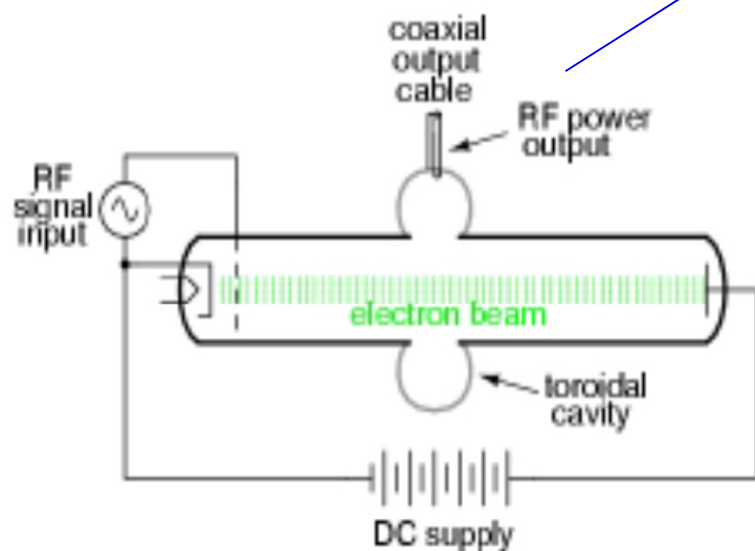

IOT (Inductive Output Tube)

$G \approx 23$ dB (for comparison: Tetrode $G \approx 15$ dB)

Intensity modulated

Class AB

Peak efficiency $\approx 75\%$

Compact size

Klystron

$G \approx 40$ dB

Velocity modulated

Class A

Peak efficiency $\approx 65\%$



4c. RF generator plants

RF Storage Ring Cavity

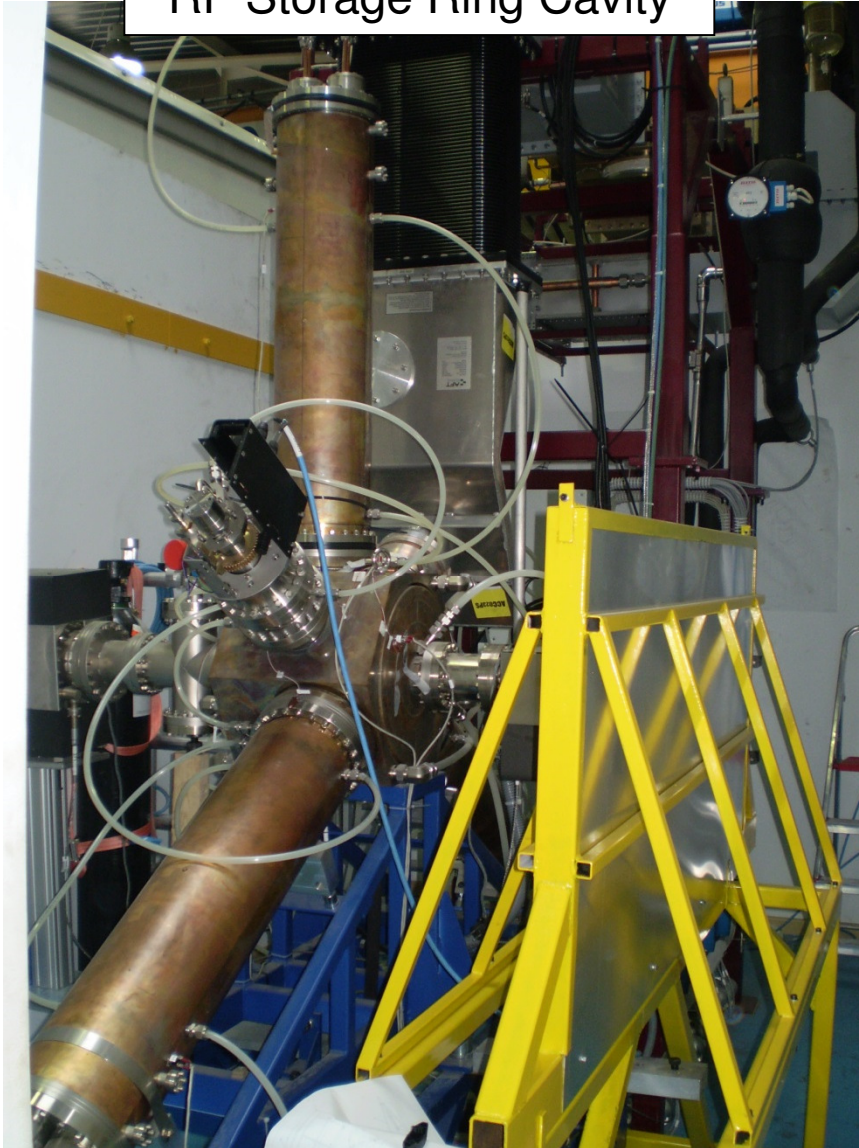

RF Booster Cavity

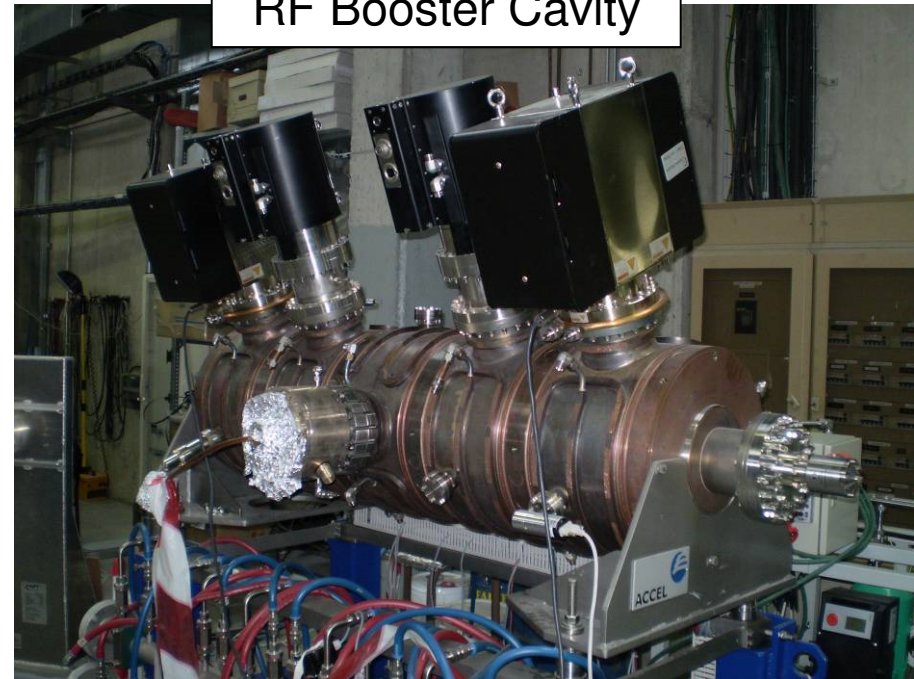

4c. RF generator plants

RADIATION MEASUREMENTS: IOT

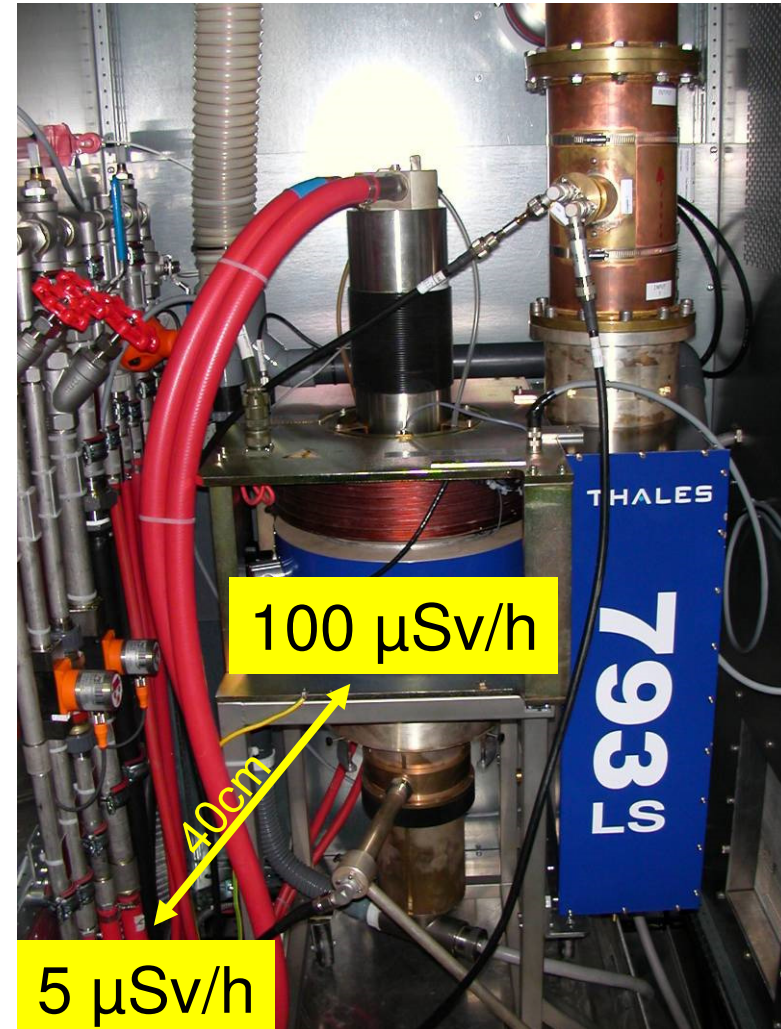

4c. RF generator plants

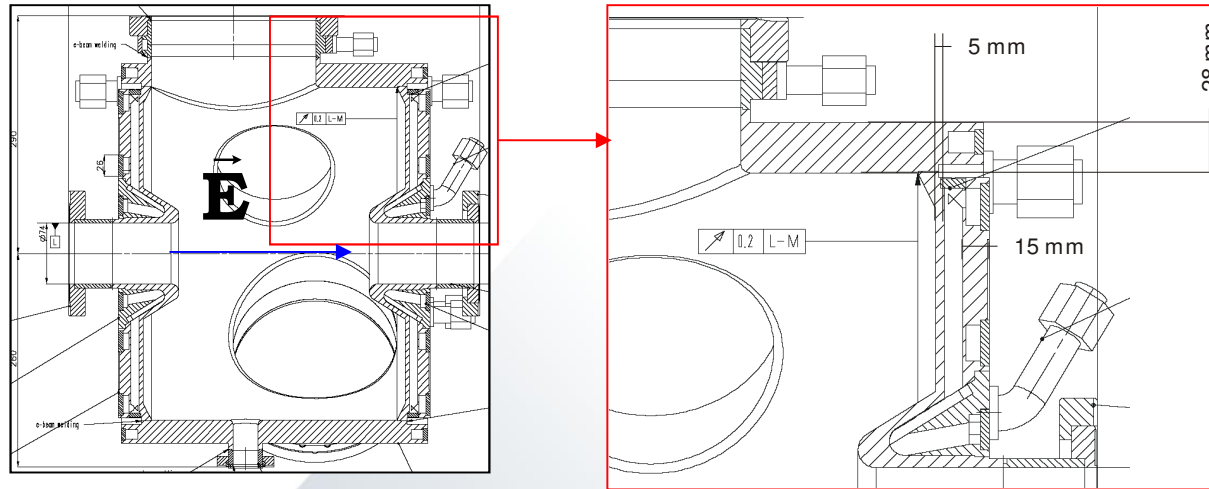

	<i>Booster</i>	<i>Storage Ring</i>
Voltage on axis (kV)	1350	750
Maximum E field on surface (MV/m)	2.0	6.2

$$j(E_{SUP}) = \frac{A_{FN} \cdot (\beta \cdot E_{SUP})^2}{\phi} \times \exp \left[- \frac{B_{FN} \cdot \phi^{3/2}}{\beta \cdot E_{SUP}} \right]$$

4c. RF generator plants

RAD. MEAS.: DOSE RATE ON SURFACE

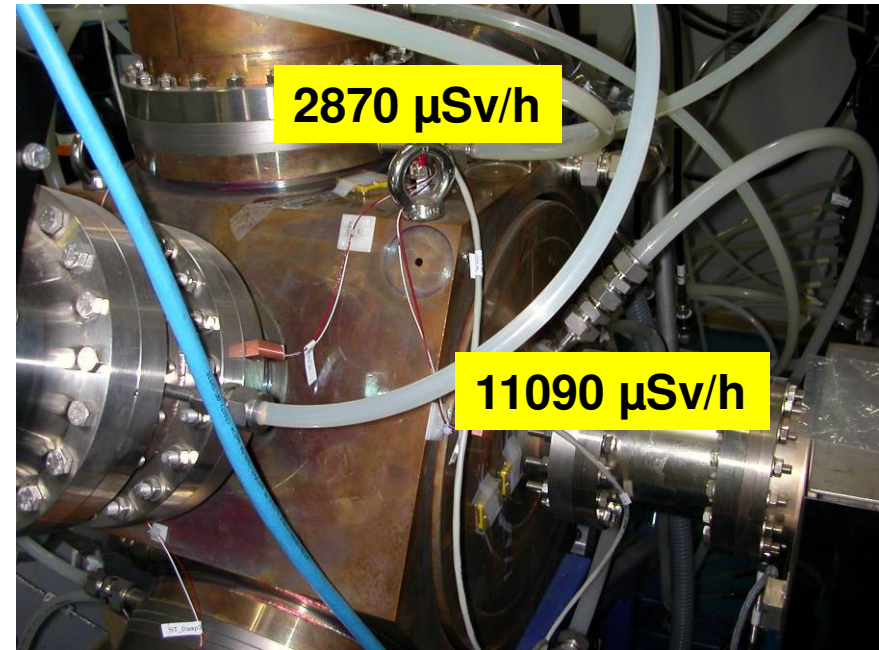
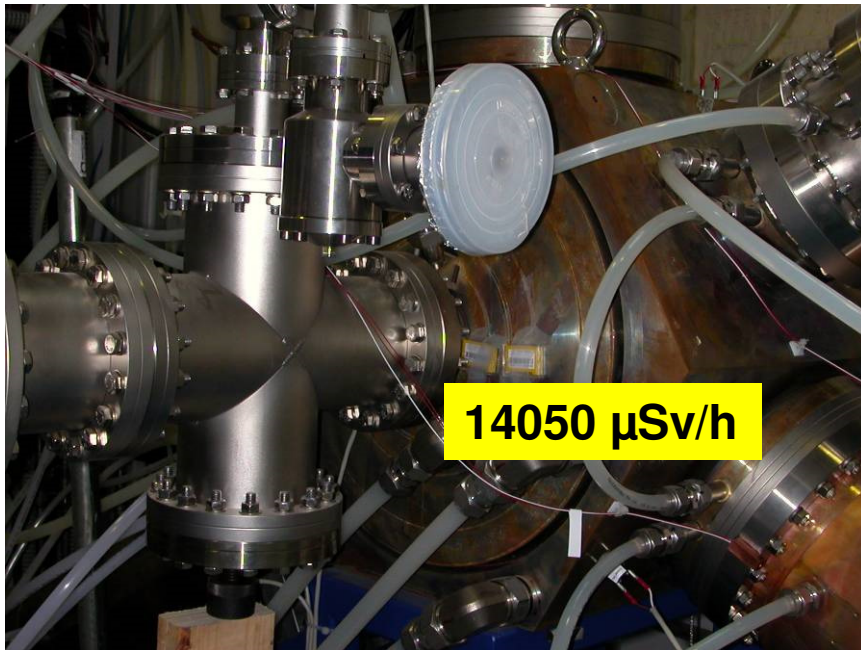

80kW (max power) @ 20%



4c. RF generator plants

