

# Part2: Cavities and Structures

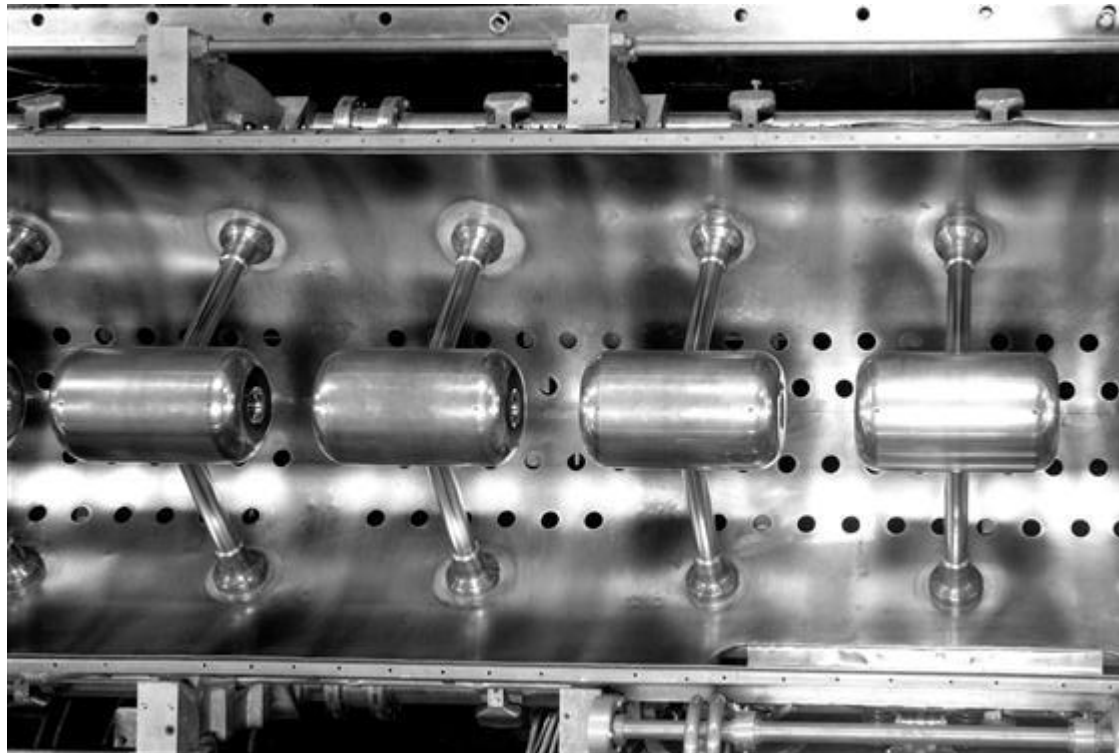

JUAS 2017

- Modes in resonant cavity
- From a cavity to an accelerator
- Examples of structures



Linacs-JB.Lallement - JUAS 2017



## Maxwell equation for electromagnetics waves

$$\left( \frac{d^2}{dx^2} + \frac{d^2}{dy^2} + \frac{d^2}{dz^2} - \frac{1}{c^2} \frac{d^2}{dt^2} \right) \vec{E} = 0$$

$$\left( \frac{d^2}{dx^2} + \frac{d^2}{dy^2} + \frac{d^2}{dz^2} - \frac{1}{c^2} \frac{d^2}{dt^2} \right) \vec{B} = 0$$

- In free space the electromagnetic fields are of the transverse electromagnetic, TEM type: Electric and magnetic field vectors are  $\perp$  to each other and to the direction of propagation !
- In a bounded medium (cavity) the solution of the equation must satisfy the boundary conditions:

$$\begin{aligned} \vec{E}_{\parallel} &= \vec{0} \\ \vec{B}_{\perp} &= \vec{0} \end{aligned}$$

# TE and TM modes



- TE mode (transverse electric): The electric field is perpendicular to the direction of propagation in a cylindrical cavity.

$$TE_{mn}$$

m: azimuthal  
n: radial

- TM mode (transverse magnetic): The magnetic field is perpendicular to the direction of propagation in a cylindrical cavity.

$$TM_{mn}$$

m: azimuthal  
n: radial

# TE modes



- The two Transverse Electric modes for accelerating structures are:

$TE_{11}$ : Dipole mode

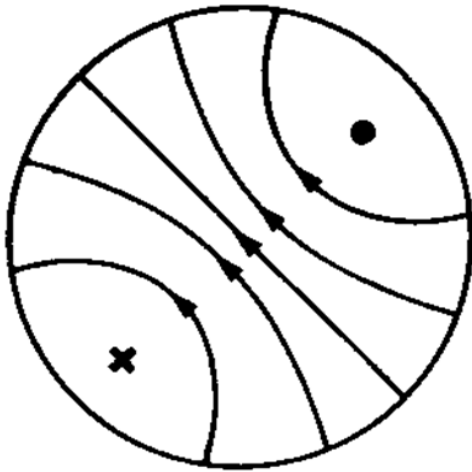

Empty cavity; mode  $TE_{11}$

$TE_{21}$ : Quadrupole mode

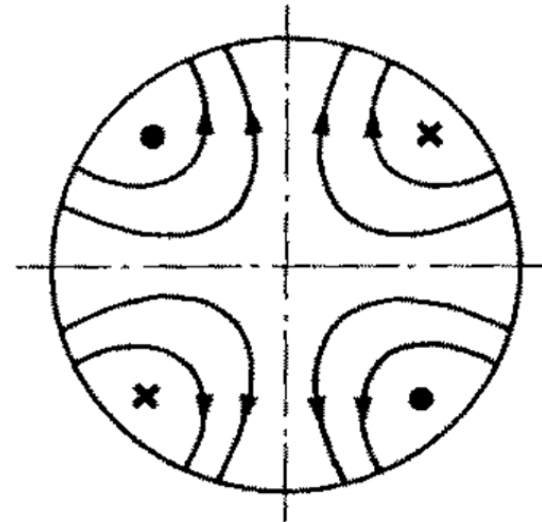

Empty cavity; mode  $TE_{21}$

# TM modes



- The most commonly used Transverse Magnetic mode for accelerating structures is:

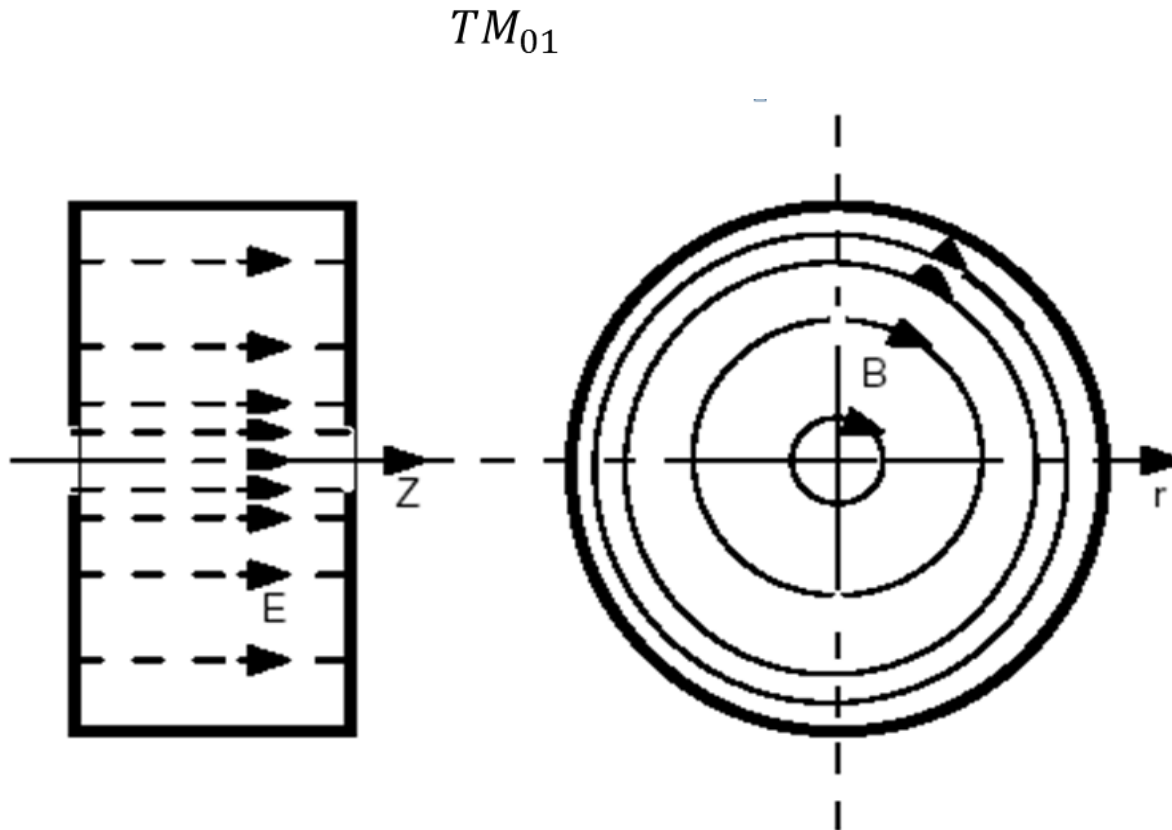

# TM modes



- The most commonly used for accelerating structures are the TM modes:

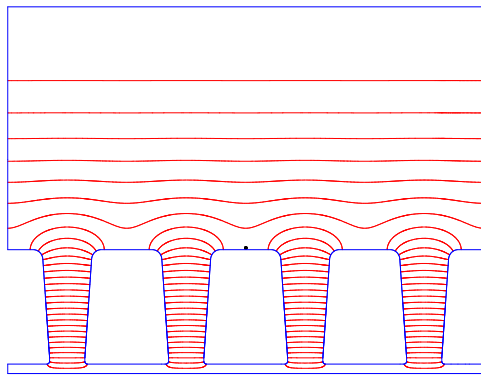
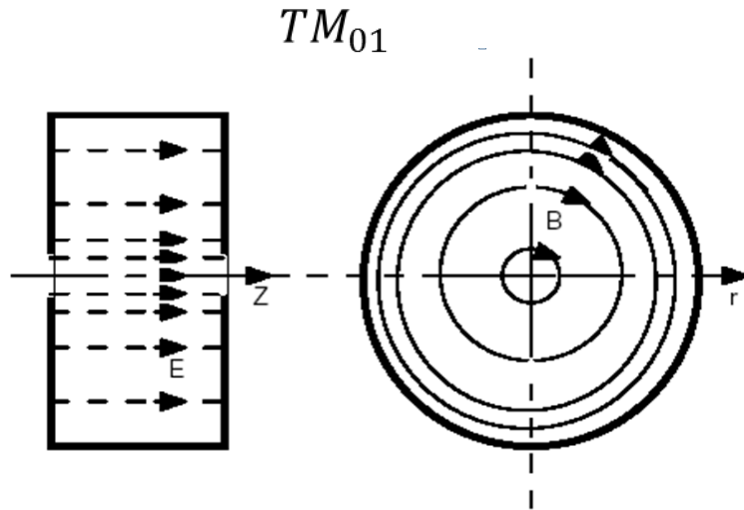

$TM_{010} : f=352.2 \text{ MHz}$

Sample Multiple Drift Tube Cavity Freq = 548.328

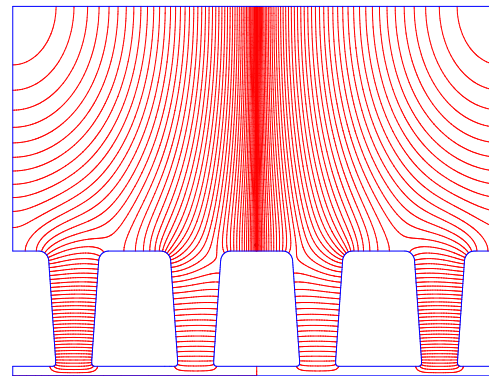

$TM_{011} : f=548 \text{ MHz}$

Sample Multiple Drift Tube Cavity Freq = 951.901

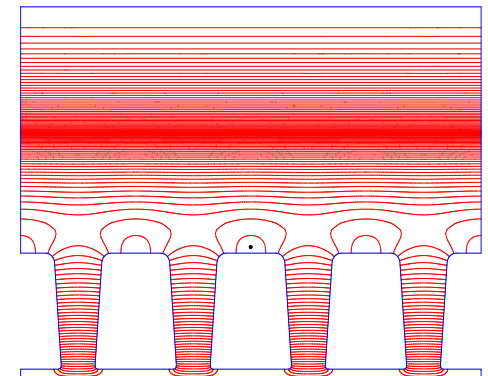

$TM_{020} : f=952 \text{ MHz}$

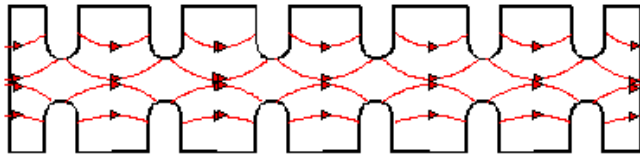

mode 0

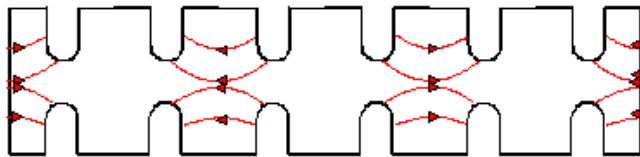

mode  $\pi/2$

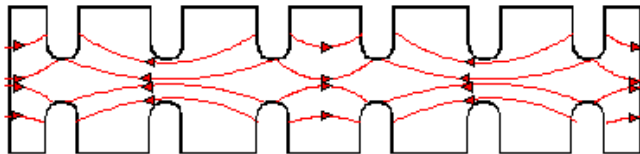

mode  $2\pi/3$

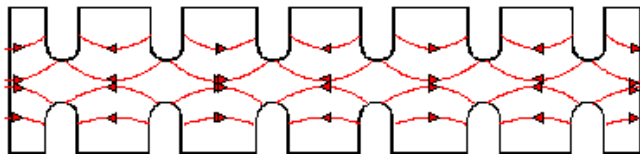

mode  $\pi$

Mode 0 also called mode  $2\pi$ .

For synchronicity and acceleration, particles must be in phase with the E field on axis (will be discussed more in details in part.3).

During 1 RF period, the particles travel over a distance of  $\beta\lambda$ .

The cell L length should be:

Mode	L
$2\pi$	$\beta\lambda$
$\pi/2$	$\beta\lambda/4$
$2\pi/3$	$\beta\lambda/3$
$\pi$	$\beta\lambda/2$

Named from the phase difference between adjacent cells.

# Basic accelerating structures

- TE mode:
  - Radio Frequency Quadrupole: RFQ
  - Interdigital-H structure: IH
- TM mode:
  - Drift Tube Linac: DTL
  - Cavity Coupled DTL: CCDTL
  - PI Mode Structure: PIMS
  - Superconducting cavities

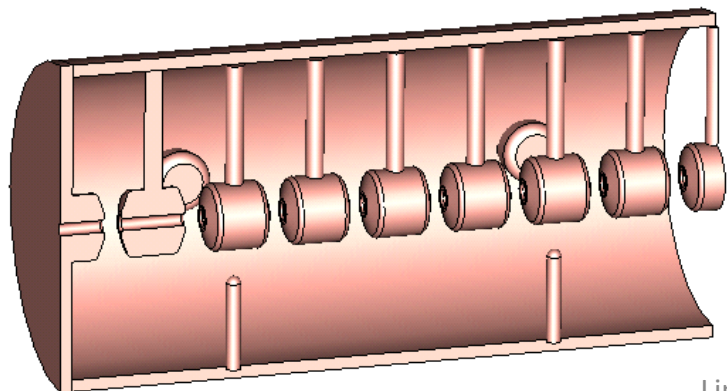
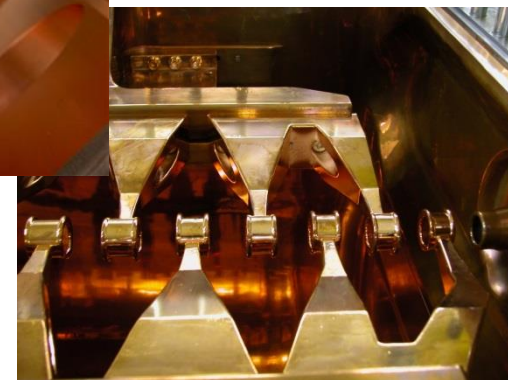



# Radio Frequency Quadrupole

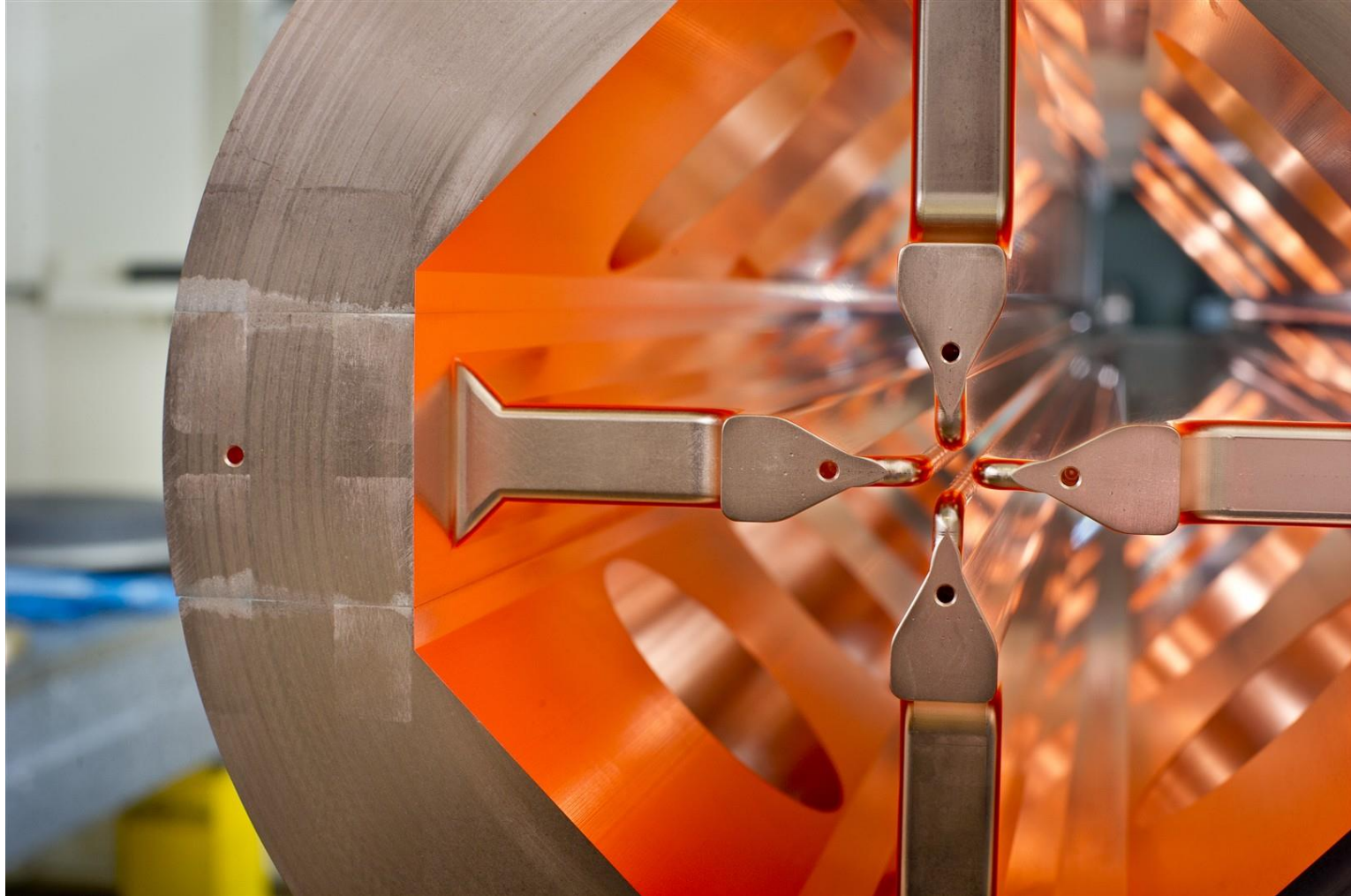

# Radio Frequency Quadrupole

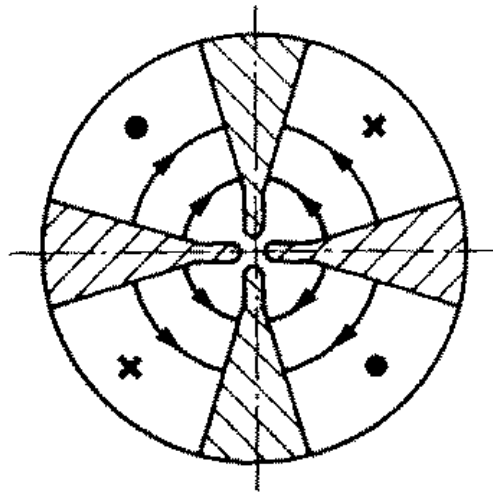
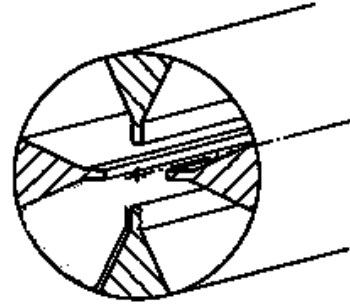
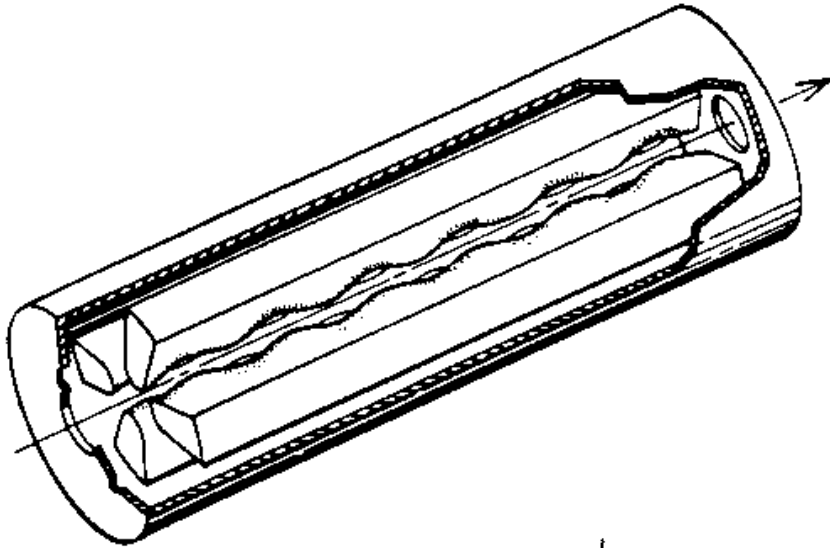

Cavity with vanes

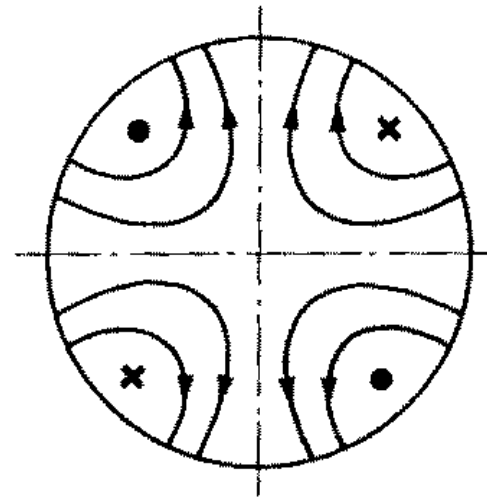

Empty cavity; mode  $TE_{21}$



# Radio Frequency Quadrupole

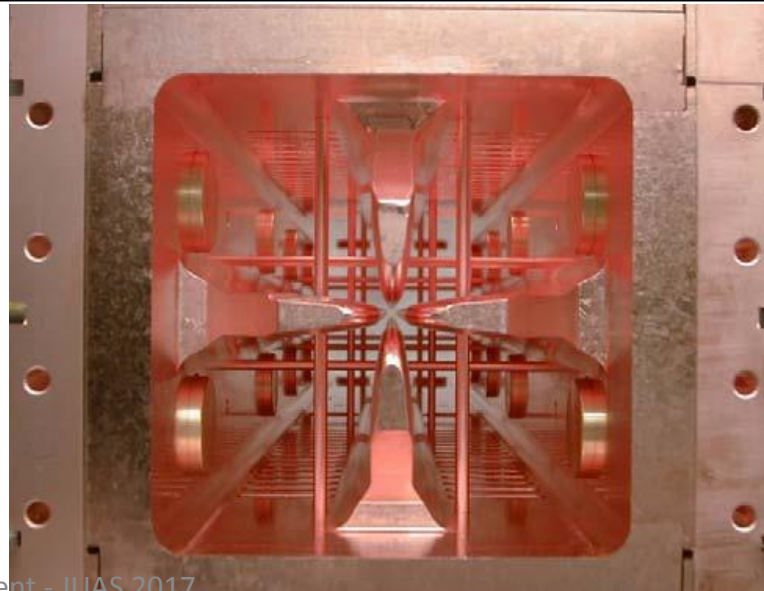
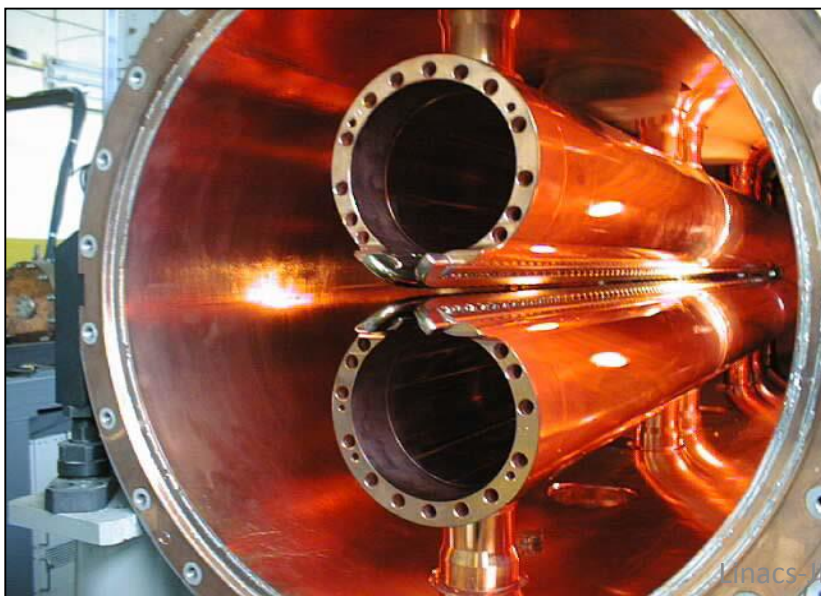
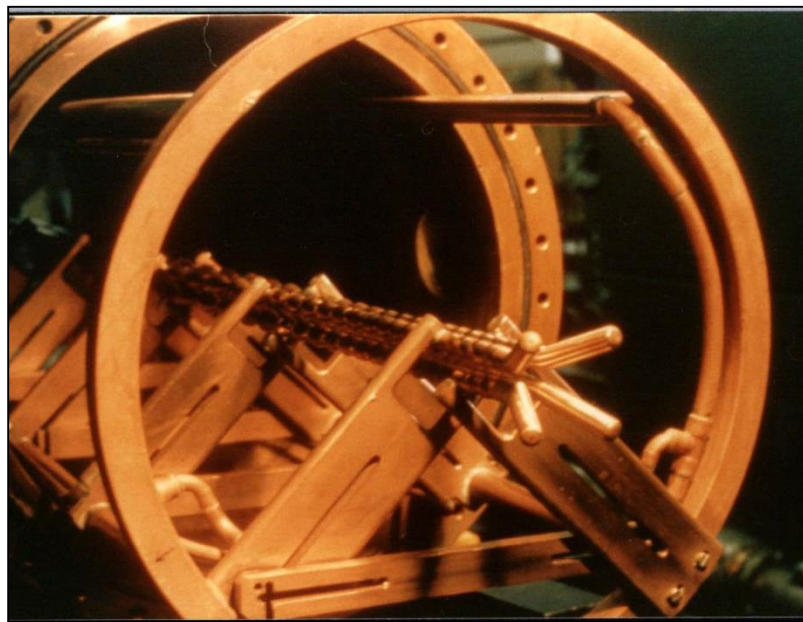
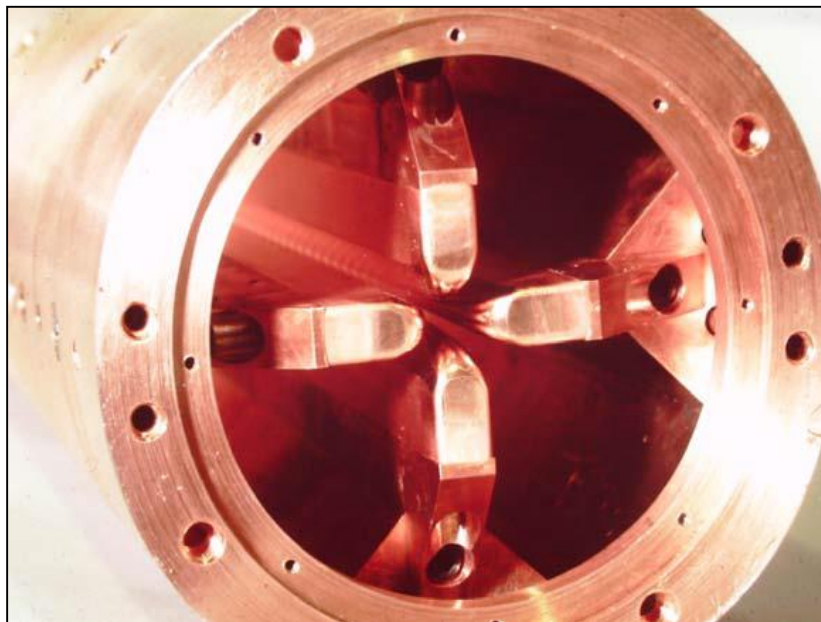

# 4 vane-structure

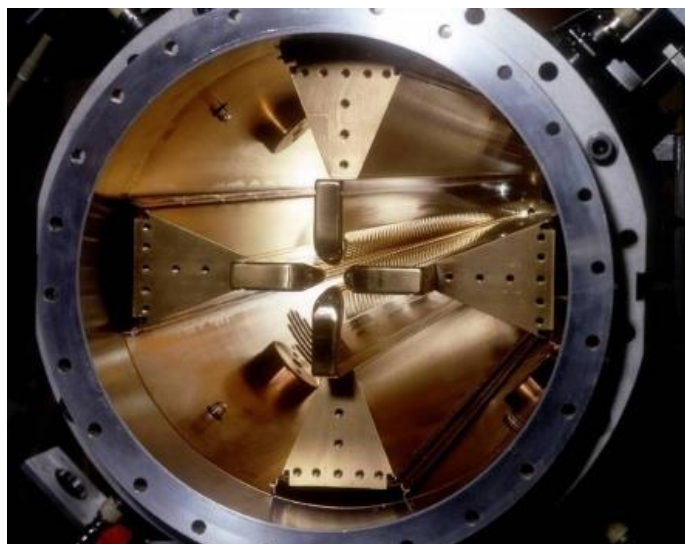
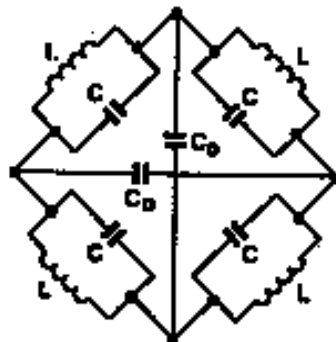
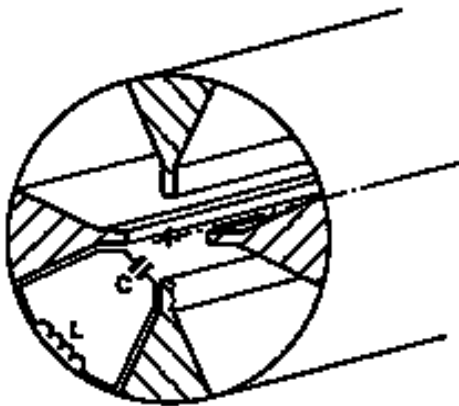

1. Capacitance between vanes, inductance in the intervane volume.
2. Each quadrant is a resonator
3. Frequency depends on cylinder dimensions.
4. Vane tip are machined by a computer controlled milling machine.
5. Need stabilization (problem of mixing with dipole mode TE<sub>11</sub>).

# Radio Frequency Quadrupole

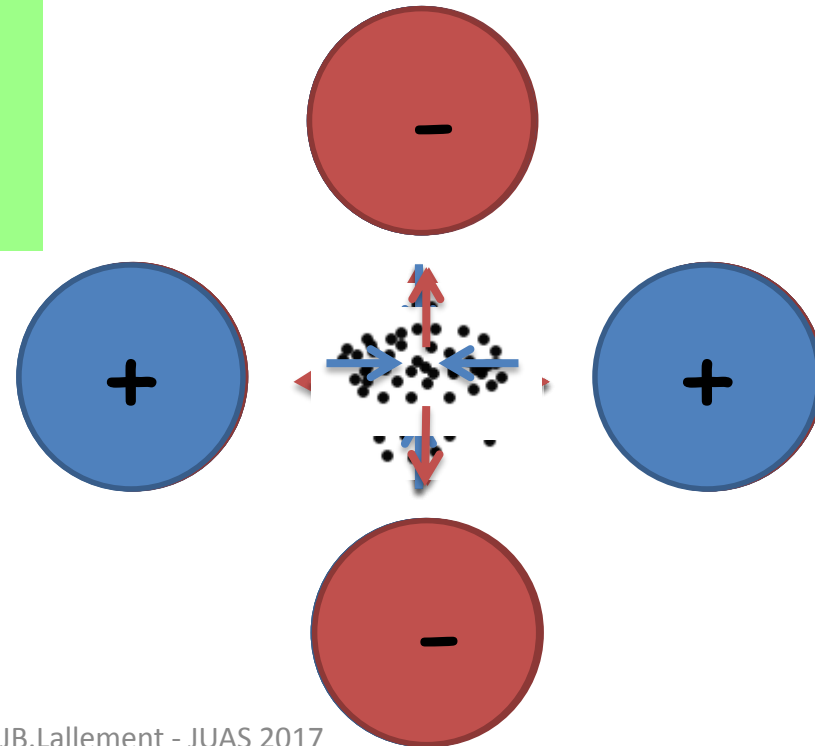
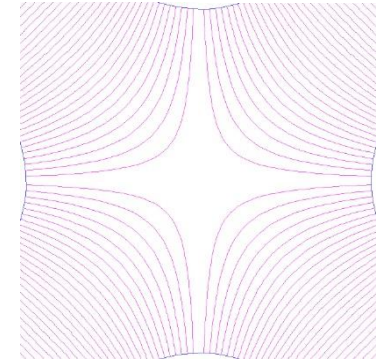
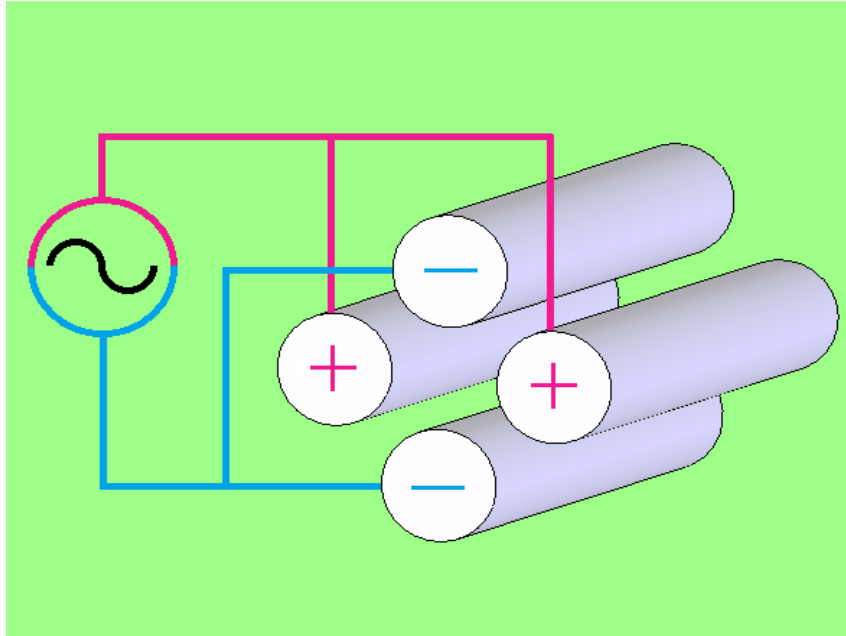



# Acceleration in RFQ

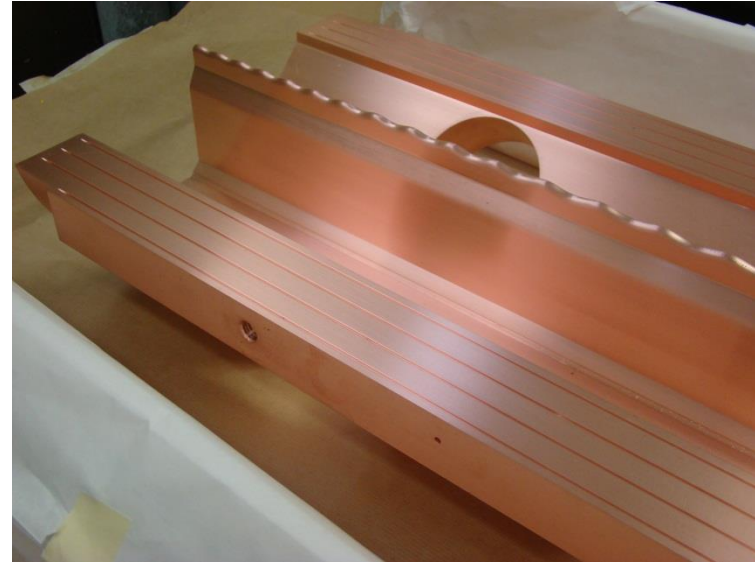
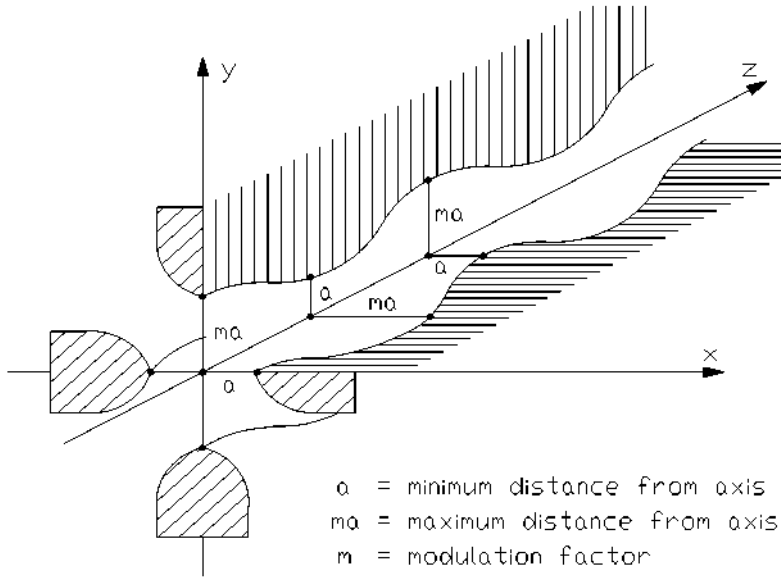

longitudinal modulation on the electrodes creates a longitudinal component in the TE mode

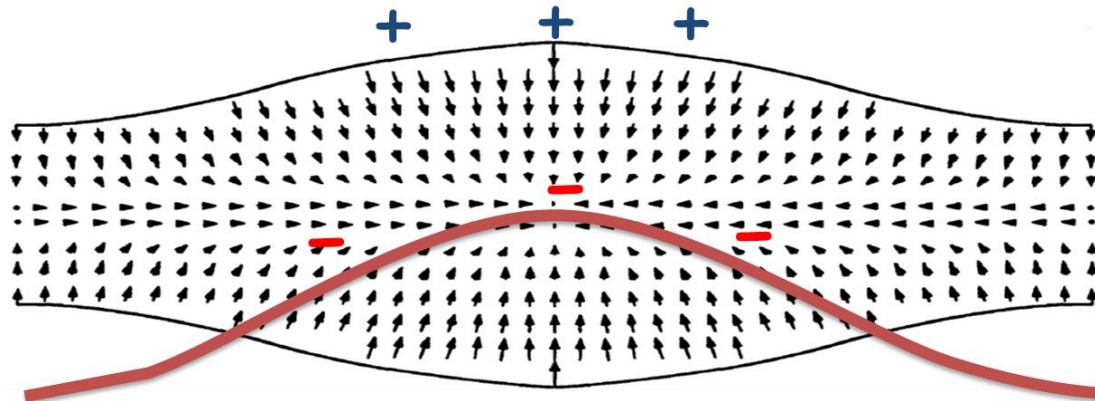



$$B = \left( \frac{q}{m_0} \right) \left( \frac{V}{a} \right) \left( \frac{1}{f^2} \right) \frac{1}{a} \left( \frac{I_0(ka) + I_0(mka)}{m^2 I_0(ka) + I_0(mka)} \right)$$

Focusing term

$$E_0 T = \frac{m^2 - 1}{m^2 I_0(ka) + I_0(mka)} \cdot V \frac{2}{\beta \cdot \lambda} \frac{\pi}{4}$$

Acceleration term

a=bore radius

m=modulation

$m_0$ =rest mass

$\beta$ =reduced velocity

$\lambda$ =wave length

f=frequency

k=wave number

V=vane voltage

$I_{0,1}$ = zero and first order Bessel function

$$\left( \frac{I_0(ka) + I_0(mka)}{m^2 I_0(ka) + I_0(mka)} \right) + \frac{m^2 - 1}{m^2 I_0(ka) + I_0(mka)} \cdot I_0(ka) = 1$$



- The resonating mode of the cavity is a focusing mode
- Alternating the voltage on the electrodes produces an alternating focusing channel
- A longitudinal modulation of the electrodes produces a field in the direction of propagation of the beam which bunches and accelerates the beam
- Both the focusing as well as the bunching and acceleration are performed by the RF field
- The RFQ is the only linear accelerator that can accept a low energy CONTINUOUS beam of particles
- 1970 Kapchinskij and Teplyakov propose the idea of the radiofrequency quadrupole ( I. M. Kapchinskii and V. A. Teplvakov, Prib.Tekh. Eksp. No. 2, 19 (1970))

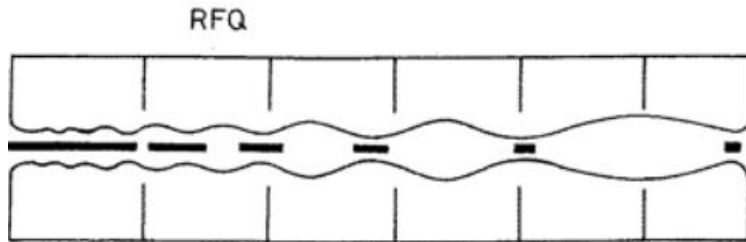

Acceleration  
Bunching  
Transverse focusing



# Interdigital H structure

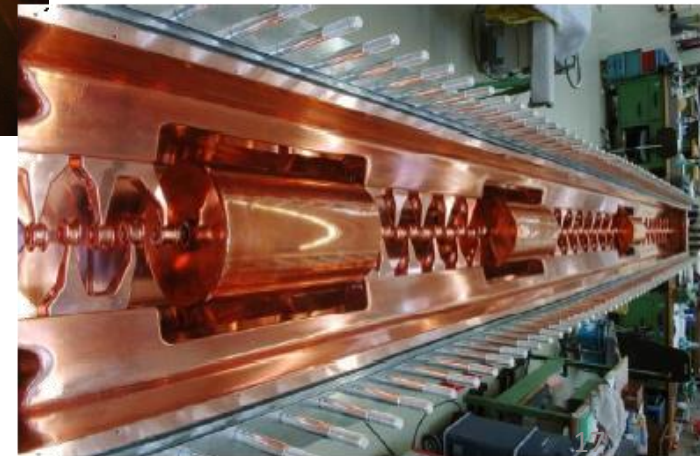
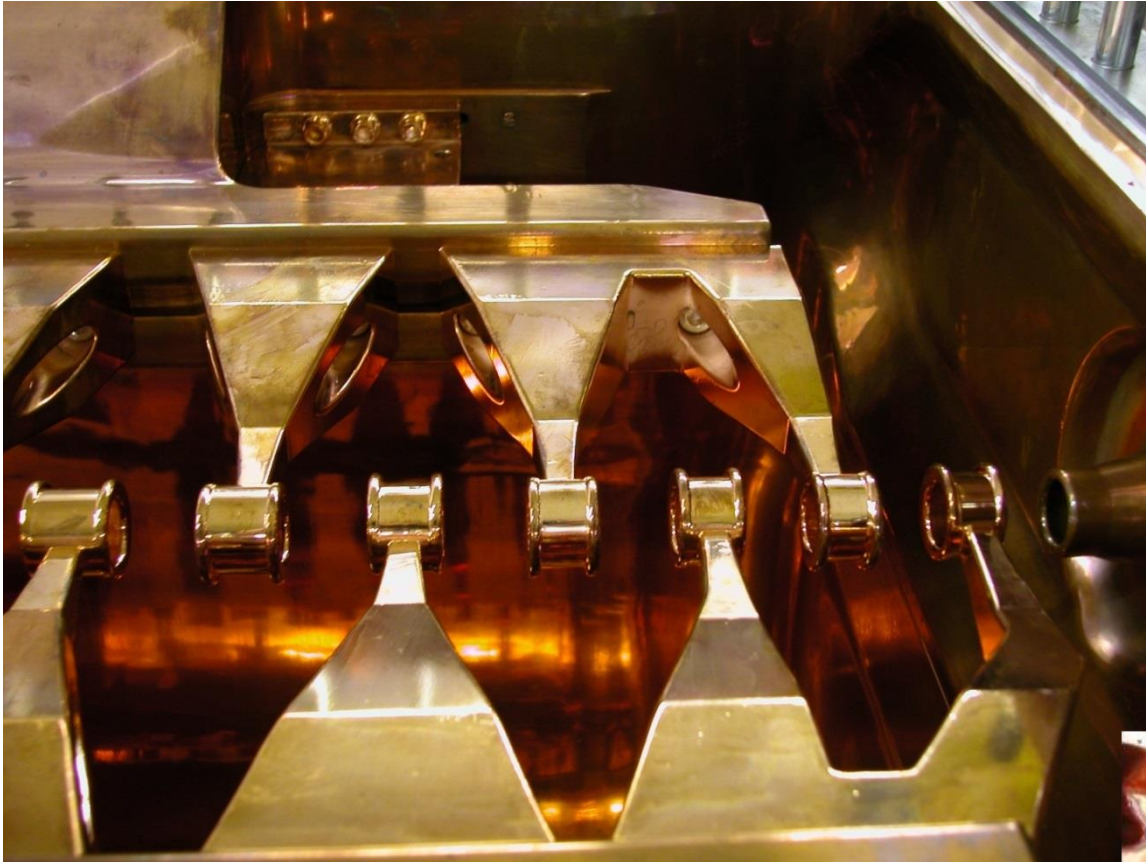

# Interdigital H structure

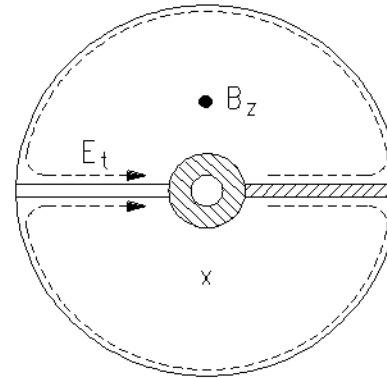
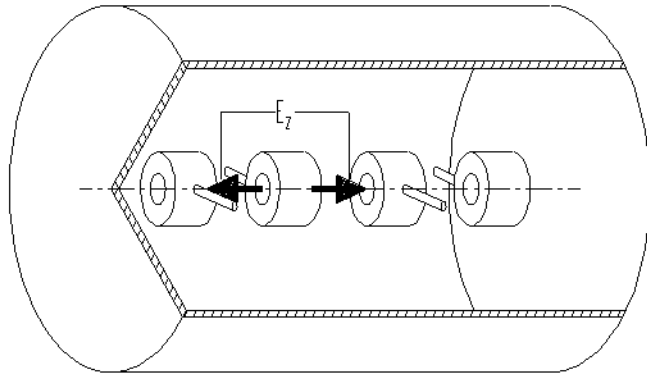

TE<sub>11</sub> mode

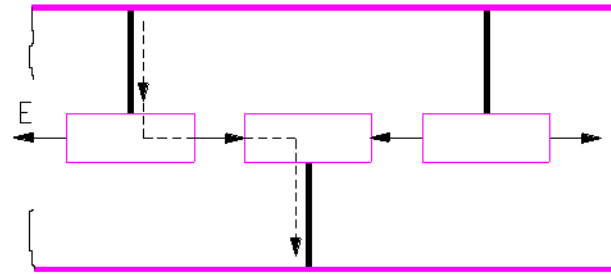
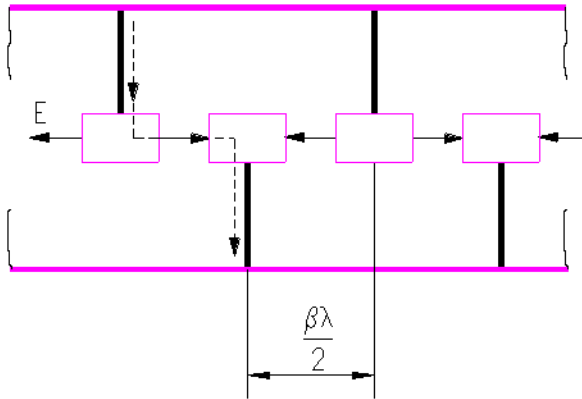

- Stem on alternating side of the drift tube force a longitudinal field between the drift tubes

- Focalisation is provided by quadrupole triplets places OUTSIDE the drift tubes or OUTSIDE the tank

# Interdigital H structure



- very good shunt impedance in the low beta region ( $\beta \cong 0.02$  to  $0.08$ ) and low frequency (up to 200MHz)
- not for high intensity beam due to long focusing period
- ideal for low beta heavy ion acceleration

# Drift Tube Linac

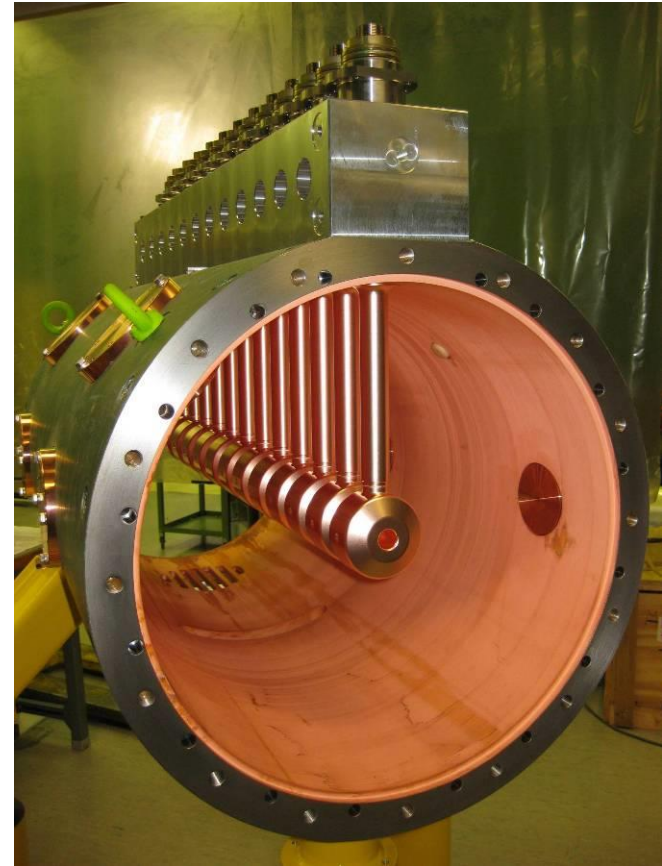
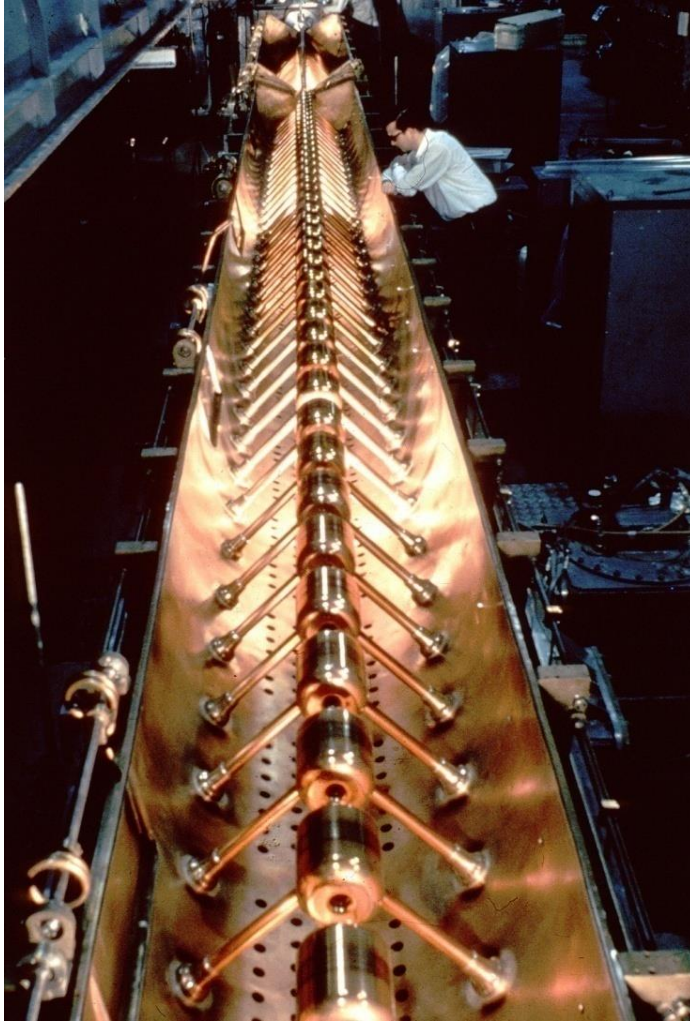



# Drift Tube Linac

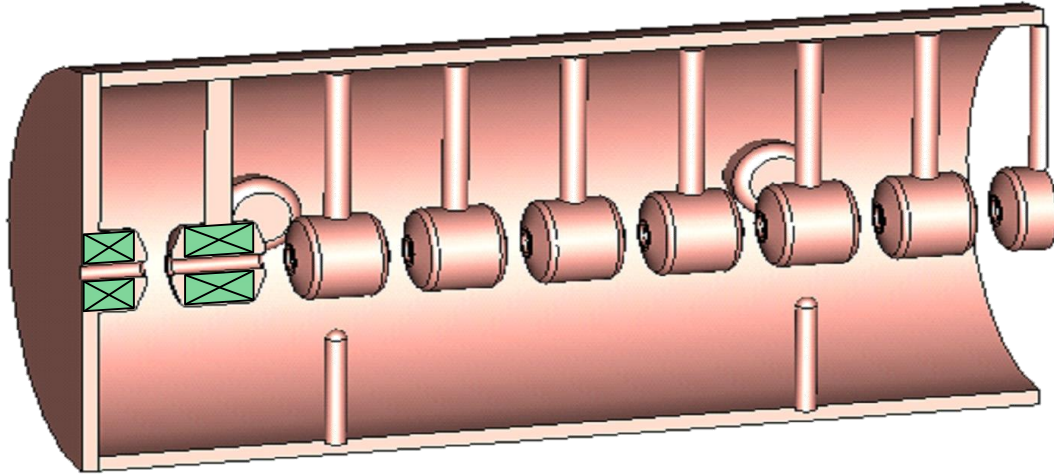

Tutorial !

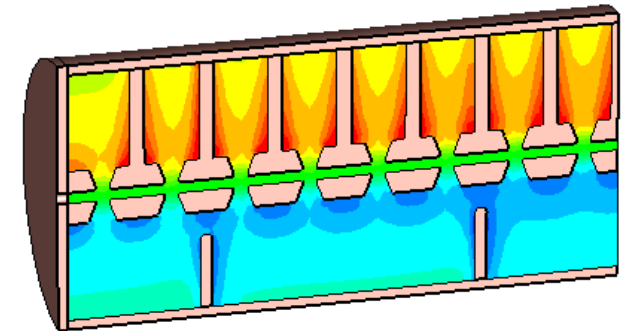
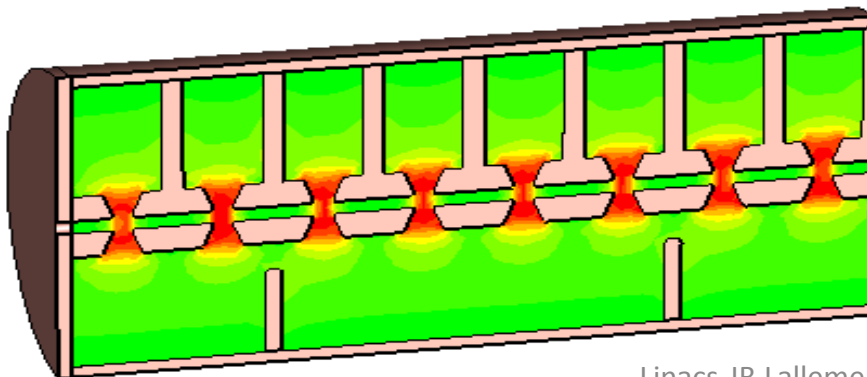
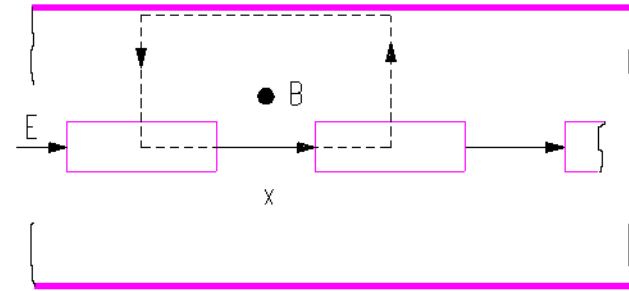
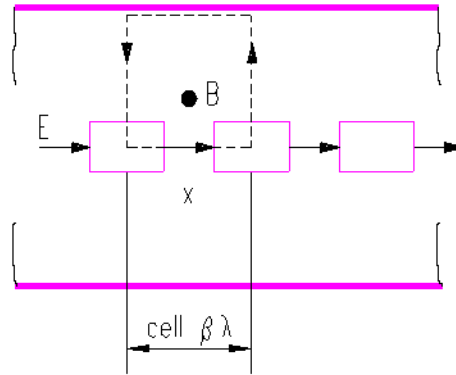

# Drift Tube Linac

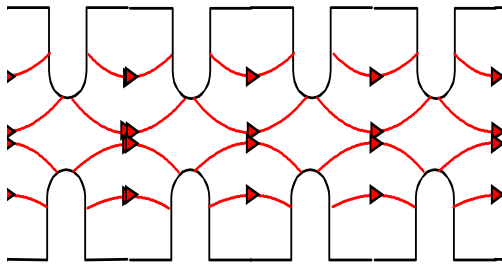

Disc loaded structure  
Operation in  $2\pi$  mode

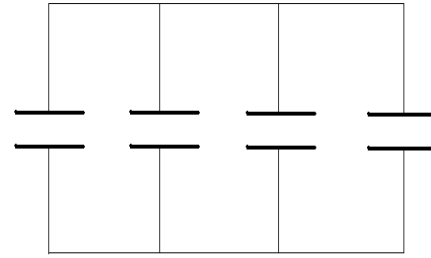

Add tubes for high  
shunt impedance

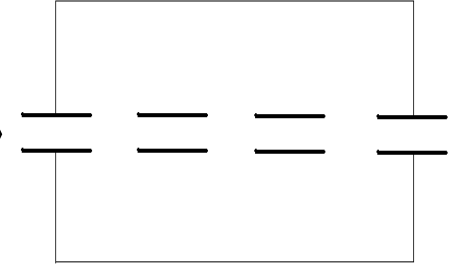

Remove the walls to increase  
coupling between cells

Particles are inside the tubes when the electric field is decelerating.

Quadrupole can fit inside the drift tubes.

$\beta=0.04-0.5$  (750 keV – 150 MeV)

Synchronism condition for  $2\pi$  mode : 
$$L = \frac{\beta c}{f} = \beta \lambda$$

Cell length should increase to account for the beta increase

**Ideal for low  $\beta$  – low W - high current**

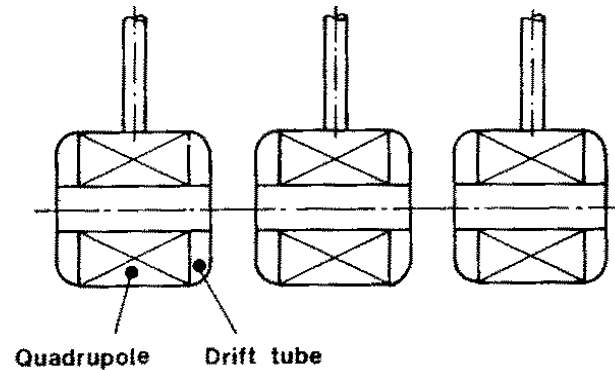

# Drift Tube Linac



CERN Linac2 DTL

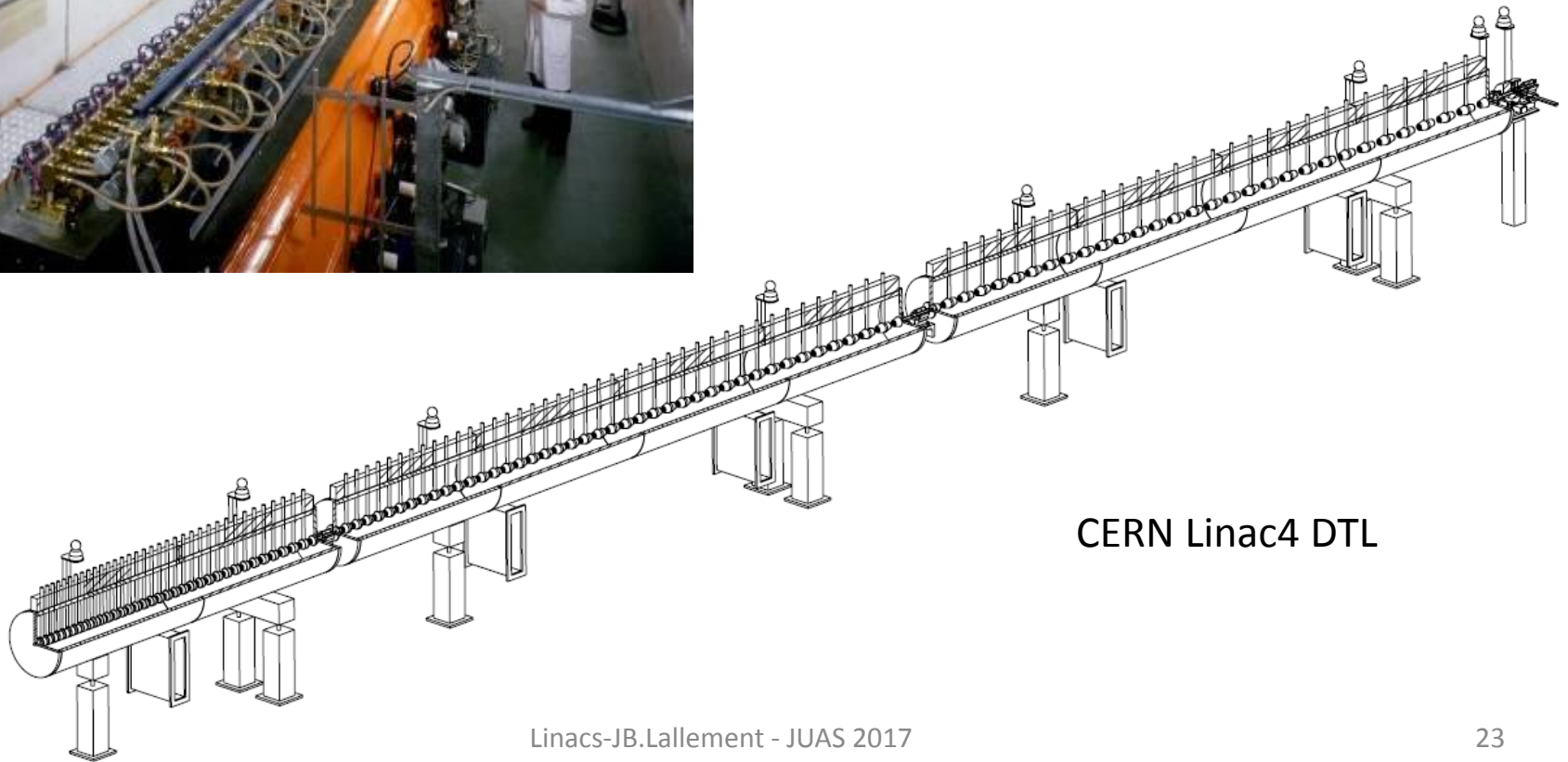

CERN Linac4 DTL

# Coupled Cavity DTL

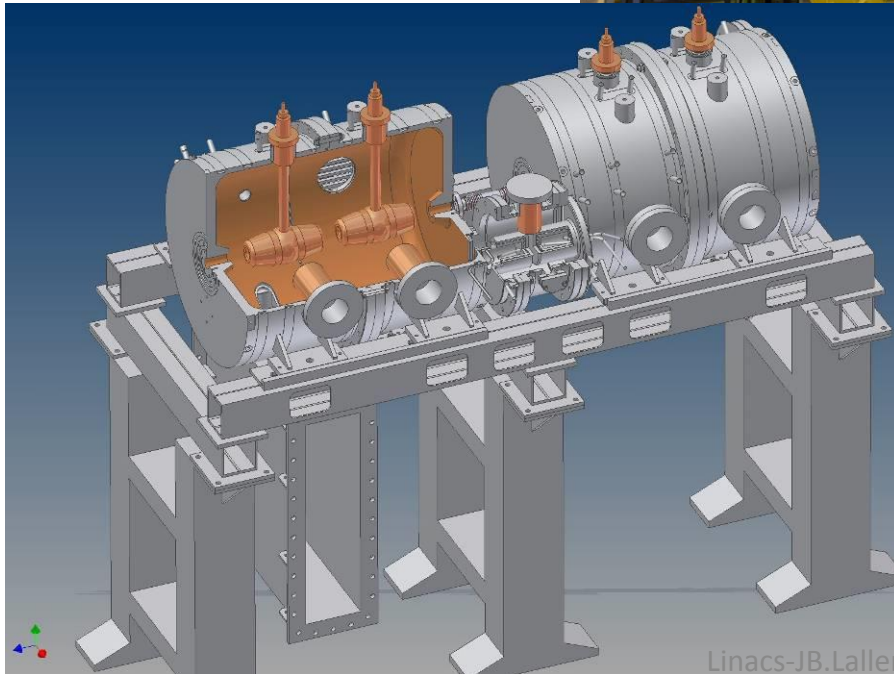
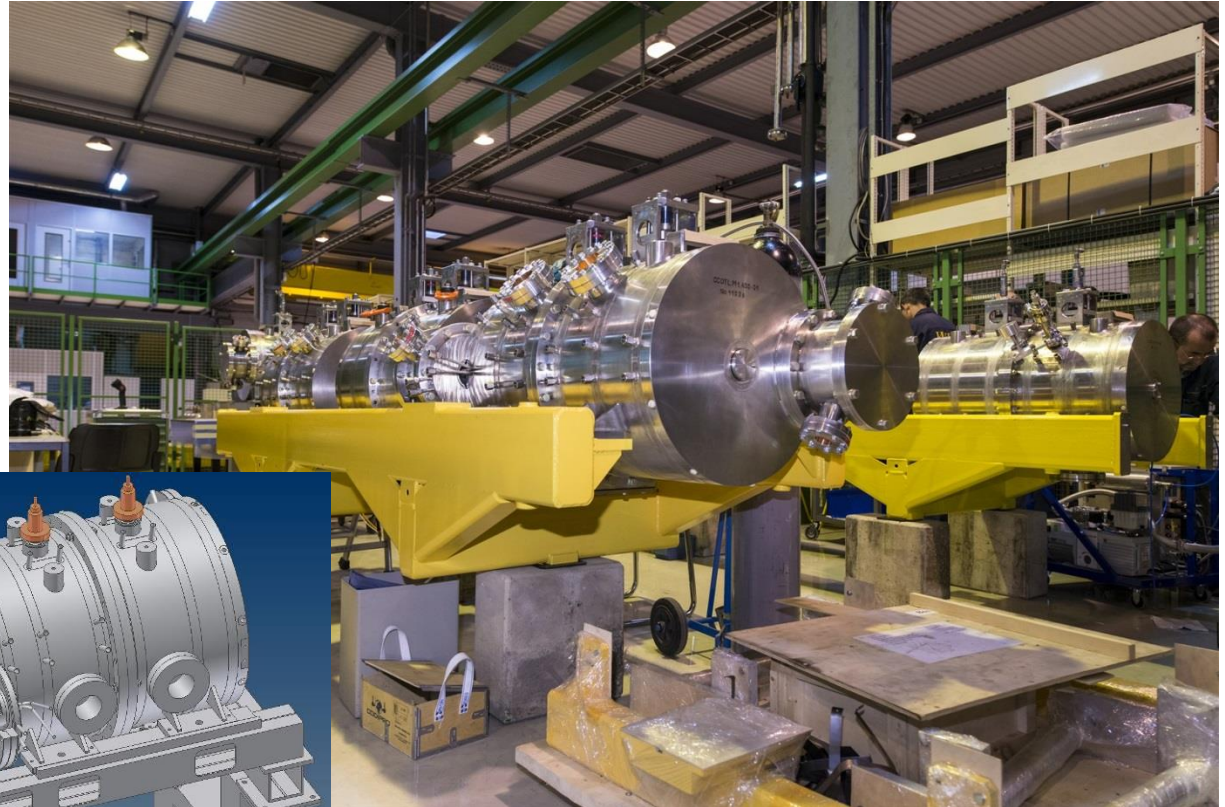



# Coupled Cavity DTL

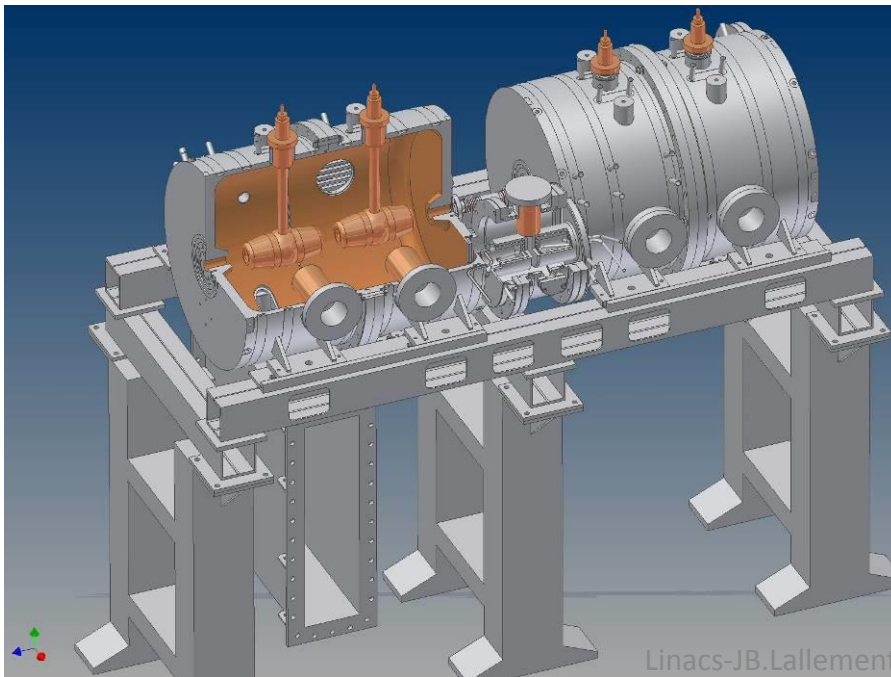
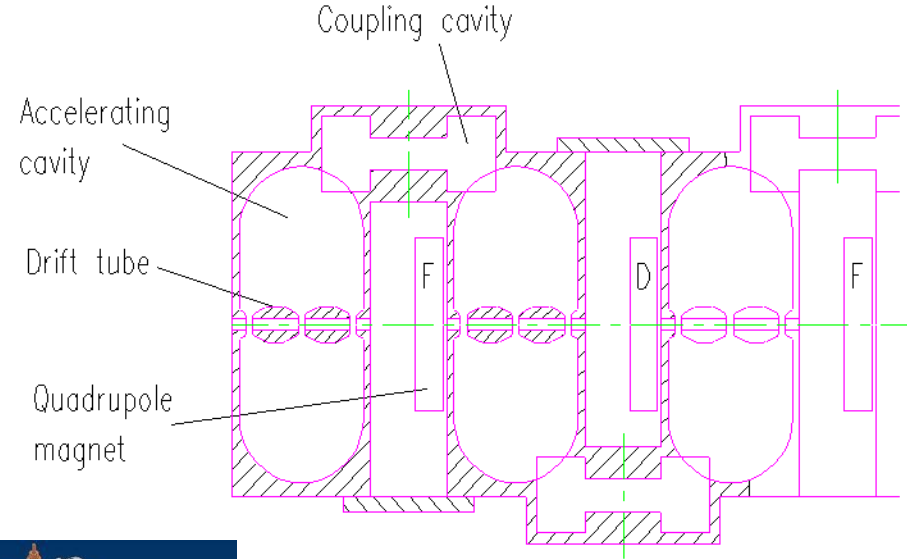

# Side Coupled Cavity

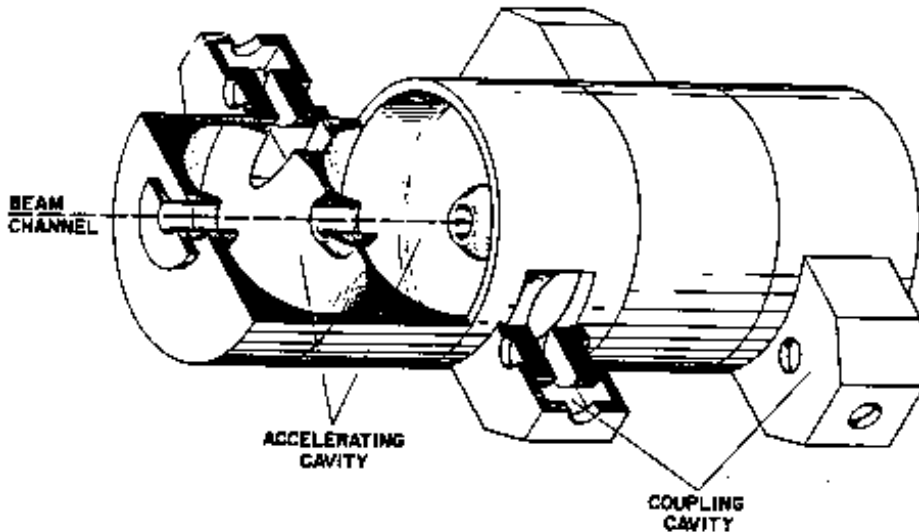

multi-cell Standing Wave structure in  **$p/2$  mode**  
frequency 800 - 3000 MHz  
for protons ( $b=0.5 - 1$ )

**Rationale:** high beta  $\Rightarrow$  cells are longer  $\Rightarrow$  advantage for high frequencies

- at high  $f$ , high power ( $> 1$  MW) klystrons available  $\Rightarrow$  long chains (many cells)
- long chains  $\Rightarrow$  high sensitivity to perturbations  $\Rightarrow$  operation in  $p/2$  mode

Side Coupled Structure:

- from the wave point of view,  $p/2$  mode
- from the beam point of view,  $p$  mode

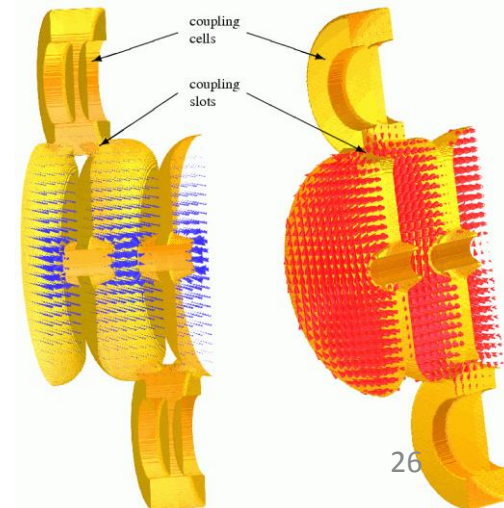

# Pi Mode Structure

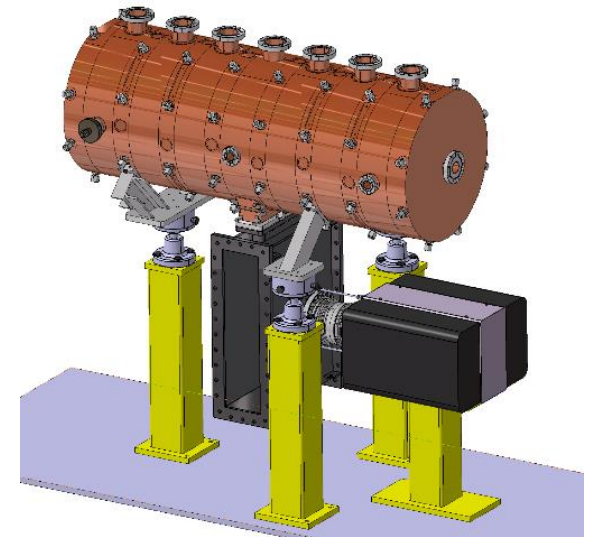
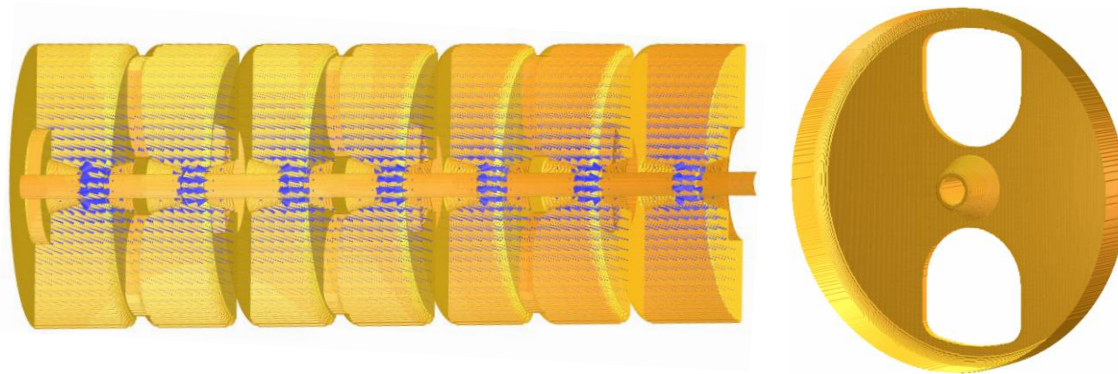
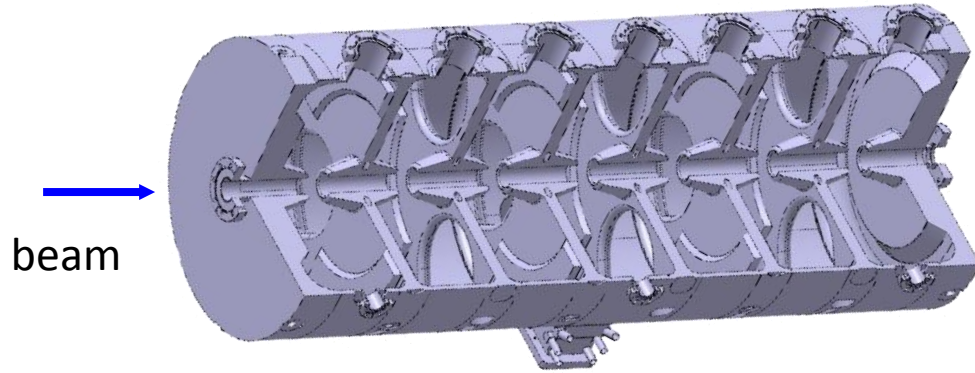

# Superconducting cavities

## Some examples



Multi gap cavities (elliptical)  
Operate in  $\pi$  mode  
 $\beta > 0.5 - 0.7$   
350-700 MHz (protons)  
0.35-3 GHz (electrons)

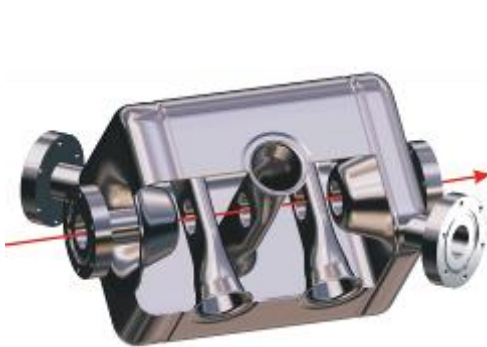

Other SC cavities (spoke, HWR, QWR)  
 $\beta > 0.1$   
From 1 to 4 gaps.  
Can be individually phased.  
Space for transverse focusing in between  
Ideal for low  $\beta$  - CW proton linacs.

# The choice of the structures

- Particle type : mass and charge
- Beam current
- Duty factor (pulsed, CW)
- Frequency
- Energy
- Operational constraints

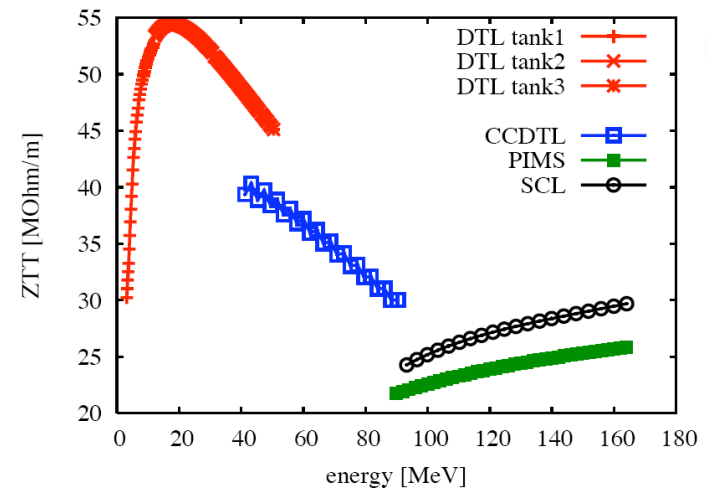

Cavity Type	Beta Range	Frequency	Particles
RFQ	Low! – 0.1	40-500 MHz	Protons, Ions
IH	0.02 – 0.08	40-100 MHz	Ions (Protons)
DTL	0.05 – 0.5	100-400 MHz	Protons, Ions
SCL	0.5 – 1 (ideal is 1)	600-3000 MHz	Protons, Electrons
HWR-QWR-Spokes	0.02-0.5	100-400 MHz	Protons, Ions
Elliptical	> 0.5-0.7	350 – 3000 MHz	Protons, Electrons

Not exhaustive list – To take with caution !!!



# The choice of the structures

- Particle type : mass and charge
- Beam current
- Duty factor (pulsed, CW)
- Frequency
- Energy
- Operational constraints

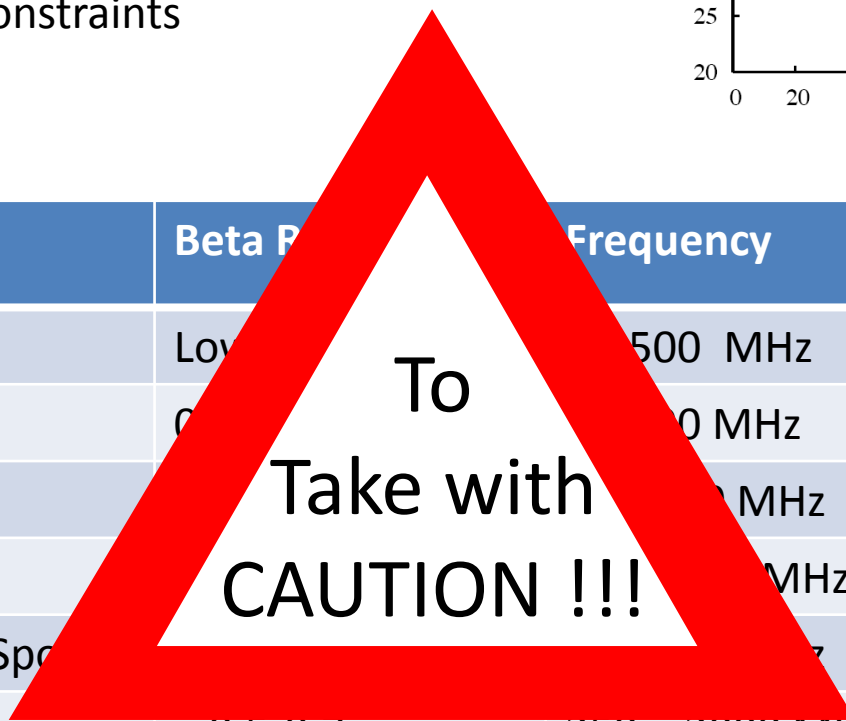
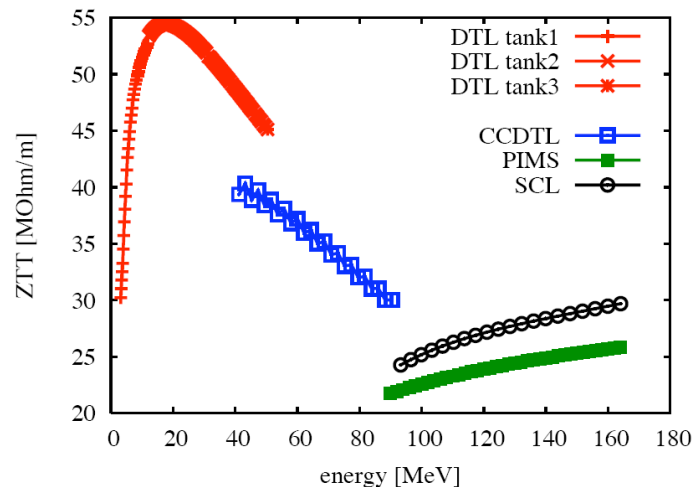

Cavity Type	Beta P	Frequency	Particles
RFQ	Low	500 MHz	Protons, Ions
IH	C	100 MHz	Ions (Protons)
DTL	0.5-0.7	100 MHz	Protons, Ions
SCL	> 0.5-0.7	100 MHz	Protons, Electrons
HWR-QWR-Spc	> 0.5-0.7	100 MHz	Protons, Ions
Elliptical	> 0.5-0.7	350 – 3000 MHz	Protons, Electrons

Not exhaustive list – To take with caution !!!