

Joint Universities Accelerator School

JUAS 2017

Archamps, France, 27th February – 3rd March 2017

Analytical & numerical design of a normal-conducting, iron-dominated electro-magnet

Case study – Tutorial – Mini Workshop

Thomas Zickler

CERN



Introduction

- The goal is to practice elements learned during the lectures
- Students are invited to design and specify a ,real‘ magnet
- Sample case: Bending magnet for the MedAustron medium-energy beam transfer line
- Work in groups of 3 persons during 2 half-days
- At the end, students are expected to deliver a written magnet design report



Programme



- Short introduction to MedAustron
- Magnet input parameters, requirements and constraints
- Exercise 1:
 - Analytical design (paper & pencil) to derive the main parameters
 - Expected results: detailed parameter list, magnet cross-section (yoke & coils) ready for entering the model in FE-code
- Exercise 2:
 - Numerical field computations and optimization of the pole profile
 - Expected results: optimized magnet cross-section (pole profile)



Introduction to MedAustron

MedAustron is located in Wiener Neustadt (50 km south of Vienna) next to the future site of the new hospital

Medical Treatment

- Tumour treatment
- Clinical research

Non-clinical Research (NCR)

- Medical Radiation Physics
- Radiation biology
- Experimental physics





Accelerator Main Parameters

- Synchrotron based (circumference 76 m)
- Ion species: protons and carbon ions
 - Optionally and at a later stage other ions with $q/m > 1/3$ are possible
- Energy range
 - Proton: 60-250 MeV (medical)
 - Higher proton energy provided for experimental physics: up to 800 MeV
 - Carbon: 120-400 MeV/n
- Cycle time > 1 second

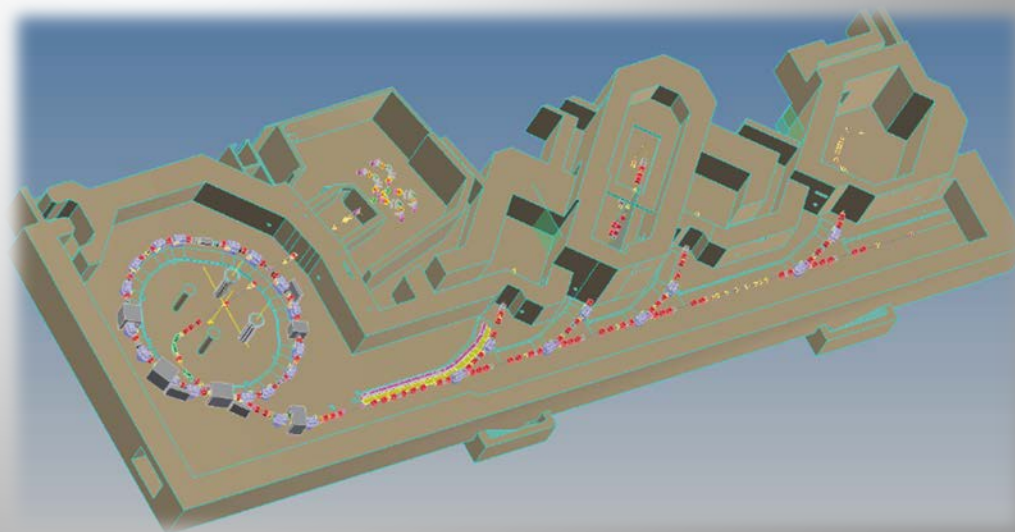



Irradiation rooms

Medical facility:

- IR2
 - Horizontal and vertical beam
 - Protons and carbon ions
- IR3
 - Horizontal beam
 - Protons and carbon ions
- IR4
 - Gantry
 - Protons

Non-clinical research facility:

- IR1
 - Horizontal beam line
 - Protons (up to 800 MeV) and carbon ions

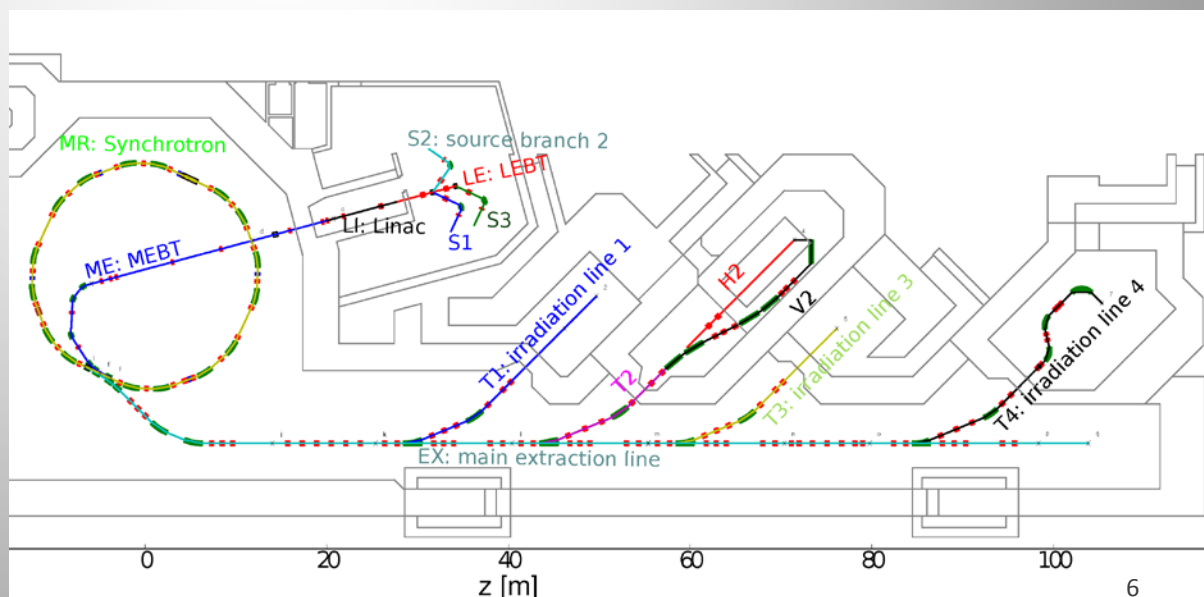



Magnet families

3 Spectrometers

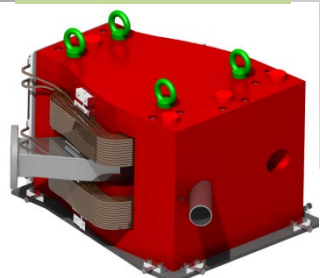

6 LEBT Triplets

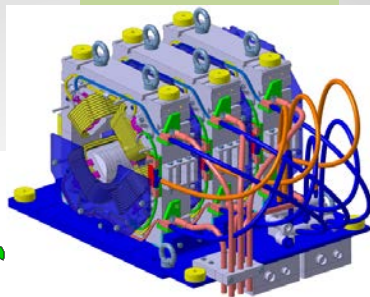

12 HEFT Dipoles

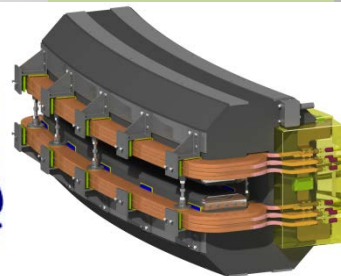

76 HEFT Quads

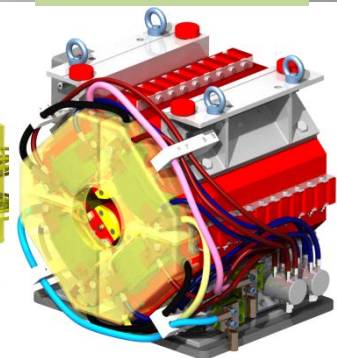

3 Solenoids

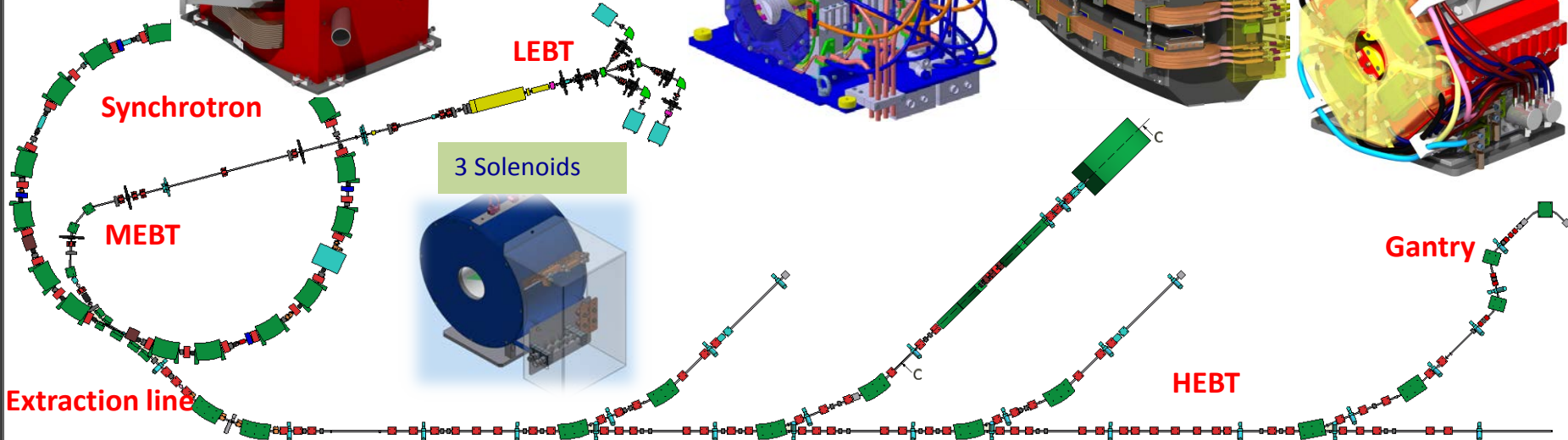
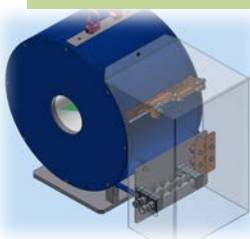

3 MEFT Dipoles

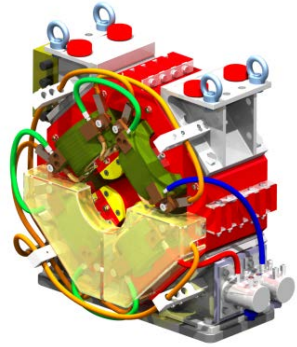

10 MEFT Quads

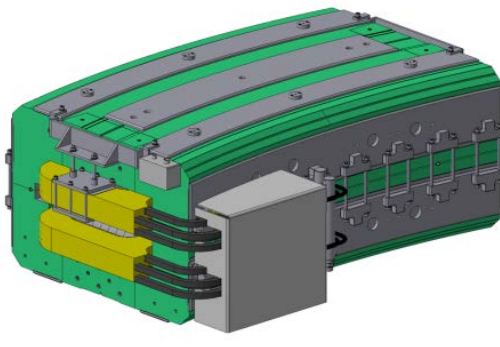

16 Ring Dipoles

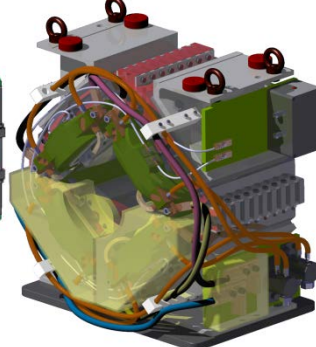

24 Ring Quads

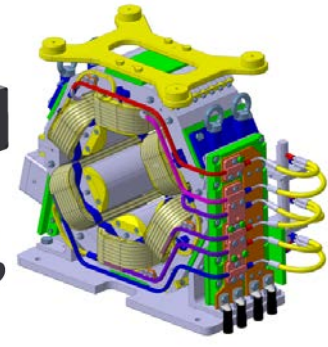

5 Ring Sextupoles



Beam parameters

Required: Three bending magnets for the medium-energy beam transfer line between the Linac and the Synchrotron

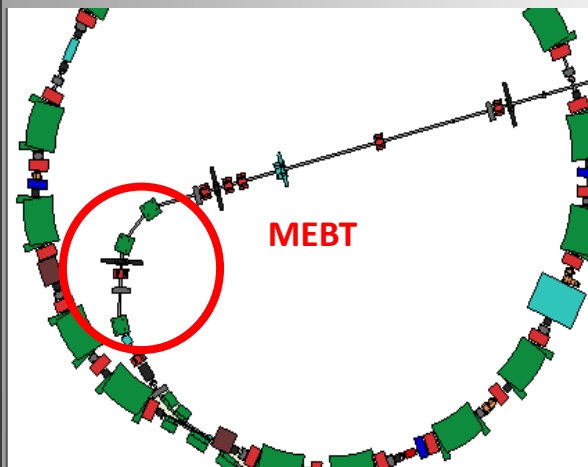

Parameter	Value	Unit
Particle type	Protons, C ⁶⁺	
Beam energy	7	MeV/u
Length of beam line	40.9	m
Beta function β_x, β_y	~10	m
Beam size σ_x, σ_y	+/- 10	mm
Margin for closed orbit distortions	+/- 10	mm



Functional specification

Parameter	Value	Unit
Number of magnets	3	
Bending angle	36	deg
Beam entry/exit angle	18	deg
Operation mode	quasi DC	
Ramp rate	0.3	T/s
Horizontal good field region	+/- 20	mm
Vertical good field region	+/- 23	mm
Field quality inside GFR $\Delta B/B_0$	$< +/- 1 \cdot 10^{-3}$	
Max. overall magnet length per magnet	0.8	m
Max. available water pressure drop	0.8	MPa
Inlet water temperature	25	°C
Max. converter current	650	A
Max. converter voltage (3 magnets in series)	160	V



Exercise 1: Analytical design

The following parameters should be defined or derived:

- Magnet shape (straight/curved)
- Flux density B
- Aperture height h
- Excitation current NI (ampere-turns)
- Magnetic length l_{mag} and iron length l_{iron} ($k = 0.55$)
- Pole width and yoke thickness
- Current density j , nominal current I and number of turns N
- Dissipated power P , coil resistance R , dc voltage V
- Coil size (width, height) and conductor material
- Pressure drop Δp , Temperature rise ΔT
- Conductor size (height, width, cooling hole diameter) and insulation thickness
- Coolant flow Q and flow velocity u_{avg} Reynolds number Re

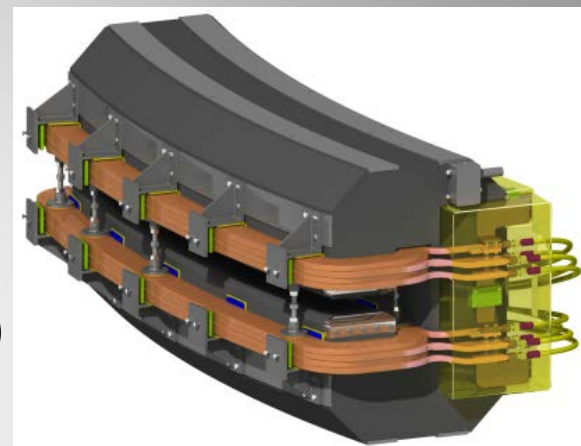



Exercise 1: Analytical design

For the computer work with FEMM, you will need the following magnet parameters:

- Aperture height
- Pole width
- Yoke dimensions (horizontal and vertical)
- Coil window width and height
- Coil dimensions (width and height)
- Coil position wrt to beam axis
- Coil excitation (ampere-turns)

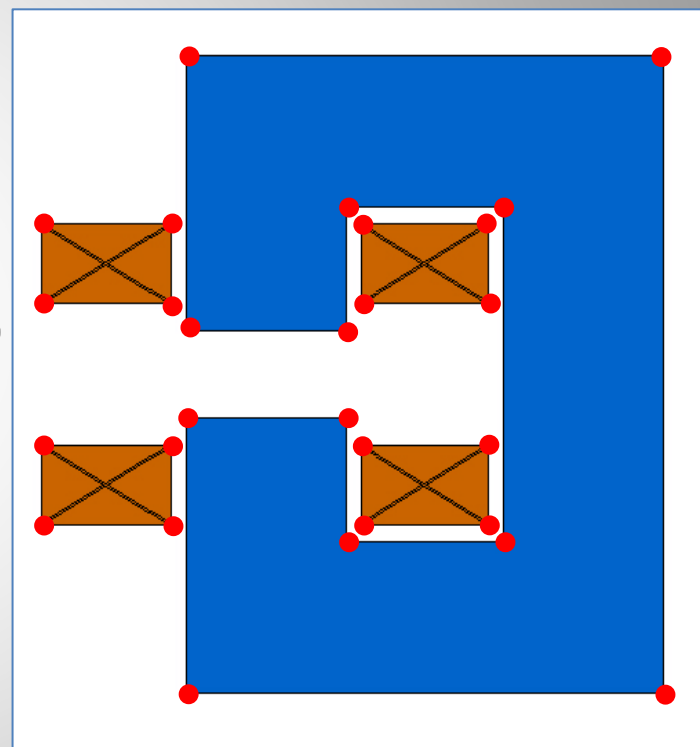

Hint: prepare a sketch with key-point coordinates



Exercise 2: Numerical design

2D Numerical calculations with FEMM:

- FEMM: 2D FE code for magnetics, electrostatic, heat flow and current flow problems with graphical pre- and post-processors
- Licensed under the terms of the [Aladdin Free Public License](#)
- Input via GUI or scripts (LUA scripting engine)
- More info (wiki) and download from the web:
- <http://www.femm.info/wiki/HomePage>



Exercise 2: Numerical design



The goal of this exercise is:

- Download, install and get familiar with FEMM (→ [homework](#))
- Enter a simple dipole geometry (yoke + coils) using nodes, segments and block labels
- Define and set the necessary material parameters
- Apply the correct boundary conditions
- Analyze the results:
 - field lines, flux distribution, central field, field along the axis and the GFR, current density, etc...
- Optimize the pole profile to improve the field quality



Design report

Students are expected to deliver a written magnet design report which should include at least:

- detailed magnet parameter list summarizing the outcome of the analytical design
- explanation for your design choice
- magnet cross-section based on analytical calculations with yoke and coil shape
- optimized cross-section (pole profile) based on numerical computations fulfilling the field quality requirements
- Note: the reports will be evaluated and contribute (3 points out of 20) to the total score together with the results of the exam
- Please send the final report (1 per group) in electronic form to the JUAS secretary
- Submission deadline: **Monday, 13th March 2017**