

Ideas on DC-DC Converters for Delivery of Low Voltage and High Currents for the SLHC / ILC Detector Electronics in Magnetic field and Radiation environments.

S. Dhawan ^a, D. Lynn ^b, H. Neal ^a, R. Sumner ^c, M. Weber ^d and R. Weber ^e

^a Yale University, New Haven, CT USA

^b Brookhaven National Laboratory, Upton, NY USA

^c CMCAMAC, 24 Halley Drive, Pomona, NY USA

^d Rutherford Appleton Laboratory, Chilton, Didcot, UK

^e Weber Technology, 5 Cogswell Road New Preston, CT USA

satish.dhawan@yale.edu

Abstract

For more efficient power transport to the electronics embedded inside large colliding beam detectors, we explore the feasibility of supplying 48 Volts DC and using local DC-DC conversion to 2 V (or lower, depending upon on the lithography of the embedded electronics) using switch mode regulators located very close to the front end electronics. These devices will be exposed to high radiation and high magnetic fields, 10 – 100 Mrads and 2 - 4 Tesla at the SLHC, and 20 Krads and 6 Tesla at the ILC.

I. INTRODUCTION

We have been involved with the ATLAS and CMS detector construction at CERN. Yale designed and constructed the low voltage regulator cards for the ECAL of CMS (see fig. 1). The 3,100 low voltage regulator cards that we constructed each deliver 16 amps at 2.5 volts to the front-end CMOS chips. The total current drawn by the cards is 50 Kamps. The power supplies are located 30 meters away on the magnet yoke and supply 6.3 volts. After a loss of 1 Volt in each leg of the power cable, the regulator card input is 4.3 volts. The required voltage across the regulators (LHC4913 made by S.T. Microelectronics) is 1.8 volts for the minimum dropout voltage needed after 10 years of exposure to the radiation. These are linear regulators and are insensitive to the high magnetic field. They have low power efficiency but also have low output noise and low EMI. Figure 1 is a layout of the DC powering system to emphasize the low efficiency of delivering power to the detector (in this case, only 40%, 2.5/6.3).

For the International Linear Collider (ILC), the Silicon Detector (SiD) will require 50 Kamps. The CALICE detector at the ILC requires 300 Kamps. The feature size of the front end silicon is migrating towards 65 nanometers, and in the future will operate with higher currents at less than 1 volt.

To us, the only feasible alternative power delivery system requires DC-DC switching converters. These can have very high power efficiencies of up to 95%. If we could supply 48 Volts and the local regulators convert it to 2 volts for the chips, the result would be a x24 reduction in the supply current and at least a x24 reduction in conductor (copper or Aluminum) cross section. Smaller conductor cross section will result in less dead material in the detector, less multiple scattering and possibly an increase in the detector coverage.

The power dissipation in the power delivery system (which also must be removed by the cooling system) will be lower due to the high conversion efficiency of the DC-DC switching regulators and the lower currents in the supply cables. The main challenges are the radiation and the magnetic field. We must have radiation hardening of the semiconductors in the DC-DC regulator, the controller ASIC and the MOSFET switches. There are many groups who are experts in this field and we intend to utilize their expertise. The other challenge is the operation in the high magnetic field that we shall address in this paper. The inductors usually used in DC-DC converters are made with a ferrite core, and are not suitable for high magnetic fields. In 2005, we became aware of the work of Intel Corporation in integrating air core inductors on their 90 nanometer CPU chips [1-3]. By using higher switching frequency, air core coils can replace the ferrite coils usually used in switching DC – DC converters. Their exploratory work tested operation at up to 480 MHz. There was an attempt made at NIKEF to use air core coils for the Atlas detector but it was not successful [4].

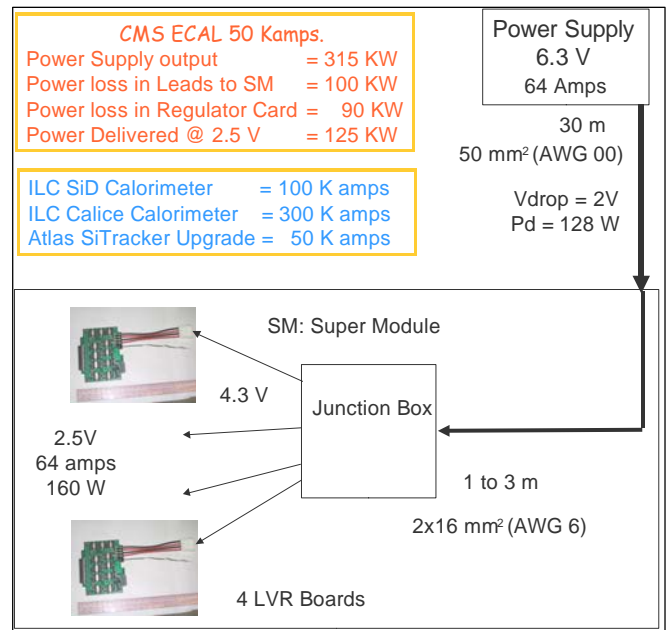

Figure 1: ECAL Power Distribution

II. OVERVIEW OF EXISTING TECHNOLOGIES

Let us look at some DC-DC converter technologies currently in use (Charge pump, switch mode and resonant switch converters):

A. Charge pump

A charge pump charges several capacitors in series to the input supply voltage and then connects them in parallel across the load. The input to output voltage ratio is given by the number of capacitors. It is usually limited to small (< 1 ampere) currents but can provide negative voltages.

B. Switch Mode: Synchronous Rectification.

A switched-mode power supply (SMPS), is an electronic power supply unit that incorporates a switching regulator (a control circuit that switches the current rapidly on and off) to regulate the output voltage. This is the most common technique being used for single chip implementations with either internal or external MOSFET switches. PWM (pulse width modulation) is used to translate high input voltage to low output voltage by pumping current into an inductor with shorter ON times and longer OFF times.

Switching regulators are used as replacements for linear regulators when higher efficiency, smaller size or lighter weight is required. They were, however, more complicated and more expensive, and their switching currents can cause EMI and noise problems if not carefully designed. Power converters are becoming increasingly commonplace in the electrical industry. Product manufacturers and suppliers of electrical equipment are demanding ever-increasing performance (i.e., higher efficiencies, lower output voltages, higher currents, faster transient response) from their power supply systems. To meet these demands, switching power supply designers in the late 1990s began adopting Synchronous Rectification (SR) using MOSFETs to achieve the rectification function previously performed by diodes. SR improves efficiency, thermal performance, power density, manufacturability, and reliability, and decreases the overall system cost of power supply systems.

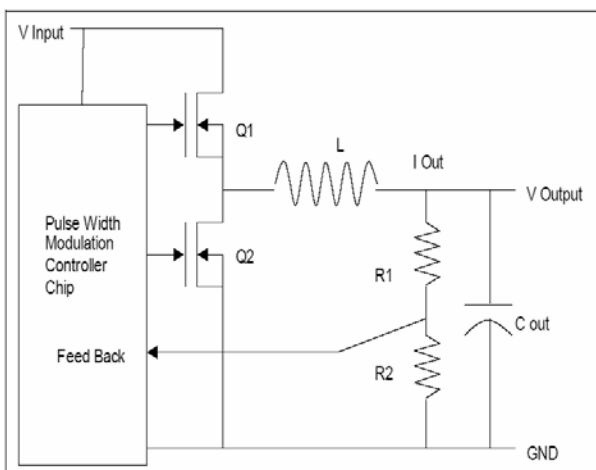

Figure 2: Synchronous Rectification

Referencing Figure 2, when Q1 is switched ON, current into the load increases and energy is stored in L. When Q1 is

switched OFF, Q2 is switched ON providing a current path to allow energy stored in L to be transferred to the load. A simple power rectifier may be used in place of Q2 (as a *catch* or *flyback* diode) but the forward voltage drop of a Schottky power diode will cause an efficiency loss. When a MOSFET is used as a synchronous rectifier in this topology, the controller chip must carefully control the switching of Q1 and Q2 to prevent shoot-through – i.e. an overlap of the ON times of Q1 and Q2 that can momentarily short the input power.

In DC-DC Converters, the average DC output voltage must be controlled to be equal to a desired level though the input voltage and output current may fluctuate. Switch mode DC-DC converters utilize one or more switches and an inductor to transform DC from one level to another. Generally the controllers work at a fixed frequency to make it easier to filter the output ripple. In Figure 2., Q1 and Q2 are turned on in a sequence to connect the inductor input to the input voltage or to ground. The duty cycle is determined by the ratio of the Output / Input voltage. A feed back from the output adjusts the duty cycle to keep the output voltage at the specified level. Typically, DC current always flows through the inductor (continuous conduction mode)

When Q2 is replaced by a Schottky diode it is called a non-Synchronous Rectification. The diode keeps the current in the inductor flowing when the MOSFET is off. There is more power lost in the diode since the forward voltage is much larger than the voltage across the MOSFET when it is conducting.

C. Resonant Switch Converters

In certain switch-mode converter topologies [6], an LC resonant circuit can be used to shape the switch voltage and current to change the power factor seen by the switch. This allows zero-voltage and / or zero-current switching. In such resonant-switch converters, during one switching-frequency time period, there are resonant as well as non-resonant operating intervals. Circuits with inductors and capacitors are used at or near resonance for transforming power to high voltages or higher currents. Class-E RF amplifiers can convert DC to RF at very high efficiencies.[5] and then synchronous rectification for DC output. Therefore, these converters in the literature have also been termed quasi-resonant converters.

They can be sub-classified as follows:

- (a) Zero-current-switching (ZCS) converters
- (b) Zero-voltage-switching (ZVS) converters

Vicor Corporation [7] is the leader in making Quasi resonant high density DC-DC converter modules. This is shown in Figure 3. Their VTM /BCM power train has dual H bridges and extensive use of transformers to adjust the input to output voltage transformation. The input voltage range is 38-54 volts, and modules are available with output voltages from 0.8 to 54 V. The match box size hybrid module delivers 200 watts with current up to 100 amps. The efficiency is greater than 94%. Vicor has one ASIC controller chip, one power transformer T1, and gate driver transformer T2. The circuit Q is about 10 and they use proprietary techniques to achieve both ZCS and ZVS as shown in figure 4..

III. POWERING OF SILICON TRACKERS

We look at the problem of powering the Silicon trackers in SLHC and ILC detectors. Figure 5 shows a prototype “stave” mounted with six $4 \times 6 \text{ cm}^2$ silicon sensors. Each sensor is read out by a multi-chip module containing four custom readout chips. All control signals and power to the modules are routed via Kapton flex circuits. Such modules may draw as much as 4 amps at 1.3 volts. Staves may contain 10-40 modules depending upon the required acceptance. We’ll consider a 10 module stave that requires 40 amps of current.

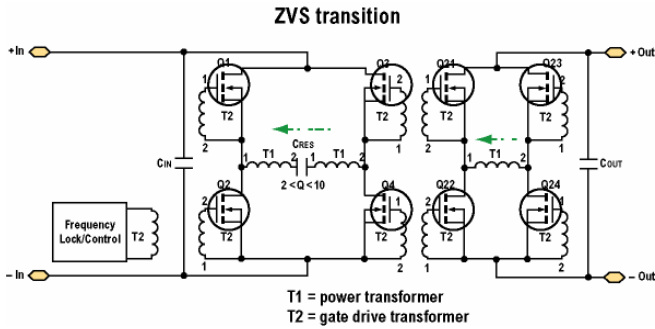

Figure 3: Vicor VTM circuit.

The Vicor VTM has no regulation circuitry in it. A 1% change in input appears at 1% change in the output voltage. This may be adequate for HEP applications if the 48 V power supply has remote sense capability and is well regulated. For other applications a pre regulator called PRM containing a buck boost regulator delivers 48 volts to the VTM from a 36-75 volt unregulated source.



Figure 5: Stave with 6 sensors and the hybrid card.

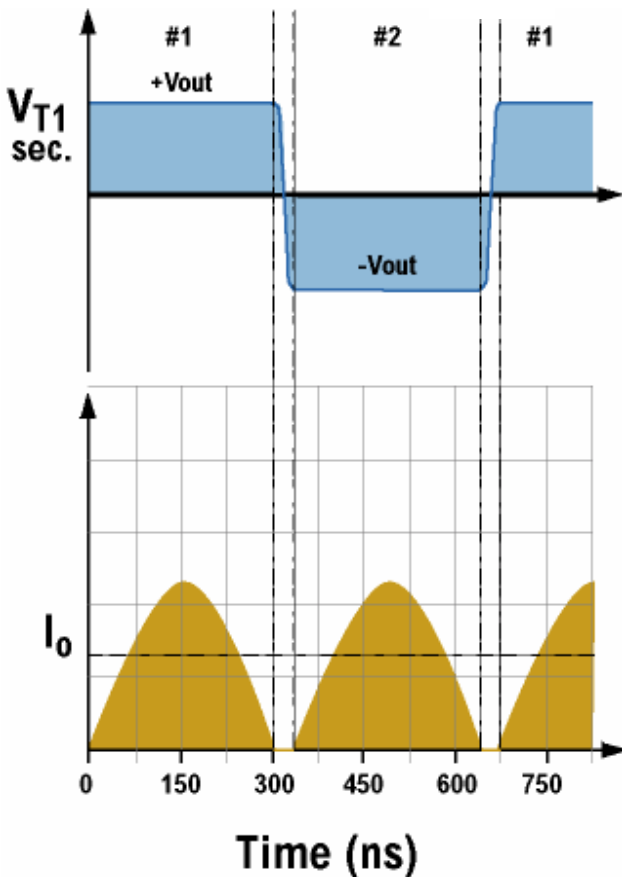

Figure 4: Vicor VTM circuit operation.

Our objective here is to focus on a relatively high supply voltage (48 V) with output currents in the range of 2 – 50 amps. This work is limited to using only air core coils.

A. Two power schemes with DC-DC converters are possible;

Four Amp DC-DC converters are mounted on each module. 48 volts are delivered to each module in parallel via Kapton traces.

Forty Amp converters are mounted at or near the end of each stave. Here the Kapton power and ground traces carry increasingly more current towards the supply end of the stave

For this exercise we assume that the SLHC and ILC requirements are somewhat similar but there are some differences.

Four Amp converter units are located near the front end and may be exposed to $> 30 \text{ Mrads}$ of radiation in the SLHC, but only 20 Krads at the ILC. The units should be made of low density materials. It may be possible to integrate the FETs on the ASIC.

Forty Amp units can be located in a off-detector service area with lower radiation exposure for both the SLHC and ILC.

SLHC needs the power to be on continuously and that adequate cooling be provided. In the ILC, the power can be switched on for the brief time when the beams are colliding. Here the duty cycle is 0.5% and the cooling solutions are simpler than for the SLHC. We ignore the Lorentz force problem in switching current in the ILC. It may be necessary to provide slow current cycling.

SLHC detectors use lower magnetic fields while the ILC detector is being designed for 6 Tesla. The converters have to be designed to run in a field from 1 to 6 Tesla.

IV. POWER CONVERTER DESIGN ISSUES

The critical components are the ASIC controller chip, MOSFETs and the air coils. These are some of the issues that need to be explored:

MOSFET radiation hardness for 48 Volt silicon processes may be difficult (or impossible) for SLHC but achievable for the ILC.

It may be possible to use air core transformers to reduce the voltages to be handled by the ASIC and the FETs. There is a tradeoff between voltage and current handled by the FETs for the same output power level. The higher switching frequency requires smaller inductor values that are more easily satisfied with air cores. The noise at the output is tens of millivolts and substantially more at the input supply rail.

The Vicor units are in a different class due to the use of Quasi-resonance and sine waves. The output noise and ripple are very low. A test done at BNL indicated no obvious degradation of low noise preamplifiers

V. TEST RESULTS WITH AN AIR CORE INDUCTOR

We are now concentrating on using air core inductors with existing DC-DC converter chips. Most of the available controllers operate at less than 500 KHz, but there are a few operating at several MHz with a smaller inductor. We tested the following controller chips using company supplied evaluation boards, replacing the ferrite inductor with an air core inductor.

Texas Instruments TI 5430: Operating frequency is 500 KHz. Input range is 5.5 to 36V. Minimum output is 1.22 V. The evaluation board is set for 5 V. Output is rated at 3 amps. We tested by switching 2 amp loads.

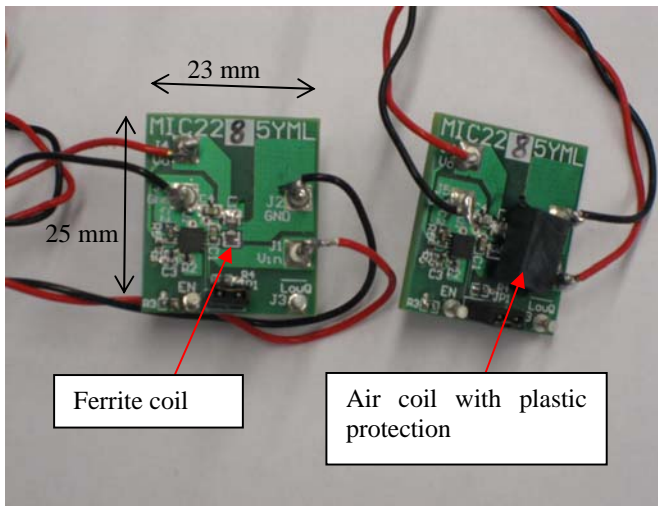

Figure 6: Photograph of Micrel with Ferrite (left) and Air Coil (right).

Micrel MIC2285: Operating frequency is 8 MHz using a 0.47 μH inductor. Input range is 2.7 – 5.5 V@ 0.5 amps output load.

Linear Technology LTC3415: Operating frequency is 1.5 MHz. using a 0.2 μH inductor. Input range 2.25 to 5.5V. Output spans 1.8 – 3.5V @ 7 amps. The evaluation board is preset for 1.8 V, and we tested by switching 6 amp loads.

The results are shown in table 1. The low inductance air coils are made by Coilcraft Corp. with a maximum inductance of 0.538 μH . At Yale, we wound 6.25 mm diameter solenoid with AWG22 magnet wire; a 40 turn coil has inductance of 5.9 μH , while 30 turns give 2.8 μH .

The load was a Datel active load with a maximum rating of 20 amps. The duty cycle was about 20% and we did not need to provide any cooling.

There were no special filters used except what was on the evaluation boards. The ripple and noise can be much reduced by using standard filters for the low noise amplifiers.

There were 2 Micrel evaluation boards, the air coil was mounted on one board. The TI board had a large ferrite core, so we decided to put the air coil in parallel. The resultant inductance is mainly from an air coil.

The Vicor board results is shown for comparison with the LVRB load as shown in figure 1. The output and input and output ripple signals are shown in figure 8. The 48 Volt power supply did not power output for more than a 24 amp load.

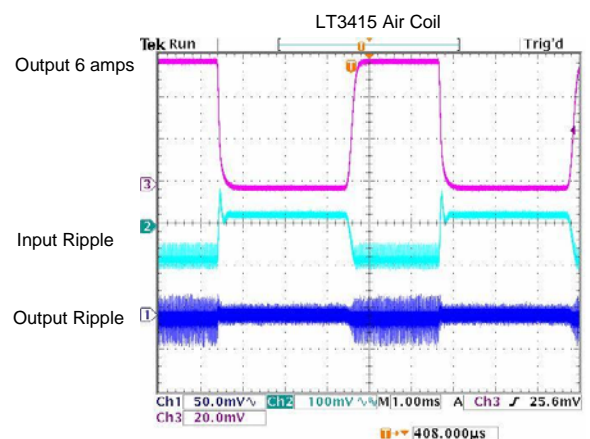
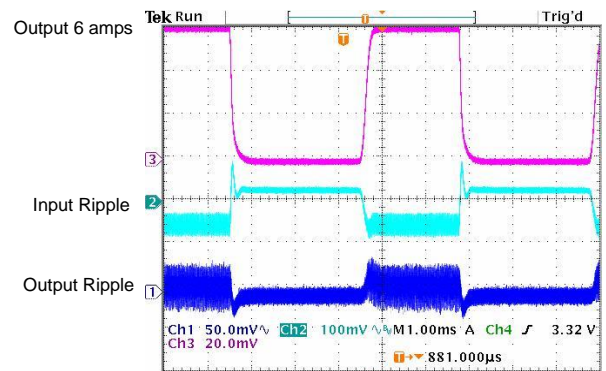

Figure 7: Comparison of the LT3415 DC-DC converter chip with the ferrite coil versus the air coil.

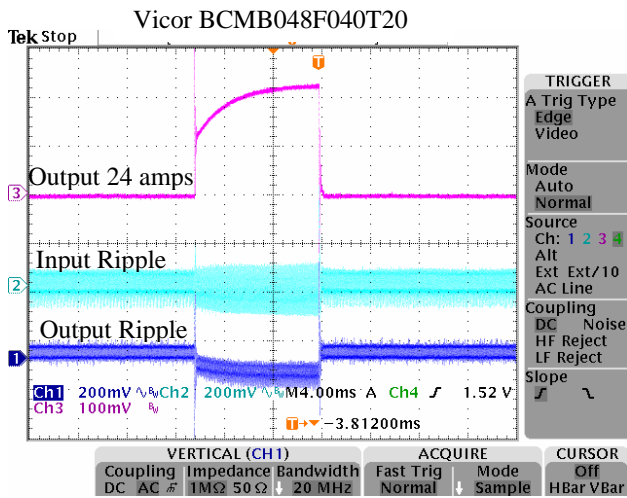

Figure 8: Results for the Vicor multi chip hybrid with ferrite based transformers.

VI. CONCLUSIONS

In conclusion, there is no difference between the ferrite and air coils if the inductance is the same. This can be seen in figure 7 with LT3415. The noise is increased if a lower inductor value is substituted.

Vicor match box size module is a good candidate for delivering 2 Volts at up to 100 amps. It is a multi chip hybrid with ferrite based transformers. The ASIC in it now can withstand 20 krads. It is feasible to design air core transformers if the operating frequency is increased by a factor of 10 to 15 MHz. Needless to say, there are many challenging problems to overcome.

We are very encouraged by the tests with the air coils using standard switch mode controller chips. For better operations (noise, efficiency, EMI shielding etc.) in the magnetic field the switching frequency should be an order of magnitude higher. We would like to encourage other groups to work with us on pursuing this development.

VII. ACKNOWLEDGEMENTS

We thank the following companies for supplying us their evaluations boards and samples at no charge, Vicor Corporation, Micrel Inc and Linear Technology Corporation.

VIII. REFERENCES

- 1: Peter Hazucha et al: pages 838-845 IEEE Journal of Solid State Circuits, Vol. 40. NO. 4. April 2005.
- 2: Gerhard Schrom et al: pages 4702-4707 2004 35th Annual IEEE Power Electronics Specialists Conference.
- 3: Gerhard Schrom et al: pages 263-268 Proceedings of the 2004 International Symposium on Low Power Electronics and Design (ISLPED '04)
- 4: Sander Mos [sander.mos@nikhef.nl] Zero Iron Power Supply <http://www.nikhef.nl/~sander/m/ziips/index.html>
- 5: Private Communication Nathan O. Sokal, Design Automation Inc, 4 Tyler Road, Lexington, MA, 02420, USA
- 6: Power Electronics 3rd edition authors Mohan, Underland, Robbins. John Wiley & Sons Inc. ISBN 0-471-22693-9
- 7: Vicor Corporation, Andover, MA, USA

Table 1. Test Results

Devices Tested	Specifications					Coil Inductance			Ripple with Ferrite Coil		Ripple with Air Coil	
	Manufacturer	Device #	Input Range V	I _{out} amps	Freq. MHz	V _{out}	Ferrite Coil μH	Air Coil μH	Pulsed Load Amps	In mV	Out mV	In mV
Linear Technology	LTC3415	2.25 – 5.5	7	1.5	1.8	0.2	0.169	6	60	40	60	40
Micrel	MIC2285	2.7 – 5.5	0.5	8	1.8	0.47	0.538	0.5	10	70	25	80
Texas Instruments	TPS5430	5.5 – 36	3	0.5	5	18	5.9	2	80	180	120	200
							2.8	2			250	240
						<i>air coil in parallel with ferrite coil</i>						
Vicor	B048 F040T20	38-55	58		4			24	220	100		

Inductance	Coil Specifications
0.169 μH	Coilcraft Part Number 132-20SM
0.538 μH	Coilcraft Part Number 132-12SM
5.9 μH	Yale 6.25 mm diameter 40 turn Solenoid
2.8 μH	Yale 6.25 mm diameter 40 turn Solenoid