

Integration of CMS Tracker Optical Links

K. Gill, S. Dris, R. Grabit, I. Pedraza, D. Ricci, J. Troska and F. Vasey

CERN, 1211 Geneva 23, Switzerland

karl.gill@cern.ch

Abstract

The world's largest point-to-point optical link system is being developed at CERN for readout and control of the CMS Tracker. The optical links are currently being integrated into the Tracker sub-detector systems and preparations are underway for final cabling and connection of the Tracker in CMS at LHC Point 5. Development was recently completed on the dense, in-line optical patch-panel in addition to the back-end patch-panel. Quality assurance and quality control procedures related to cabling and connections, acceptance tests, and tests of final system performance have been defined and practiced. The recent experience during sub-detector integration and the CMS Magnet Test Cosmic Challenge is described.

I. INTRODUCTION

The installation of the largest and densest fibre optic system in any of the LHC applications is now underway. 41000 analogue optical links and 3000 digital optical links will be used for readout and control of the CMS Silicon Strip Tracker system[1,2]. These two systems are illustrated together schematically in Fig. 1.

Both sets of optical links are based on commercial off-the-shelf parts including 1310nm edge-emitting lasers, InGaAs photodiodes and single-mode fibre-optic cables with standard connectors in custom in-line and back-end patch-panels. The active components are integrated onto compact optohybrids at the front-end and into VME (FED and FEC)[1] cards at the back-end. The cabling includes single-fibre, 12-way ribbon and 8x12 multi-ribbon cables going from the front-end to the back-end respectively. All parts inside CMS have been qualified for reliability and radiation hardness[2]. Each optical link is typically 65m long, spanning between the Tracker in the CMS experimental cavern (UXC55) and the counting room in the adjacent cavern (USC55) at LHC Point 5, as in Fig. 2. There are three patch-panels for the fibre connections: one at the front-end, close to the optohybrids, a second very dense, in-line patch-panel just within the CMS magnet coil, and the final connection point at the back-end racks.

Production of all of the optical link parts is now complete[3], including 5-10% spares across the whole system. Many parts have been already distributed and integration of the front-end parts in particular is nearing completion. The remaining work involves mainly the installation of in-line and back-end patch-panels, then cabling and connections and commissioning of the full system. In the following sections we will describe the experience gained so far during subdetector integration, the CMS Magnet Test/Cosmic Challenge (MTCC), and future plans for the final integration of optical links in CMS at Point 5.

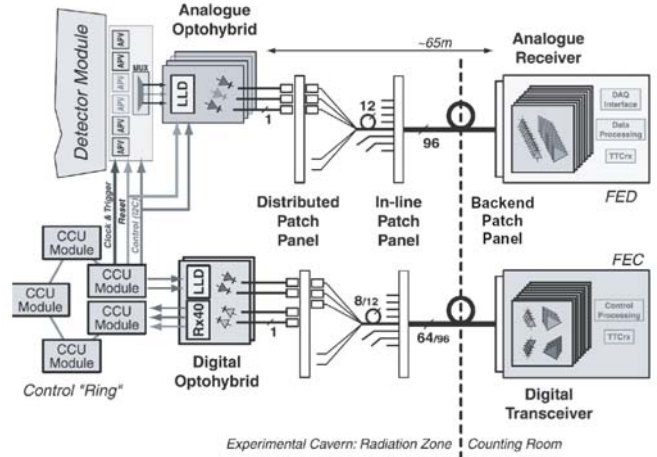

Figure 1: Analogue (uppermost) and digital (lowermost) optical link systems for readout and control of the CMS Tracker.

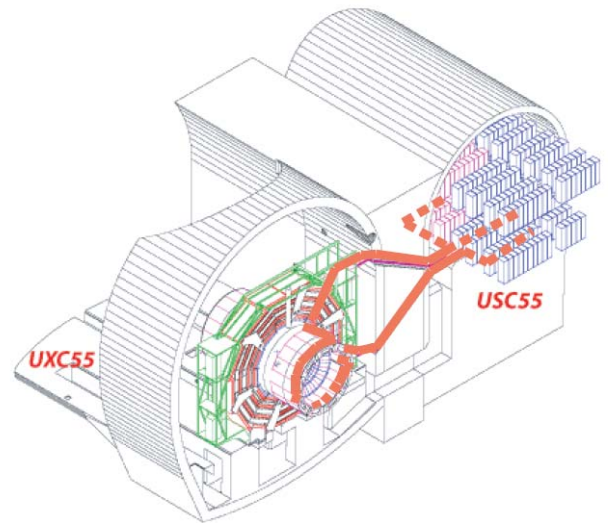

Figure 2: Examples of Tracker optical link cable paths between PP1 sectors on the CMS central barrel wheel (YB0) in the experimental cavern (UXC55) and the back-end racks in the service cavern (USC55) at LHC Point 5.

II. SUB-DETECTOR INTEGRATION ACTIVITY

Analogue and digital optohybrids have been installed in the sub-detectors very close to the silicon detector modules. i.e. the 'strings' in the Inner Barrel/Inner Disks (TIB/TID), 'rods' in the Outer Barrel (TOB), and 'petals' in the Endcap (TEC). The fibres have then been routed carefully to the edge of the given support-structure (e.g. barrel layer or disk) where the distributed patch-panel is located. The optohybrids have

been manufactured with a spectrum of fibre lengths to match the intended routing in cases where the path lengths were calculable in advance, e.g. in TOB and TEC there are 35-120cm fibre pigtails. TIB/TID fibre route lengths were, in contrast, not calculated in advance and all TIB/TID optohybrids were made with 2m long fibre pigtails. The slack management has since presented a difficult and lengthy challenge for TIB/TID subdetector integration, requiring very careful routing of the slack fibre on the mechanical structures.

Tests have been made in all subdetectors to check that the installed optohybrids function correctly. A commissioning procedure was prepared for the optical links that uses the output, in particular the synchronization pulses (known as ‘ticks’), from the front-end microstrip detector APV[1] readout chips to drive a known-size signal into a given optical link. The optical output is then collected using a fibre ribbon cable, or multi-ribbon cable, connected to either a purpose-built DAQ system or a small slice of the final CMS Tracker DAQ. Fig. 3 shows an example of an analysis of analogue optohybrid performance, in terms of measured APV tick-size for different laser driver gain settings. These data were from burn-in tests of the TIB. The data matches very well the expected gain distribution of the optical link[4], also illustrated in Fig. 3. This was also the case in integration tests in the other Tracker sub-systems. Optohybrid channels with gain outside the expected ranges[4] were identified and investigated. This occurred typically in ~1% of channels, always with lower than expected gain. In these cases, the optical connections were re-cleaned and the gains re-measured. Re-cleaning the connectors resulted in proper functionality in almost all cases, except where a fibre had been broken during installation.

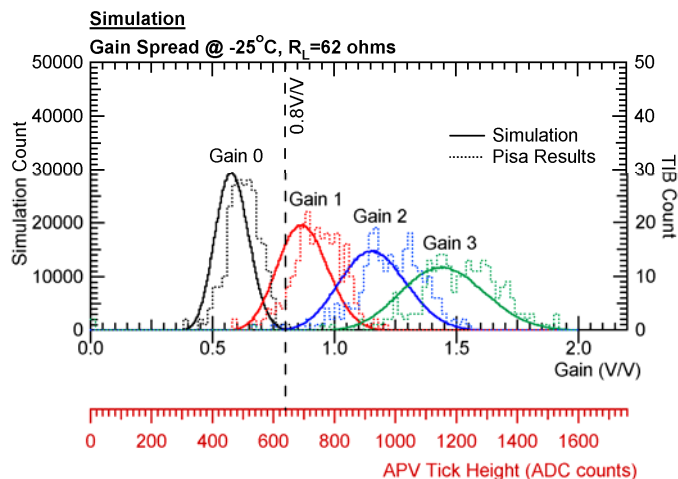

Figure 3: Optical link output for analogue optohybrids having different laser driver gain settings. Data is from TIB/Pisa burn-in tests. Also shown is the simulated optical link performance based on production test data for the various optical link sub-components[4].

Tests have also been made, for example during TIB/TID integration, to check the optical ribbon fanout continuity after installation (but before connection). This was done usually by illuminating the 12-channel MFS connector with a multiple red-LED light source (that makes no physical contact with the optical fibres) and checking for emergent red-light at the distributed patch-panel. The sMU-MU connection there

between ribbon fanout and optohybrid was then made after the MU-connectors were all cleaned with a reel cleaner. The sMU connectors however were only cleaned if the ribbon had been used previously or if it was suspected that the connection was dirty or faulty, based on the results of a measurement. Following connection of the fanout/ribbon to the optohybrids, the performance of the optical link was checked again, usually with a slice of the DAQ system, as with the tests done earlier for the optohybrids only.

The ribbon installers also check that the installed cable will indeed reach PP1. This is done by checking the position of a mark made on the cable jacket at the position that represents the minimum length outside the TIB/TID structure required to reach PP1. Then the ribbons are grouped into bundles which match the prescribed connection at PP1, where groups of up to 8 ribbons are mated with the 96 channel (8x12) multi-ribbon cables. Spare ribbons have also been foreseen, either as reserve stock to use to replace those broken during installation, or ribbons to be installed as ‘dark-fibre’ alongside the nominally used ribbons, for use only if needed later to re-route a damaged channel where the ribbon cannot be physically removed and replaced.

The integration of the front-end parts has taken more time than expected in the sub-detector community. This was mainly due to the fragile nature of the parts, the number and density of channels, and the number of tests made to prove that all channels were working before moving to the next integration step. There have been very few accidents and breakages. Only 70 optohybrids out of almost 17000 installed optohybrids and 50 out of 3000 ribbon-fanouts have been damaged during installation. Damage and breakages occurred mainly due to mishandling during the early phases of installation. The integration centres were visited one or more times by the optical link team to discuss installation procedures and minimize the risk of damage. So far, all damaged optohybrids have been replaced with spares. The same applies to broken ribbons/fanouts except for some in the TOB and TEC which could not be easily removed and replaced. In this case the ribbons were repaired by cutting off the damaged end and fusion splicing a new ribbon pigtail.

III. CABLING AND CONNECTIONS AT P5

A. PP1 development

There has been significant effort recently on the final definition of the CMS Tracker PP1 patch-panels in the 2x16 phi-sectors around the inner edge of the CMS magnet cryostat. For the optical links, PP1 houses the in-line patch-panel, where the connections are made between the ribbon fanouts coming from the Tracker and the multi-ribbon cables coming from the service cavern USC55. In each sector the in-line patch-panel consists of a box of volume 600x90x150 (length x width x height, all in mm) containing 4 partially removable cassettes.

A prototype cassette is shown in Fig. 4 in the ‘open’ position, with the full complement of 5 multi-ribbon cables and 40 ribbons attached. The 4 cassettes can therefore manage up to 20 multi-ribbon cables per sector, i.e. 160 ribbons, or 1920 fibre channels.

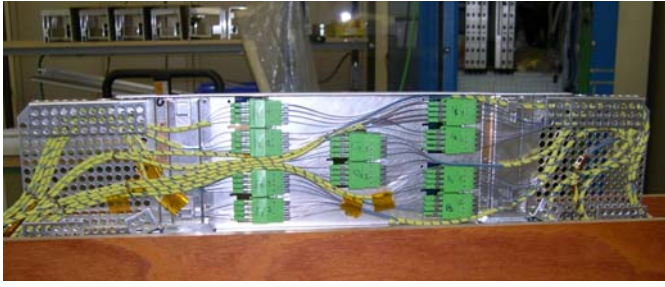

Figure 4: Prototype PP1 in-line patch-panel cassette (in 'open' position) complete with full complement of 40 ribbons (from the left) and 5 multi-ribbon cables (from the right) connected at 5 MFS connector blocks mounted in the centre of the cassettes.

The optical connector at PP1 is a variant of the MFS 12-way ribbon connector from Diamond, who also supply the in-line patch-panel, following developments in partnership with CMS. It is worth noting that the density of optical fibre is so high in the cassettes that the ends of the optical ribbons cannot be protected by cable sheath (over 80cm in the case of the ribbon cables, and 60cm for the multi-ribbon cables).

The overall PP1 housing beyond the in-line patch-panel cassette volume also includes some storage space for excess lengths of ribbon-cable at either end of the cassettes as well as strain relief elements for the multiribbon cables, about 10cm away from the cassettes.

Several in-line patch-panel prototypes have been produced by Diamond and tested at CERN. One was used successfully in the CMS MTCC. Delivery of all the final cassettes will be in October 2006.

B. Trunk-cabling (pre-cabling of YB0)

Preparations are under way for the optical cabling in CMS at Point 5, which will occur over several months after the CMS central barrel wheel YB0 has been lowered into UXC55 in 2007. The final trunk cabling involves laying and fixing of approximately 560 multi-ribbon cables on YB0 from the in-line patch panel (PP1) to the racks in the service cavern (USC55). A detailed cabling procedure, outlined below, has been developed and practiced in the MTCC.

The trunk cable connections between frontend (PP1) and backend patch-panels (at FED or FEC crates) follow a pre-defined map and route, which was proposed already in some detail several years ago, and was recently frozen. This map, in combination with work of CMS Integration group on routing the cables, allowed the lengths of cable to be defined so that the appropriate spectrum of cable lengths could be manufactured pre-terminated. As with the optohybrid pigtailed and ribbon/fanouts it was considered impractical to connectorize so many multi-ribbon cables on-site. This choice therefore required careful planning of the spectrum of lengths to be produced, which ranges between 45 and 65m in 5m bins. At least 5m of slack is planned for each cable path and there are in addition ~10% spare cables available.

The optical trunk cables for the Tracker will be probably installed last during the pre-cabling phase of the YB0. The precise cabling order has not yet been decided but it is

expected to be done one sector at a time with two teams, one cabling YB0+ and the other YB0-.

For a given PP1 sector, the appropriate selection of cables will be made from the inventory according to the number and lengths of cables prescribed in the cabling map for that sector. The cables will have protection elements attached, covering the naked optical ribbon sections at each end, allowing safe handling by the cabling crew. It is expected that each cable will be associated to a specific final path and have a CMS (INB) label attached just before installation. The cable 2-D barcode (QR code) will be scanned and then associated with the CMS/INB code in our cable map and inventory.

The actual installation of optical cables will probably be made one-cable at a time, starting from the balcony nearest the passage between USC55 and UXC55 (recall Fig. 2). The end with MFS termination will be threaded along the intended path to PP1 where it will be fixed in a strain relief at the appropriate position. The cable will then be fixed in the correct position in cable trays all the way back to the balcony. The other end of the cable, with MPO termination can then be pulled through the passage to USC55, where it will be routed towards the intended destination rack along pre-defined cable tray routes in USC55. All of the remaining cable length will be pulled through from UXC55 to USC55 with the slack being taken up, in most cases, in the 1.8m tall false floor beneath the rack, wound on a special figure-8 shaped support. This winding technique allows the ribbon stack inside the trunk cable sheath to relax, avoiding the stress and strain that would occur if the ribbons were wound on a simple circular spool. The position of some racks, e.g. those over a void in the false floor, precludes this slack storage solution beneath the rack and it is expected that the slack on these cables will be stored instead either nearby the rack in the false floor, or on the cavern wall in UXC55.

The time to lay a cable from PP1 to back-end patch-panel is expected to be 1 hour, so the total time required is approximately 600 hours divided by the number of teams working in parallel, e.g. cabling both sides of YB0. In addition to a 4-5 man CMS cabling crew that lays/pulls/fixes the cables (which is likely to be the same team that laid the electrical cables), a large team of trained people from the Tracker is required: 2 people to prepare, label and handover the cables to the cabling team and 2 people at each PP1 and then 2 people at the back-end patch-panels ready to receive the cable-ends, i.e. up to 8 Tracker personnel per shift.

At PP1, the tracker personnel remove the protection on the naked ribbon end of the cable and then mount the MFS connector block in the correct PP1 cassette and slot. This operation normally requires only a few minutes per cable, so it should be possible to carry out this task before the next cable arrives. It is intended that the cables are laid in an order that reflects the most efficient manner of stacking and attaching the cables at PP1. The order of trunk cabling should fill one cassette at a time, in an order, e.g. slot 1 through 5 in the cassette, which will allow the fastest and easiest installation of the naked ribbon cables and management of the naked ribbon slack length inside each cassette. This step has been practiced in the lab and the routing of slack ribbons in a cassette can be seen in Fig. 4 (where multi-ribbon cables enter on the right hand side as viewed).

C. Tracker cabling at Point 5

After the pre-cabling of YB0 is completed, the Tracker can be lowered and installed inside CMS at Point 5. Before transport to Point 5, the ribbon pigtailed and connectors from the Tracker will have been stored on the 'nose-cones', which are substantial mechanical frames at each end of the Tracker support tube that are used for Tracker insertion.

One immediate aim, after the Tracker is lowered and inserted into CMS, will be to clear the nose-cones quickly of both optical and electrical cables, in order that the beam-pipe can be installed without undue delay. The optical ribbons will be laid in cable channels in each sector from the Tracker periphery up to the PP1 patch-panels. Once the ribbons arrive at PP1, the optical connections will be made to the multi-ribbon cables. Note that after pre-cabling of YB0, when the in-line patch-panels are installed and filled with MFS blocks from the multi-ribbon cables, there will be no other space available to store temporarily Tracker ribbons during beam-pipe installation, so the final optical connections have to be made.

Before connection at PP1 every ribbon connector in the bundle will be cleaned with an appropriate fibre-cleaning tool, and checked using a special inspection microscope if time permits. There will be human-readable labels on the MFS adapters that the fanouts are attached to, and the barcode on at least one ribbon in a given bundle (up to 8 ribbons) will be scanned in order to lookup and validate the optical connection. The final list of connections made will be uploaded later to CMS Tracker and CMS databases.

There exists a potentially difficult issue of slack management at the in-line patch-panel. A large amount of slack can be absorbed easily in the cassettes, e.g. up to 50cm is stored already for the trunk cables as shown in Fig. 4, but this slack has to be common to the whole ribbon bundle. A problem arises with the ribbons coming from the Tracker, where there could be a variation of up to 10cm between individual ribbons in the same 8-ribbon bundle. This mismatch of slack length cannot be accommodated inside the in-line patch-panel cassettes. The solution has therefore been to leave some space available between the end of the Tracker cable channel and the in-line patch-panel cassettes, approximately 170mm long x 150mm deep x 90mm wide. The mismatch in ribbon slack can be stored here and the remaining pigtail lengths equalized before the ribbon bundles enter the cassettes. Arranging that the mismatch in slack lengths is confined to this space will be a very delicate operation, however it should become easier with accumulated experience.

These final stages of Tracker cabling and connections were all practiced on a small scale (33 ribbons in one cable channel) in the MTCC. It is foreseen to practice in the Tracker PP1/cable-channel mock-up in Q4 2006, using a maximally occupied channel having 140 optical ribbons.

A first estimate of manpower for Tracker ribbon cabling and connection has been made, based on our experience in the MTCC. It is expected that a trained 4 person team is needed per PP1 sector, 2 people to lay the fibre bundles into the cable channel and 2 to make the routing, connection and slack management at PP1. Connecting 40 ribbons to a single in-line

patch-panel cassette requires approximately 2 hours if the ribbon bundles have been well prepared. This suggests that 1 sector (out of 32 in total) can be cabled per 8-hour shift per team. Given the likely time-pressure, very careful preparation work at the Tracker Integration Facility (TIF) will be required to ensure that the ribbons for a given sector are already divided into appropriately labelled bundles, making their installation into the cable channels and subsequent connection at PP1 as easy and as fast as possible. It is expected that this preparatory work in the TIF will also require the effort of several people for a period of several weeks. The precise arrangement of the fibres on the nose-cones is currently being discussed and will be decided after practicing with the Tracker PP1/cable-channel mock-up at CERN.

IV. TESTS OF CABLING AND CONNECTIONS

Extensive QC (acceptance) tests of the final cabling and connections are foreseen. These include visual inspection of the cabling, connections, cable/connector barcode validation, plus measurement of the optical link performance in terms of light-loss in the cables and connectors.

Again, time-pressure is expected and these tests of the cables and connectors will have to be done in parallel with the installation. As the cables require a lot of time to install it is expected that the additional time required for acceptance tests might not be significant, and it should fall conveniently into the shadow of the installation work, as long as sufficient manpower is available.

If a break in a cable is suspected during installation, it can be checked with either a simple light-source/camera inspection tool (for a basic test of the trunk cables only) or using a specialized instrument such as an optical time domain reflectometer (OTDR). As well as detecting broken optical fibre channels or poorly mated optical connections, an OTDR also provides a very precise measurement of the cable lengths in the system, which is needed later for the synchronization of the Tracker[5].

It is planned that a high resolution OTDR will be used for final acceptance of the pre-cabling of YB0 and then again later for testing the full optical link system, in particular the connections made at PP1. These will remain accessible for some time before LHC start-up and suspect connections can be cleaned and re-mated if necessary. The measurement setup is illustrated in Fig. 6, which shows how a full link will be measured, 12 channels (1 ribbon) at a time, using the OTDR and a customized optical splitter. The splitter has staggered lengths on the different outputs which allow the reflected signals on the 12 fibre channels to be separated while being measured simultaneously.

If the cable is unbroken and correctly connected at PP1 a trace such as that shown in Fig. 6 is expected. Here there are strong peaks in the trace resulting from reflections at the ends of the fibres just in front of the laser diodes. The lengths of the different optical links can be calculated based on these signals and the known lengths of the launch cables and the different splitter arms. The precision is around 10cm, i.e. sub-nanosecond uncertainty when feeding these data later into the Tracker synchronization procedure[5].

However, if there are additional peaks in the OTDR trace, for example at the expected PP1 position, or at a point within the ribbon fanout length, and in particular if the peaks normally associated with the laser are missing, these will indicate problems either at the PP1 connection or in the front-end section of fibre. In case of difficulty or uncertainty in interpretation the OTDR traces, the 12-channels in question can be flagged and re-measured using a similar setup, but with an optical switch instead of the splitter, so that the ribbon is measured one fibre channel at a time.

In case of problems, there are a variety of solutions available. If there is a broken ribbon or multi-ribbon cable between PP1 and USC55, the optical links can be re-routed through a spare cable, as there will be one spare multi-ribbon cable available per sector, plus some of the other multi-ribbon cables also contain unused ribbons that could be exploited. Suspect connections at PP1 can be re-inspected, re-cleaned, re-mated and re-tested until either fixed or confirmed as being faulty. Breaks in ribbons in the cable channels between PP1 and the Tracker might also still be repairable depending upon time/access available for a spliced repair. In contrast problems suspected to be close to or inside the Tracker volume will be irreparable and these will only be flagged for reference, to be re-checked once the Tracker sector in question is powered.

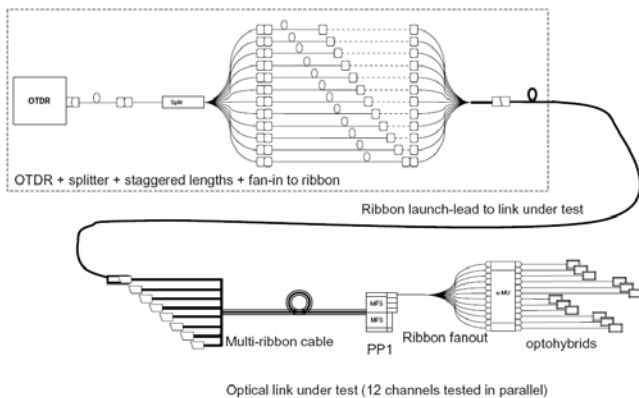

Figure 5: OTDR setup with splitter and optical link under test. The splitter allows measurement of 12 channels (sharing the same ribbon) at once and the staggered lengths allow differentiation between the separate fibre channels.

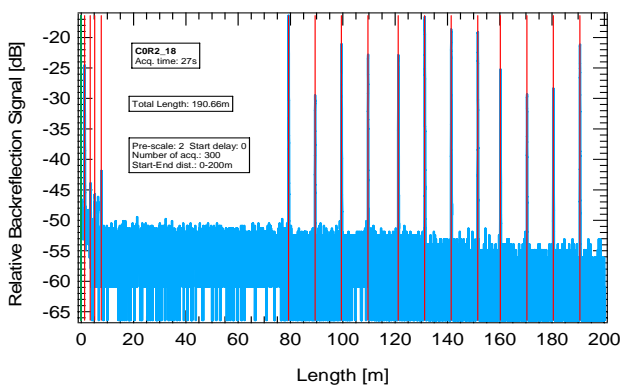

Figure 6: Typical OTDR trace for 12-channels of fully connected optical link measured with the setup shown in Fig 5. The vertical lines on the right hand side indicate peaks from reflections at the 12 lasers. Lines/peaks at the left hand side are from launch connections.

V. CONCLUSION

There has been excellent progress so far in integrating the optical links into the CMS Tracker. The various subdetectors are close to completion, very few problems have occurred in the optical cabling and connections and the links function very well. A significant effort is now underway to install a large quantity of optical links (~12000 fibre channels) in the TIF at CERN for the remaining tests on the Tracker before it is ready for transport to Point 5.

For the final optical link integration steps of pre-cabling of YB0 and then cabling and connection of the Tracker after insertion into CMS, all the preparations are also well underway. A cabling procedure has been written and practiced in the CMS MTCC for YB0 pre-cabling of the multi-ribbon cables, and for cabling and connection of the Tracker optical ribbons. The resources required have been estimated for cabling/connection activities at Point 5. Finally, an extensive array of test tools and procedures is now in place, including a sophisticated OTDR cable/connection tester.

ACKNOWLEDGEMENTS

In addition to our very helpful colleagues in the CMS Tracker and CMS Integration groups, Christophe Sigaud, Robert Camus, Gerard Sanchez, Jeanine Muffat-Joly and Pedro Podesta are thanked for their valuable assistance.

The HELEN Latin-American exchange programme is acknowledged for providing support to Pedro Podesta and Isabel Pedraza.

VI. REFERENCES

- [1] CMS Tracker Technical Design Report. CERN LHCC 98-6. (1998)
- [2] CMS Tracker optical links web-pages: www.cern.ch/cms-tk-opto
- [3] J. Troska et al., Proceedings of 12th LECC Workshop, Valencia, September 2006.
- [4] S. Dris et al., Proceedings of 10th LECC Workshop, Boston, September 2004, CERN-2004-10, pp 164-168. (2004)
- [5] K. Gill, L. Mirabito and B. Trocme, Proceedings of 9th LECC Workshop, Amsterdam, September 2003. CERN-2003-6, pp 289-293. (2003)