



Elettra Sincrotrone Trieste

CLIC Workshop 2017

HIGH GRADIENT, S-BAND STRUCTURES *An Upgrade Plan for the FERMI FEL*

C. Serpico, S. Di Mitri, N. Shafqat, S. Nicastro

Motivation

Upgrade Goals

New Accelerating Modules

- RF Parameters
- RF Couplers
- Energy Budget

Prototype

- Test Facility Upgrade

Wakefields Analysis

Beam Dynamics

Conclusions

FERMI is usually operated in 2 different configurations depending on the repetition rate:

- Low repetition rate: 10 Hz → Energy in DBD = 1.55 GeV
- High repetition rate: 50 Hz → Energy in DBD = 1.37 GeV

Linac Layout

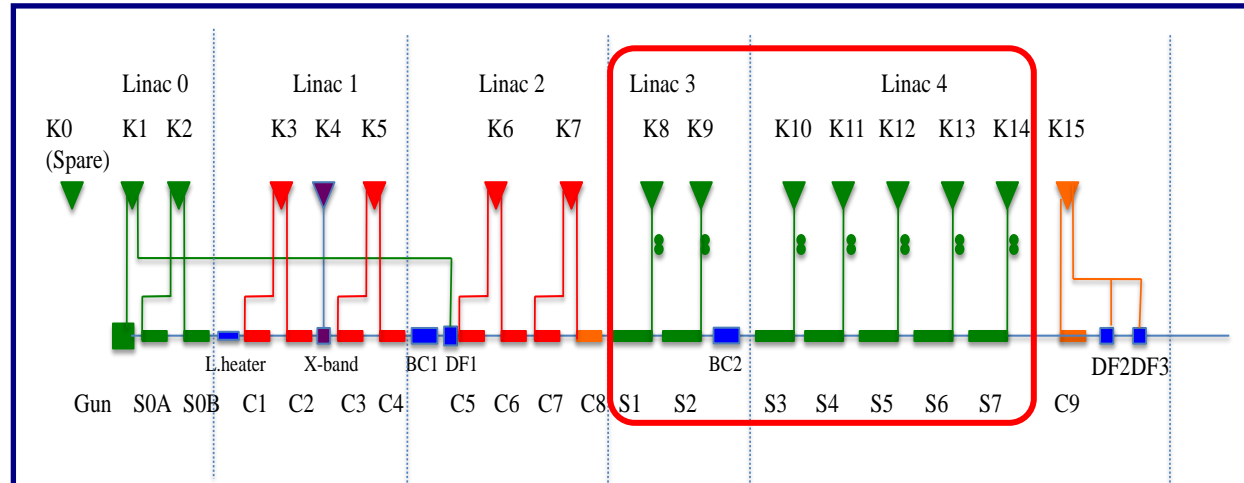

- Limitations come essentially from the BTW structures
- Small beam apertures (i.e. 5 mm iris radius) bring significant longitudinal and transverse wakefields effects.



Clear signs of breakdowns are evident of inner surfaces.

SHORT TERM GOAL:

- A routinely operation at **1.55 GeV** (after compression) and **50 Hz**.
- Longitudinal and transverse wakefields effects shall be mitigated (with respect to the actual BTW structures).

MEDIUM TERM GOAL:

- Peak energy of **1.8 GeV**.

New Accelerating Modules

RF Parameters

- The new accelerating module will be comprised of two 3.2-m long accelerating structures .
- Each structure will be of the **constant-gradient type**.

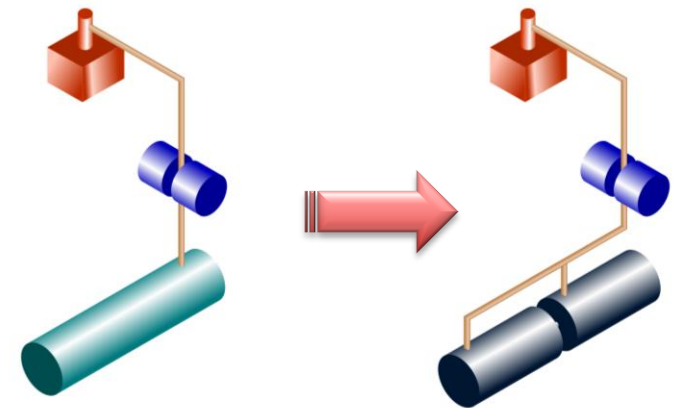

Structure RF parameters

L	3175	mm
Ncells	90	
a	11.4 → 9	mm
Q_0	15800	
R_{sh}	71 → 80	MΩ/m
Attenuation	0.38	Neper
Filling Time	650	ns

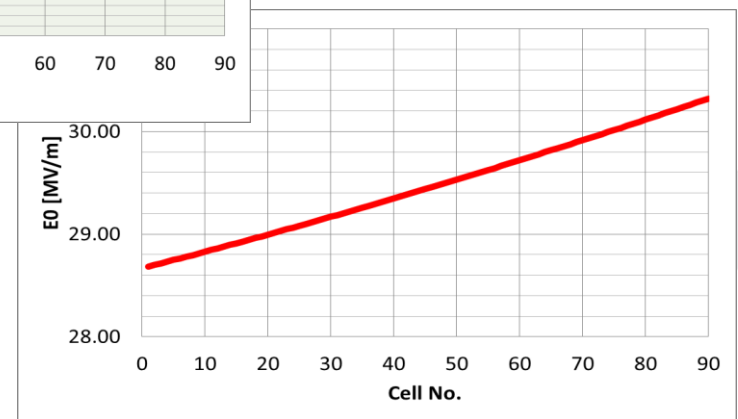
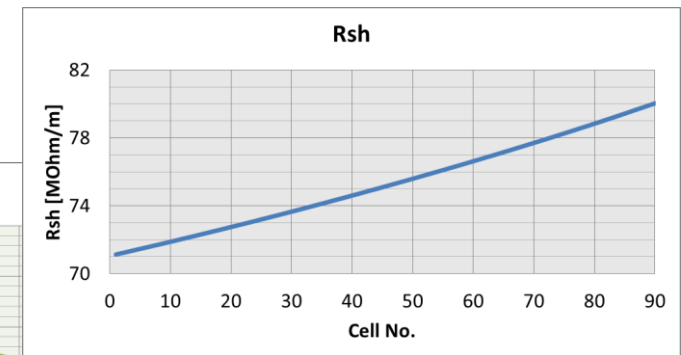
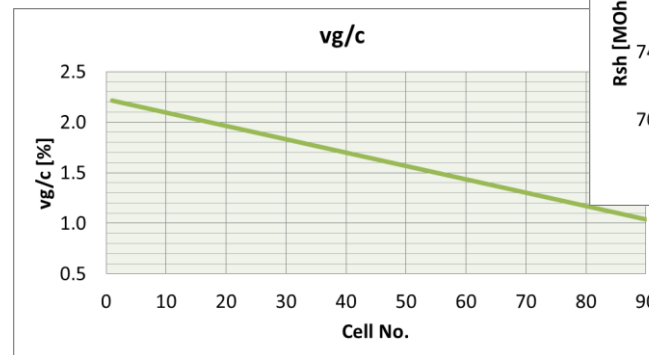

New Accelerating Modules

RF Couplers

C. Serpico, A. Grudiev (CERN)

Magnetic Coupled

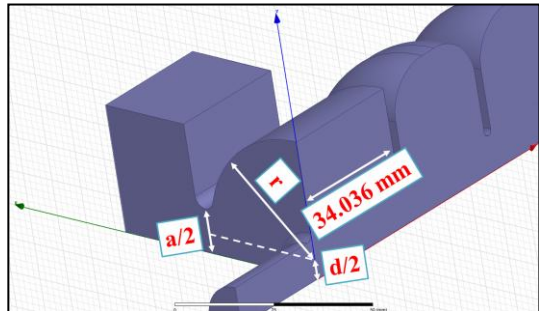

vs

Electric Coupled

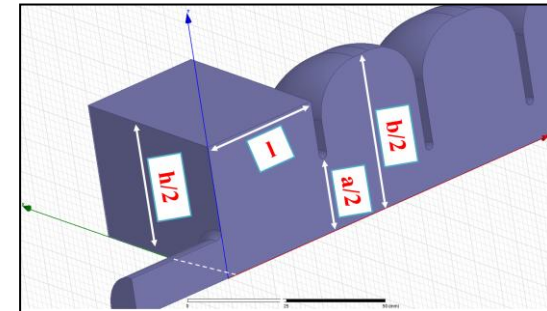

Working Point

$$V_0 = 30 \text{ MV/m}$$

$$\Delta T = 700 \text{ ns}$$

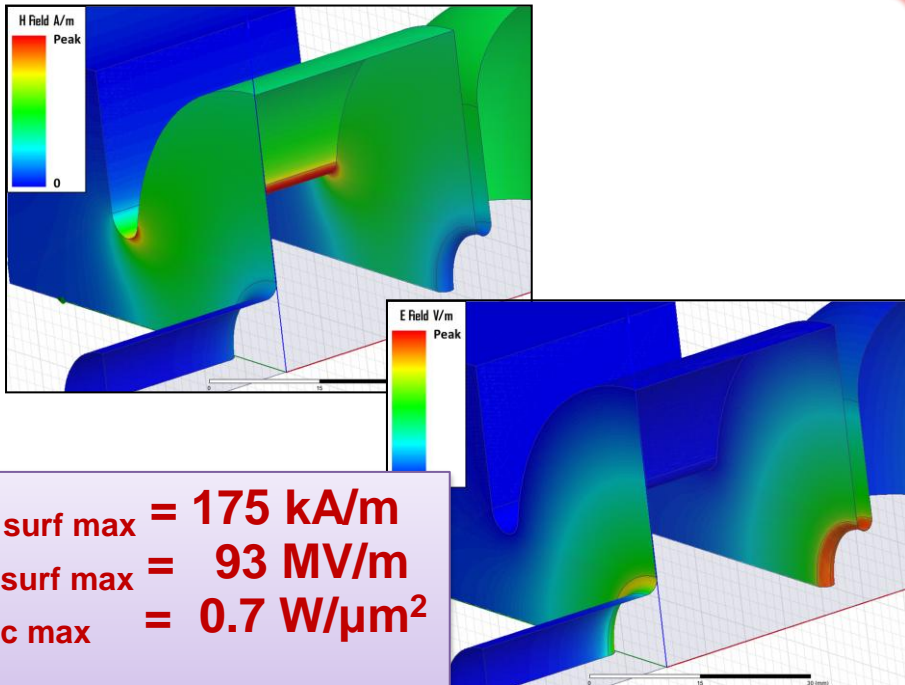

$$H_{\text{surf max}} = 175 \text{ kA/m}$$

$$E_{\text{surf max}} = 93 \text{ MV/m}$$

$$S_{\text{c max}} = 0.7 \text{ W}/\mu\text{m}^2$$

$$\text{BDR} = 10^{-12} \text{ bpp/m}$$

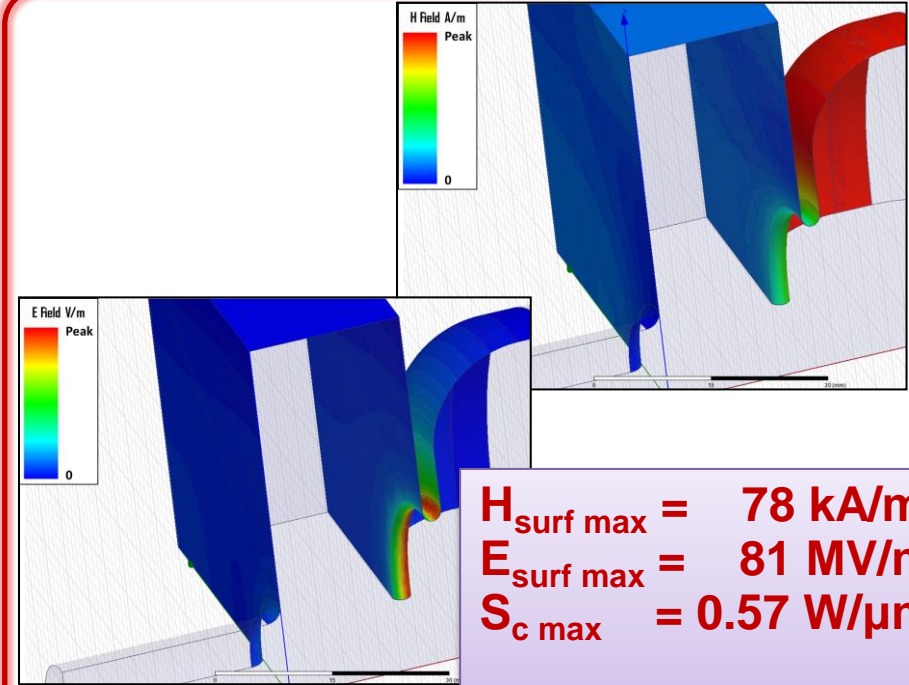

$$H_{\text{surf max}} = 78 \text{ kA/m}$$

$$E_{\text{surf max}} = 81 \text{ MV/m}$$

$$S_{\text{c max}} = 0.57 \text{ W}/\mu\text{m}^2$$

$$\text{BDR} = 10^{-12} \text{ bpp/m}$$

New Accelerating Modules

RF Couplers

C. Serpico, A. Grudiev (CERN)

Magnetic Coupled

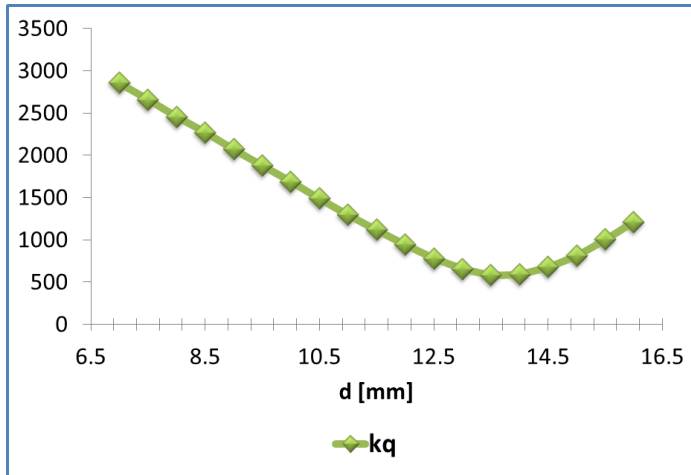

vs

Electric Coupled

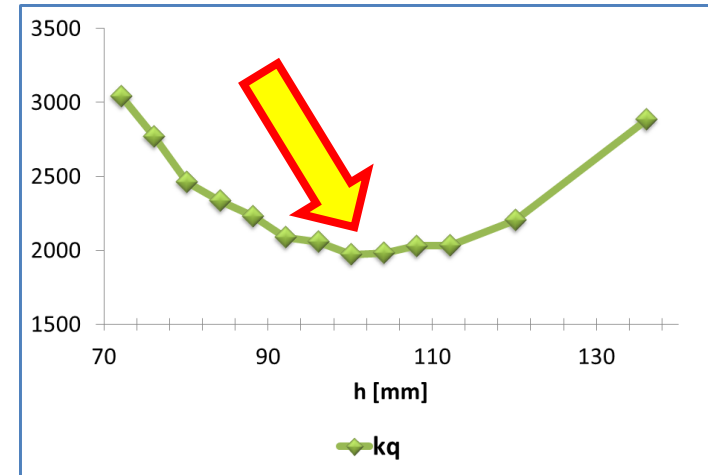

Integration is limited to the input coupler region

MINIMIZATION OF THE RESIDUAL QUADRUPOLE COMPONENT

$$F_\varphi(z) = [F_x(r = 5 \text{ mm}, \varphi = 45^\circ, z) - F_y(r = 5 \text{ mm}, \varphi = 45^\circ, z)]$$

$$k_q = \frac{1}{qr} \left| \int_0^L F_\varphi(z) e^{\pm j \frac{\omega}{c} z} dz \right|$$

- **EC coupler – Pros:** E-field and H-field are lower for the EC.
- **EC coupler – Cons:** residual quadrupole component is bigger for the EC coupler.

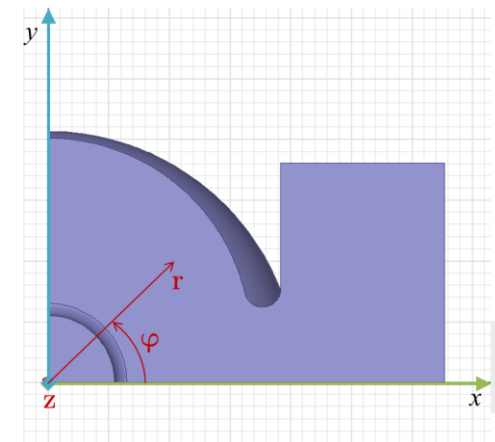

New Accelerating Modules

RF Couplers

C. Serpico, A. Grudiev (CERN)

Adjusting the relative phase of the fields at the input and output couplers it is possible to further minimize the overall residual quadrupole component

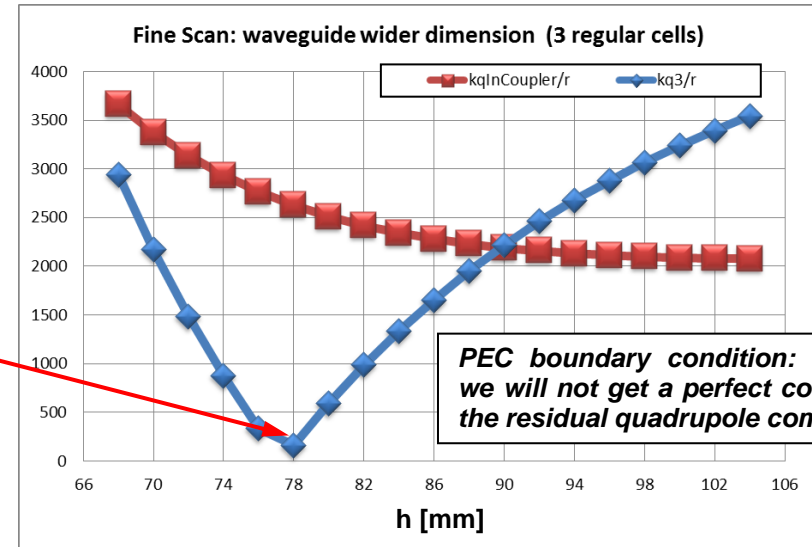
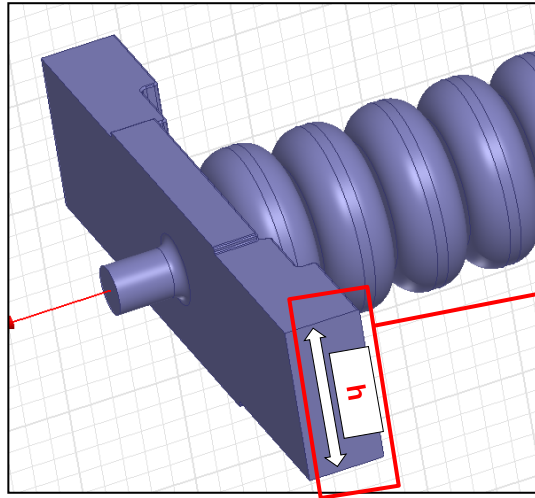

WG WIDER DIMENSION: 74MM

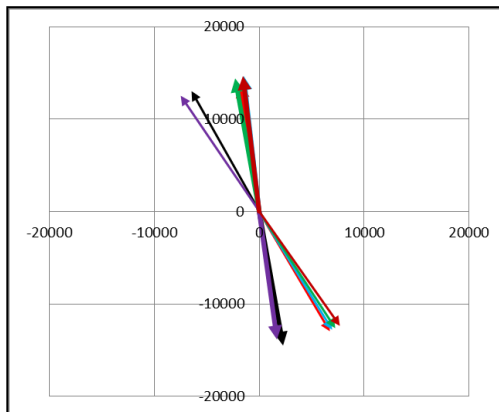

WG WIDER DIMENSION: 78MM

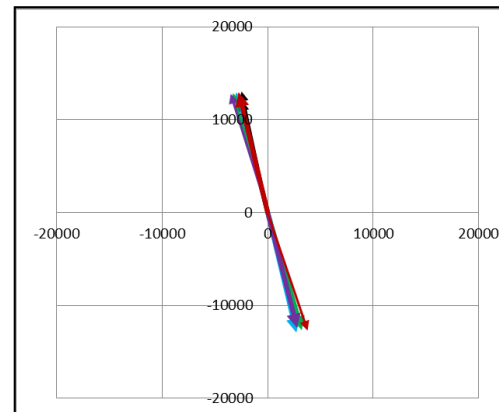

WG WIDER DIMENSION: 82MM

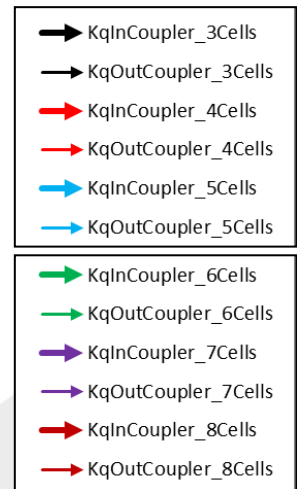
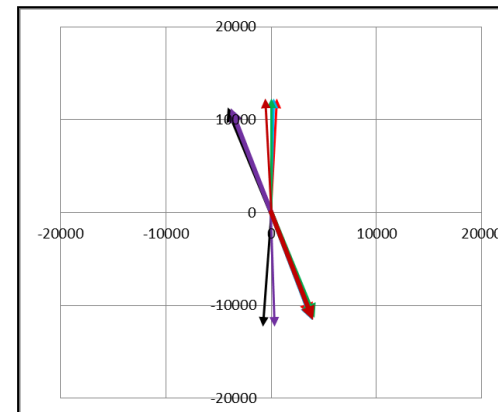

New Accelerating Modules

Energy Budget

MEDIUM TERM GOAL

- **1.80 GeV @ 50 Hz.**



Operating Gradient (Linac3 & Linac4)	30	MV/m
---	-----------	-------------



Klystron Power	42	MW
Pulse Width	4.2	us

Theoretically, an operating gradient of **30 MV/m** is achievable with the available power from actual klystrons

***An High Power Testing Program has been set up to demonstrate the feasibility and the reliability of operating klystrons, pulse compressors and structures at full power.
A first prototype will be machined and full power tested on the Test Facility***

A Specific Agreement for 3 different prototypes between the **PSI** and **Elettra** will be signed

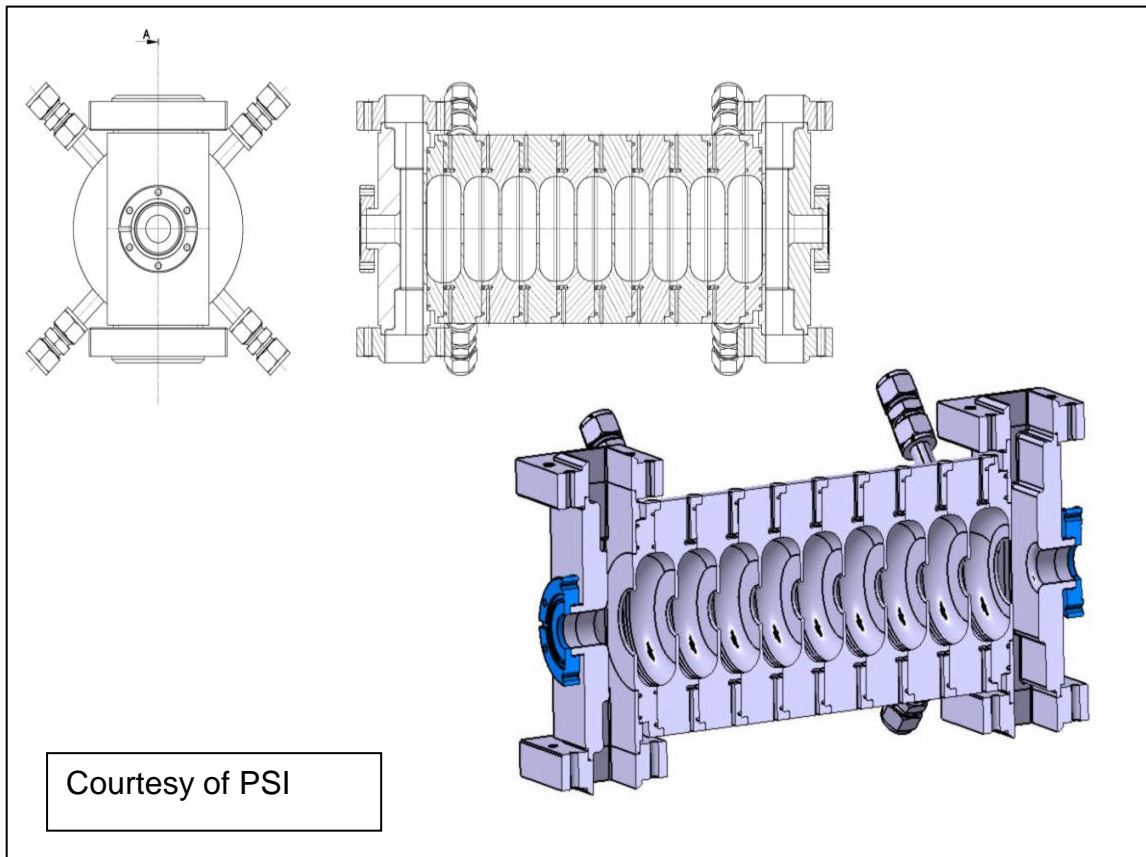

- Prototype 1 will be made of:
 - ◆ 2 RF Couplers
 - ◆ 2 Matching Cells
 - ◆ 6 Regular Cells
 - ◆ 1 Symmetric Cell
- PSI is finalizing the mechanical drawings
- **Prototype 1 will be ready beginning of 2018**

Prototypes

Test Facility Upgrades Layout

- The current Test Facility will be upgraded and equipped with a BOC pulse compressor (on loan from CERN).
- Installation will start in the Summer Shutdown

It will be possible to perform RF conditioning up to approximately 50 MV/m.

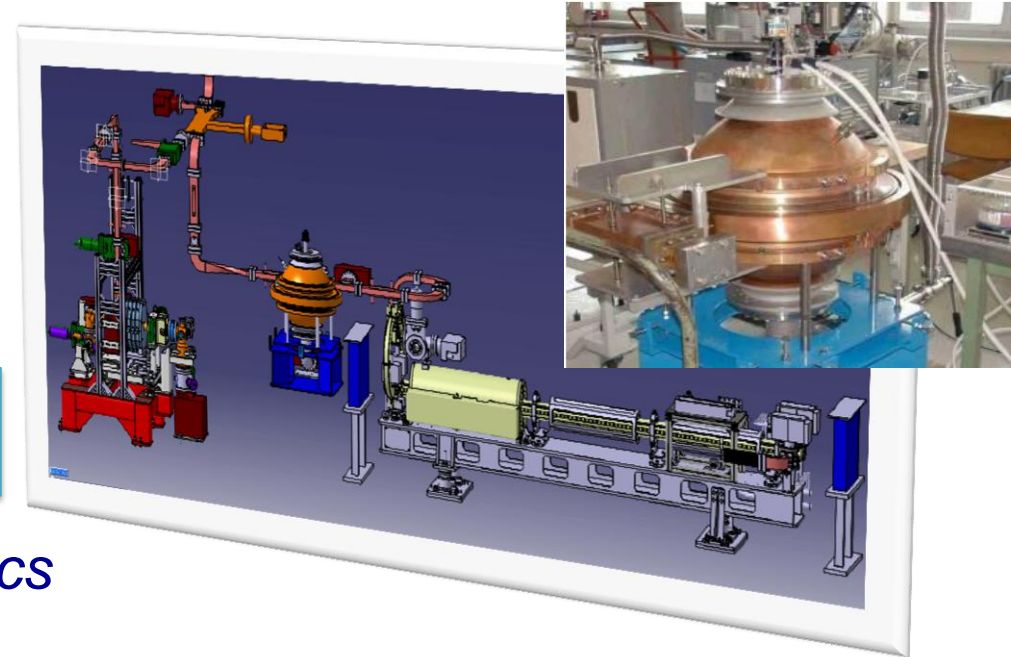

Diagnostics

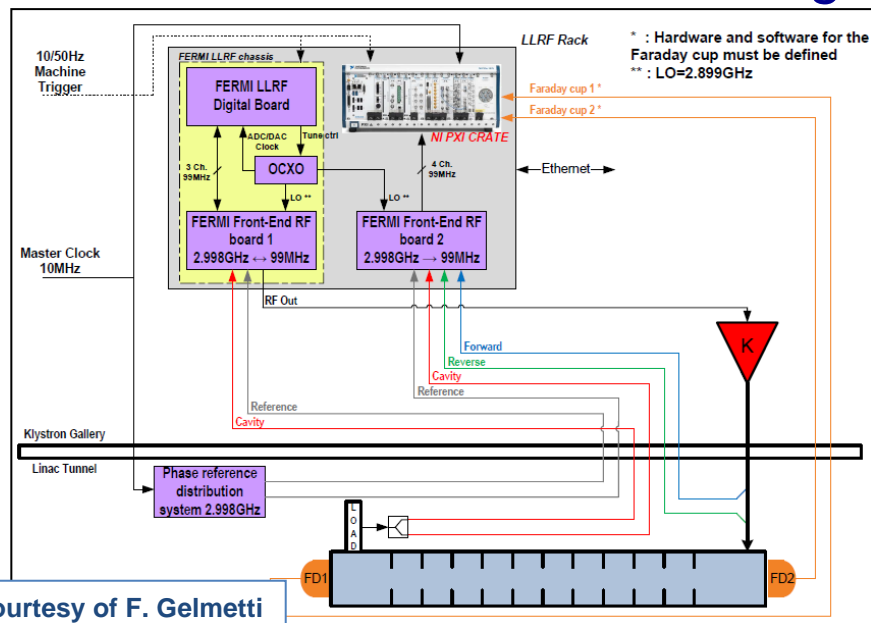

Courtesy of F. Gelmetti

Breakdown detection and localization

- Transmitted and reflected waveforms will be downconverted and then sampled using NI hardware.
- Labview routines will be developed to measure the breakdown rate and operate the RF conditioning.

Diagnostics will be developed in collaboration with CERN (ref. W. Wuensch)

Salient Features:

- 3D solver
- Extension of Time Domain Solver
- Robust due to different integration techniques
- Only available code for non-relativistic beams

CST

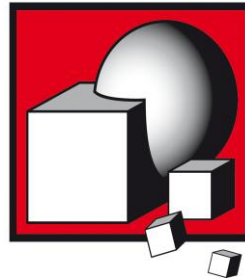

More computational resources and time are needed

Salient Features:

- 2D solver
- Wide acceptability in accelerator community
- High speed of execution with minimum use of computational resources



For relativistic beams only

Simulation Setup

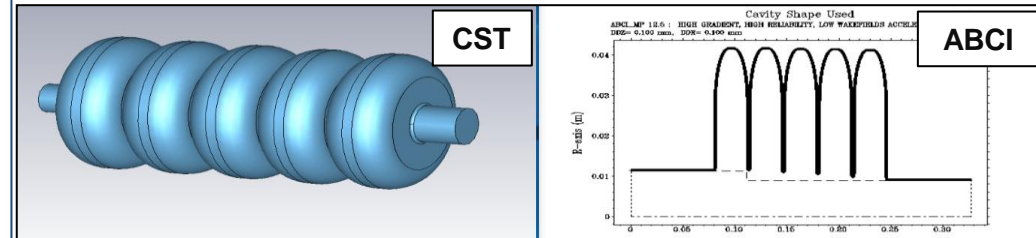

Benchmarking

Simulations were performed for complete 90 cell structure with both CST & ABCI

- Results from ABCI & CST were compared.

Length of Beam Pipe

- $D \geq \frac{a^2}{2\sigma_z}$ is beam catch up distance and beam pipe should be at least twice of D 80 mm BP was used

Choice of Bunch Length σ_z

- Ideally should be as small as possible as it defines the scale of HOMs
- Smaller sigma means denser mesh as mesh is fraction of bunch length making it impossible to simulate for μm bunches
- σ_z of 3mm which translates to around 35 GHz was chosen for wakefield simulation for complete structure

Wakefield Analysis

Longitudinal wake potentials on left and Transverse wake potentials on right for complete 90 cell structure with 3mm bunch length σ_z with CST and ABCI with 80 mm beam pipe

Resources and Time of Execution

ABCI 36 Hours

CST 194 Hours with 15GB RAM

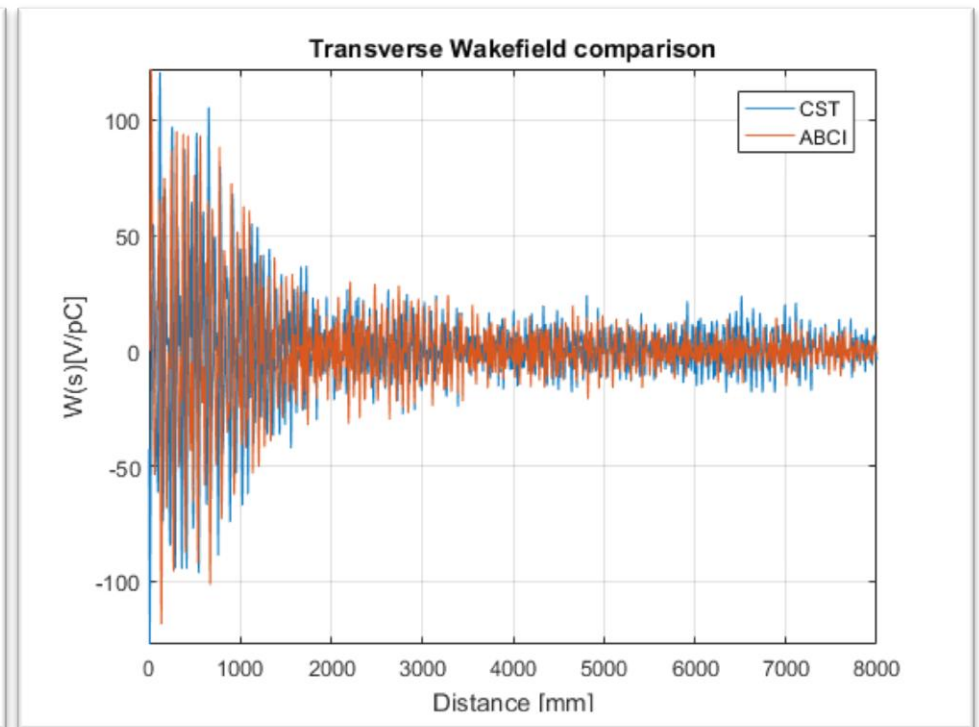
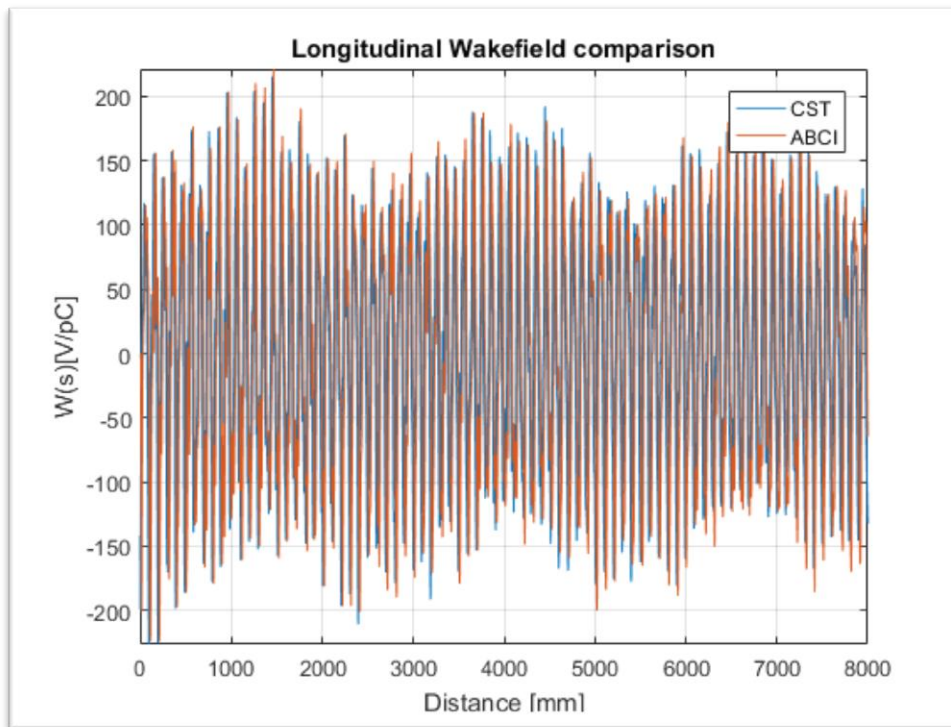

**Longitudinal Wake Potentials
Loss Factor [V/pC]**

ABCI	CST
1380	1290

**Transverse Wake Potentials
Kick Factor [V/pC/mm]**

ABCI	CST
5.68	5.38

Wakefield Analysis

*As expected fundamental mode at 2.998 GHz is coupled more strongly as compared to other HOMs
Fundamental mode was filtered mathematically using MATLAB and longitudinal wake potential due to
HOMs only was determined and plotted*

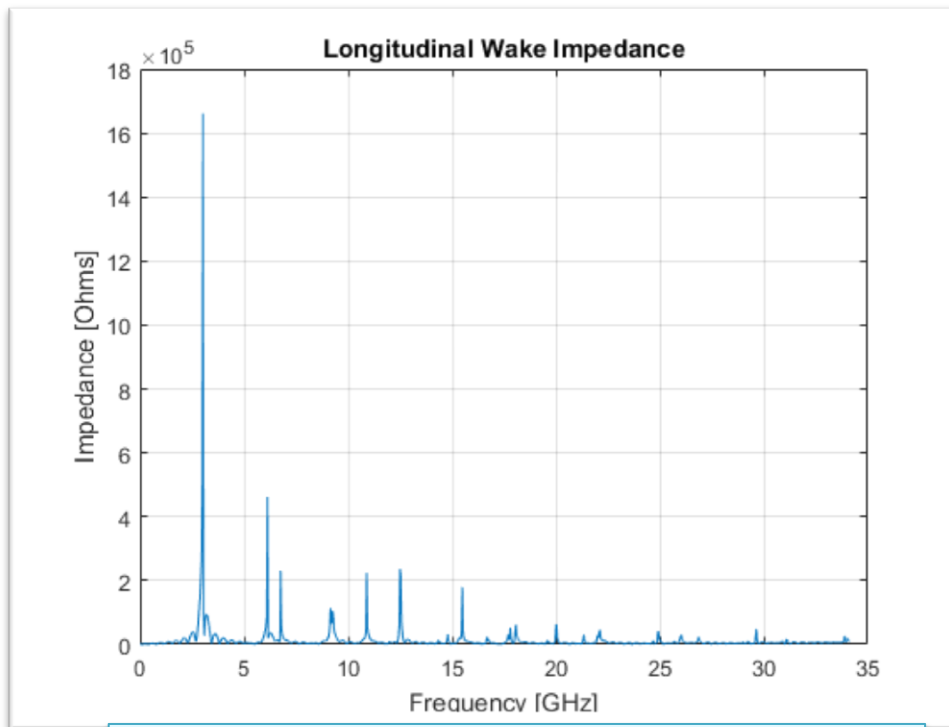

Longitudinal coupling impedance

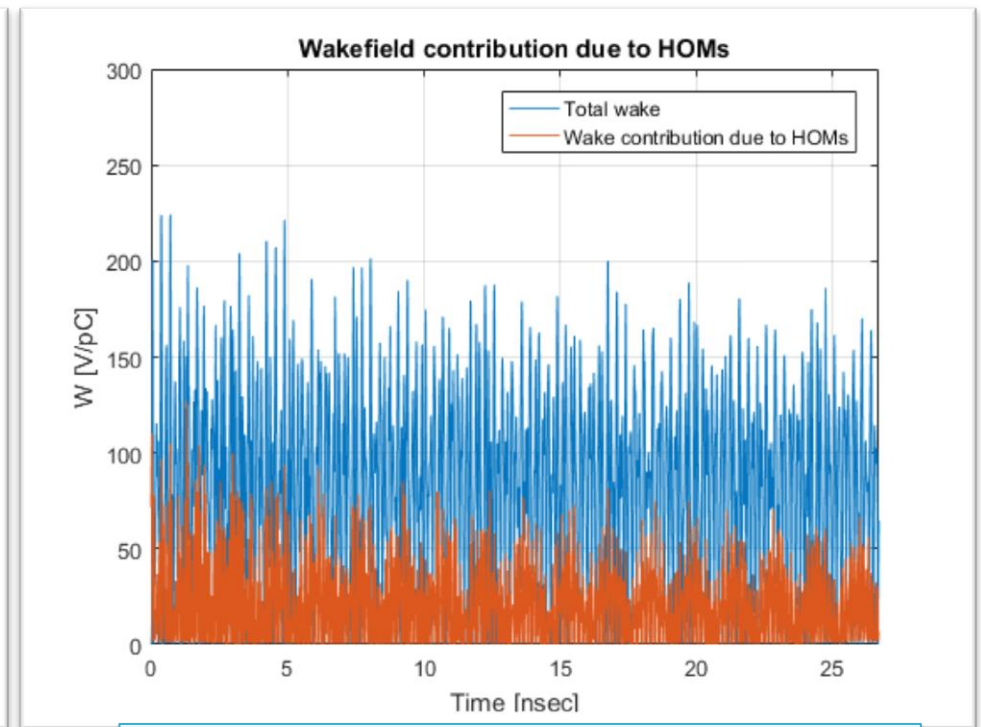

Contribution due to HOMs only

Two different techniques were tried

- **Taking Inverse Fourier Transform of wake impedance** from CST as it is already normalized by charge distribution.
 - Reaches to computational limit due to very short σ_z requirement as wake function is ideally for point charge & there is no way to extrapolate
- **By fitting equation to the envelop of wake potential for different σ_z** starting from mm to μm range which is possible computationally
 - Reaches to computational limit due to very short σ_z but we can very easily extrapolate in that range which is not possible

Simulation Setup for Complete 90 cell Structure

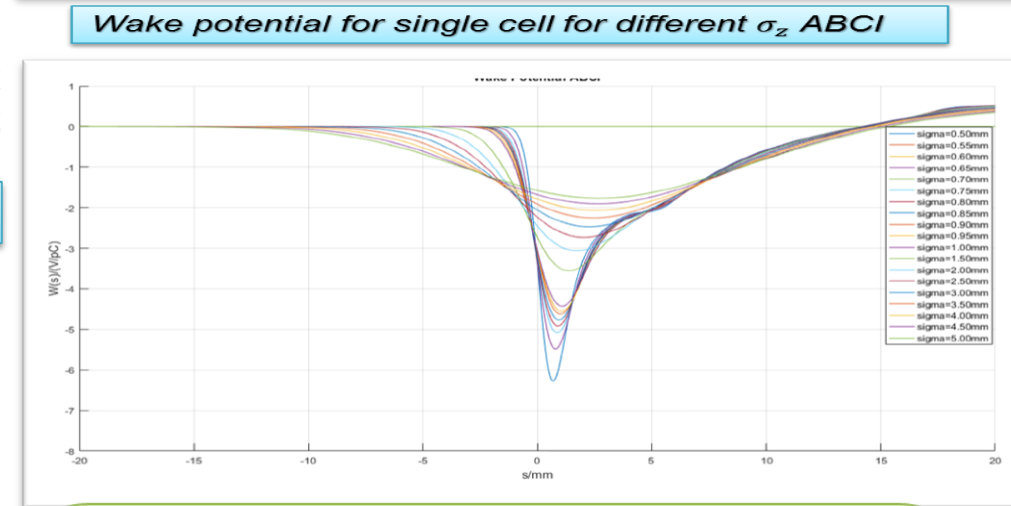
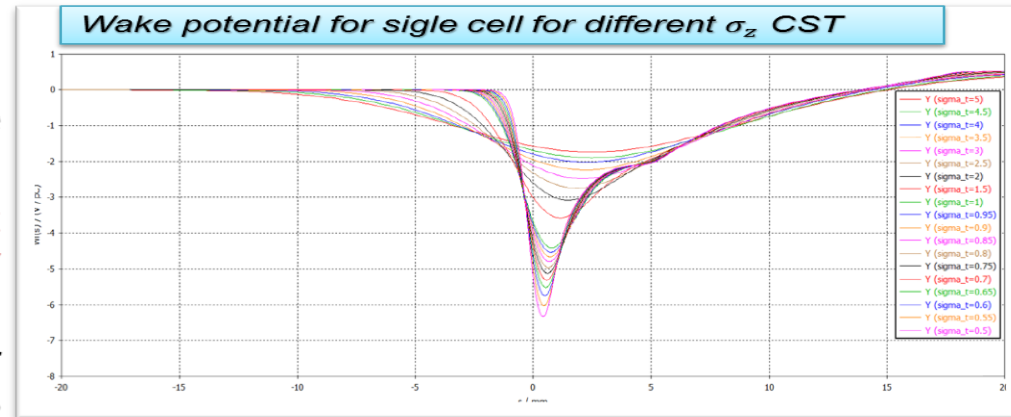
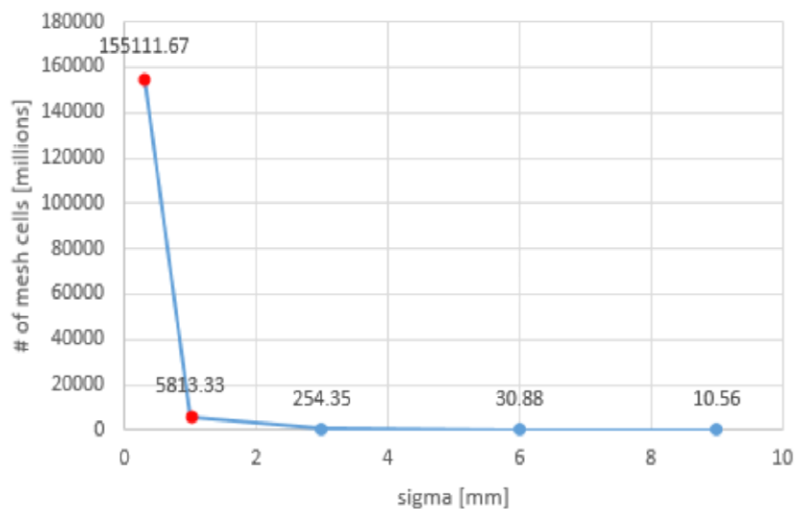

- It is computationally not possible to simulate complete 90 cell structure with 90 cells for $\sigma_z < 3\text{mm}$ due to non realizable mesh requirements
- So only ABCI was used for analysis of complete structure for $\sigma_z < 3\text{mm}$ to μm range but ABCI setup was bench marked with single cell with CST



Wakefield Analysis

$$G_{\perp} = 13778.149 \left(1 - (1 + \sqrt{2.2813s}) \right) e^{-\sqrt{1.444869s}} - 8834.2598 (1 - (1 + \sqrt{2.2813s})) e^{-\sqrt{0.95057s}}$$

$$G_{\parallel} = 260 e^{-\sqrt{\frac{s}{10^{-3}}}} + 100 e^{-\sqrt{\frac{s}{1.85 \cdot 10^{-3}}}}$$

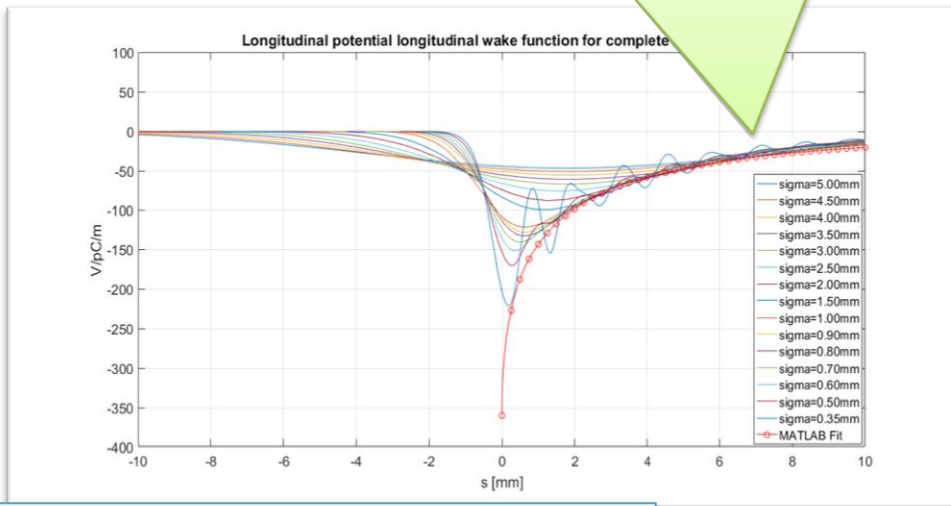

Longitudinal wake potentials for different lengths of Gaussian bunches and fitted wake function

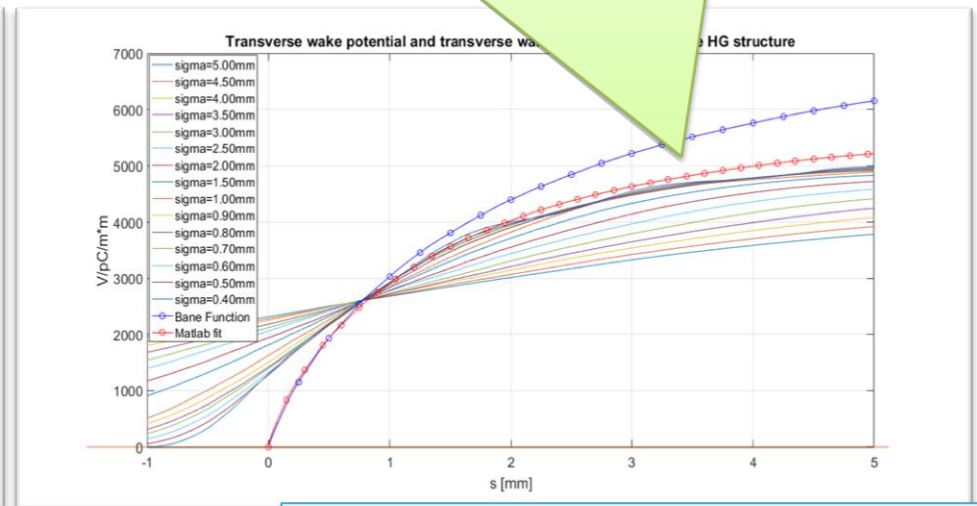

Transverse wake potentials for different lengths of Gaussian bunches and fitted wake function

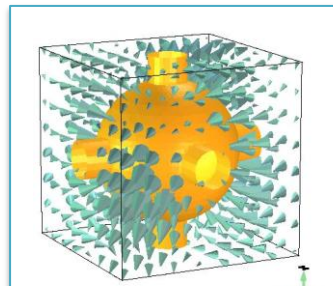

Further analysis will be done with Gdfidl

Beam Dynamics

Longitudinal Dynamics

ACTUAL LAYOUT

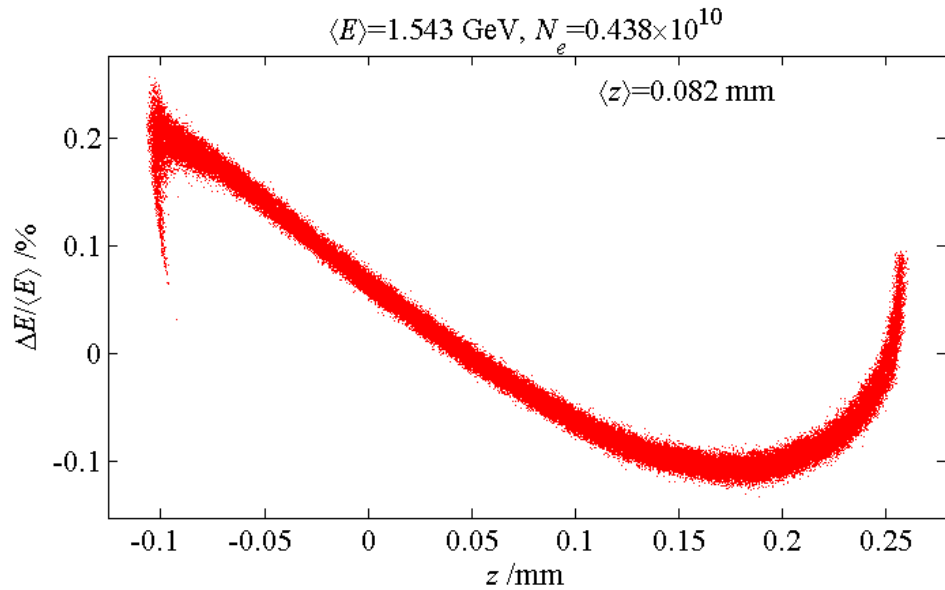

$h_1 = -1.395 / \text{mm}$
 $h_2 = 1.08 / \text{mm}^2$
 $h_3 = 35.2 / \text{mm}^3$

L4 phase shift from crest: 15°

SHORT TERM GOAL

- **~1.55 GeV @ 50 Hz**
- **Mitigated wakefield effects.**

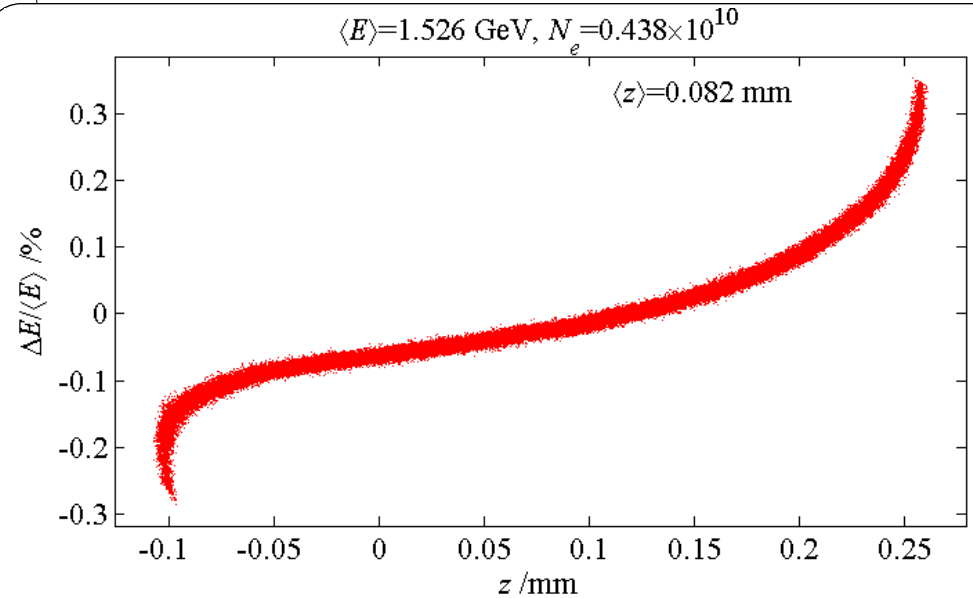

$h_1 = 0.485 / \text{mm}$
 $h_2 = 1.00 / \text{mm}^2$
 $h_3 = -25.4 / \text{mm}^3$
 $\sigma_\delta = 0.098 \%$

1.6% energy loss w.r.t. the maximum achievable

ACTUAL LAYOUT

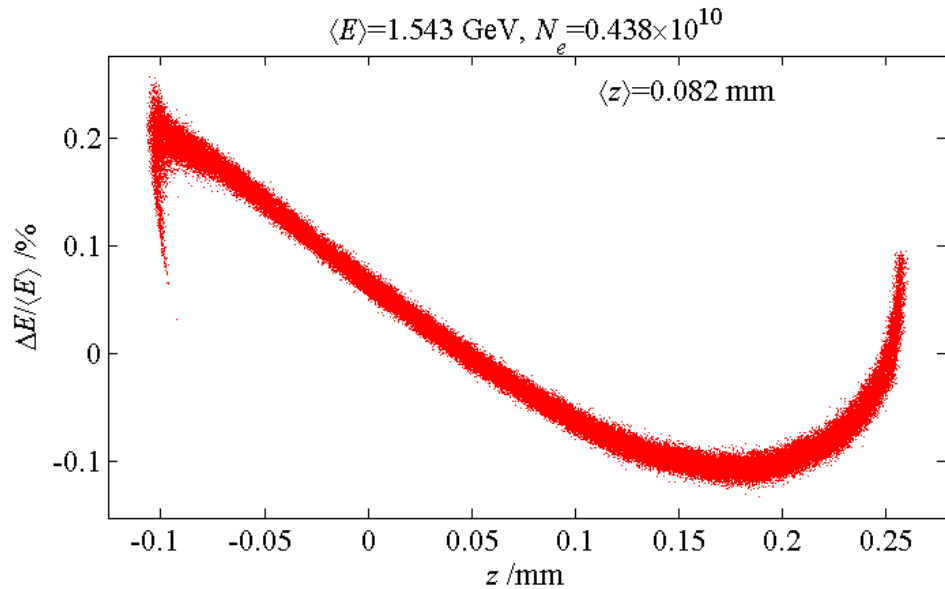

$h_1 = -1.395 / \text{mm}$
 $h_2 = 1.08 / \text{mm}^2$
 $h_3 = 35.2 / \text{mm}^3$

L4 phase shift from crest: 10°

MEDIUM TERM GOAL

- **~1.8 GeV @ 50 Hz**
- **Mitigated wakefield effects.**

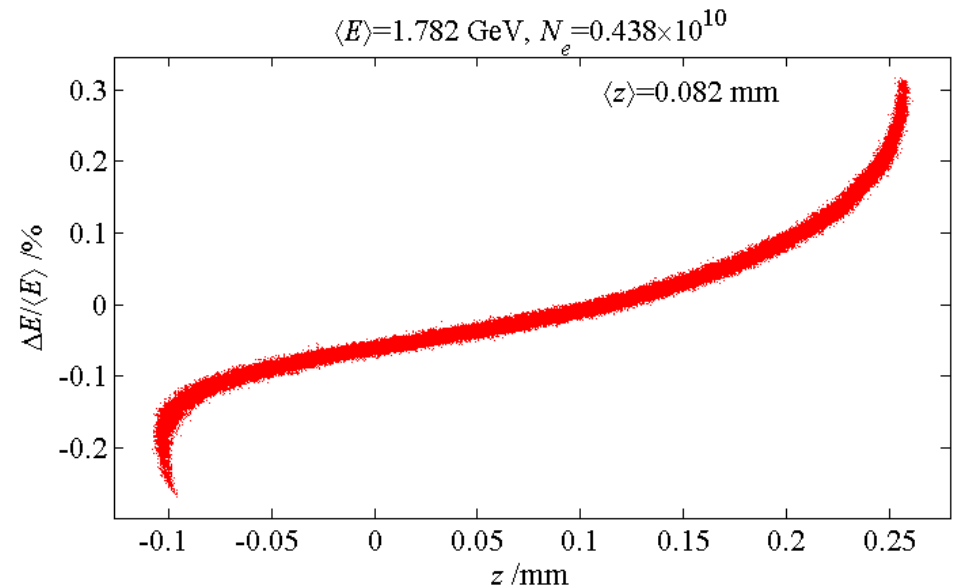

$h_1 = 0.564 / \text{mm}$
 $h_2 = 0.54 / \text{mm}^2$
 $h_3 = -30.3 / \text{mm}^3$
 $\sigma_\delta = 0.095 \%$

**~1% energy loss w.r.t.
the maximum achievable**

LINAC ENERGY AND RELIABILITY

- **1.80 GeV** energy can be achieved.
- Much lower breakdown rate even at full gradient (i.e. **30 MV/m**) and repetition rate (i.e. **50 Hz**).
- More robust FEL operation.

BEAM DYNAMICS

- Weaker wakefields contribution have been carefully evaluated.
- Energy chirps equal to or lower than the actual one can be achieved with a very modest energy loss (i.e. **~1% energy loss w.r.t. the maximum achievable**).

PROTOTYPE TESTING

- A Specific Agreement for 3 different prototypes between the PSI and Elettra will be signed.
- **Prototype 1** will be ready for high power testing at **beginning of 2018**.
- The Test Facility will be upgraded: RF conditioning will be possible **up to approximately 50 MV/m**.



Elettra
Sincrotrone
Trieste

Thank you!



Elettra
Sincrotrone
Trieste

