



Tracking validation and performance of the CLIC detector model



CLIC Workshop 2017
6-10 March

Emilia Leogrande (CERN)
emilia.leogrande@cern.ch

The detector model: CLIC_o3_v08

- ★ Experimental conditions
 - ★ $B = 4\text{T}$
 - ★ crossing angle: 20 mrad @ 3 TeV

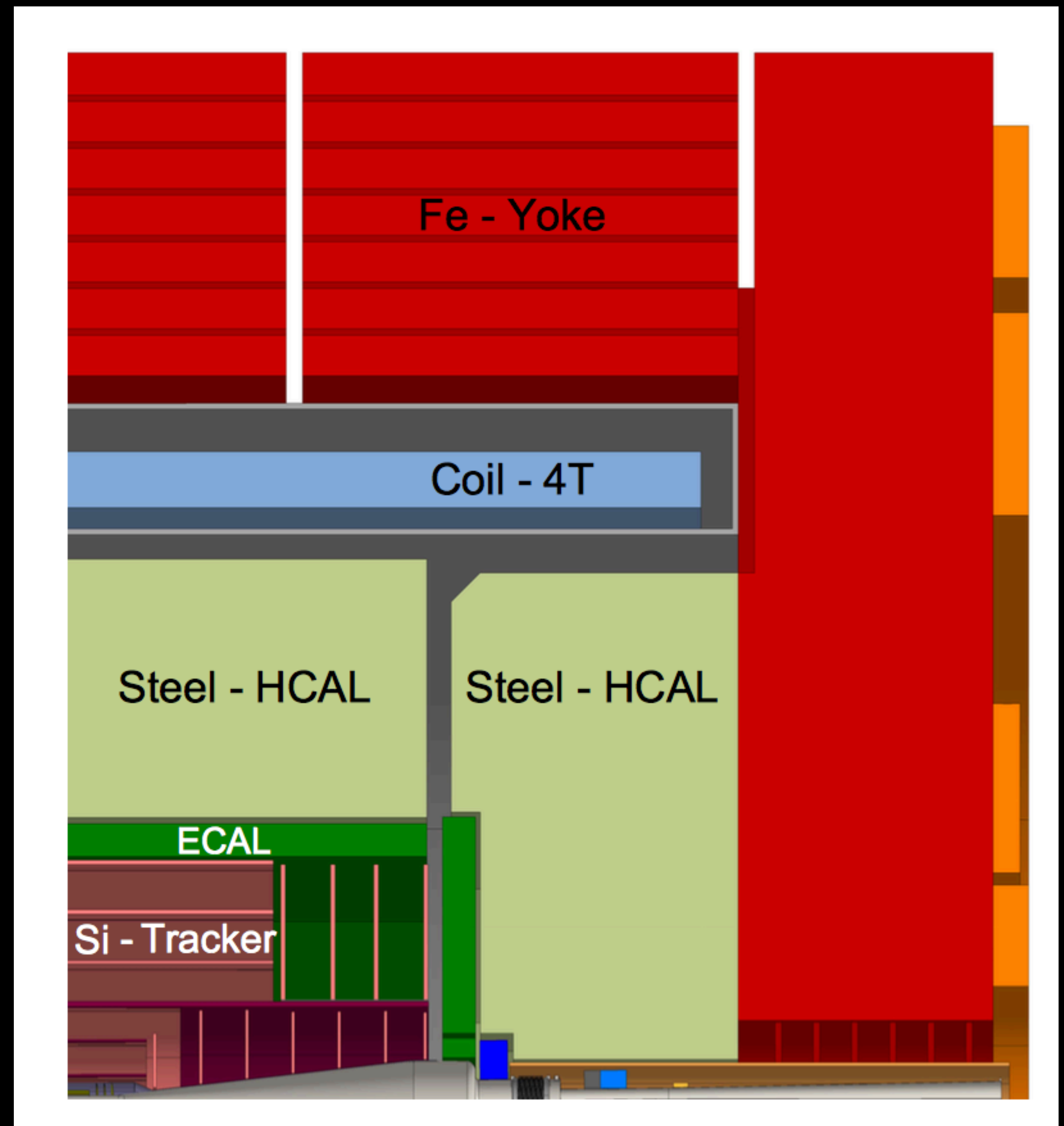
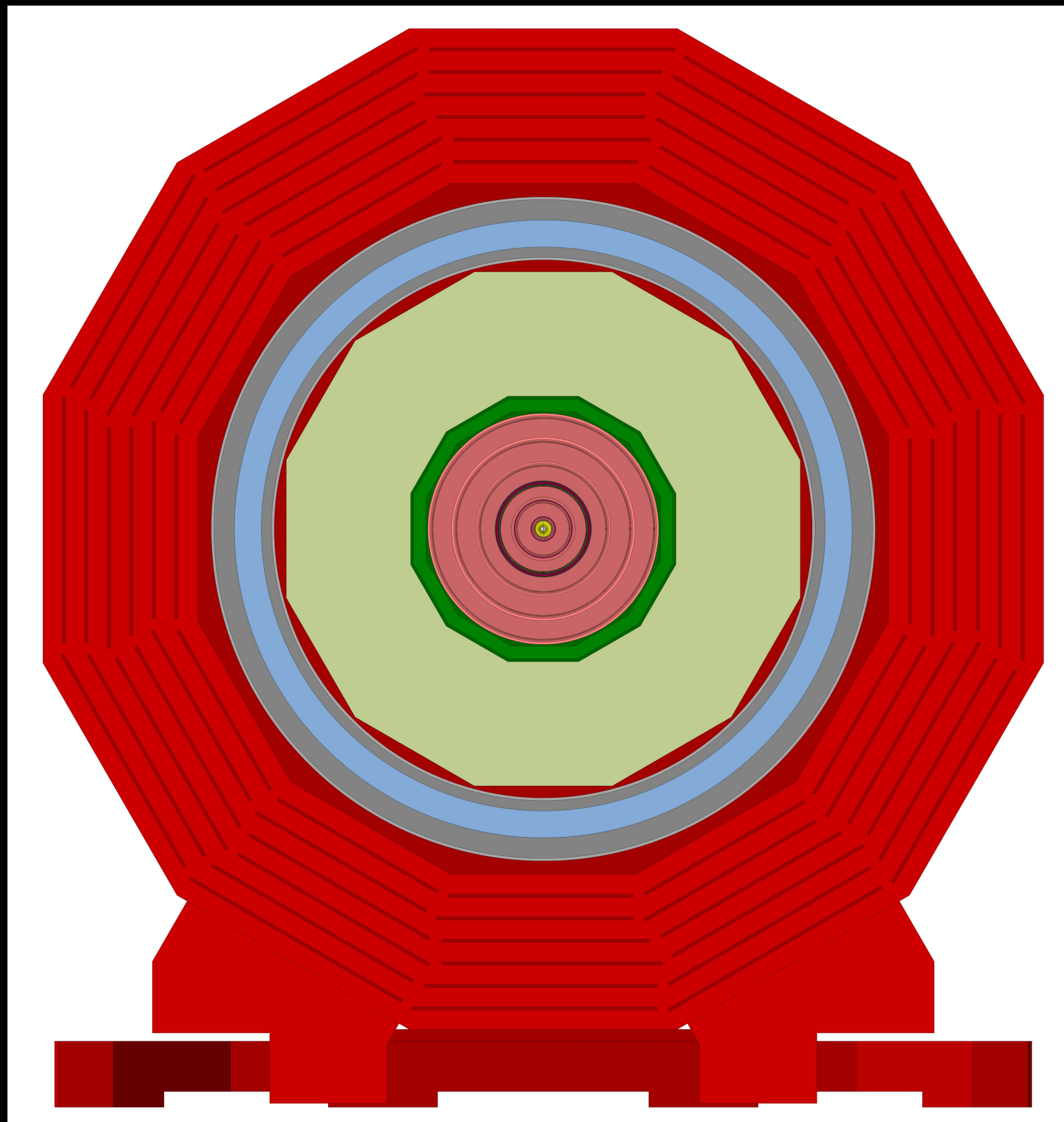

The detector model: CLIC_o3_v08 / Vertex

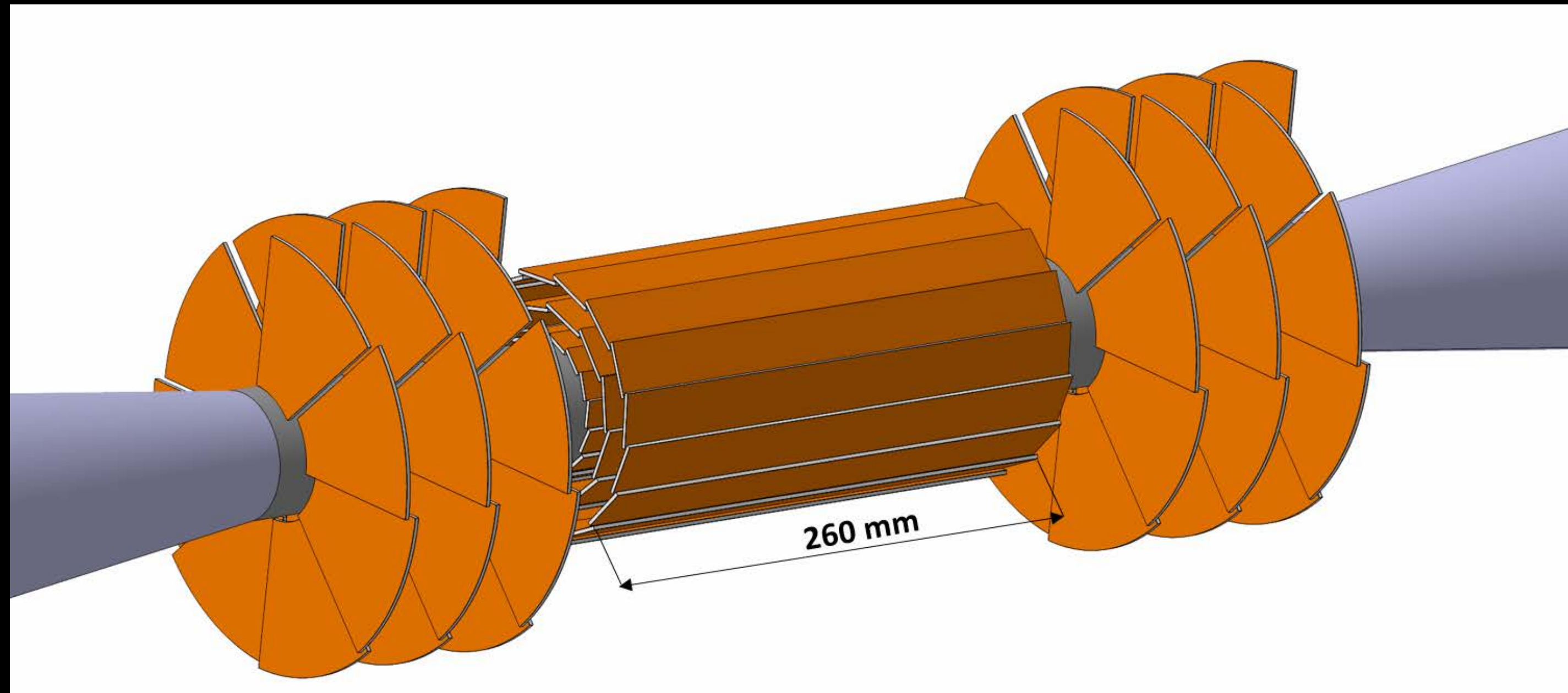

- ★ **barrel**: 3 double layers
 - ★ inner radius: 3.1 cm
 - ★ outer radius: 5.8 cm
 - ★ $25 \times 25 \mu\text{m}^2$ pixels
 - ★ 0.4% X_0 per double layer
- ★ **disks**: 3 disks with 8 petals in spirals
 - ★ inner radius: 3.3 cm
 - ★ outer radius: 10.2 cm

★ VERTEX DETECTOR IN THE SOFTWARE

- ★ reconstructed hits = simulated hits smeared with a Gaussian distribution
- ★ σ smearing in (u,v) = $3 \mu\text{m}$

The detector model: CLIC_o3_v08 / Tracker

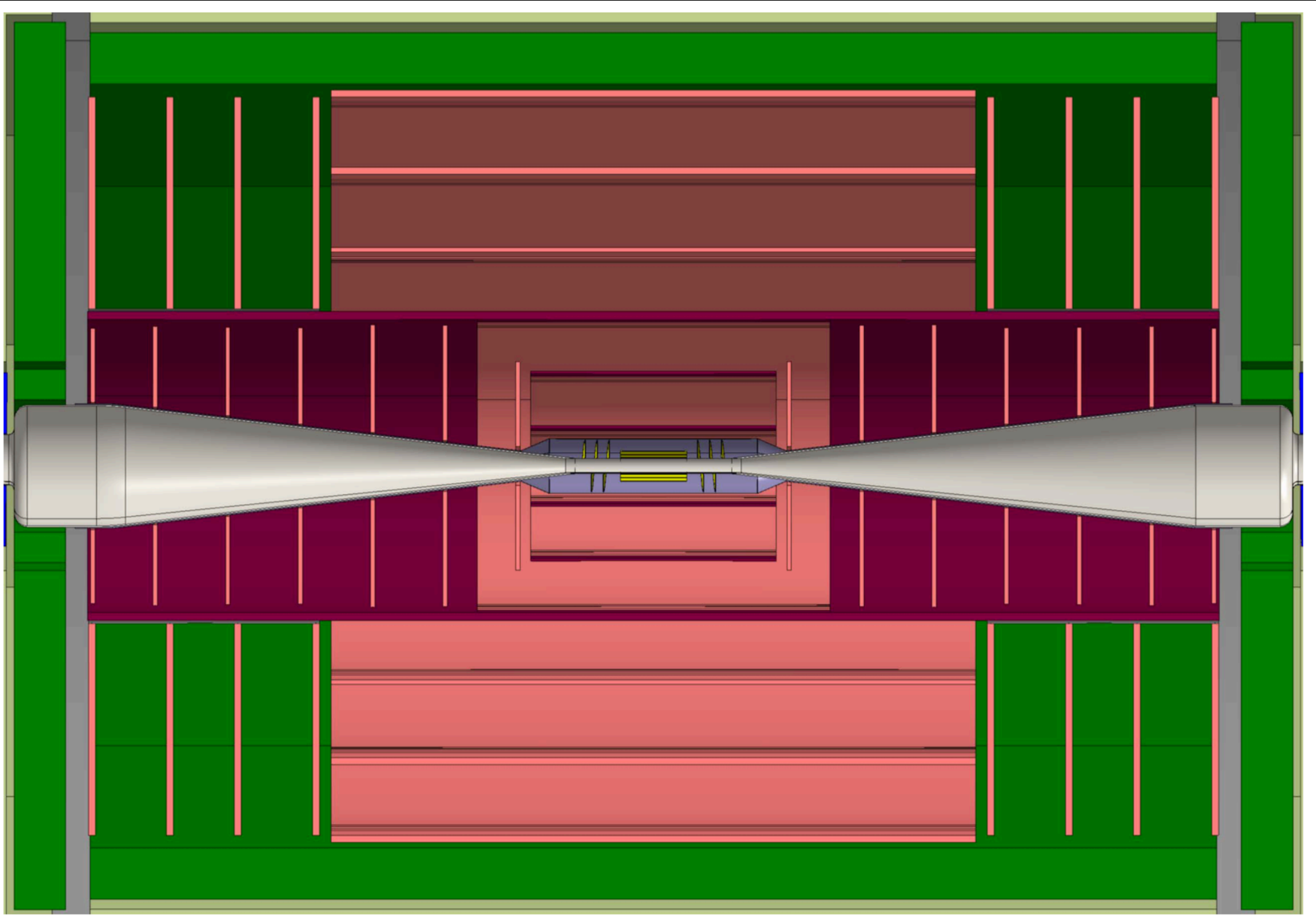

INNER TRACKER

- ★ barrel: 3 layers
- ★ inner radius: 12.7 cm
- ★ outer radius: 55.4 cm
- ★ disks: 7 disks
- ★ z_max: 219 cm

OUTER TRACKER

- ★ barrel: 3 layers
- ★ inner radius: 81.9 cm
- ★ outer radius: 148.6 cm
- ★ disks: 4 disks
- ★ z_max: 219 cm

★ TRACKER DETECTOR IN THE SOFTWARE

- ★ reconstructed hits = simulated hits smeared with a Gaussian distribution
- ★ σ smearing in (u,v) =
 - ★ INNER TRACKER: 7x300 μm (barrel), 5x5 μm (1st disk), 7x300 μm (other disks)
 - ★ OUTER TRACKER: 7x1500 μm (1st barrel), 7x3000 μm (other barrels), 7x3000 μm (disks)

Coverage of the tracking system

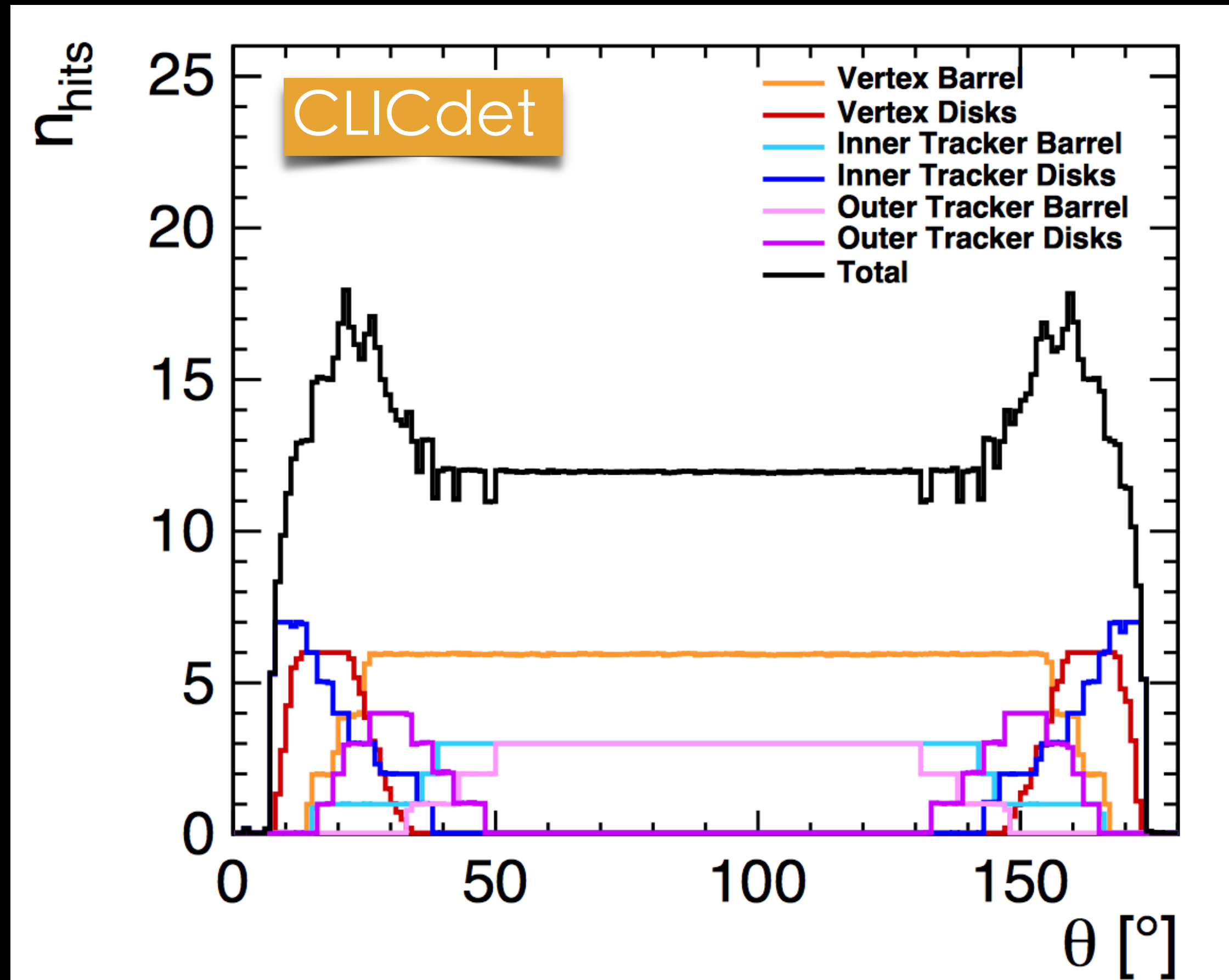

★ θ min (CLICdet) \approx 7 deg

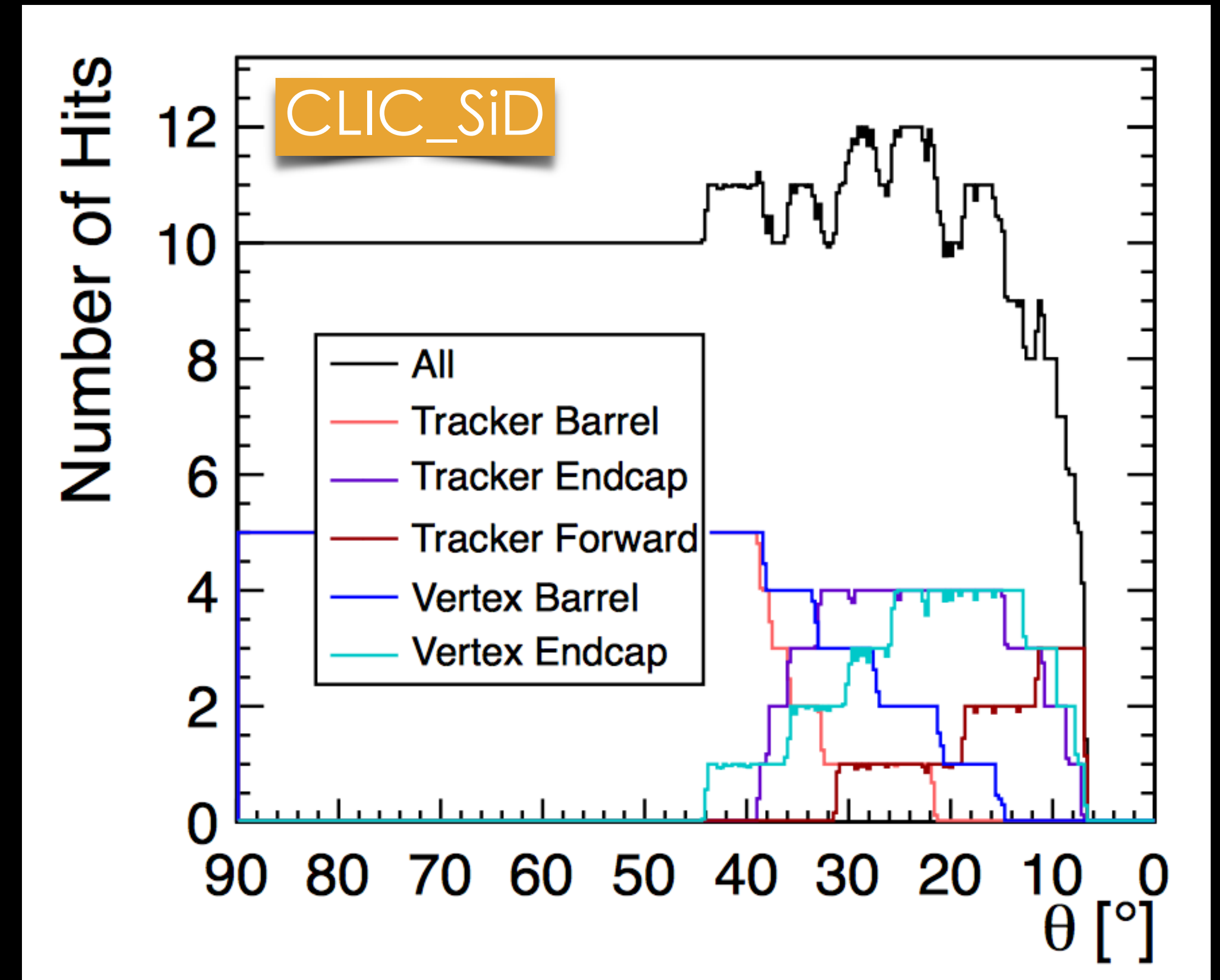

★ θ min (CLIC_SiD) \approx 8 deg

Material budget

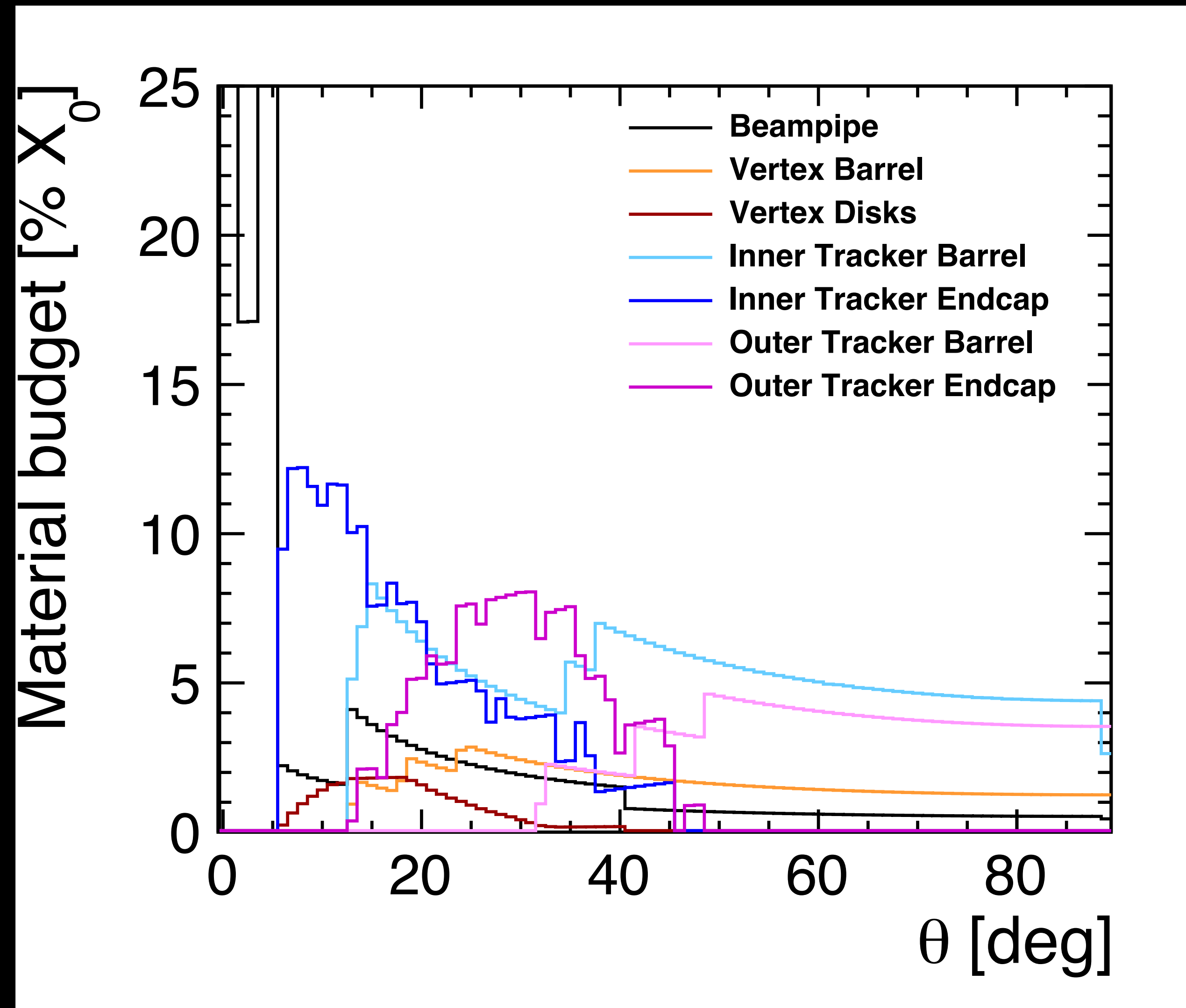

Material budget

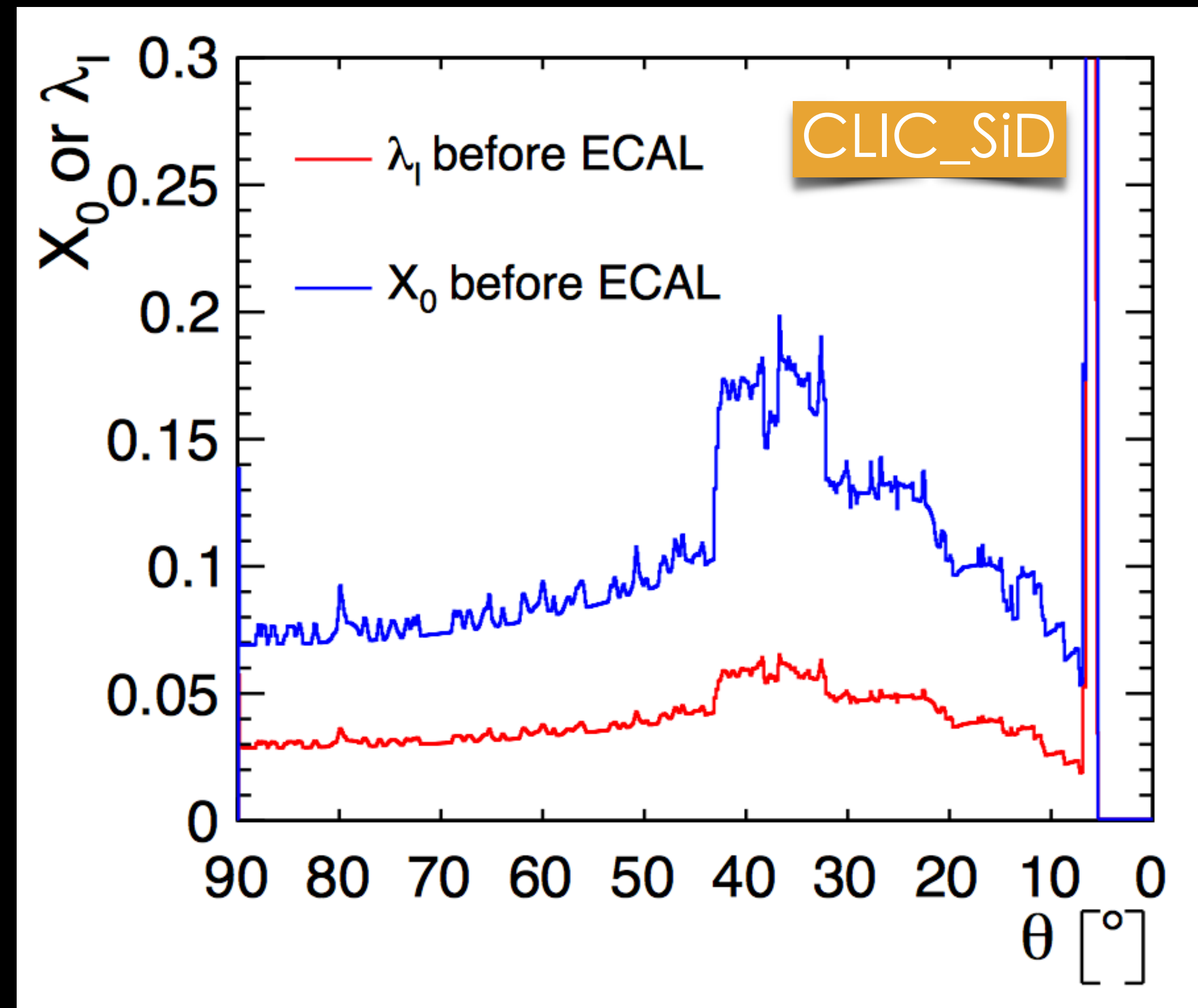
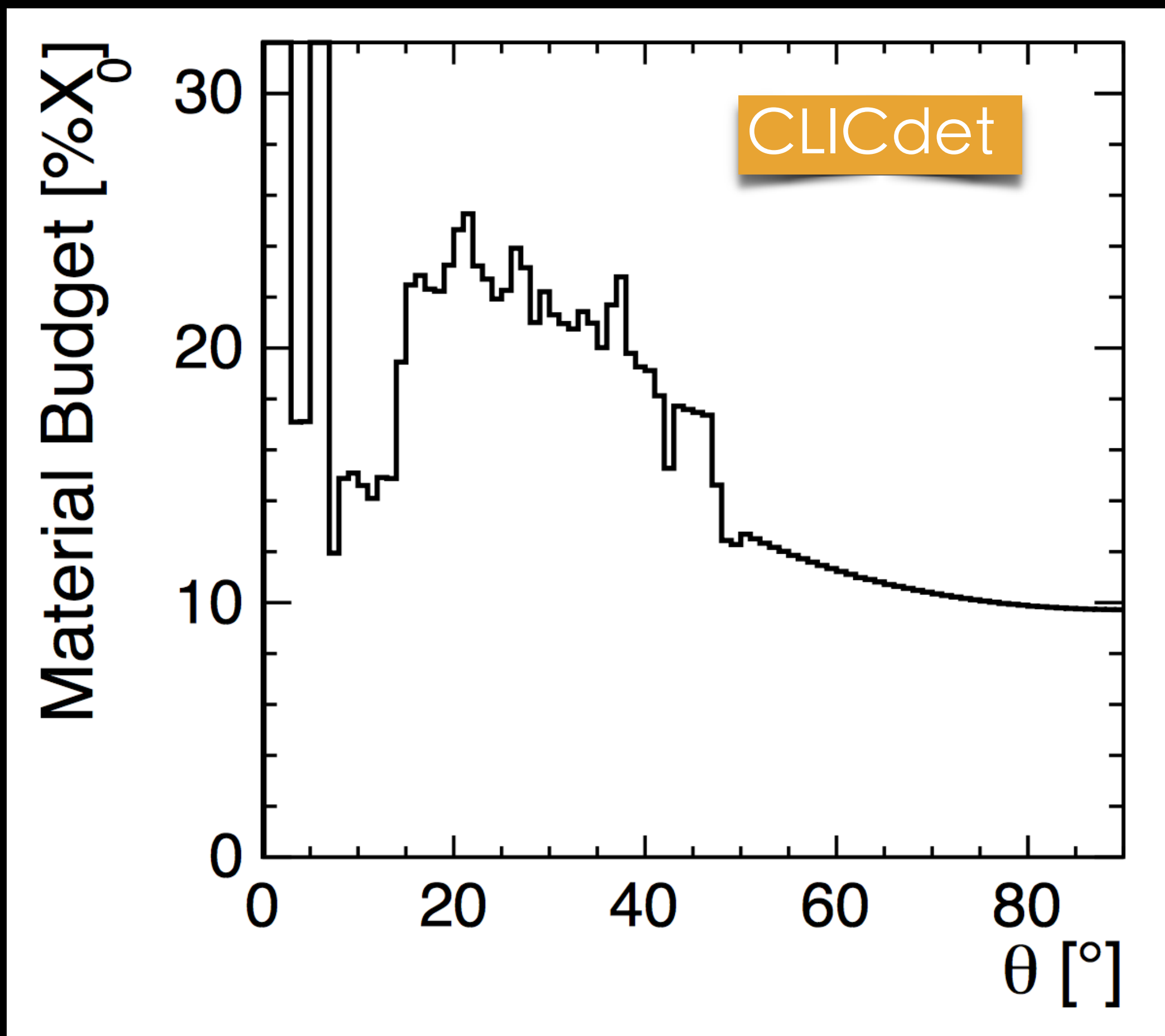

★ CLICdet has additional material wrt CLIC_SiD => higher material budget

Tracking via conformal mapping

<https://indico.cern.ch/event/449801/contributions/1945257/attachments/1213657/1771149/CLICWorkshopDHynds19Jan2016.pdf>

A conformal map of the detector xy plane reduces the pattern recognition to a 2D straight line search, with high p_T tracks pointing towards the origin

$$u = x / (x^2 + y^2)$$
$$v = y / (x^2 + y^2)$$

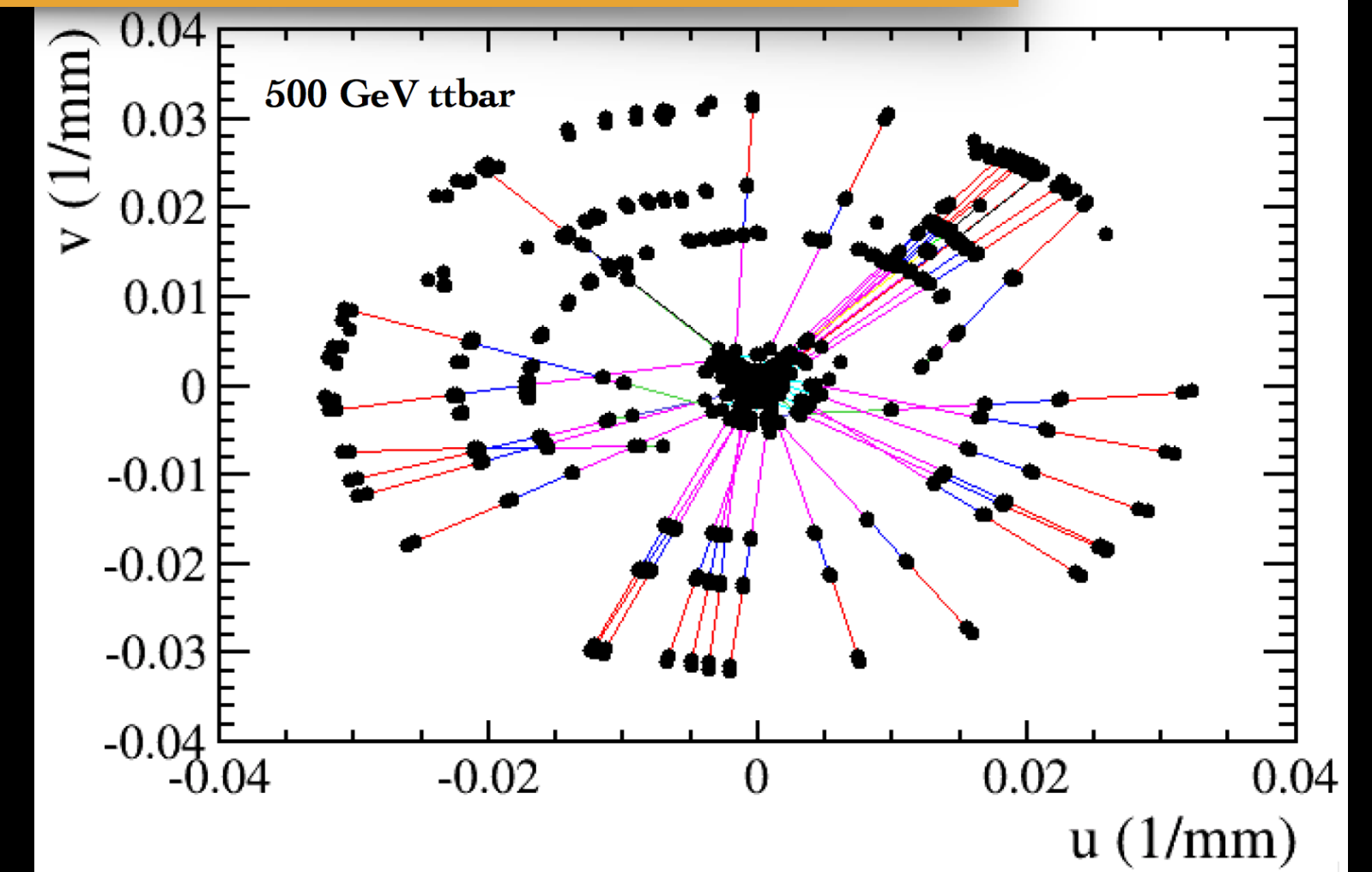

Start from a seed hit and build 'cells'

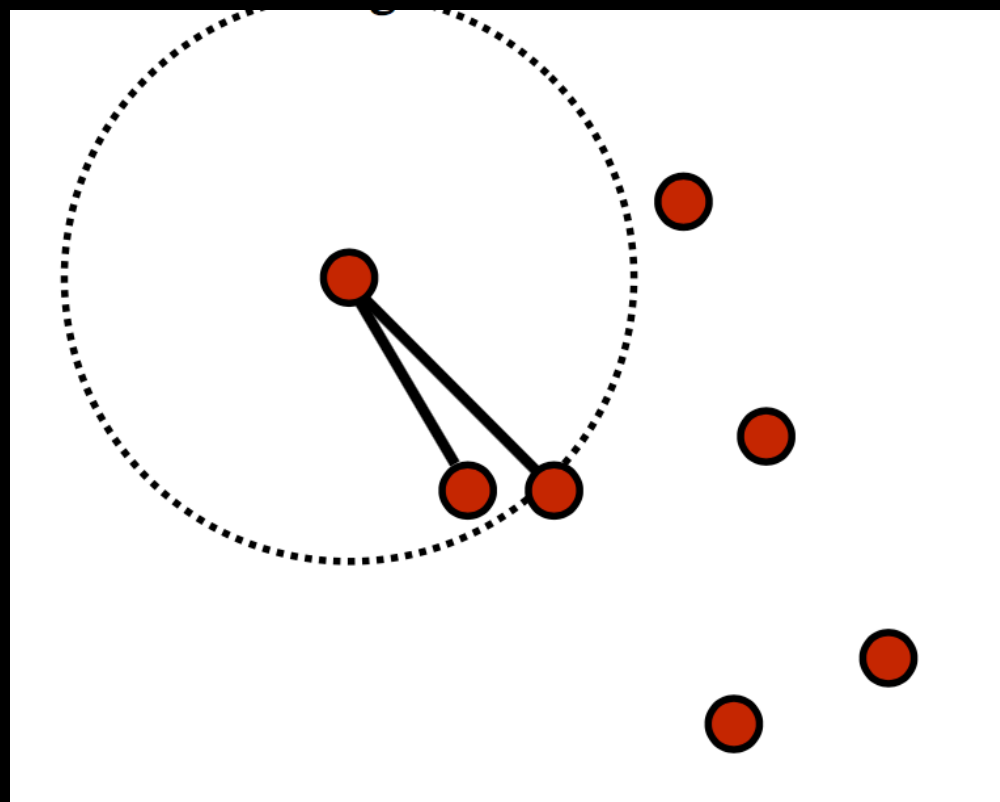

For each cell, extrapolate and take neighbors

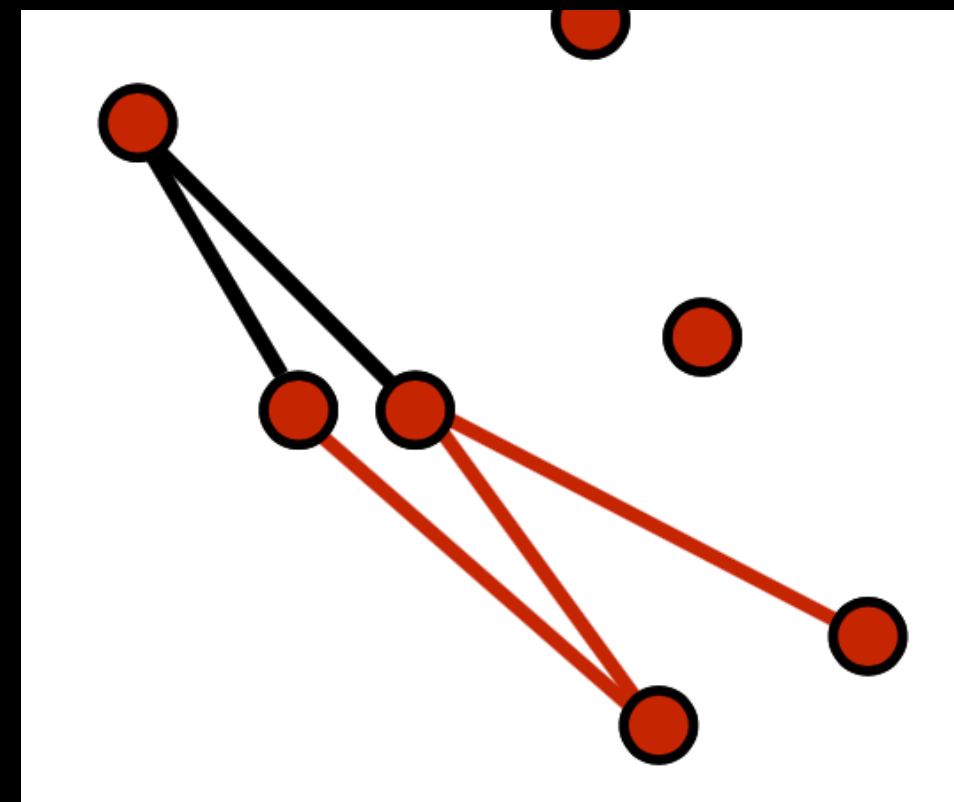

When several possible tracks, min χ^2

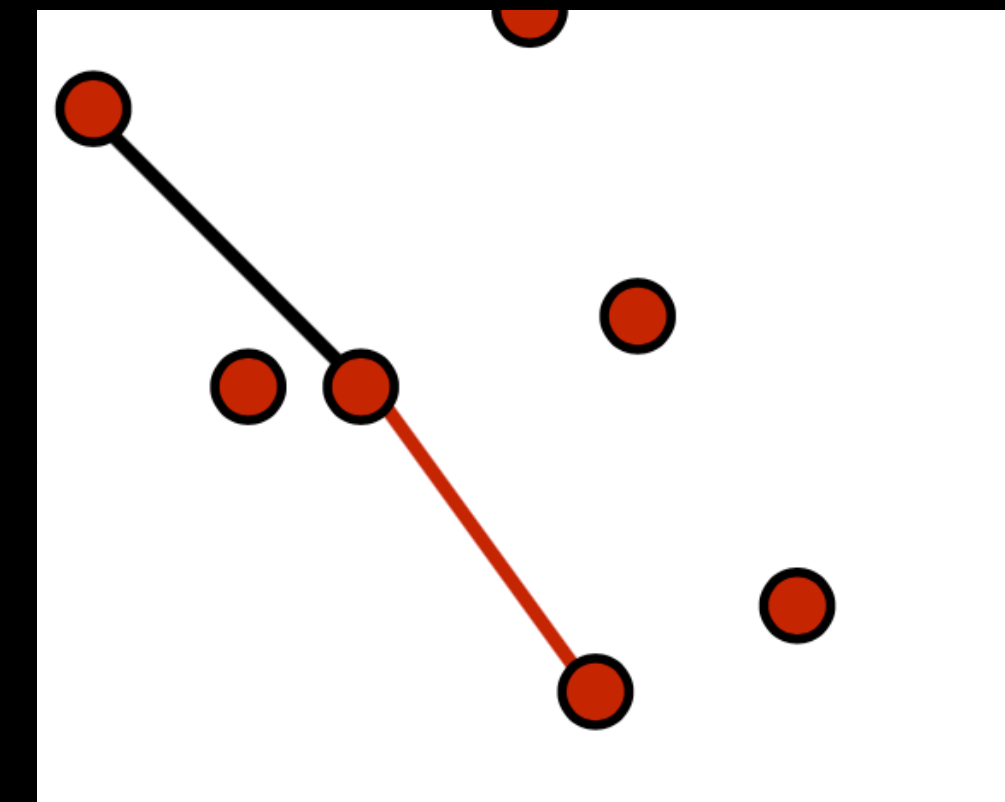

Exclude used hits and continue..

Tracking efficiency for **single muons**

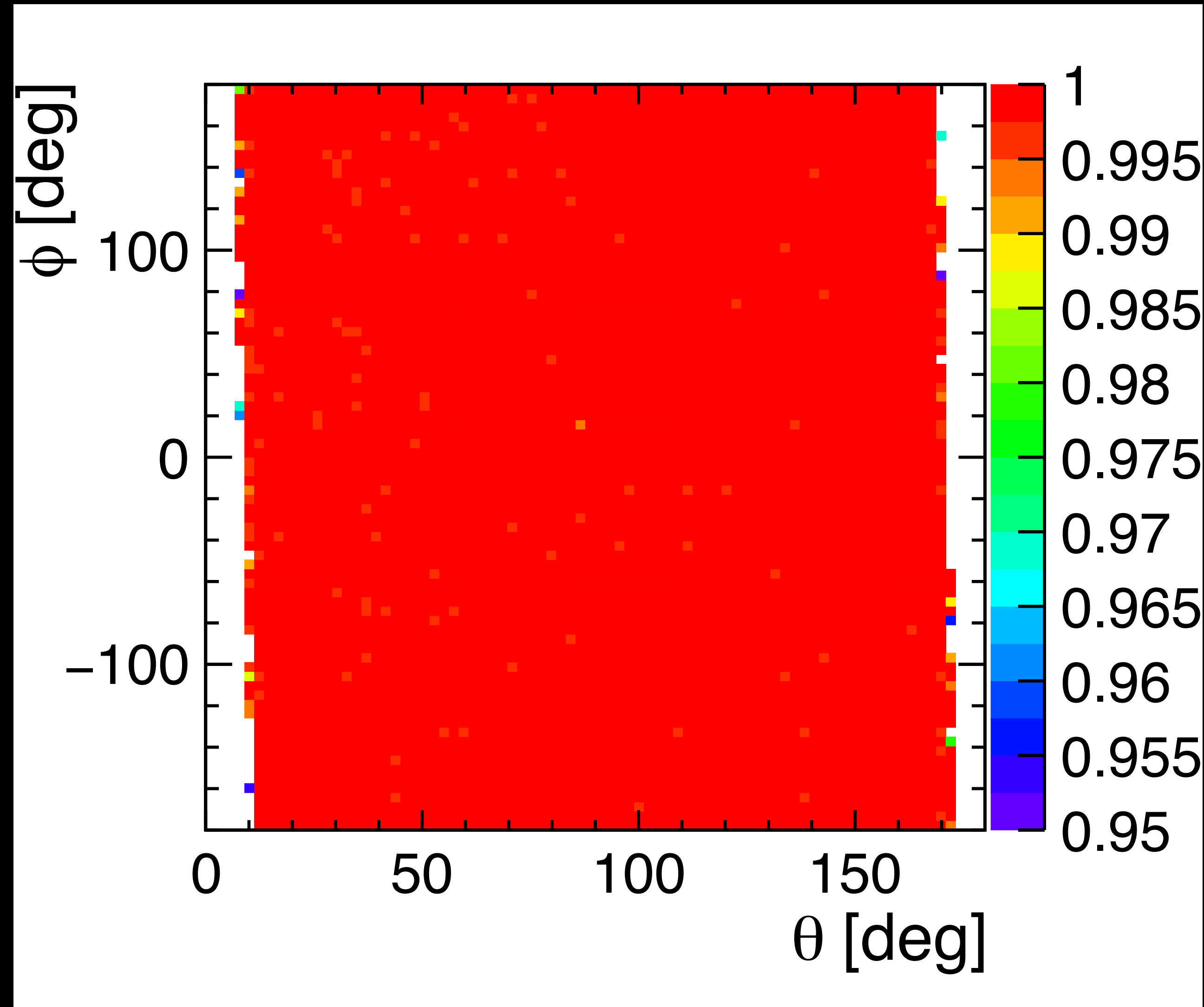

- ★ Muon particle guns at 50 GeV
- ★ Pattern recognition made by **Conformal Tracking** (Vertex Collections) + **Extrapolator** (Inner and Outer Tracker Collections)
- ★ min clusters on track = 4
- ★ fit forward

- ★ Efficiency = $N_{\text{reco}} / N_{\text{sim}}$
- ★ primary particles only

Conformal vs Truth Tracking for muons

Conformal Tracking

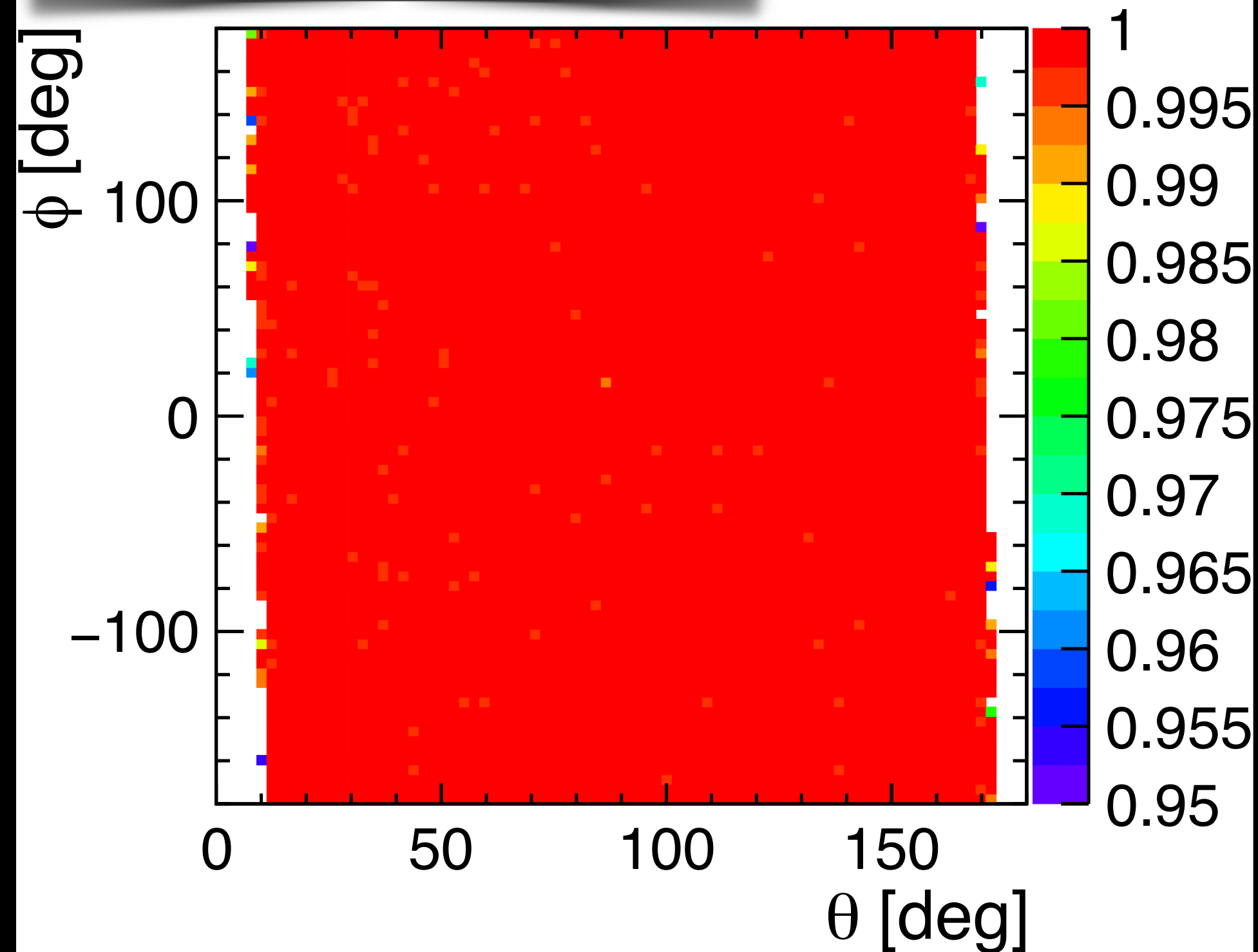

Truth Tracking

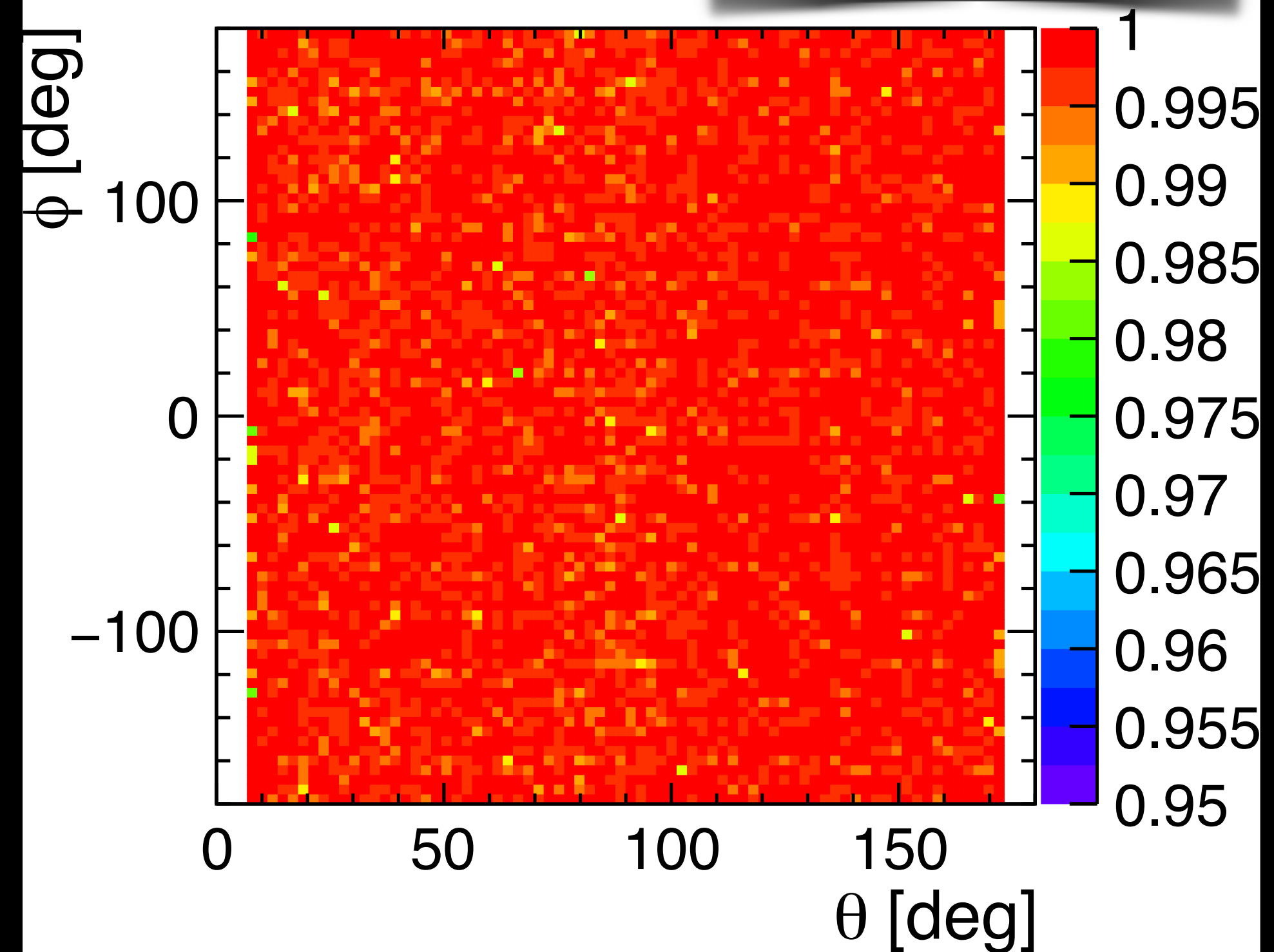

Associates each hit to the corresponding MC particle

- ★ Better efficiency with Conformal Tracking
- ★ possible reason: the Truth Tracking picks the whole set of hits, while the Conformal Tracking might use only (min) 4 of them => in case of very scattered hits, CT performs better than TT

Tracking efficiency for **single electrons**

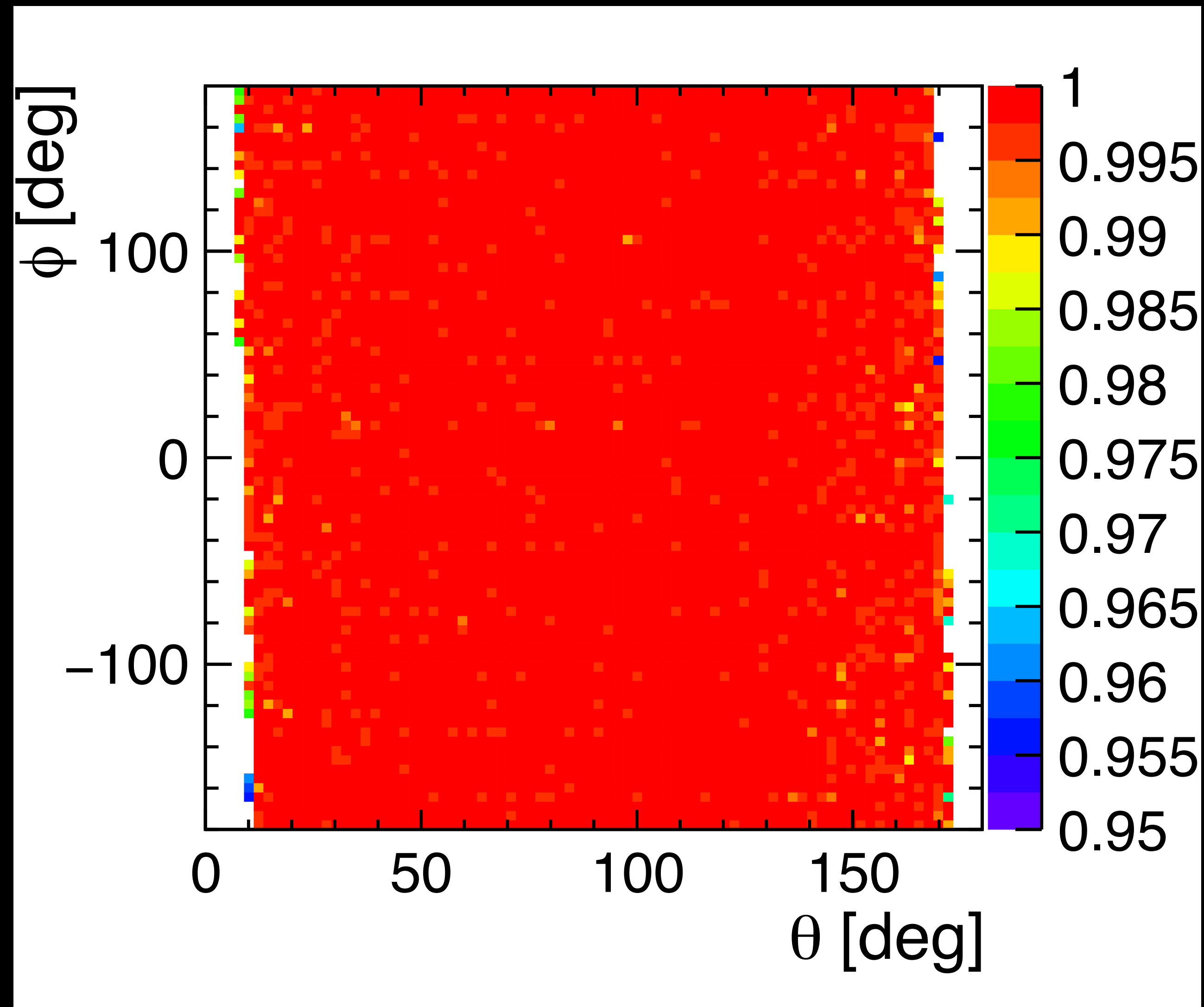

- ★ Electron particle guns at 50 GeV
- ★ Pattern recognition made by **Conformal Tracking** (Vertex Collections) + **Extrapolator** (Inner and Outer Tracker Collections)
- ★ min clusters on track = 4
- ★ fit forward

- ★ Efficiency = $N_{\text{reco}} / N_{\text{sim}}$
- ★ primary particles only

Conformal vs Truth Tracking for electrons

Conformal Tracking

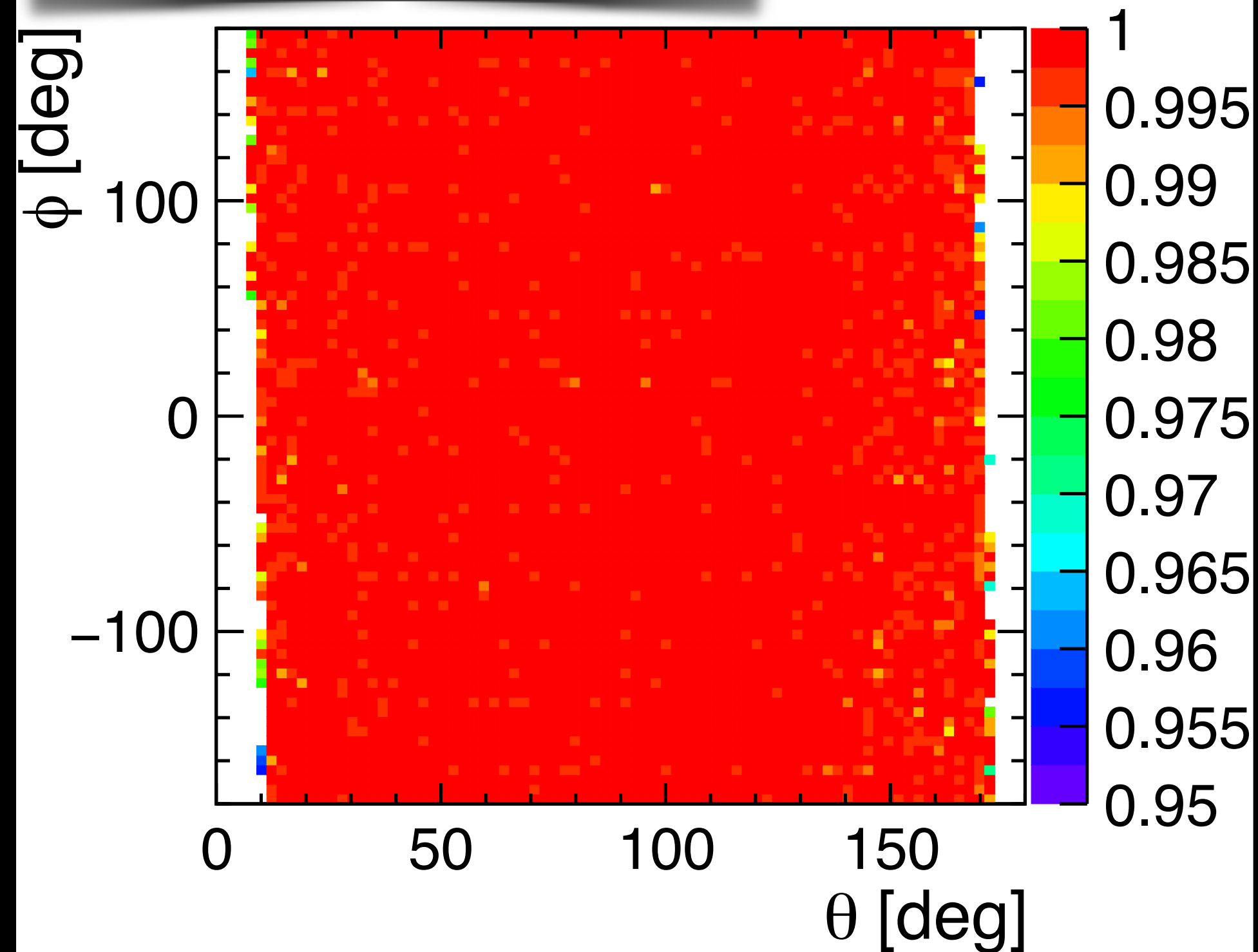

Truth Tracking

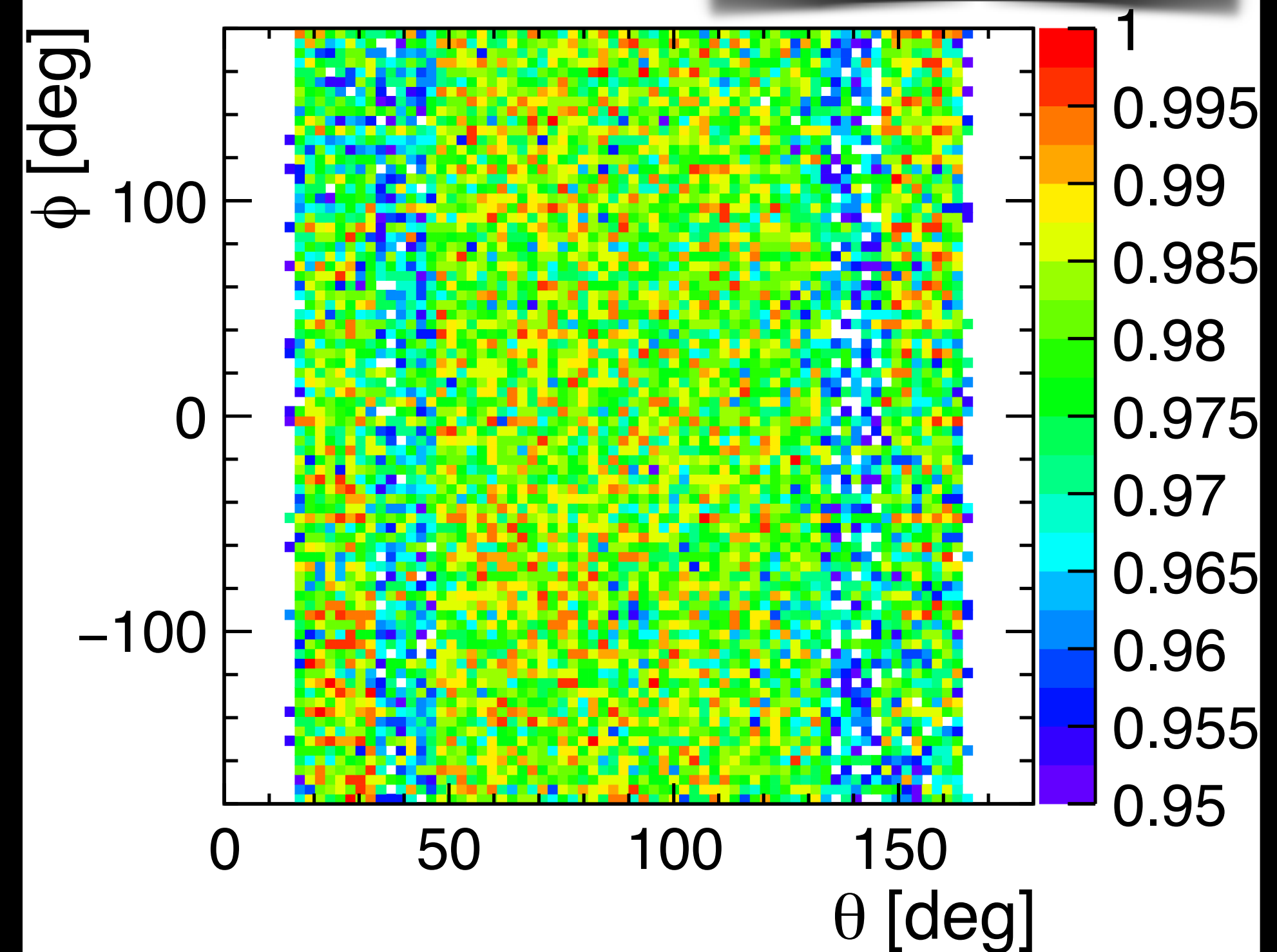

- ★ Better efficiency with Conformal Tracking [even more relevant for electrons]
- ★ possible reason: the Truth Tracking picks the whole set of hits, while the Conformal Tracking might use only (min) 4 of them => in case of very scattered hits, CT performs better than TT

Momentum resolution

- ★ Muon Geant4 particle guns
- ★ fixed p , fixed θ

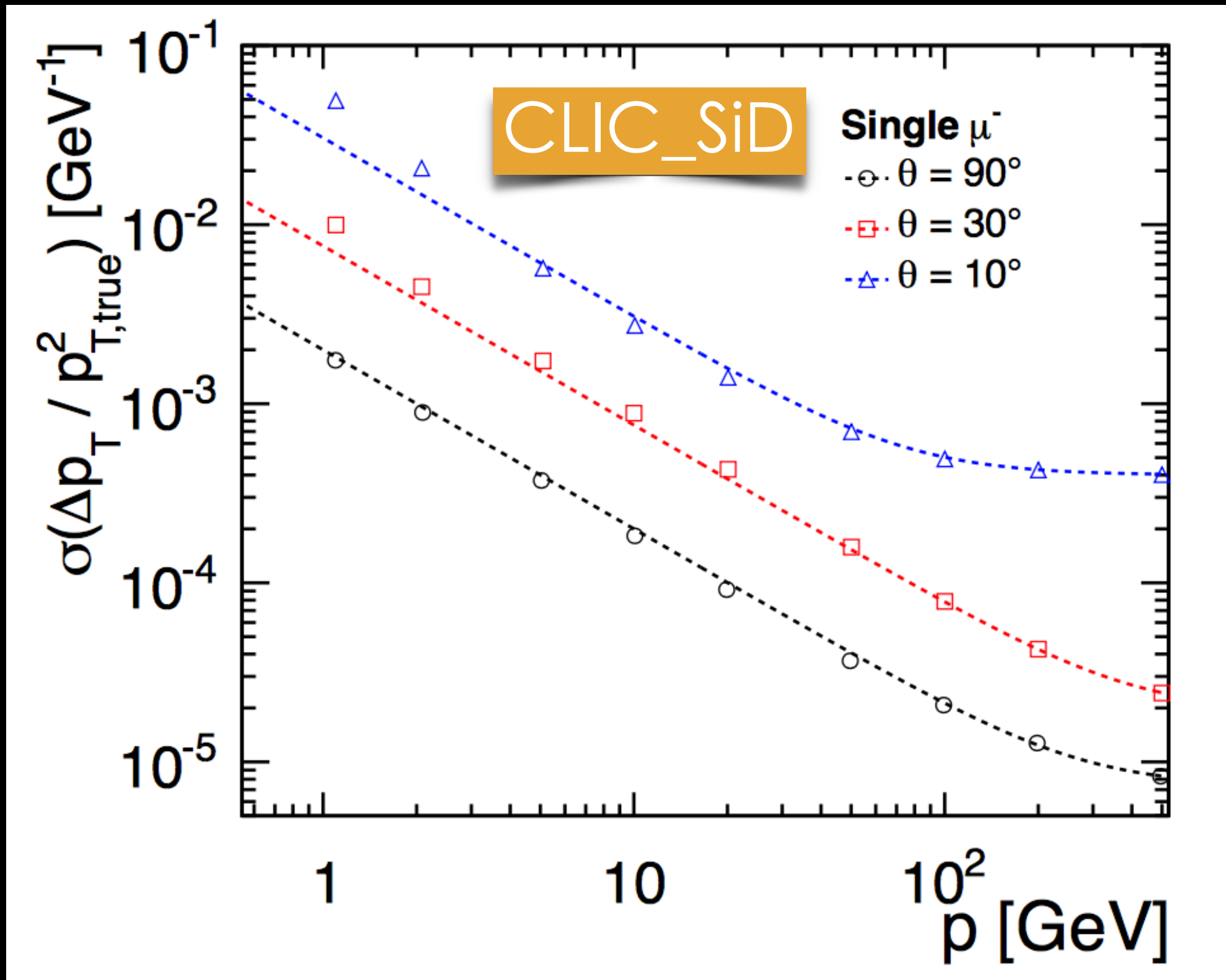
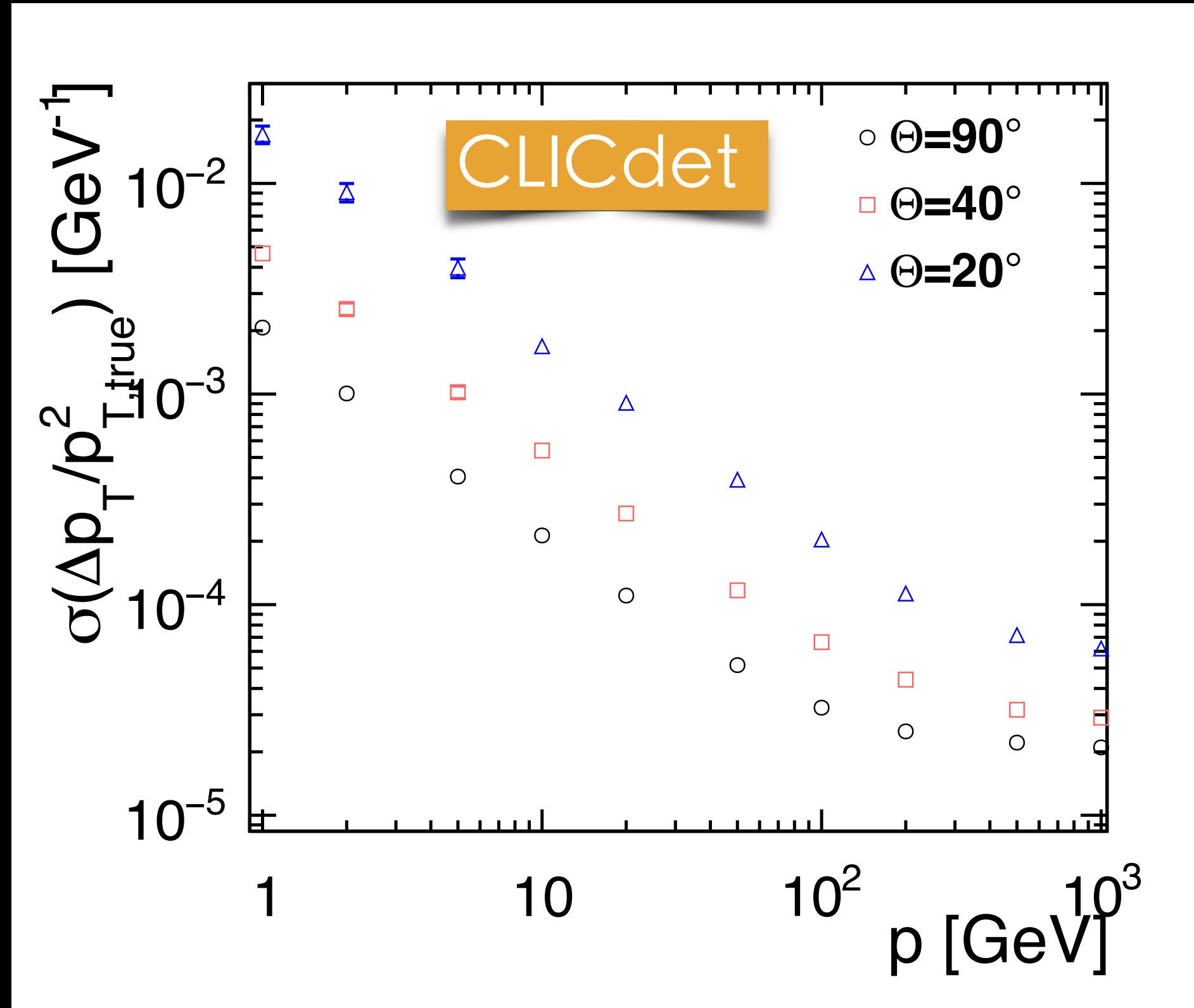

- ★ $\theta = 90$ deg, high p \rightarrow CLICdet slightly worse resolution than CLIC_SiD
- ★ different geometry, B field (5T for _SiD) and digitization
- ★ low p \rightarrow CLICdet seems better than CLIC_SiD

Momentum resolution

- ★ Muon Geant4 General Particle Source
- ★ linear p distribution, fixed θ

$$\sigma(\Delta p_T/p_T^2) = a \oplus \frac{b}{p_T} = a \oplus \frac{b}{p \sin \theta}$$

curvature \rightarrow a \rightarrow b multiple scattering

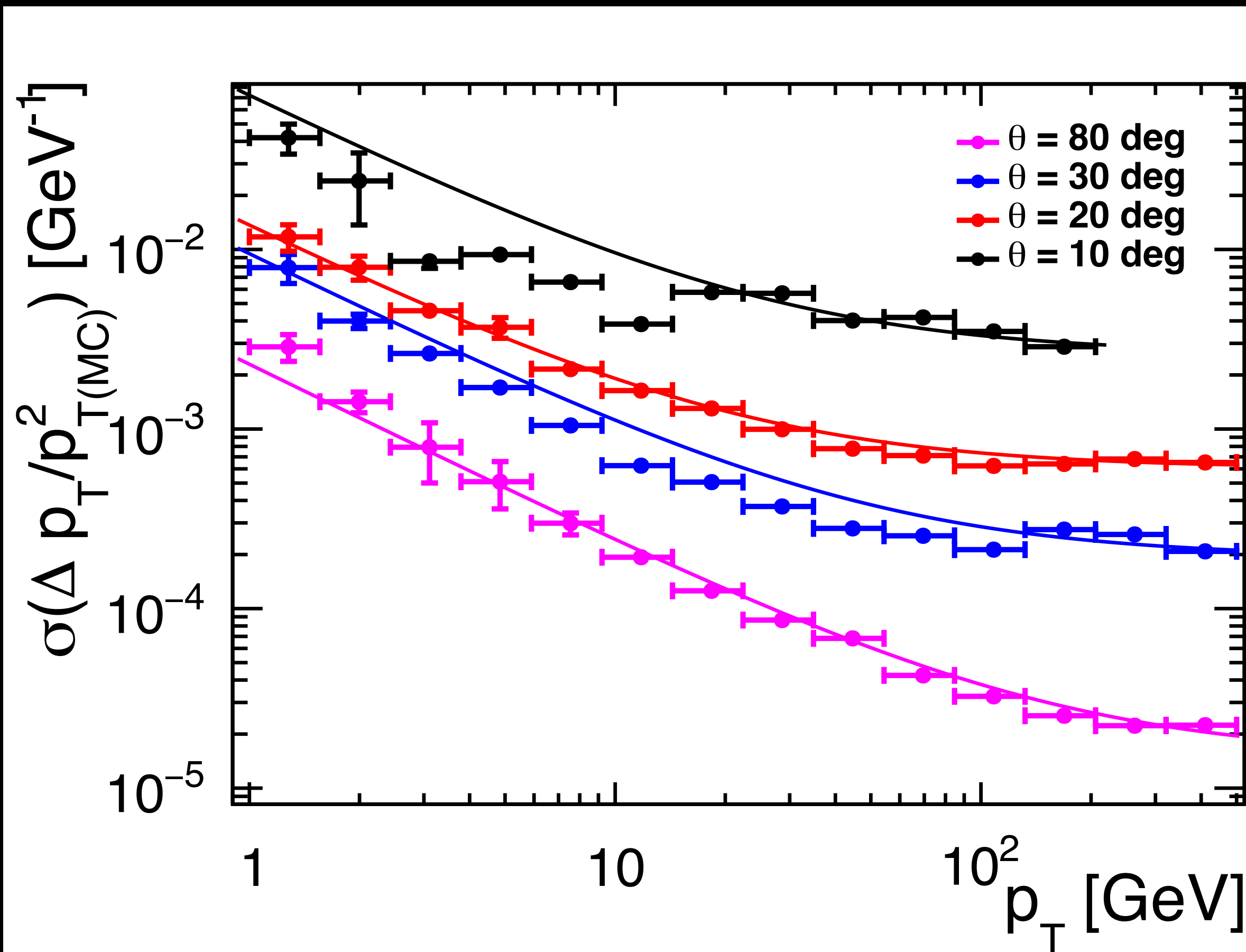

CLICdet

θ	a [GeV^{-1}]	b
10	2.6×10^{-3}	6.9×10^{-2}
20	6×10^{-4}	1.3×10^{-2}
30	1.9×10^{-4}	9.3×10^{-3}
80	1.5×10^{-5}	2.3×10^{-3}

CLIC_SiD

θ	a [GeV^{-1}]	b
10	4.0×10^{-4}	2.0×10^{-3}
30	1.9×10^{-5}	3.8×10^{-3}
90	7.3×10^{-6}	2.0×10^{-3}

Angular resolution

- ★ Muon Geant4 General Particle Source
- ★ linear p distribution, fixed θ

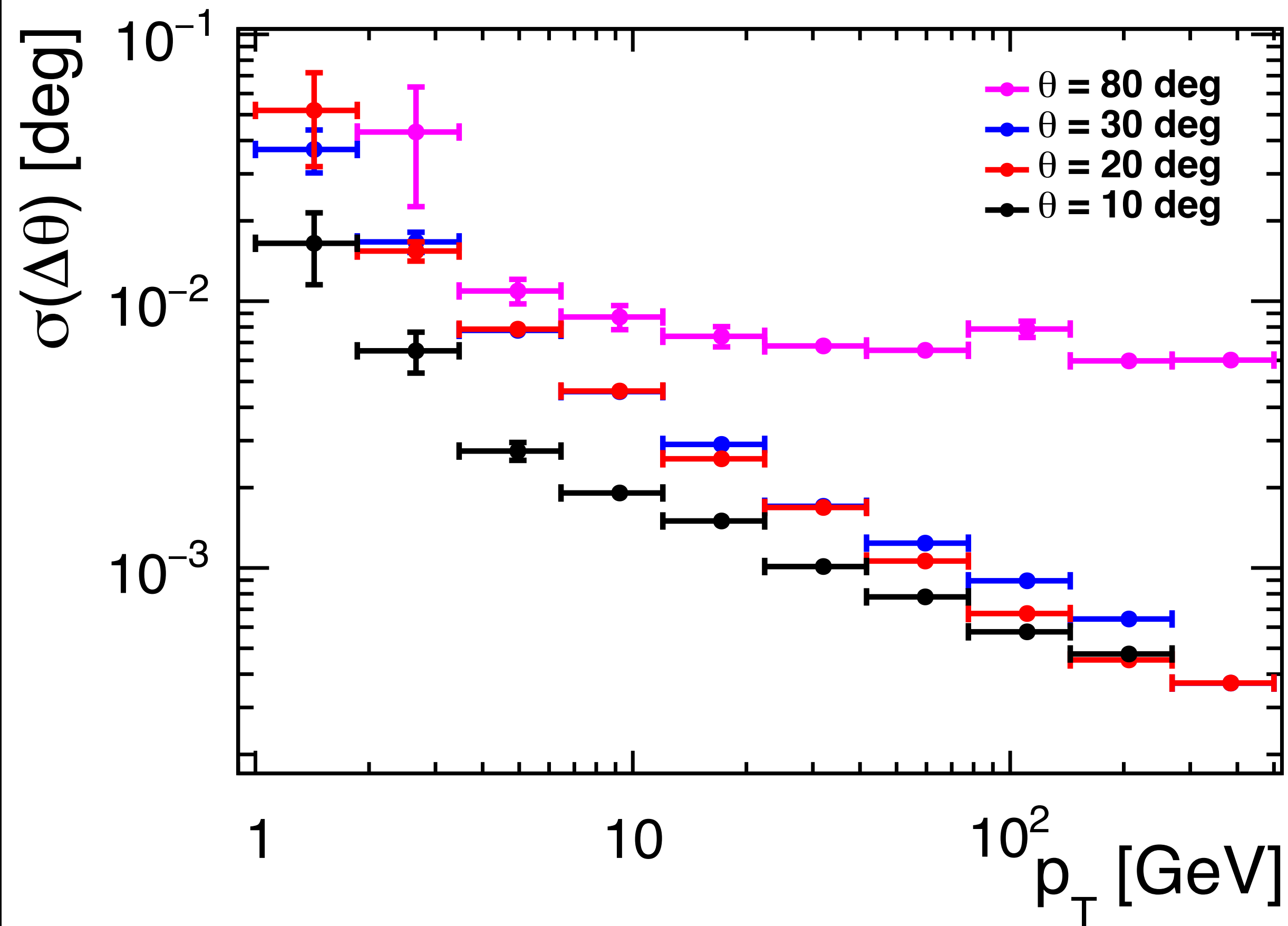

- ★ Better angular resolution in forward
- ★ may be due to the higher lever of the forward tracks

Summary and Outlook

- ★ Tested CLICdet_o3_v08
- ★ Validated simulation and reconstruction in the vertex + tracker
 - ★ both Conformal and Truth Tracking
- ★ First performance results available
 - ★ material budget, tracking efficiency, momentum/angular resolution

- ★ Optimization of the current results
- ★ Study of performance of displaced tracks
 - ★ tracking efficiency for ttbar, bbbar events

THANK YOU

BACKUP

CLIC_SiD [CDR]

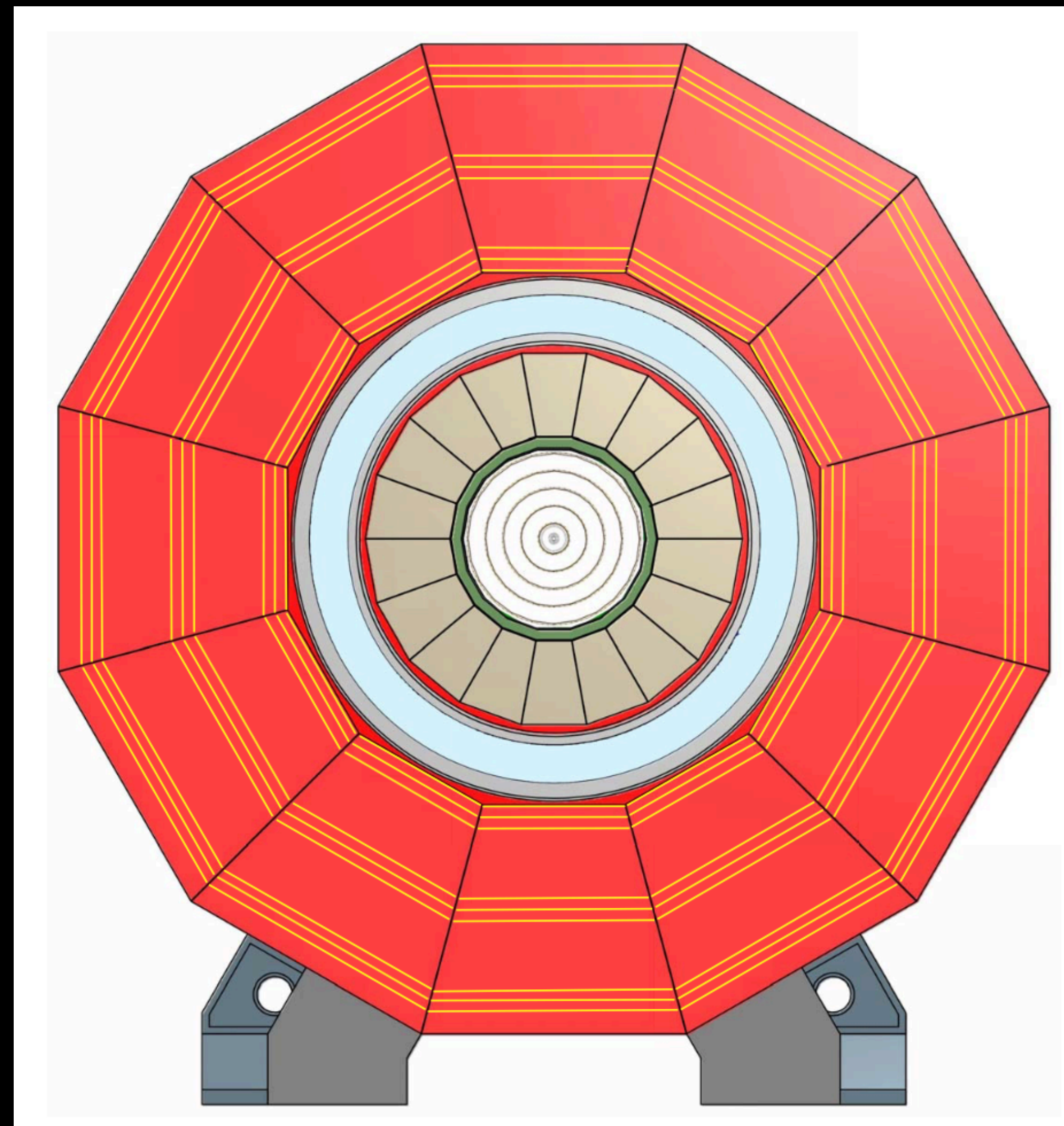
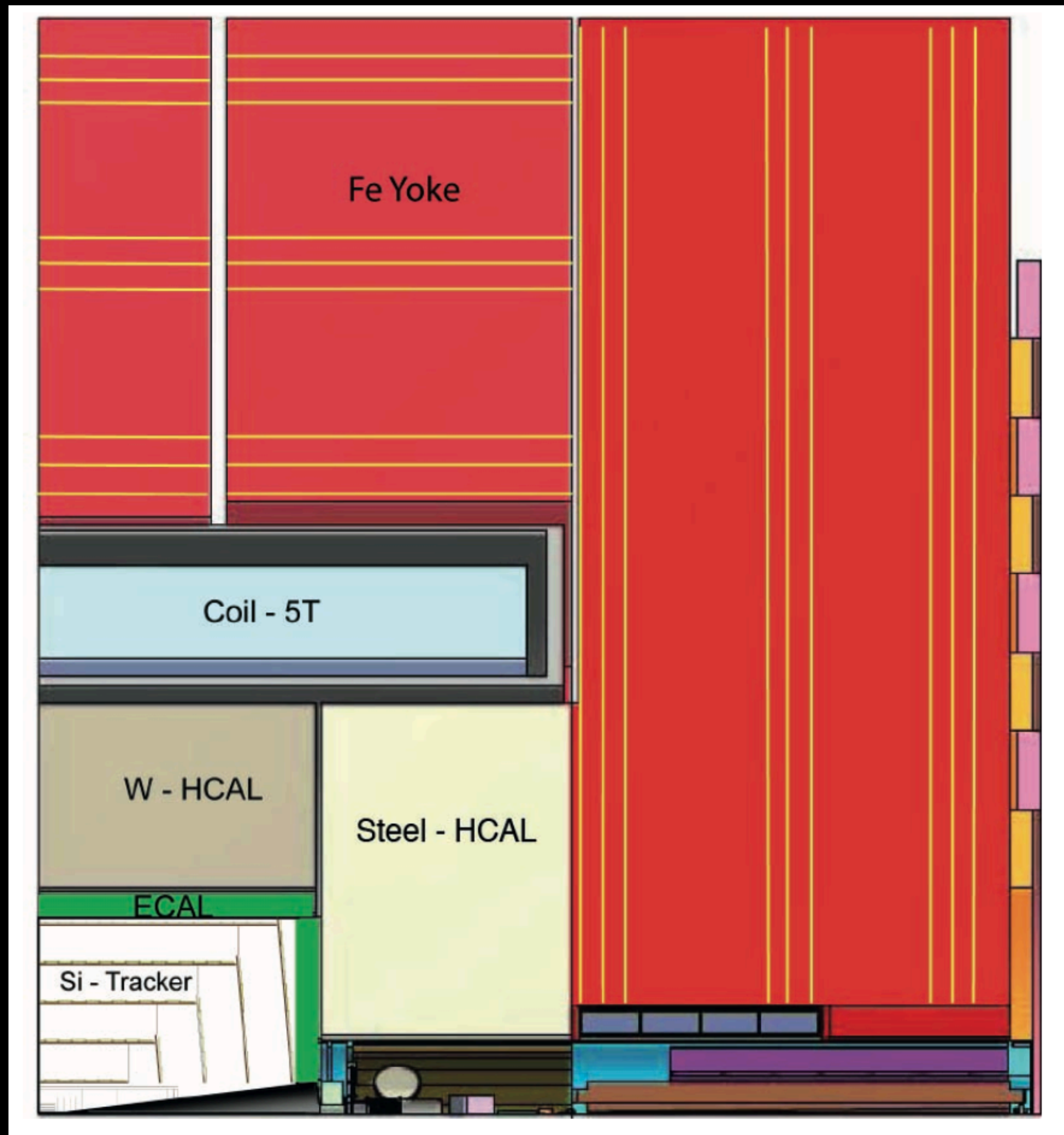

Momentum resolution / Gaussian fits

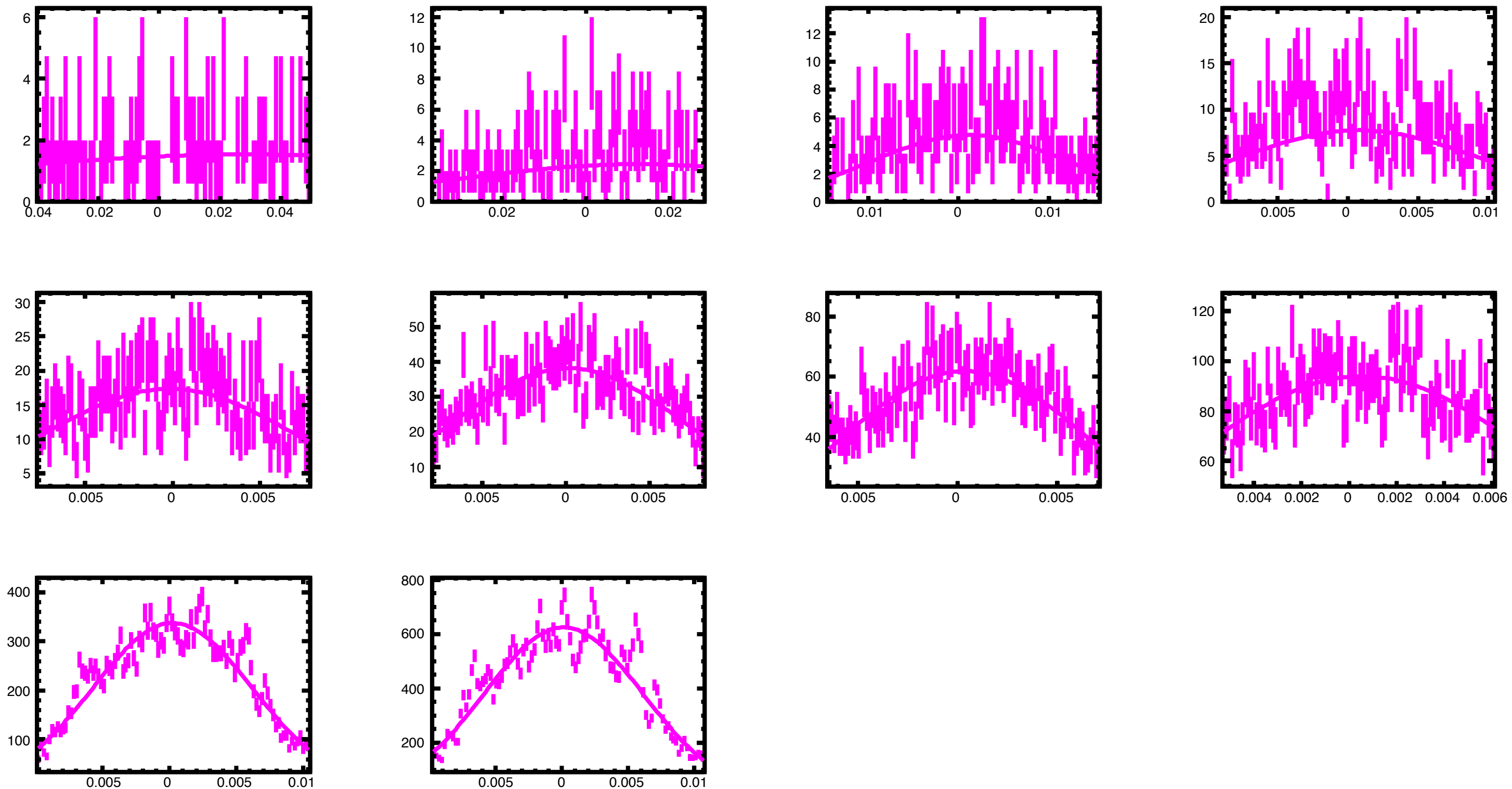

$\theta = 80\text{deg}$

Momentum resolution / Gaussian fits

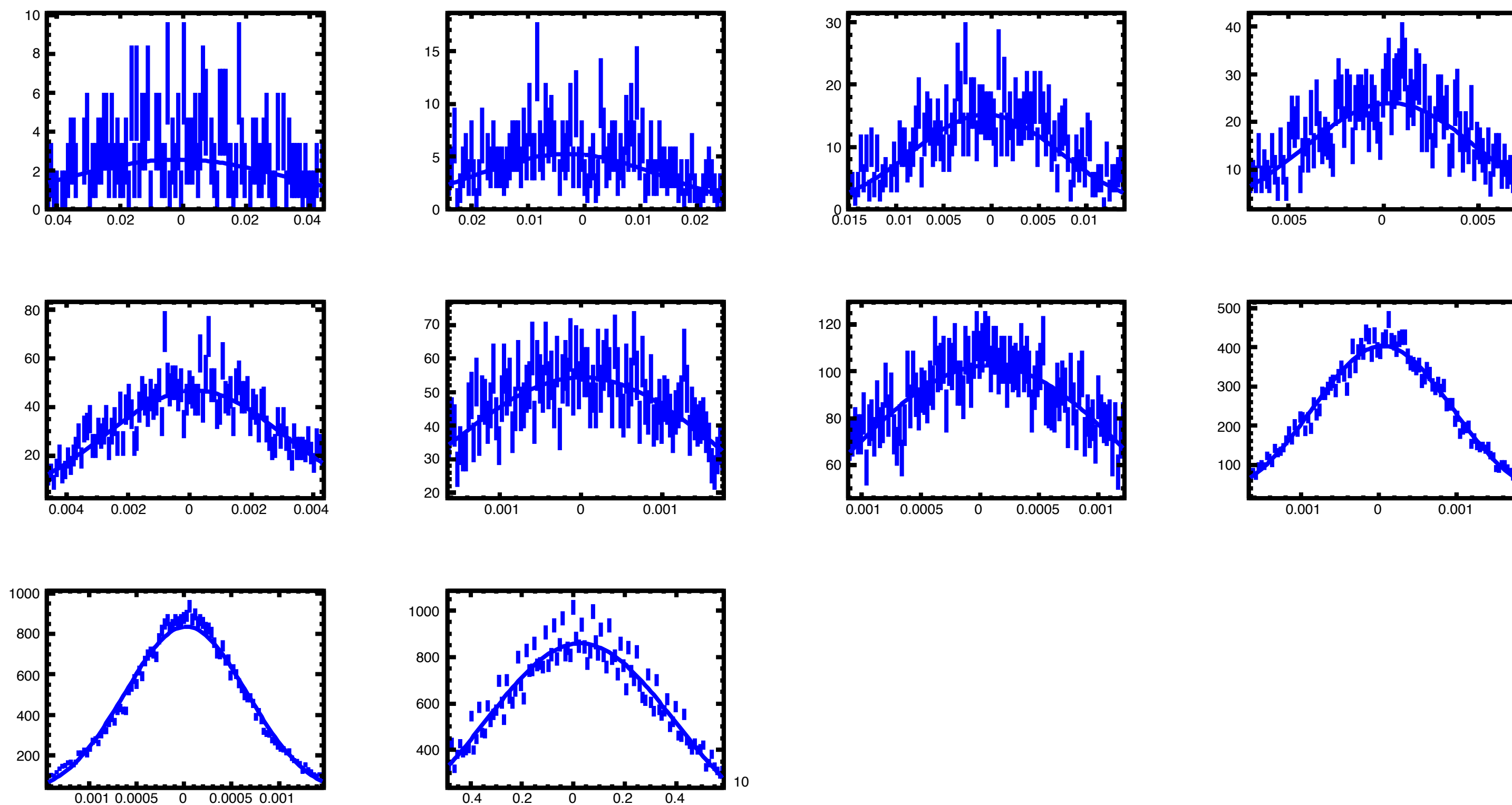

$\theta = 30\text{deg}$

Momentum resolution / Gaussian fits

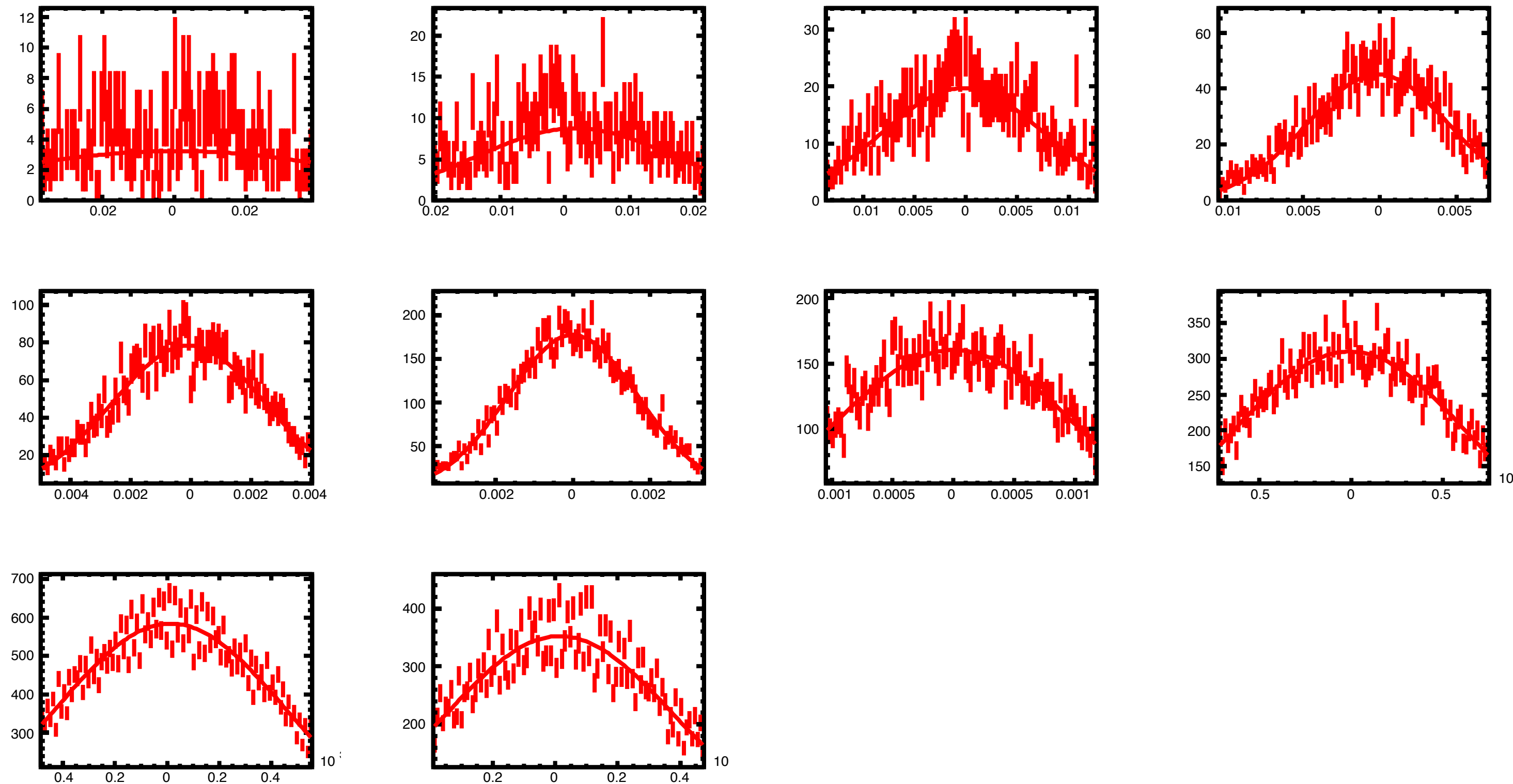

$\theta = 20\text{deg}$

Momentum resolution / Gaussian fits

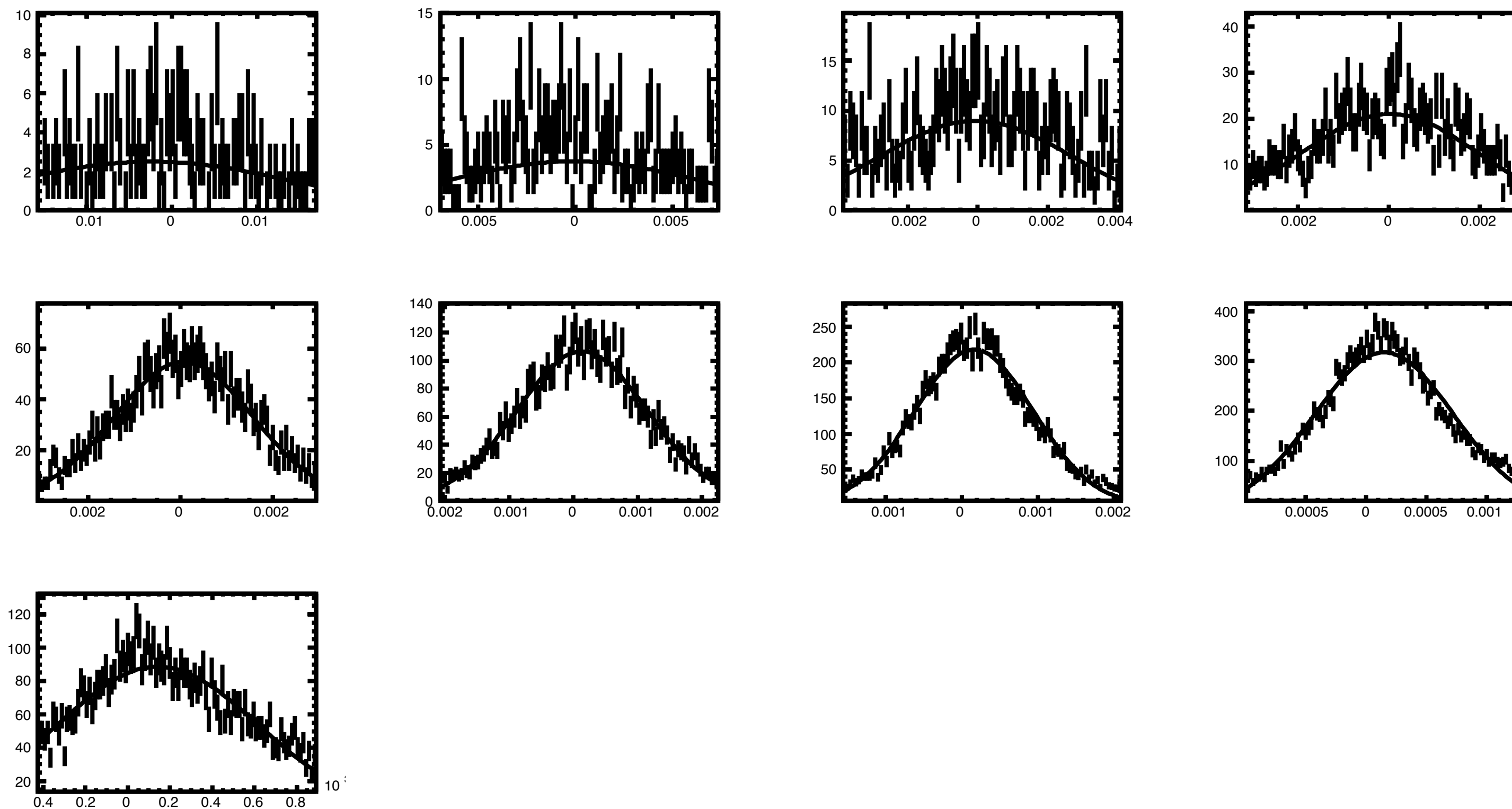

$\theta = 10\text{deg}$