

Optimisation of the Drive Beam Recombination Complex

Raul Costa

CERN

March 6, 2017

CLIC Workshop 2017, Geneva, Switzerland

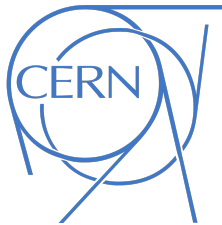

universidade de aveiro



Raul Costa, Andrea Latina, Eduardo Marin

DBRC's role

The DBRC is located after the drive beam linac. It's main role is to create high current pulses for the PETS.

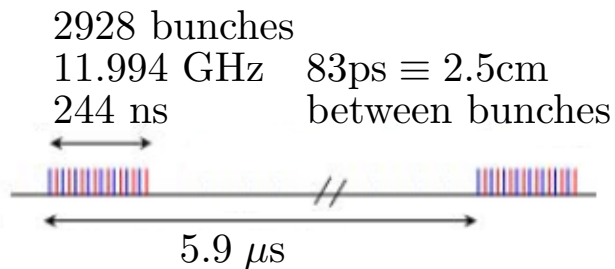
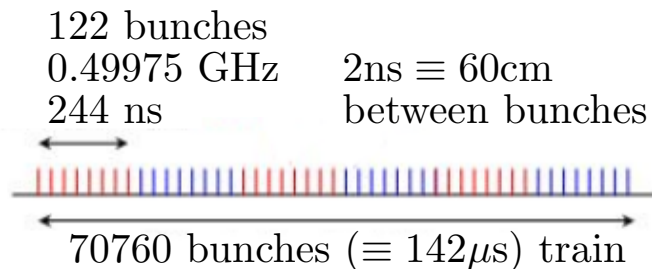
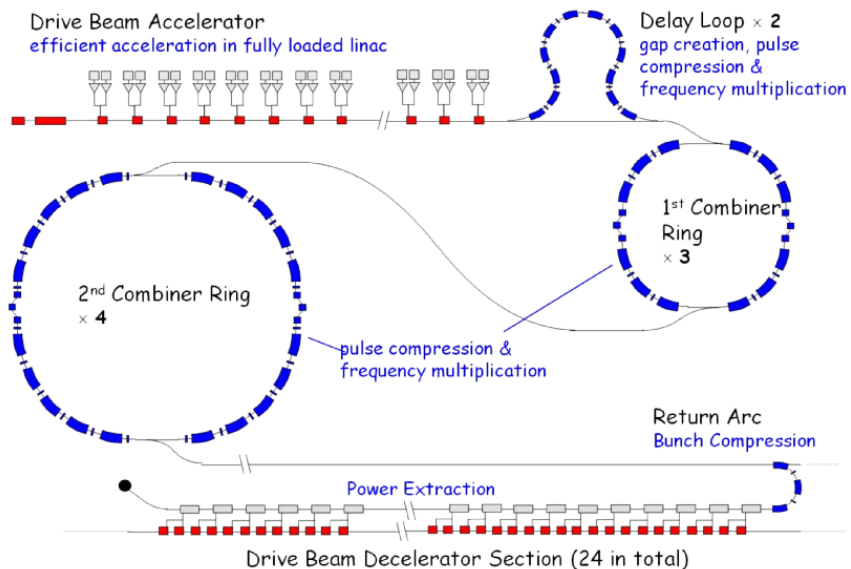

DBRC's design parameters

Injection:

- $E = 2.38\text{GeV}$
- $\Delta E = 0.85\%$
- $\varepsilon_{x,y} = 100\mu\text{m}$
- $\sigma_z = 1\text{mm}^1$
- Longitudinal chirp
- $f = 0.49975\text{GHz}$
- 122 bunch trains
phase-coded

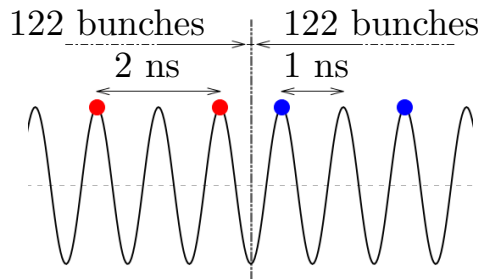

Extraction:

- $E = 2.38\text{GeV}$
- $\Delta E = 0.85\%$
- $\varepsilon_{x,y} = 150\mu\text{m}$
- $\sigma_z = 1\text{mm}$
- Longitudinal chirp
- $f = 11.994\text{GHz}$
- short pulse time structure

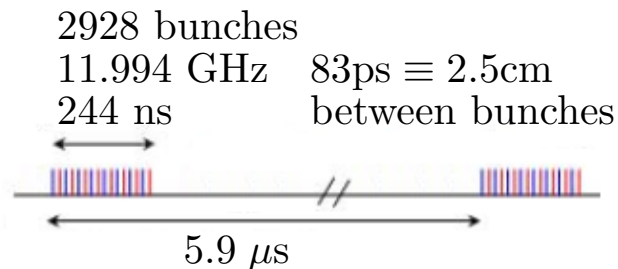

¹2mm inside the complex

Transverse Emittance

Because we have different bunches taking different paths:

- They may not all be centred at extraction
- They may not all have the same twiss
- Individual or average emittances are not the best figure of merit
- We can project all bunches into one and compute the train emittance from there

Combiner Ring 1:

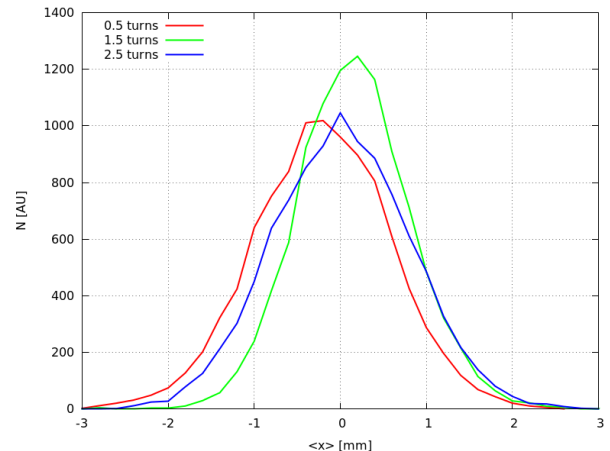
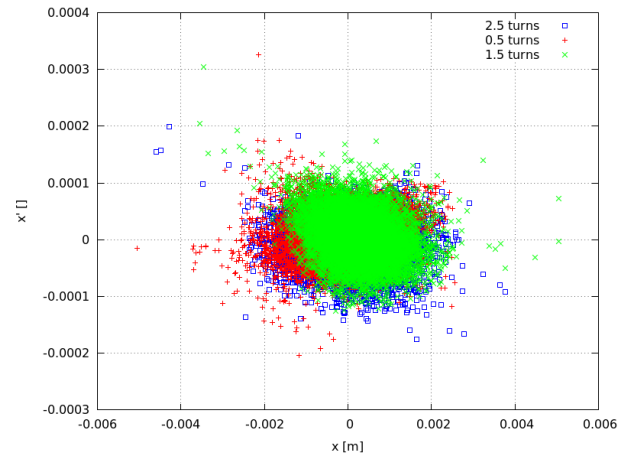

Longitudinal chirp - T_{566} aberration

- Placet2 tracking showed a strong T_{566} aberration
- Identified has a longitudinal effect of divergence
- Corrected using sextupoles in dispersive regions

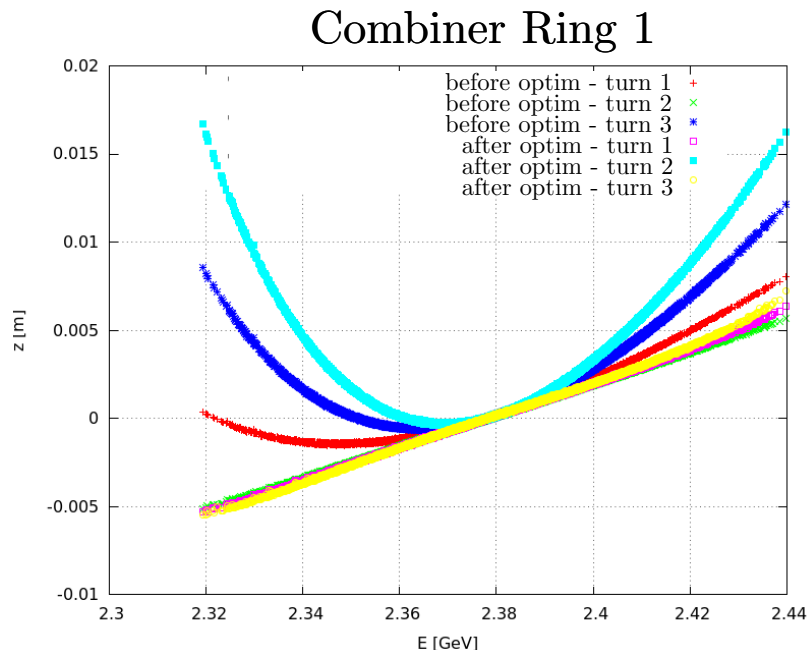

$$Z_{\text{Drift}} \sim Z_0 + L \frac{x'^2 + y'^2}{2} \propto Z_0 + L(\Delta E)^2$$

CR2 injection scheme

- CR2 uses two 3 GHz RF kickers to inject the bunches into orbit
- This means that the third turn of the ring suffers a "bump" in the opposite direction of the septum.

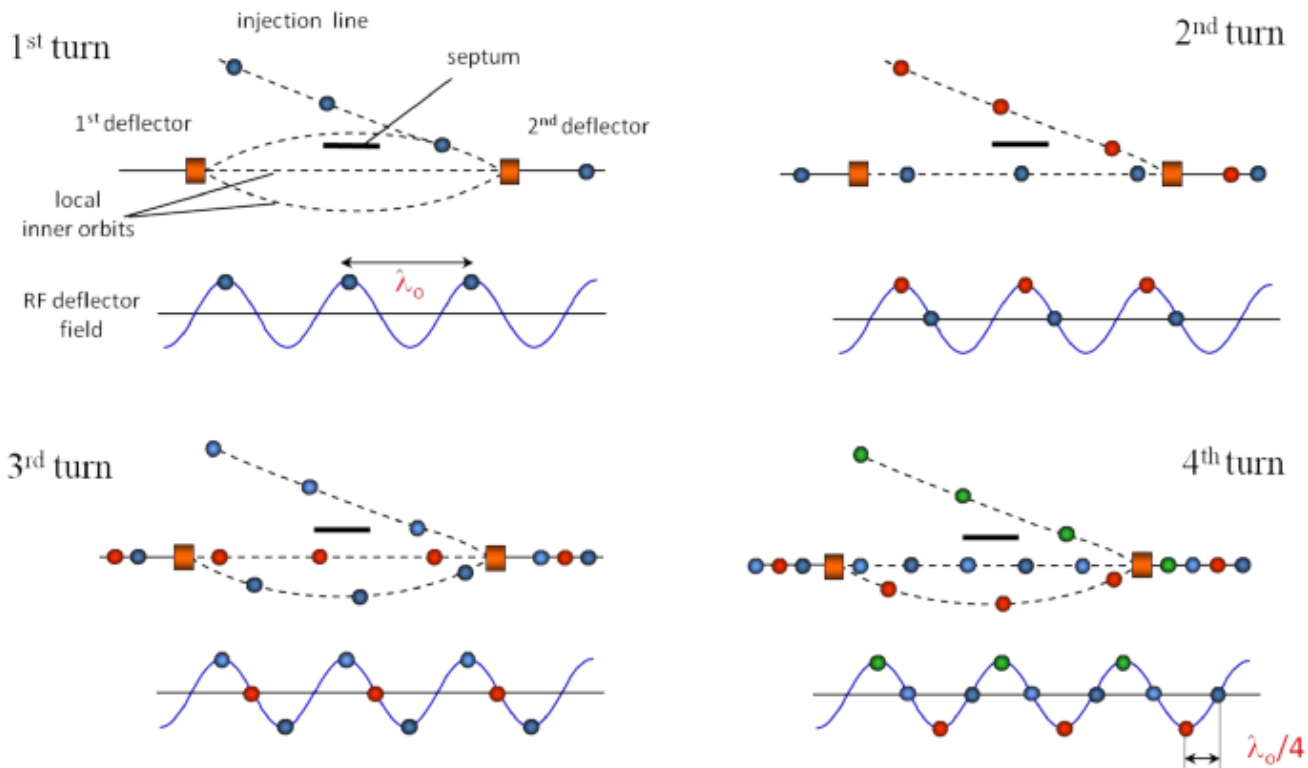

CR2 injection scheme (new lattice)

- Since turn 3 has an offset, the sextupoles act as quadrupoles (and sextupoles, and dipoles)
- The septum was moved to inject after the sextupoles

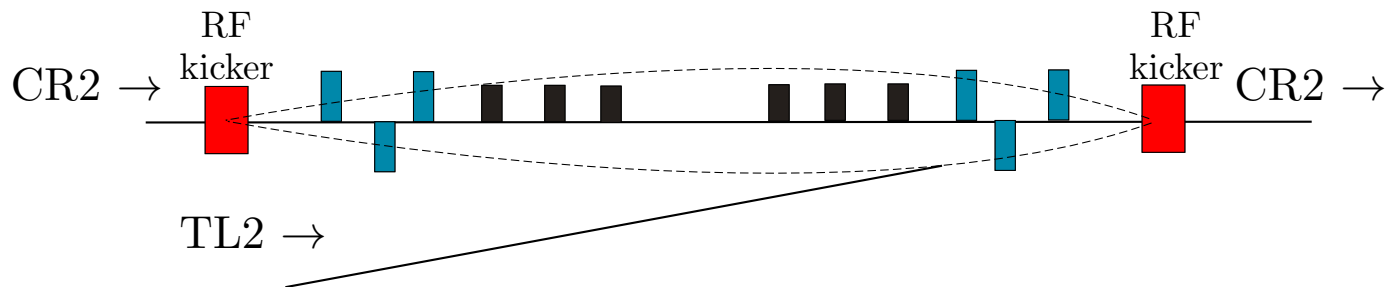

- With this design, we managed to obtain $\varepsilon_x = 151\mu\text{m}$, $\varepsilon_y = 147\mu\text{m}$ during 4 bunch recombination

Projected emittance growth:

sector	$\varepsilon_x [\mu\text{m}]$	$\Delta\varepsilon_x [\%]$	$\varepsilon_y [\mu\text{m}]$	$\Delta\varepsilon_y [\%]$
Dogleg	98.2	0.16	100	2.4
DL	120	22	107	6.7
CR1	141	18	122	14
CR2	151	8*	147	20*

Notes:

- CR2 results show only 4 bunch recombination
- If we use average emittances, CR2 optimization achieves $\varepsilon_x = 148\mu\text{m}$, $\varepsilon_y = 147\mu\text{m}$

Conclusions

- DBRC Placet2 lattices are ready for simulations and studies
- Several features (BPMs, dispersion-free readings, etc) have been added or updated in Placet2
- Lattice geometry updated (DL, CR1, TL2 and CR2)
- Projected emittance is a better optimization target
- There is a strong T_{566} aberration
- Sextupoles in dispersive regions can fix T_{566}
- CR2 injection design has been updated
- Preliminary results at CR2 are approaching design budget:
 $\varepsilon_x = 151\mu\text{m}$ $\varepsilon_y = 147\mu\text{m}$ projected over 4 bunch recombination

Next Steps:

- Optimization of CR2 for projected emittance and T_{566}
- Tracking of full recombined train to the end of TTA
- Re-optimization of DL and CR1
- Global Machine optimization
- Revisit the DL design (implement short path and update long)
- Implement more realistic septa at the joints
- Check magnet strength and longitudinal phase error tolerances
- Implement misalignments and beam-based alignment

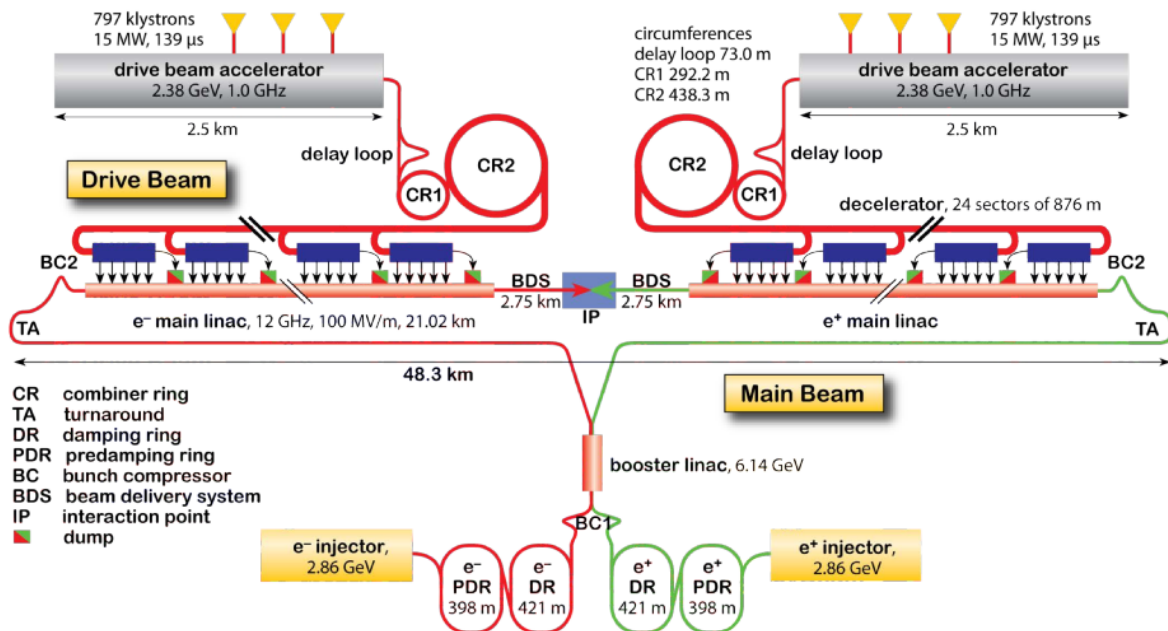

Thank you