

# Cryogenic Distribution Box for Fermi National Accelerator Laboratory

M. R. Svehla, E.C. Bonnema, E.K. Cunningham, Meyer Tool & Mfg., Inc. Oak Lawn, IL, USA

## ABSTRACT

Meyer Tool & Mfg., Inc (Meyer Tool) of Oak Lawn, Illinois is manufacturing a cryogenic distribution box for Fermi National Accelerator Laboratory (FNAL). The distribution box will be used for the Muon-to-electron conversion (Mu2e) experiment. The box includes twenty-seven cryogenic valves, two heat exchangers, a thermal shield, and an internal nitrogen separator vessel, all contained within a six-foot diameter ASME coded vacuum vessel. This paper discusses the design and manufacturing processes that were implemented to meet the unique fabrication requirements of this distribution box. Design and manufacturing features discussed include: 1) Thermal strap design and fabrication, 2) Evolution of piping connections to heat exchangers, 3) Nitrogen phase separator design, 4) ASME code design of vacuum vessel, and 5) Cryogenic valve installation.

## Introduction

Meyer Tool & Mfg., Inc (Meyer Tool) of Oak Lawn, Illinois is designing and manufacturing a cryogenic distribution box for Fermi National Accelerator Laboratory (FNAL). The distribution box will be used for the Muon-to-electron conversion (Mu2e) experiment. The box includes twenty-seven cryogenic valves, two heat exchangers, a thermal shield, and an internal nitrogen separator vessel, all contained within a six-foot diameter ASME coded vacuum vessel. This paper discusses the design and manufacturing processes that were implemented to meet the unique fabrication requirements of this distribution box.

## Thermal strap design and fabrication

The cryogenic distribution box contains piping at both liquid nitrogen temperature and liquid helium temperature, to reduce the heat load into the liquid helium the distribution box contains an 80K aluminum thermal shield. To reduce the heat load from the bayonets, helium relief valves, control valves, and warm pipes, thermal straps are used to thermally connect the components to the thermal shield.

A common thermal strap design utilizes copper braided cable. This method was considered for the distribution box but found not to suit the application. The thermal straps were required to accommodate relatively high heat loads, requiring large cross sectional areas, short distances between component and shield that would result in stiff/non-flexible assemblies due to both the cross-sectional areas and wicking of solder into braid, and economic considerations as multiple designs would be required for the varying components, their locations, and heat loads. A modular method was developed utilizing 0.4 mm thick x 63.5 mm wide C110 copper strips. The modular method of changing the number of strips utilized allowed for adjustment based on the cross-sectional area required. The design uses common end blocks, eliminates wicking issues, and as the straps are dead soft, provides good flexibility for both installation and decoupling of any loads caused by thermal movements. The modular straps are shown in figure 1.

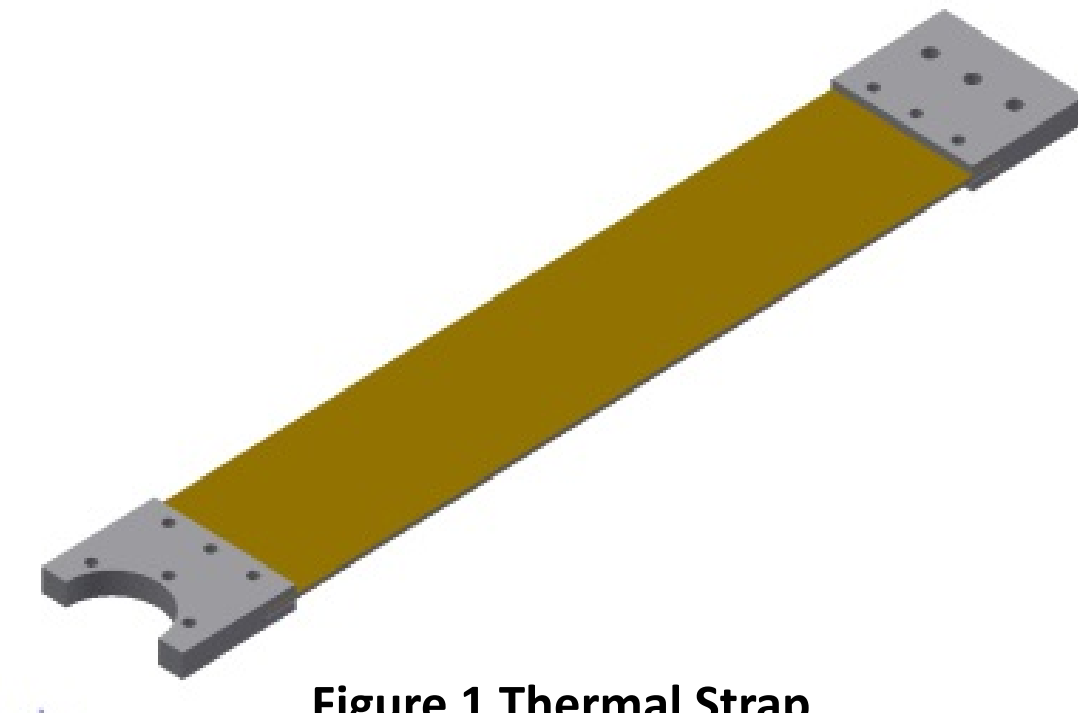

Figure 1 Thermal Strap.

## Evolution of piping connections to heat exchangers

The cryogenic distribution box contains two heat exchangers supplied by FNAL, a nitrogen to helium (N2-He HX) and helium to helium heat exchanger (He-He HX). Initially both heat exchangers were planned to mount end to end running the length of the distribution box, under the thermal shield, with inlet and outlet connections on the top of the vessel. During detailed reviews two problems were identified with this arrangement. First, the heat exchangers were used solely during cool down, and were idle the majority of the time. Due to the limited space in the distribution box, the piping connections had to run thru the heat shield and would add an unacceptable heat load on the system during operation. Second, the nitrogen to helium heat exchanger was determined to have a higher performance when mounted vertically as opposed to horizontally.

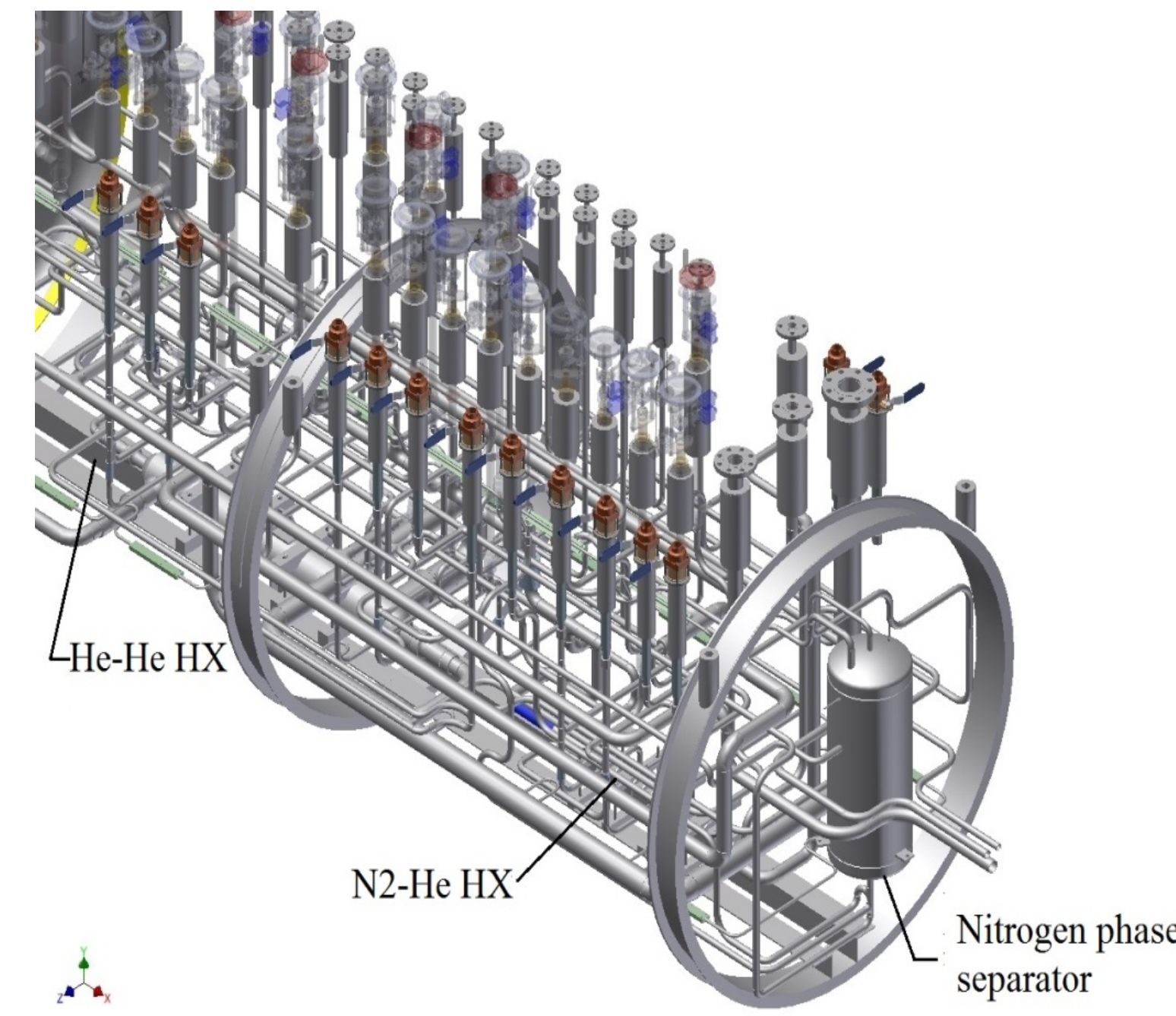

Figure 2 Original heat exchanger mounting and piping.

The solution developed was to move the nitrogen to helium heat exchanger outside the shield and to mount it vertically adjacent to the vacuum vessel head. The two connections to the N2-He heat exchanger were routed to the right vacuum vessel head, moving the piping completely outside of the thermal shield. This arrangement eliminated the heat load caused by the warm piping during normal operation modes. The two arrangements are shown in figures 2 and 3.

The two He-He heat exchanger connections that exit the distribution box were also routed to the right vacuum vessel head, moving the piping completely outside of the thermal shield. This left several warm pipes connected to the He-He heat exchanger inside the thermal shield. This piping could not be moved outside the shield, as it is connected to components inside the shield. The solution devised was to increase the number of MLI layers on the warm piping from 15 to 60 inside the shield and add thermal strapping immediately outside the shield.

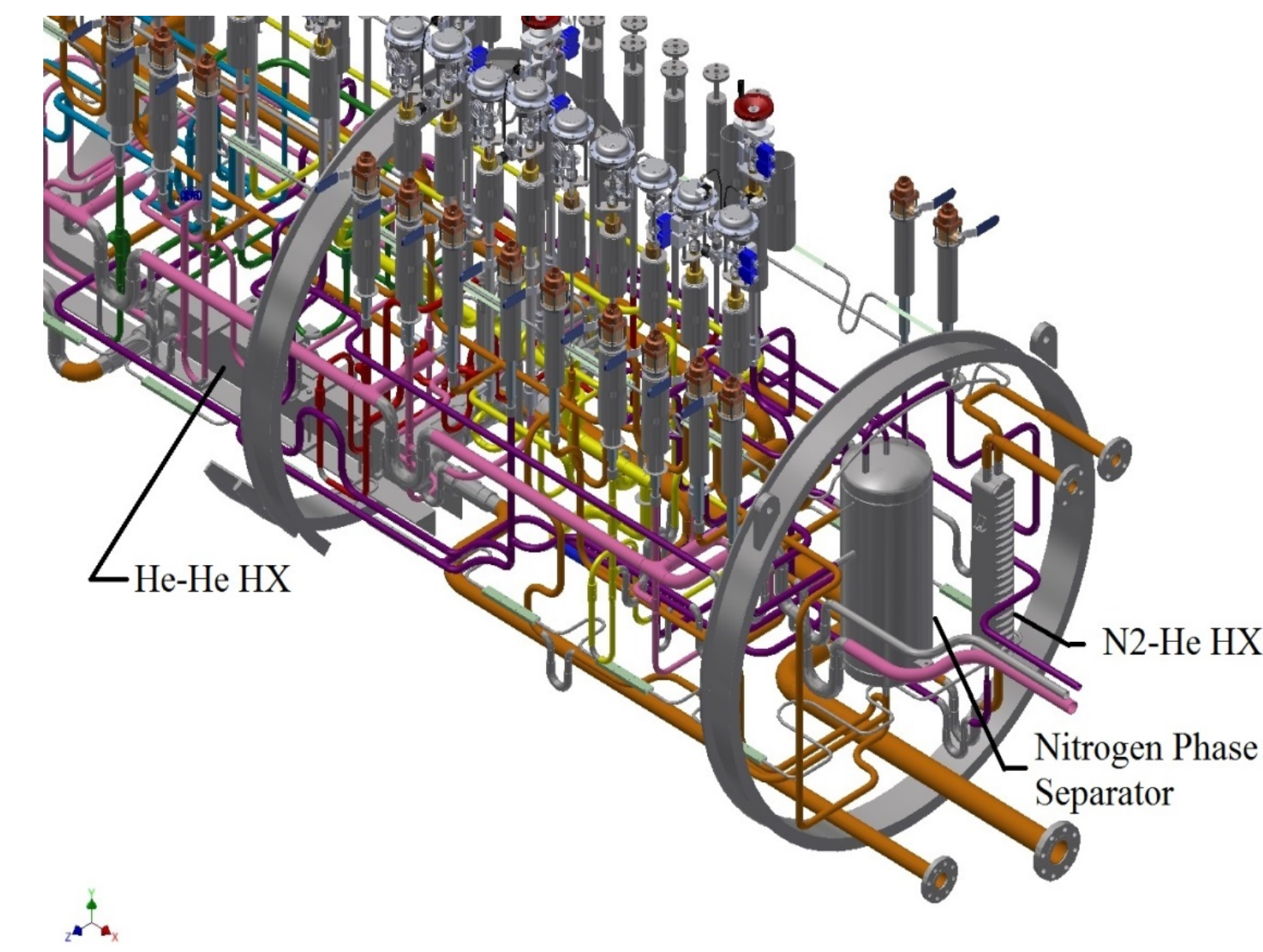

Figure 3 Final heat exchanger mounting and piping.

## Nitrogen phase separator design

The distribution box contains an ASME Code Stamped pressure vessel for separation of gaseous nitrogen from liquid nitrogen. The separator is rated at 1137.6 kPa (165 psig) @ 322K (120°F) with a MDMT of 77.6K (-320°F), and it is constructed from 300 mm (12") 304SS SCH 10S pipe with ASME F&D heads at both ends. Code calculations were done in Intergraph PV Elite allowing complete analysis of all vessel components and nozzles. Design was straight forward to meet ASME Code with the exception of the internal mist pad for separation, figure 4 depicts the internal mist pad.

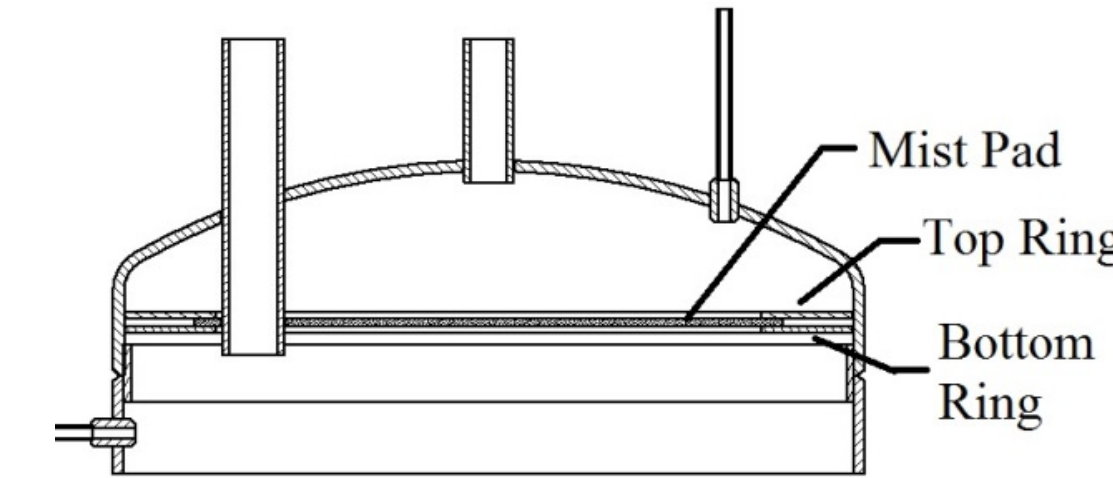

Figure 4 Nitrogen phase separator with mist pad.

The technical specification set design parameters of 60 grams per second of saturated nitrogen at a maximum pressure drop of 0.69 kPa (0.1 psi). Mott Corporation porous metal sheet was initially selected for the internal mist pad, calculations were completed using formula and data from Mott Corporation in addition to obtaining viscosity of saturated nitrogen from the NIST website. Multiple media grades were calculated, with media grade 20 being selected to meet the design criteria, figure 5 depicts the calculation of the pressure drop using an Excel table.

Media Grade 20		
z	4.7	Per data sheet
zfm	7.56	ft <sup>3</sup> calculated on ideal gas law, from 60 grams/sec
area	0.486	ft <sup>2</sup> area open
flux	15.5556	acfm/ft <sup>2</sup>
visc	0.0064	cP From NIST chart
thickness	0.125	in selected
pressure drop	0.058489	Specification .1 PSI

Figure 5 Excel calculation of pressure drop.

A fabrication challenge was encountered with the internal mist pad due to limits of the Mott sheet size availability. The sheets are only available to a maximum size of 254 mm (10 in) x 610 mm (24 in). The available width was too small to allow cutting a single pad to fill the entire cross section of the pipe. Welding pieces together was considered, however the final solution selected was to install a 234 mm (9.2 in) ID x 312 mm (12.3 in) OD top and bottom ring around the Mott pad. The ID of the ring was smaller than the ID of the pipe, this avoided welding the Mott pad and still provided sufficient area for the pad for the specified maximum pressure drop.

## ASME code design of vacuum vessel

The design specifications were set at full internal vacuum and 103.4 kPa (15 psig) internal pressure @ 310.9K (100°F) with a 244.3K (-20°F) MDMT, built and stamped per the ASME Pressure Vessel Code. Operation for a distribution box vacuum vessel typically requires a vacuum only rating, however, Fermilab engineers wanted to ensure an additional level of safety, and added the ASME Code requirement. The ASME requirement added additional complexity due to the seventy three (73) nozzles in the vacuum vessel shell. The nozzles were spaced to meet Code requirements, re-enforcement requirements, and meet Code weld sizes. All these requirements more restrictive than for a vacuum only design. The Code calculations were done in Intergraph PV Elite which allowed calculations for the shell, heads and nozzles. Due to the number of nozzles, symmetry was applied in PV Elite based on nozzle spacing and size to reduce the number of nozzles required to be modelled. Twenty-five (25) out of the seventy three (73) nozzles were modelled, reducing the amount of modelling required without impacting the accuracy of the calculations; figure 6 depicts the PV Elite model of nozzles in the shell.

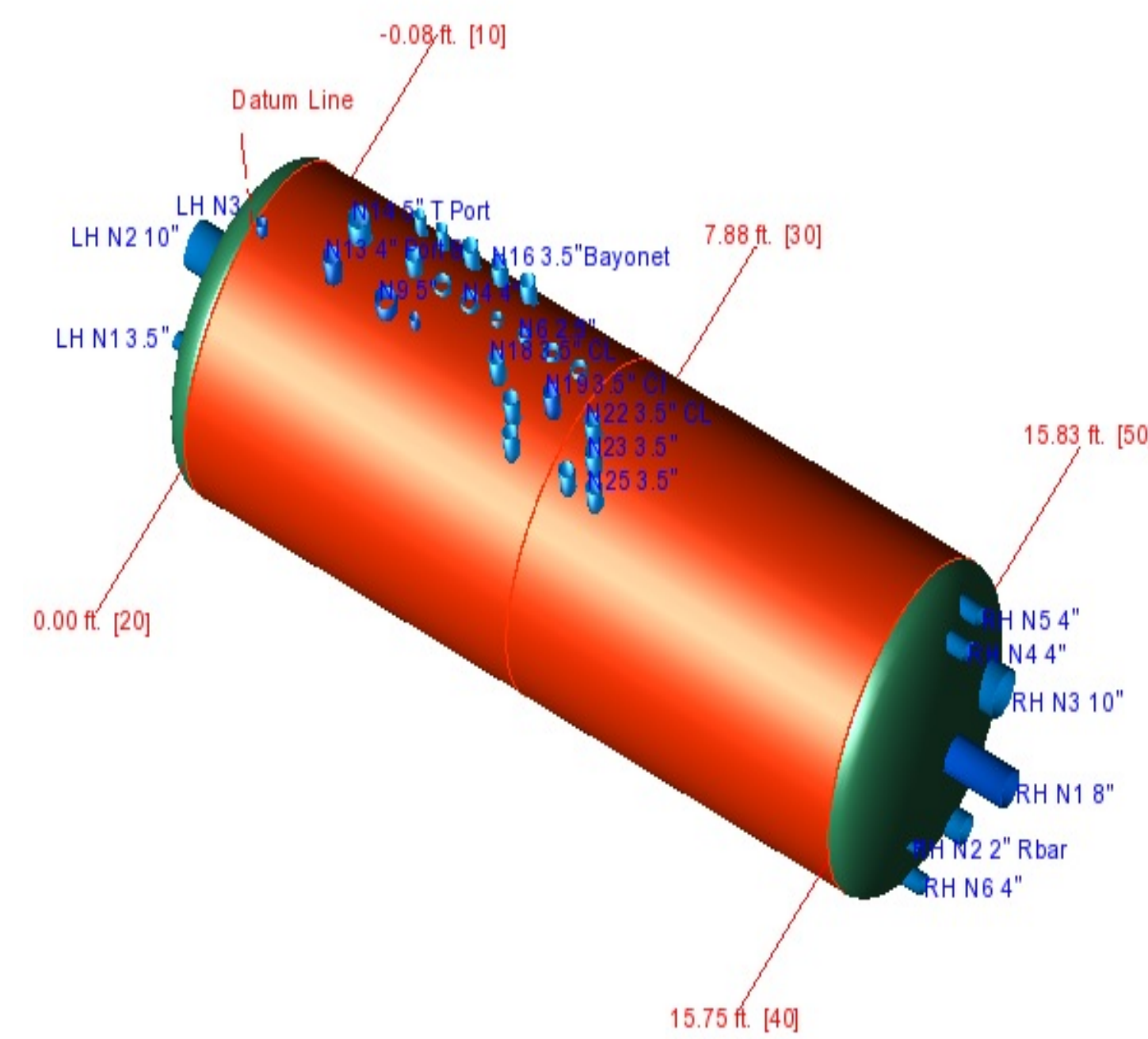

Figure 6 Model of vacuum vessel with reduced number of nozzles in shell.

The technical specification required limitations on the physical envelope available to accommodate the distribution box in the existing building space. The distribution box is limited in height, width and length to a 2.6 m x 1.82 m x 5.49 m (102 in x 72 in x 216 in) envelope. Ideally we would have liked to utilize an U shaped insert to hold all the valves, bayonets, etc. to which a cylindrical shell would be fit after completion of internal assembly. However, the strict envelope restrictions and the large number of penetrations resulted in a 1.82 m (72 in) diameter vacuum vessel x 5.49 m (216 in) long, head to head. A construction method was devised to attach the two top shells to each other, leaving the bottom halves off to allow access for installation and test of valves and piping prior to closure of the vacuum vessel envelope. This construction method is illustrated in figure 7.

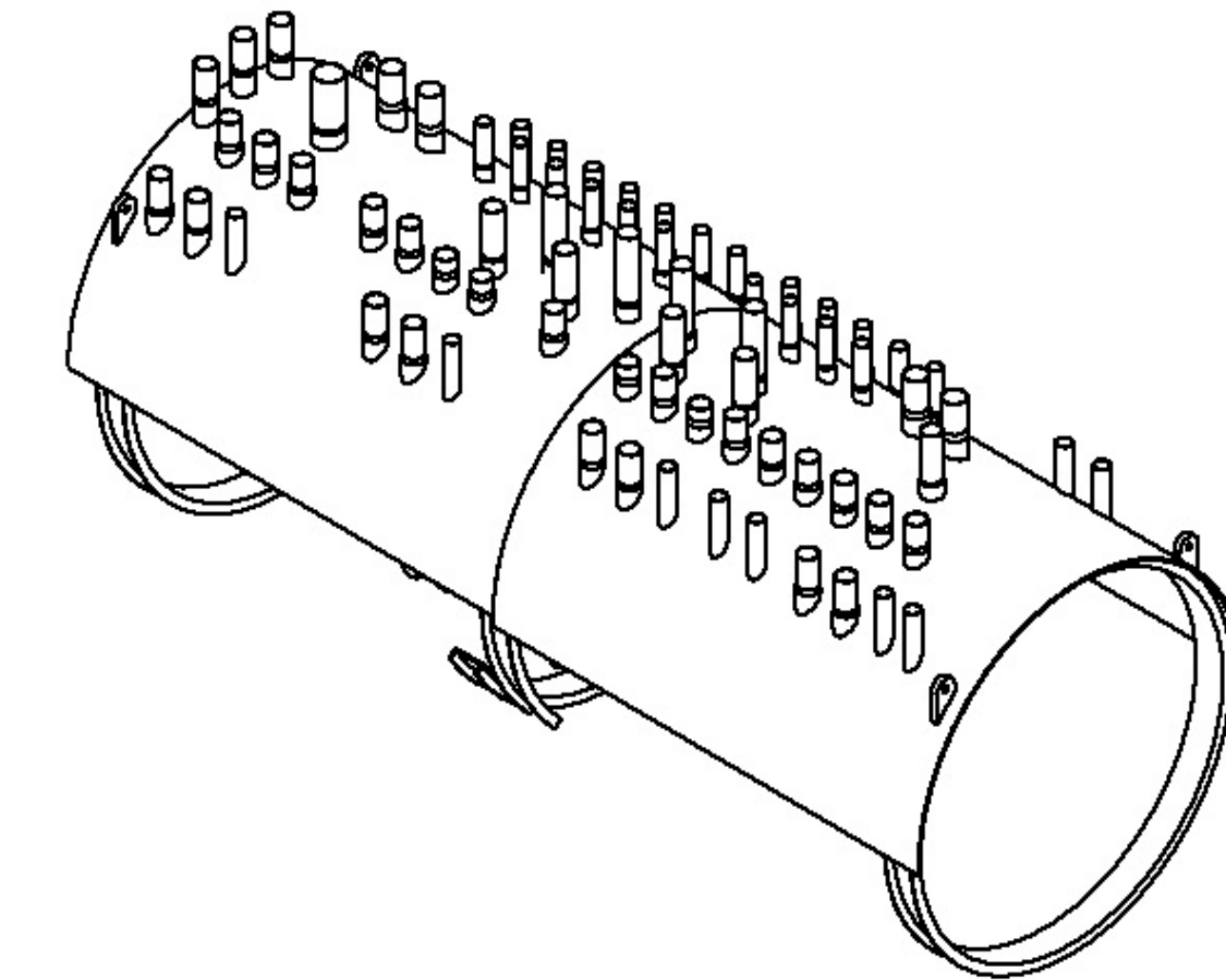

Figure 7. Construction method.

## Cryogenic valve installation

The Cryogenic valves required by the technical specification were WEKA AG valves. The valves consist of eight (8) valves with pneumatic open / close actuators, thirteen (13) valves with Siemens PID controllers, and six (6) valves with manual hand operators. Valve sizes include: three (3) DN15 valves, twenty (20) DN20 valves and one (1) DN50 valve.

A technical challenge due to the number of valves and the limited space on top of the distribution box was encountered. The solution developed was to have the Siemens controllers moved off the valves, this allowed for just enough space to install the valves. In addition, actuators have to be rotated relative to valve bodies to clear adjacent valve actuators. The ability of the WEKA AG valves to allow for infinite rotation of the actuator relative to the valve body allowed for this solution to be implemented.

## Summary Conclusion

The distribution box currently under fabrication for Fermilab requires both standard fabrication techniques used in cold box construction, application of the ASME Pressure Vessel Code rules, and specialized techniques suited for the unique spacing requirements of this application. In order to meet the unique challenges of this distribution box, Meyer Tool developed custom modular heat transfer straps, utilized 3D modelling techniques to address both internal and external spacing limitations and the technical requirements, employed knowledge of the ASME Code to meet the pressure vessel code requirements while accommodating the construction requirements of a complex cryogenic distribution box; balancing these conflicting requirements to meet the requirements of Fermilab's technical specification. Figure 8 depicts the final design of the distribution box, showing the twenty-seven cryogenic valves in addition to all nozzles in both the shell and right head.

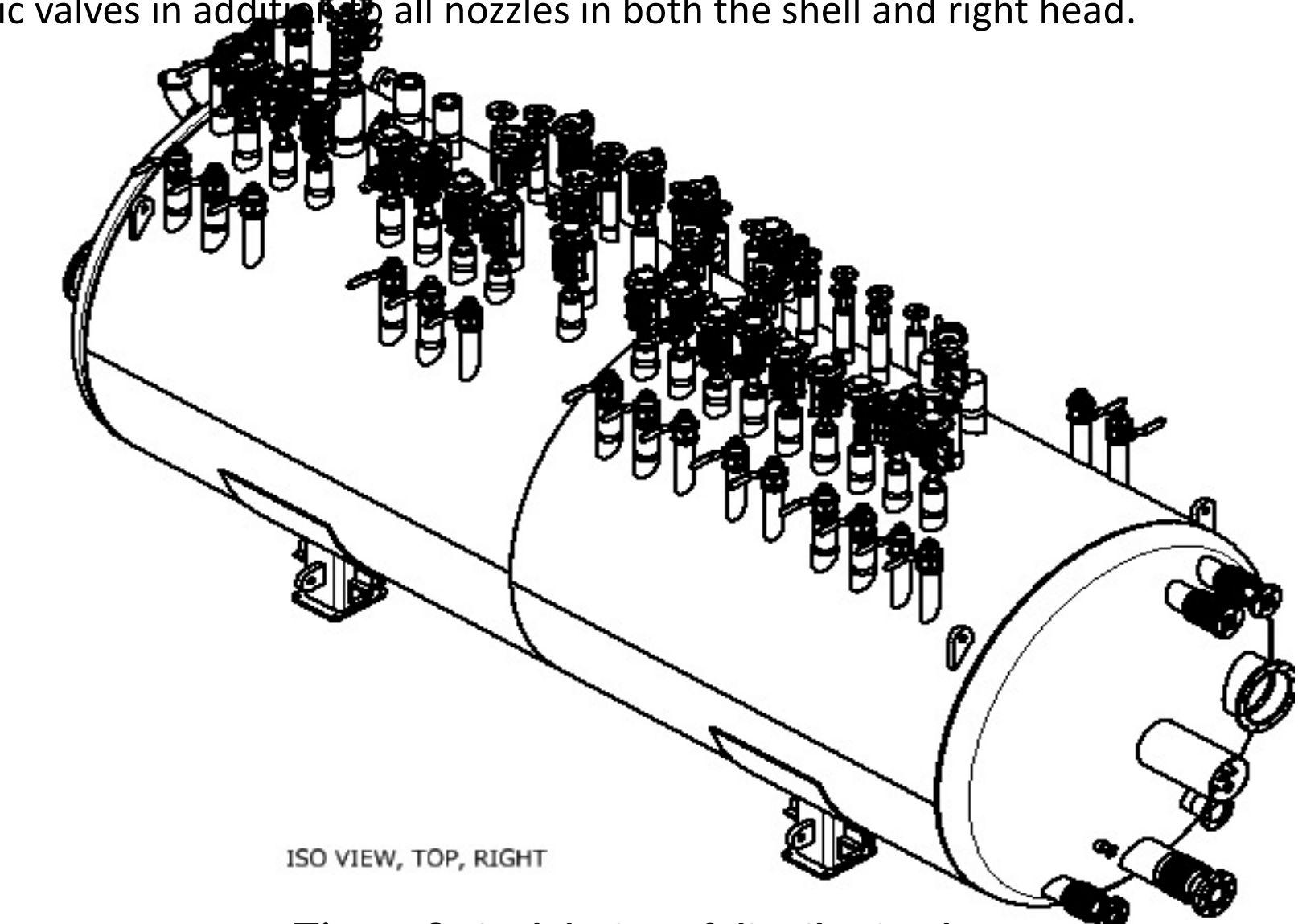

Figure 8 Final design of distribution box.

# MEYER

Meyer Tool & Mfg., Inc.

# SPECIALISTS IN CRYOGENIC, VACUUM & PRESSURE TECHNOLOGIES

