

Construction and Testing of Large GEM Trackers for Super BigBite Spectrometer at JLAB

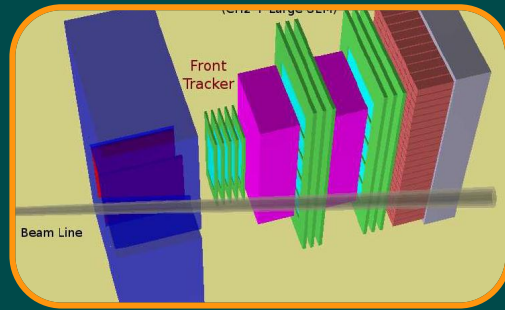

Huong Nguyen
University of Virginia
(On the behalf of the SBS collaboration)

- **GEM Back Trackers for Super BigBite Spectrometer (SBS)**
- **Quality Control and Fabricating Procedures of GEM Module for SBS Back Trackers**
- **Characterization of SBS Back Tracker GEM Module**

- SBS program enables measurements of elastic form factor of nucleons
 - GE(n)/GM(n) and GM(n)
 - GE(p)/GM(p)
- Requirement for SBS tracking system
 - Large tracking area
 - High rate: ~ 500 kHz/cm²
 - Spatial resolution < 100 μ m
 - Low mass to reduce multiple scattering
- Front GEM Tracker
 - Equipped with six 2D tracking layers
 - Each layer has active area of 40x150 cm²
 - Each layer consists of three GEM modules
- Back GEM Trackers
 - Equipped with ten 2D tracking layers
 - Each layer has active area of 60x200 cm²
 - Each layer consists of four GEM modules

SBS in use as a Proton Polarimeter

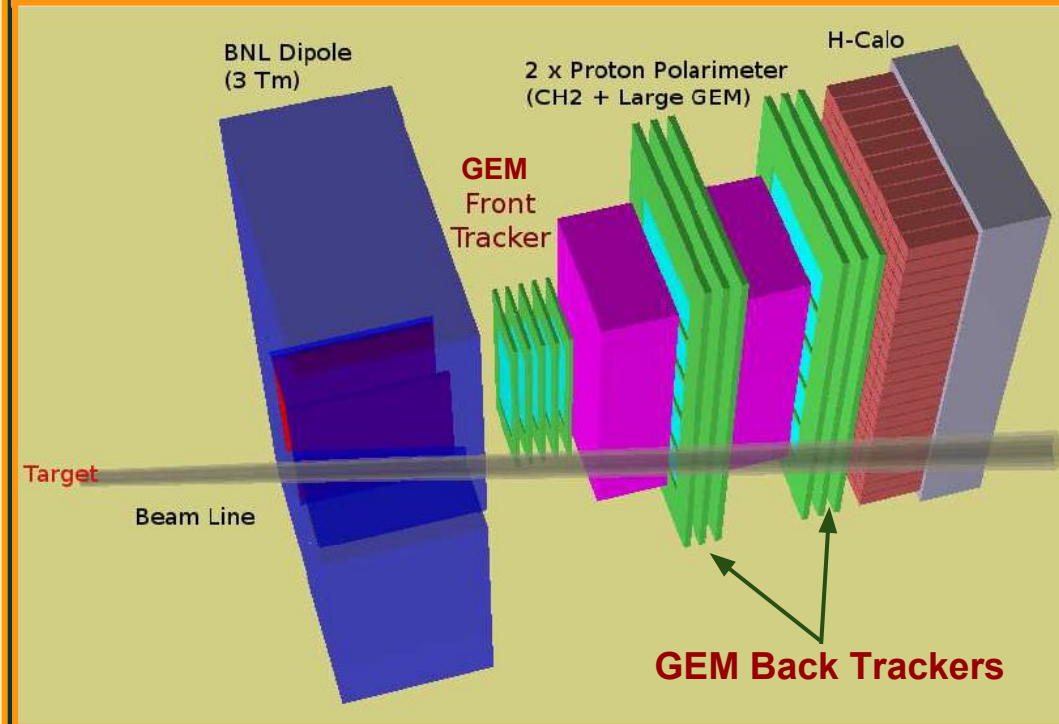

- Design and fabricate SBS trackers
 - Front Tracker (FT) : INFN-Roma & INFN-Catania
 - Back Trackers (BT): UVa Group

Large GEM Module for SBS Back Trackers

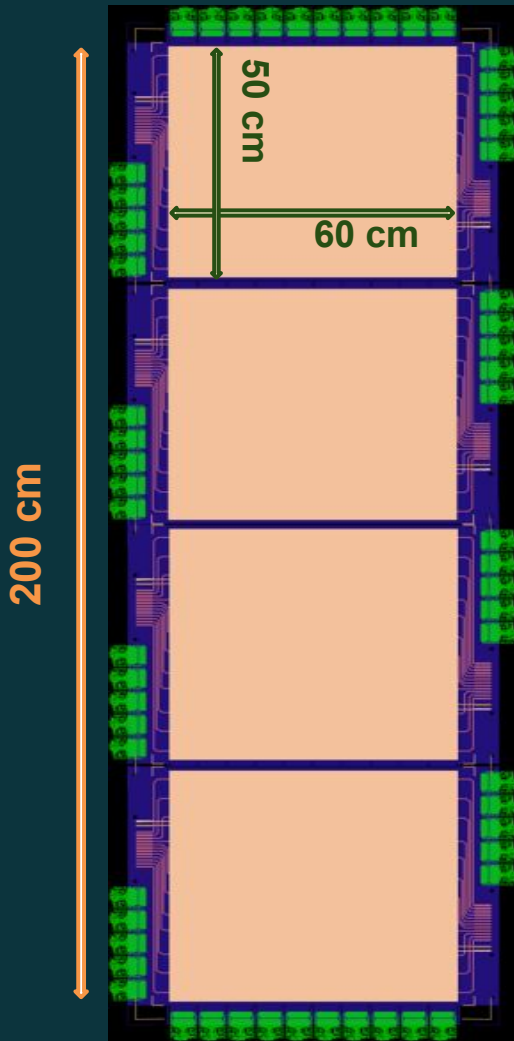

Back Tracker Layer

- Large size of GEM module for SBS back trackers
 - One layer of SBS back trackers (BT) consist of 4 GEM modules; each GEM module has active area of $60 \times 50 \text{ cm}^2$
- Configuration of SBS BT GEM module
 - Based on COMPASS triple-GEM detector
 - Has three GEM layers for electron application
 - Amplified charges are collected by 2D Cartesian readout board
 - Gaps in drift, transfer and collection regions 3:2:2:2 (mm)

COMPASS Triple-GEM Configuration

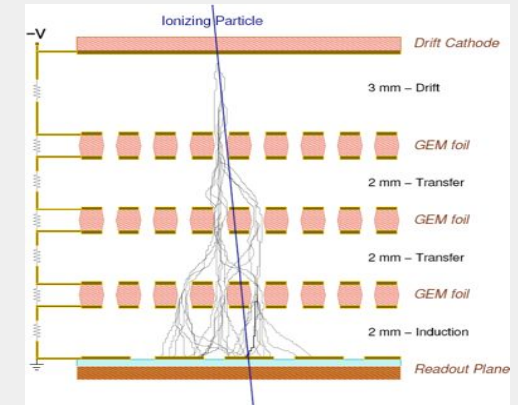

COMPASS 2D Readout Board

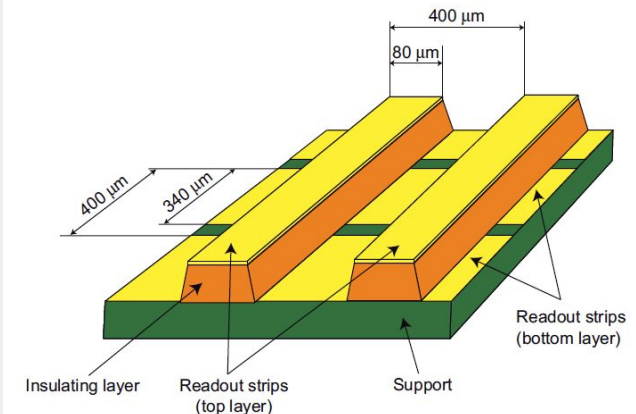

Design of SBS Back Tracker GEM Module

Design is optimized for:

- Large active area of 60x50 cm²
- Operating at a high background rate (up to 1 MHz/cm²)
- Spatial resolution of 70μm
- Compromising low mass requirement and rigidity of the GEM chamber

Cross Section of SBS BT GEM Module

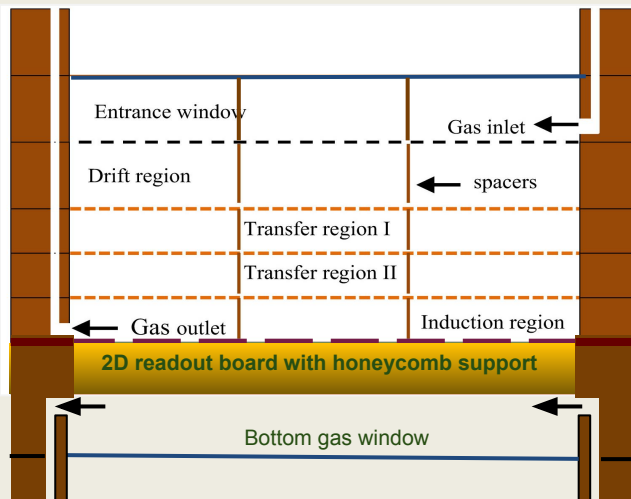

Components of SBS BT Module

- Components produced at CERN
 - GEM foils
 - ReadOut board
 - Honeycomb board
- Components produced by Resarm
 - Made of Permaglass
 - 2mm thick frames to maintain distance between two adjacent layers of GEM foils & RO board
 - 3mm thick frames to maintain distance between drift cathode and adjacent layers
- Components produced at UVa
 - Aluminized gas window foils
 - Support frames for gas-window
 - PCB boards for HV supply
 - Gas connectors

SBS BT GEM Module Exploded View

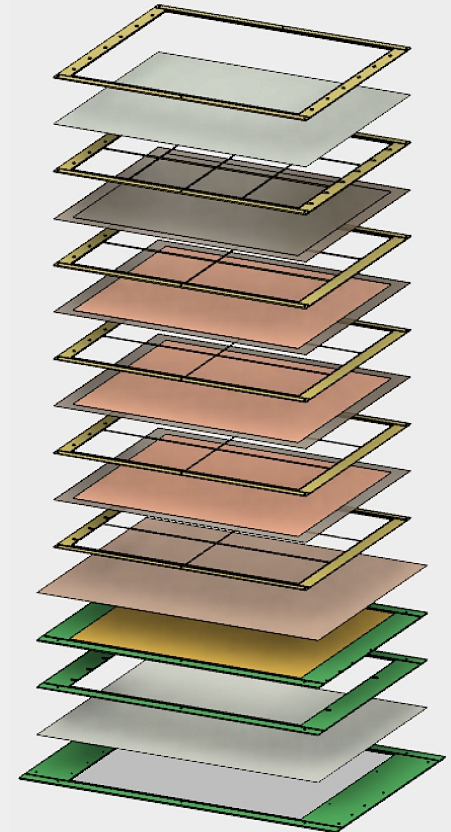

Quality Control for SBS BT GEM Foils

SBS BT GEM Foil

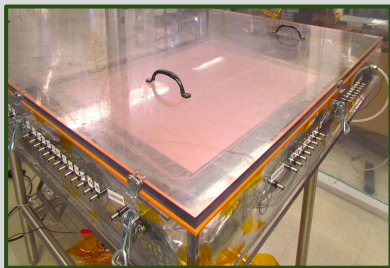
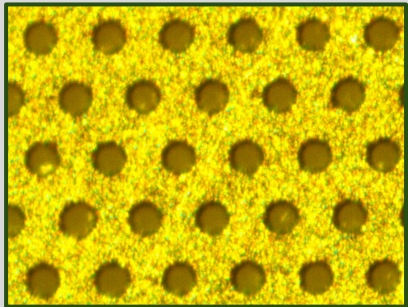
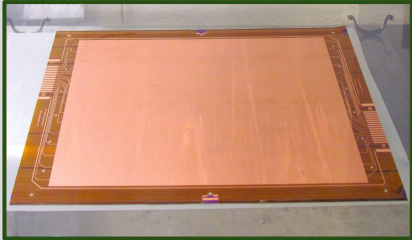

- Design parameters of SBS BT GEM foils
 - 50 μ m kapton foil coated with 5 μ m copper
 - 70 μ m diameter holes at 140 μ m pitch
 - Active area of 60x50 cm²
 - Top side divided in 30 sectors
- Inspection of GEM foils
 - Sampling optical inspection
 - Measure the dimensions of the holes
 - Evaluate the shape of the holes
 - Leak current measurement of each sector:
Applied HV=550V across foil in N₂ gas environment.
Accepted foil has leak current < 5nA
- Common issues with GEM foils
 - Imperfect hole shape and size: 7/150
 - High leak current: 10/150
 - Positive spikes in leak current spectrum: 6/150
- High acceptance rate (90%)

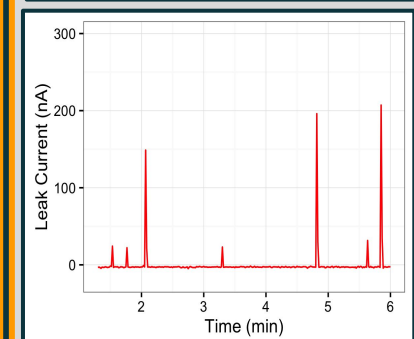
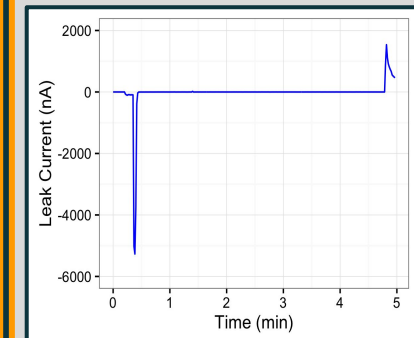
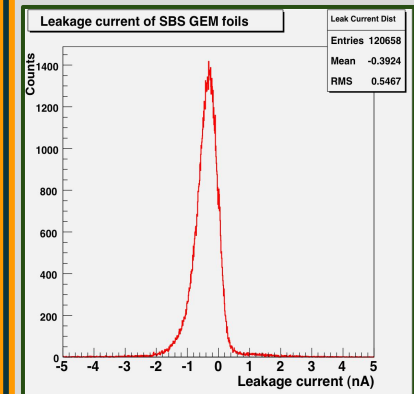

Quality Control for Readout Board

- Design parameters of RO board

- 2D perpendicular top & bottom strips; width of 80 μm & 350 μm at 400 μm pitch
- 50 μm thick Kapton layer separating top & bottom strips
- Active area of 60x50 cm^2

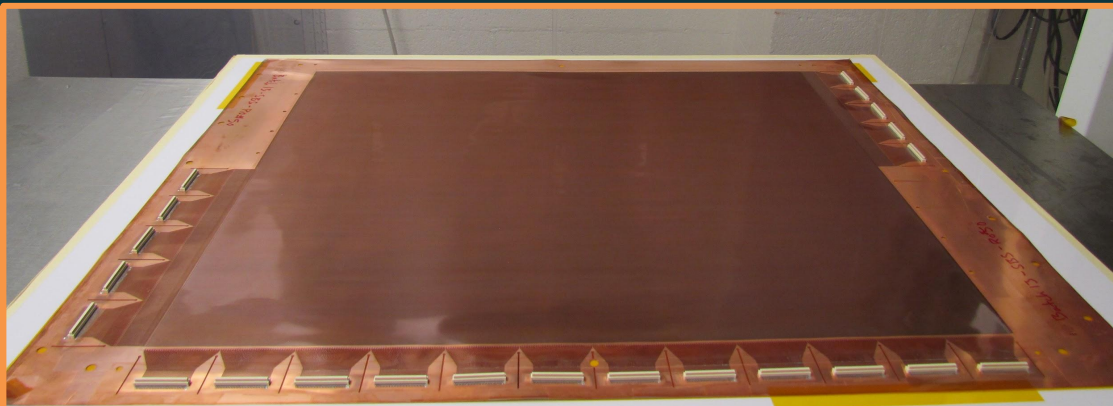

- Optical inspection of the RO board

- Identify locations of broken strips
- Measure dimensions of the strips
- Evaluate the spread of the base of the Kapton layer

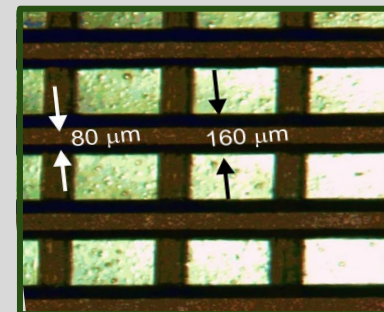
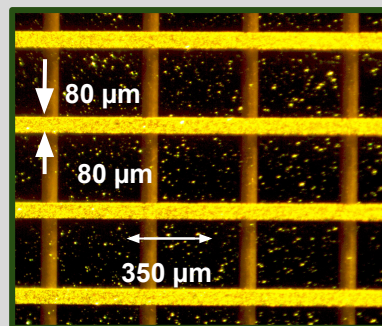

- Quality of CERN Readout boards

- Most common issue: large spread of the base of the Kapton layer masks part of the bottom strips
- Acceptance rate (95%)

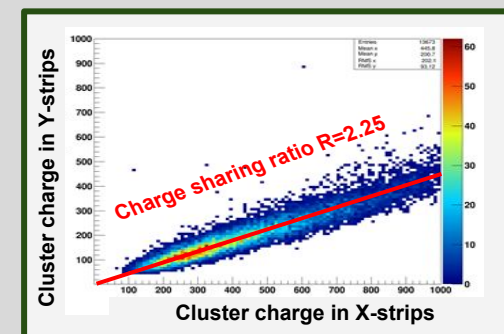
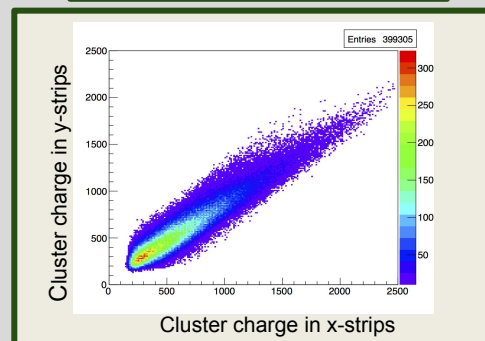

Preparation of Support Frames

- **Design parameters for support frames**

- Maintain uniform gap between adjacent layers of GEM module
- Made of fiberglass with thickness of 2 mm and 3 mm
- Attached spacers of 300 μm width in active area
- Inner area 60x50 cm^2 ; longer side of the frame is narrow (8mm)
- 3 mm diameter holes on the wider side of frame for gas circulation

- **Procedures of frame preparation**

- Polished with sandpaper to remove sharp fiber ends on the spacers and inner edges of the frame
- Cleaned in ultrasonic bath with demineralized water for 15 mins
- Hung in cleanroom to dry (3 days)
- Coated spacers and inner edges exposed to the active area with a thin layer of polyurethane (Nuvovern LW+Hardener)
- Hung in cleanroom to dry (1 day)

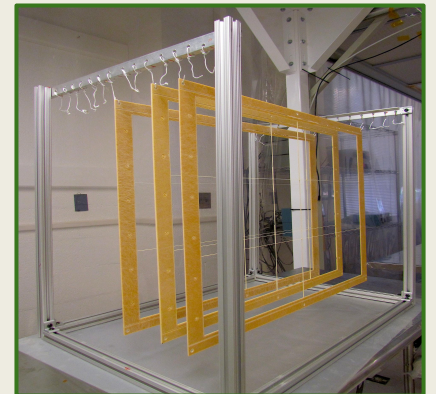
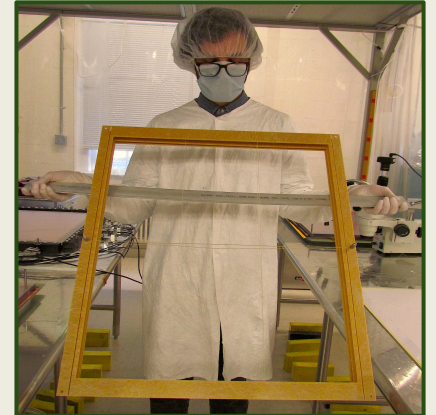
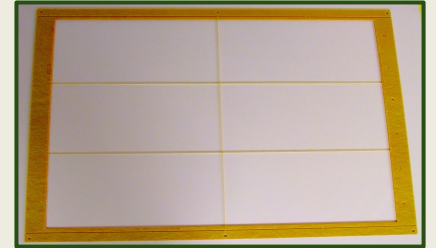

Construction Activities in Cleanroom

9

- Assemble the bottom gas-window layer and readout layer
 - Glue bottom gas-window layer to the support frame
 - Glue RO board on honeycomb (HC)
 - Glue RO+HC layer on top of bottom gas-window layer
- Stretch and Assemble GEM layers
 - Apply sufficient tension (5 N/cm) along the GEM (drift) foil to insure uniform gap and avoid deformation of GEM hole structure
 - Glue the frame on top of stretched foil (foil and frame are polymerized in a day)
 - Validate framed GEM foil with leak current test
 - Glue 3 GEM layers in sequence on top of RO+HC layer
- Assemble cathode layer and top gas-window layer
 - Use similar stretching/glueing process as for GEM foils
 - Glue cathode layer and top gas-window layer respectively on top of the 3rd GEM layer
- Mount gas tubes and gas connectors to the module

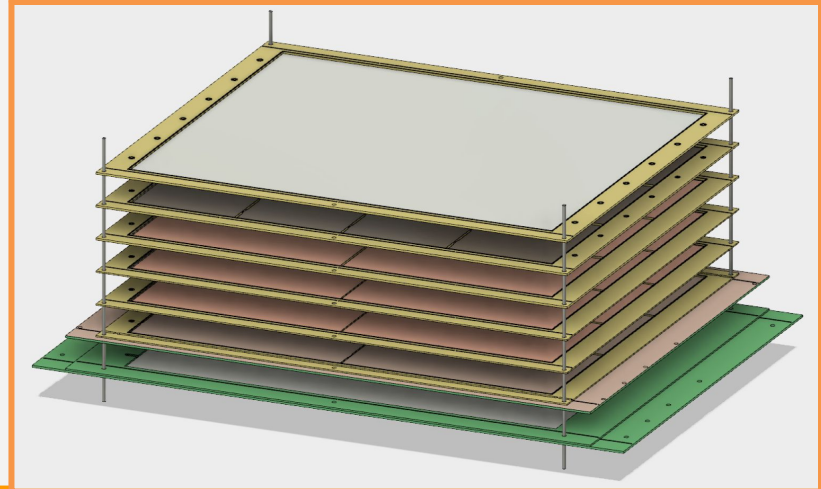
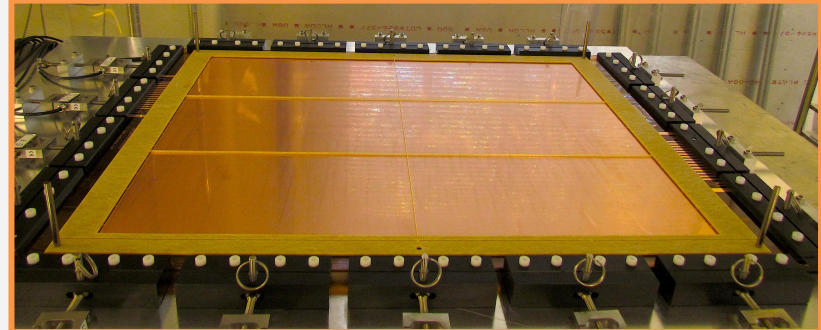
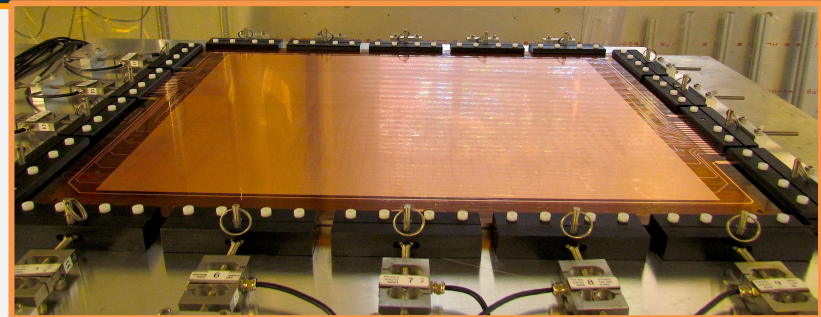

Final Constructions Outside Cleanroom

10

- Seal 4 sides of GEM module with a thin layer of Dow Corning Coating to prevent gas leak
- Flow N_2 gas into GEM module for 3 days to remove residual dust
- Perform the final leak-current test for each sector
- Electrical Connection
 - Each sector of the 1st and 2nd (3rd) GEM foils is connected to HV distribution board through individual $10\text{ M}\Omega$ ($1\text{M}\Omega$) protection resistor
 - Mount the HV divider on GEM module to distribute voltage across 6 GEM electrodes, drift cathode and top gas window
- High Voltage Certification
 - Monitor GEM module with applied HV=4200V with N_2 gas flowing for 3 days
 - Monitor GEM module with applied HV=4100V with Ar/CO_2 (70/30) gas flowing for 3 days
- GEM module is ready for final laboratory testing

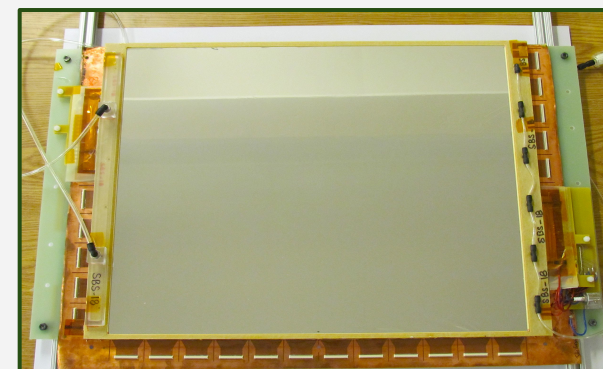
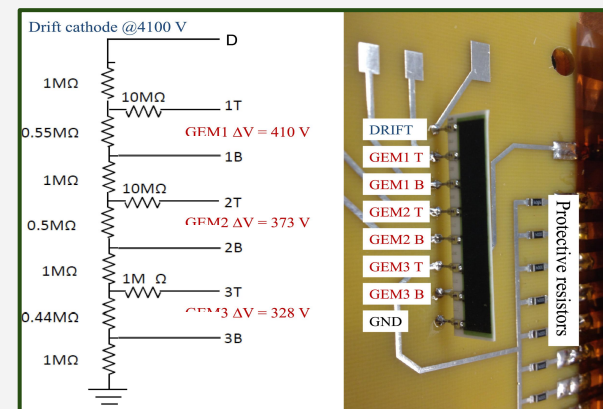
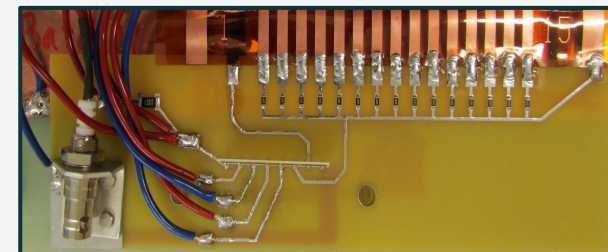

- **Laboratory testing procedure**

- Continuously flowing Ar/CO₂ gas into the GEM module at a rate of 10 L/h (representing 3 module volume changes per hour)
- Operating GEM module at applied HV in the range of 3.9kV - 4.2 kV and taking cosmic data for two weeks
- Mounting GEM module in front of X-ray generator. Operating GEM module at applied HV 4000 V and taking data with radiation flux of 25 MHz/cm² at the surface of GEM module

- **Basic performance parameters of SBS BT GEM module**

- Gain uniformity: evaluating 2D distribution of cluster positions (gain variation less than 15%)
- Efficiency: scan efficiency in HV range of 3.8kV - 4.2kV and evaluate the efficiency plateau (95% at 4.1 kV)
- Charge sharing of 2D readout strips (charge sharing ratio of 1.0)

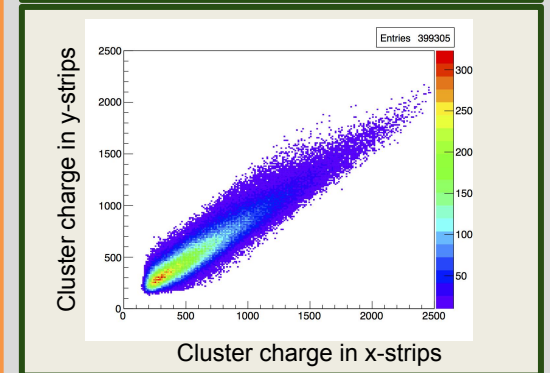
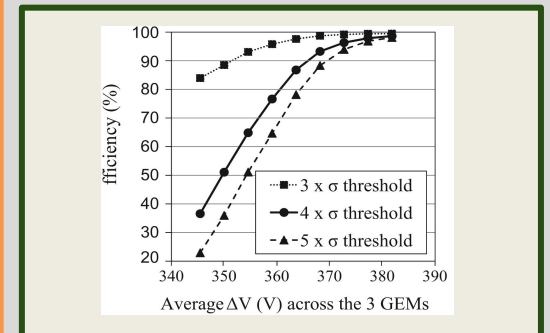
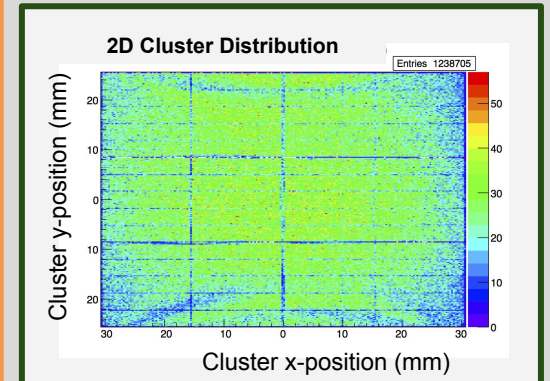

Solved Issues with SBS BT Module (1)

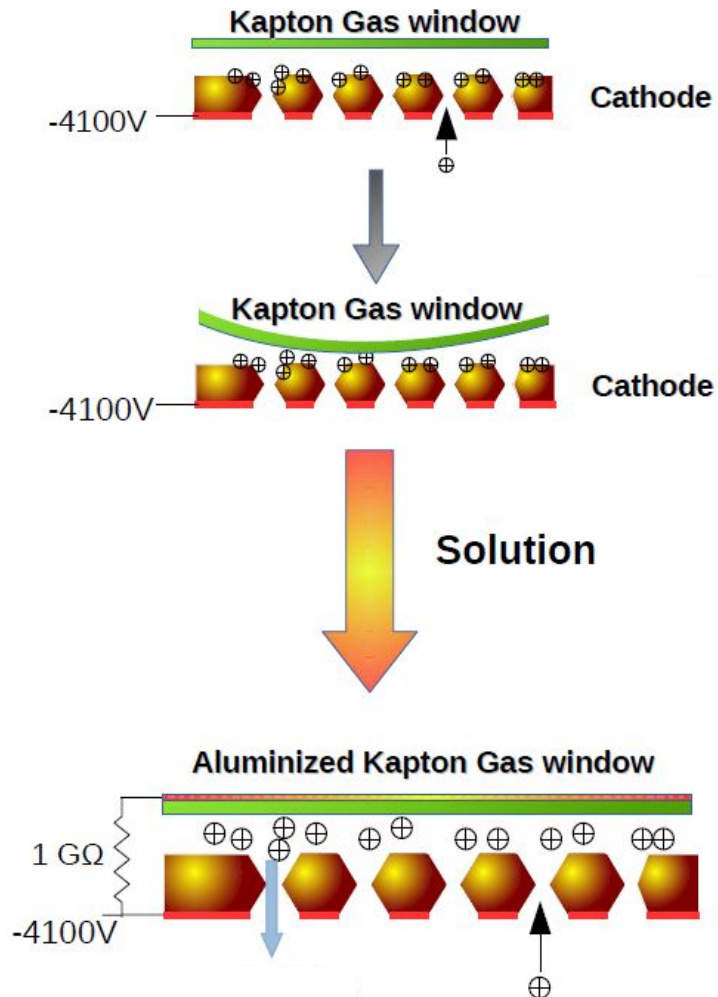

Problem No1: Collapsing of Kapton gas window on drift cathode

- Kapton gas windows were pulled down and attached to the drift cathode during operation of GEM module at applied HV=3900 V with X-ray irradiation flux $\sim 25 \text{ MHz/cm}^2$
- The collapse strongly affected time resolution and gain uniformity of the GEM module

Causes and Solution

- **Causes**
 - Kapton layer was charged up during operation of GEM module in high rate environment
 - Electrostatic force between gas window and drift cathode caused the collapse
- **Solution**
 - Use aluminized kapton gas window, and set it to the same voltage as the drift cathode to prevent charge accumulation on the gas window and the Kapton layer of the drift cathode

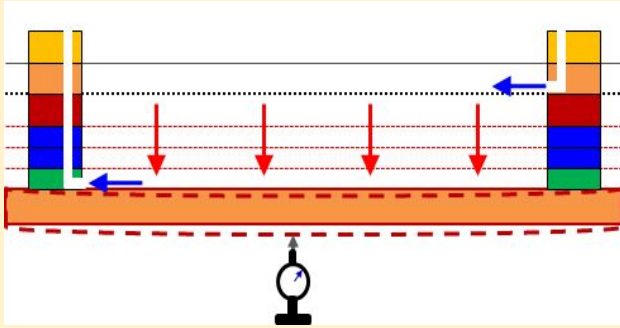

Solution

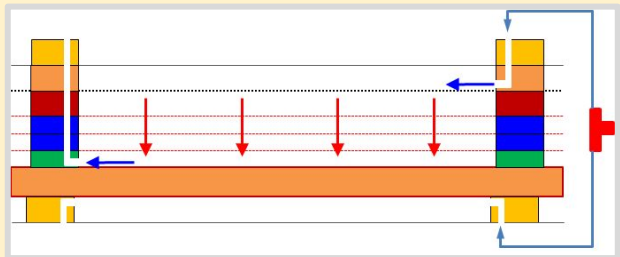

Problem: Deformation of the RO+Honeycomb layer

- The bending of the RO+HC layer depending on the gas flow rate inside the chamber
- Deformation of RO+HC layers strongly affects the signal peak position at high gas flowing rate (7.2 L/h)

Solution

- Modify the gas outlet to reduce the gas pressure inside the chamber
- Add a Kapton foil gas window at bottom of the chamber and flow the gas inside to compensate the overpressure inside the chamber

Mounting Frame

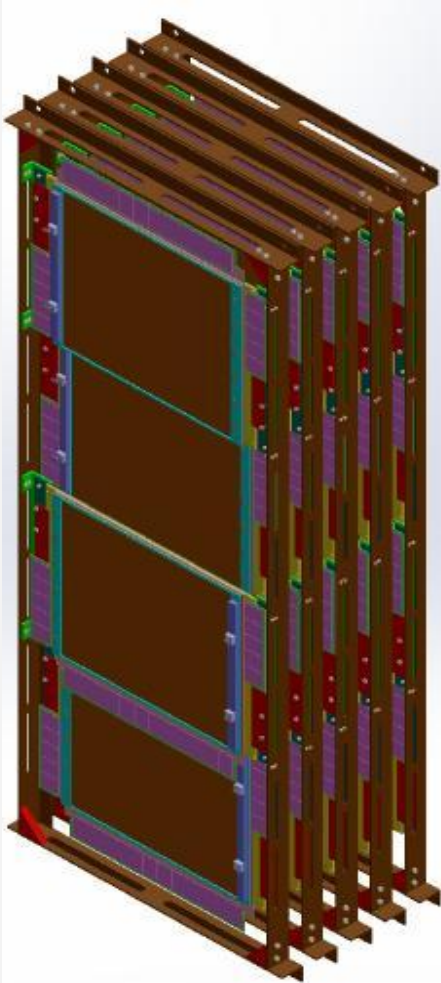

- **Forty-two GEM modules were built and tested**
 - **40 modules 100% operational**
 - **2 modules have one bad sector (97% of active area operational)**
- **Six spare GEM modules are expected to be completed by Aug 2017**
- **Set up a full chain of MPD electronic to readout 4 GEM modules**
- **Designed and tested mounting frame for SBS BT GEM layers**



- **In January 2017, we completed the DOE milestone of building 40 100% operational GEM modules for SBS**
- **Finishing up with production of 6 spare SBS BT GEM modules**
- **In process of transferring GEM modules to Jlab**
- **Finish installation and commissioning of SBS Back Trackers in two years**

Too much background!!!



BACK UP

Unequal Charge Sharing vs Particle Rate

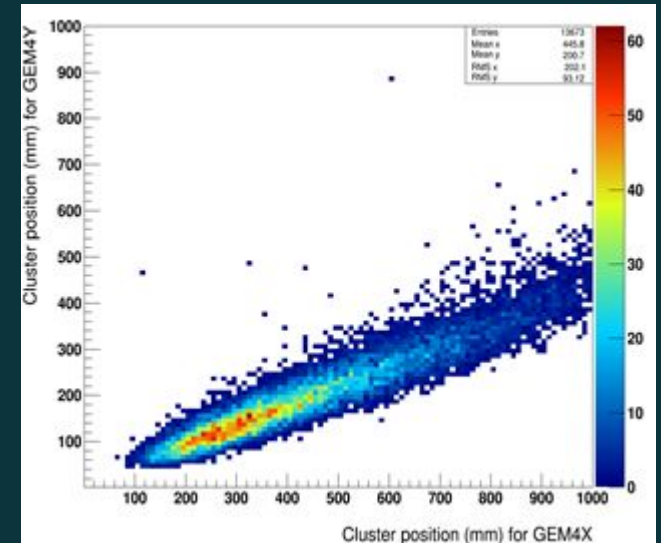
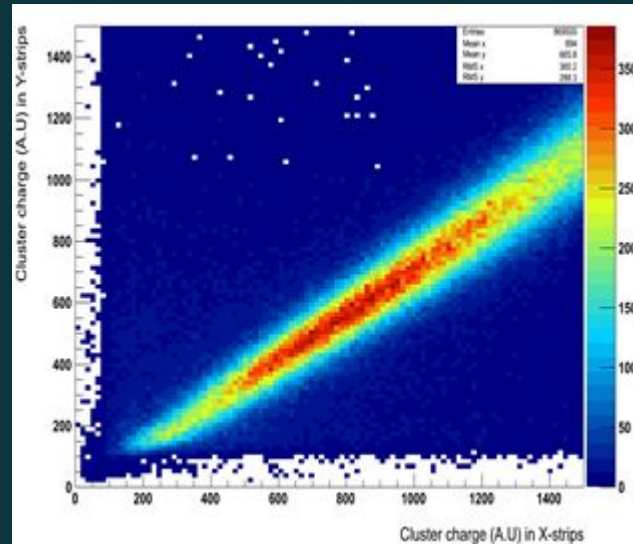
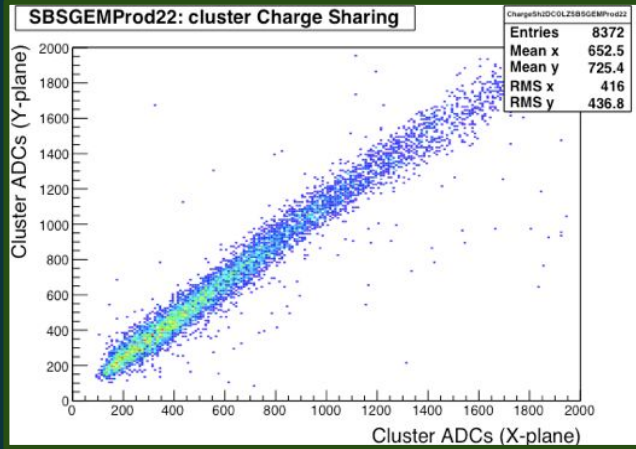

Bottom Side of Good vs Bad GEM Foil

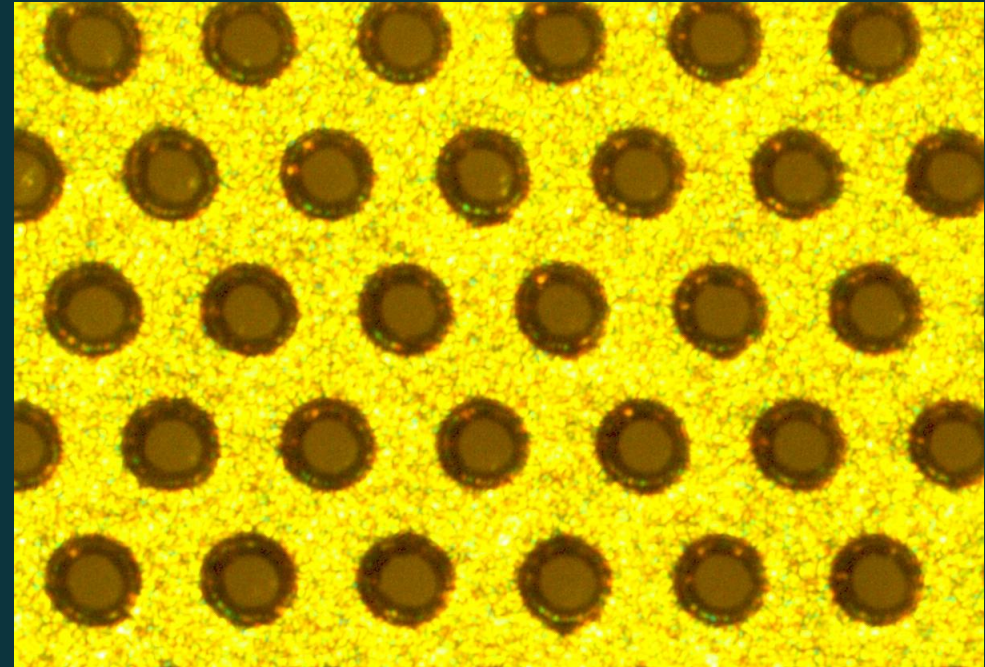
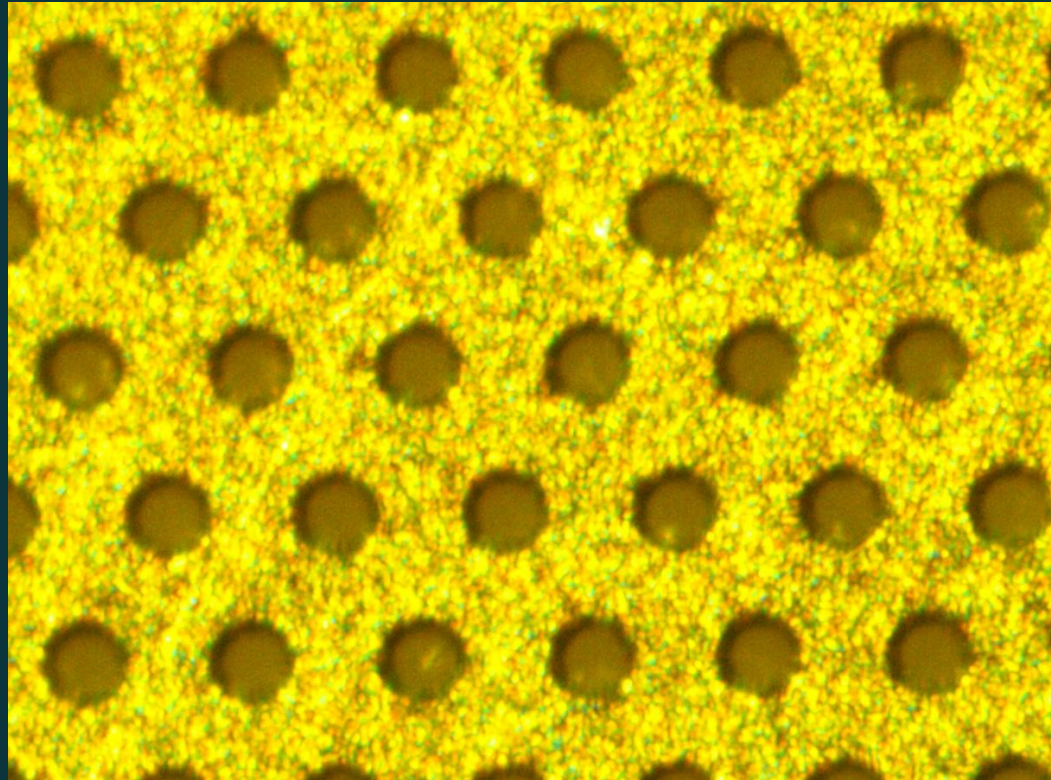

Quality Control for SBS BT GEM Foils

SBS BT GEM Foil

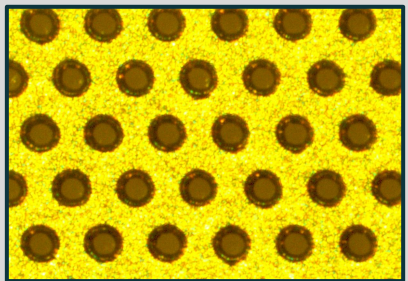
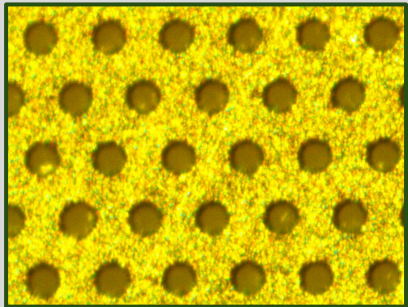
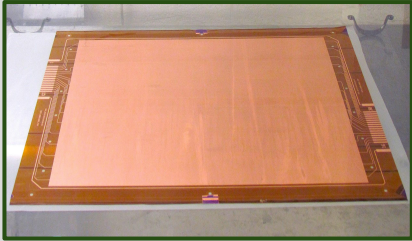

- **Design parameters of SBS BT GEM foils**
 - 50 μ m kapton foil coated with 5 μ m copper
 - 70 μ m diameter holes at 140 μ m pitch
 - Active area of 60x50 cm²
 - Top side divided in 30 sectors
- **Inspection of GEM foils**
 - Sampling optical inspection
 - Measure the dimensions of the holes
 - Evaluate the shape of the holes
 - Leak current measurement of each sector:
Applied HV=550V across foil in N₂ gas environment.
Accepted foil has leak current < 5nA
- **Common issues with GEM foils**
 - Imperfect hole shape and size: 7/150
 - High leak current: 10/150
 - Positive spikes in leak current spectrum: 6/150
- **High acceptance rate (90%)**

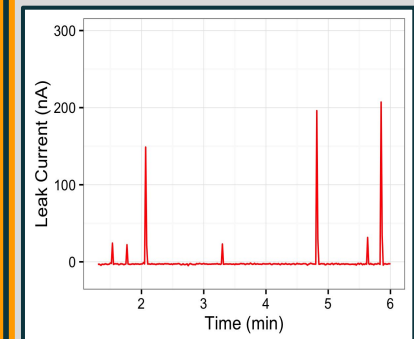
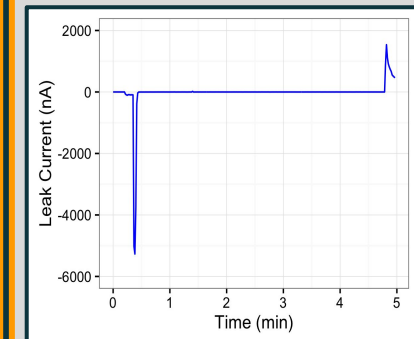
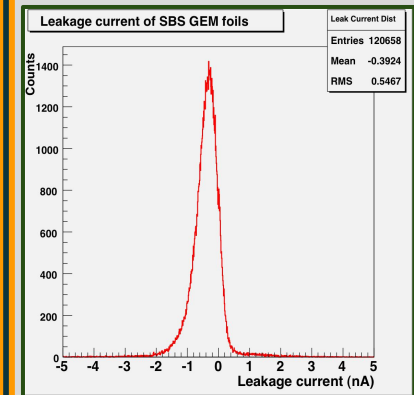

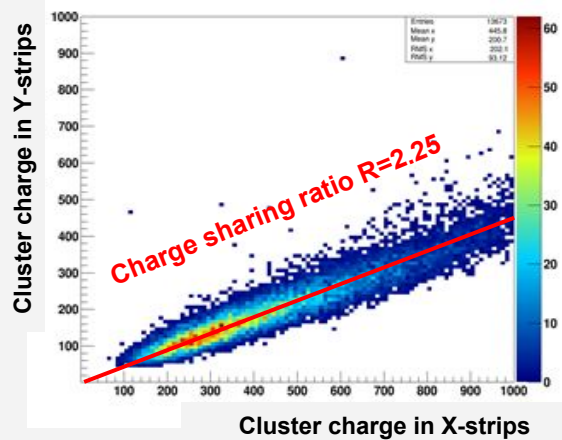

Problem 2: non-equal charge sharing of x-strip vs y-strips

- The width of top and bottom strips was designed to obtain almost equal charge sharing between x- and y- coordinates, charge sharing ratio expected to be $R \sim 1.0$)
- Largely unequal charge sharing observed at ratio $R=2.25$
- Charge sharing dependent on particle rate

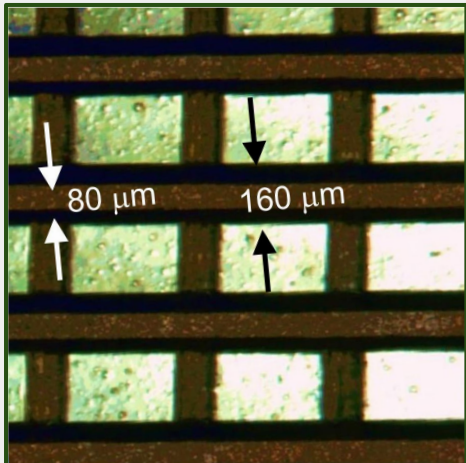

Causes and solution:

- Causes: Largely exceeding spread of the base of the Kapton
⇒ Reducing exposed area of bottom strips
⇒ Charging of Kapton layer increases shielding of bottom strips
- Solution:
 - Improvement of quality of readout board at CERN
 - Optical inspection of the board and use RO board with kapton spreading less than 10 μm

- **Laboratory testing procedure**

- Continuously flowing Ar/CO₂ gas into the GEM module at the rate of
- Operating GEM module at applied HV in the range of 3.9keV - 4.2 keV and taking cosmic data for two weeks
- Mounting GEM module in front of X-ray generator. Operating GEM module at applied HV 4000 V and taking data with radiation flux of 25 MHz/cm² at the surface of GEM module
- Analyze collected data to study performance of the GEM module

- **Basic performance parameters of SBS BT GEM module**

- Gain uniformity: evaluating 2D distribution of cluster positions (gain variation less than 15%)
- Efficiency: scan efficiency in HV range of 3.8kV - 4.2kV and evaluate the efficiency plateau (95% at 4.1 kV)
- Charge sharing of 2D readout strips (charge sharing ratio of 1.0)

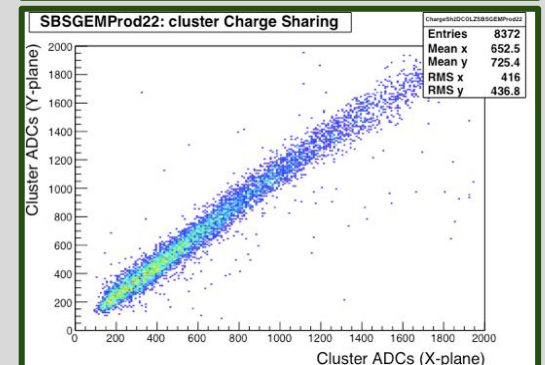
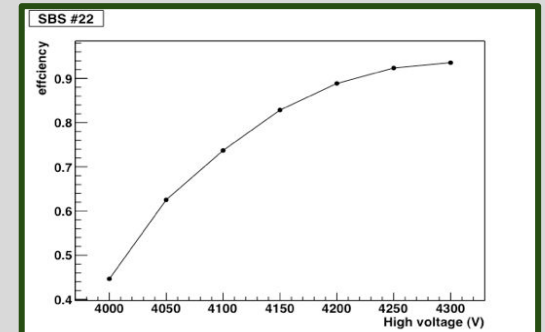
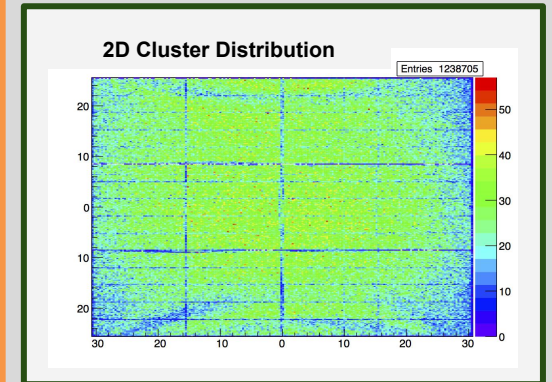

Quality Control for Readout Board

- **Design of RO board**

- 2D perpendicular top & bottom strips; width of 80 μm & 350 μm at 400 μm pitch
- 50 μm thick Kapton layer separating top & bottom strips
- Active area of 60x50 cm^2

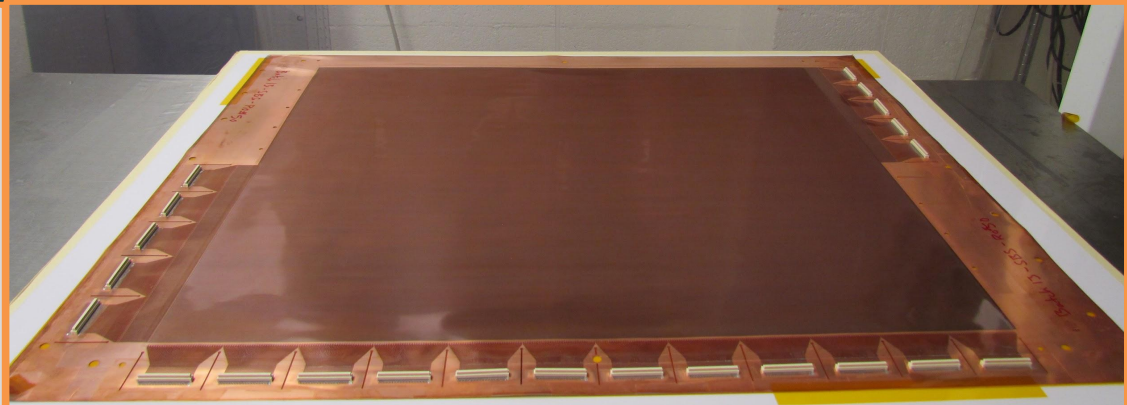

- **Optical inspection of the RO board**

- Identify locations of broken strips
- Measure dimensions for the strip
- Evaluate the spread of the base of the Kapton layer

- **Quality of CERN Readout boards**

- Most common issue: large spread of the base of the Kapton layer masking part of the bottom strips
- Acceptance rate (45/48)

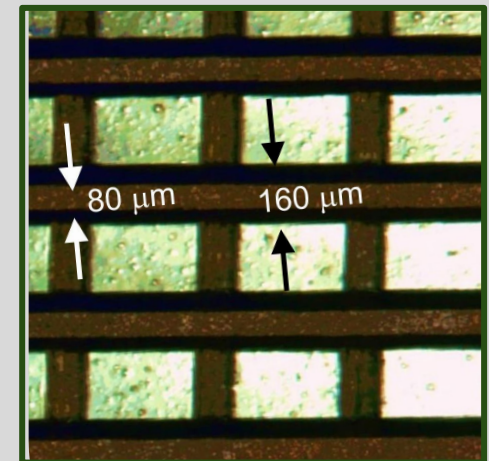
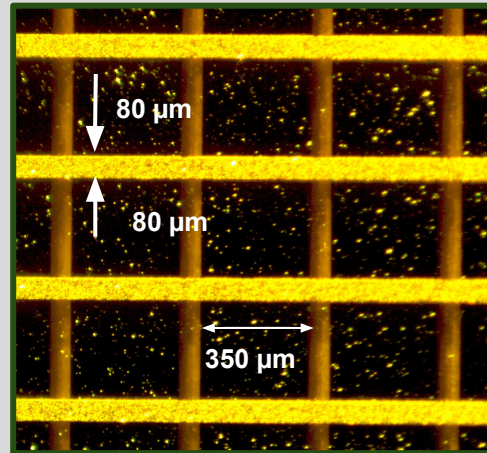

Production Status of SBS Back Trackers

