

ATLAS utilizes a two-level trigger system in Run-2 to reduce the bunch-crossing rate of 40 MHz to an average recording rate of about 1 kHz. Events are selected based on physics signatures such as presence of energetic leptons, photons, jets or large missing energy. Despite the limited time available for processing collision events, the trigger system is able to exploit topological information as well as multi-variate methods, for example for b-tagging or tau identification.

The ATLAS trigger menu specifies which triggers are used during data taking and how much rate a given trigger is allocated. For 2018 data taking, the trigger selections and menus have been improved to handle expected luminosities above $2 \times 10^{34} \text{ cm}^{-2}\text{s}^{-1}$ and to ensure robustness in the presence of multiple interactions per bunch crossing ("pileup").

ATLAS Run 2 Trigger and Data Acquisition

Trigger rates and bandwidth

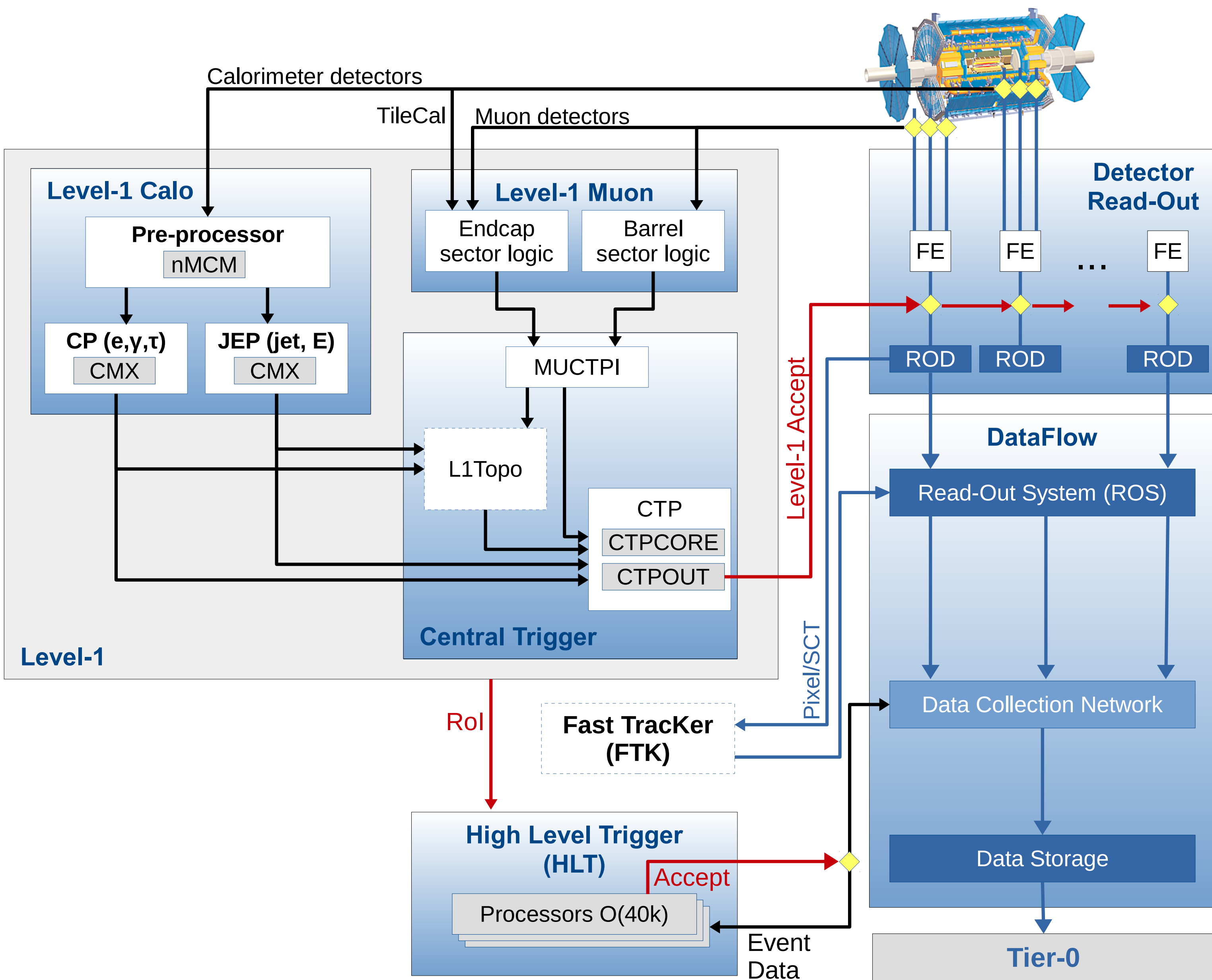

- **L1 menu** consists of 512 trigger items (single signatures and combinations)
 - E.g. MU15, 2EM12, 4J15
- Rates are controlled via prescale sets, computed for fixed values of the instantaneous luminosity
- As luminosity decreases prescale sets get activated at predefined points to maximize bandwidth given to different triggers

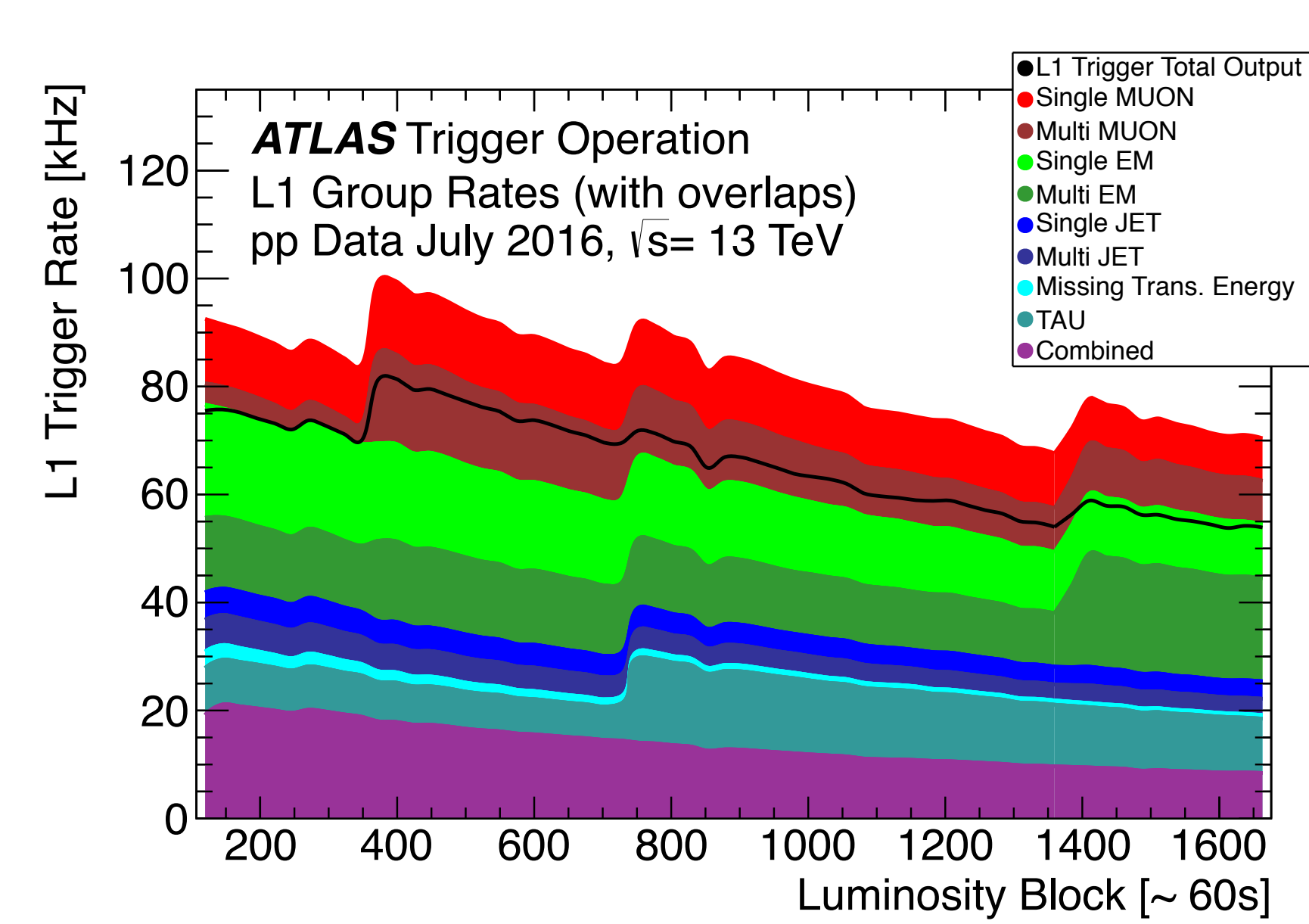

- **HLT menu** has ~2000 active chains
- Each chain can trigger either full Event Building [EB] or just partial sub-detector data to be recorded into different *Streams*
- Majority of chains record to *Main* stream with full EB
- *Express* stream is reconstructed first, providing calibration data
- *Delayed* stream is reconstructed with some delay, to ease demands on prompt reconstruction computing
- *Trigger Level Analysis*: high rate (3 kHz) of just the trigger data. Used in e.g. dijet resonance searches
- Chains, primary and support, are organized into physics groups
- For 2018, prescale sets are defined up to $L=2 \times 10^{34} \text{ cm}^{-2}\text{s}^{-1}$

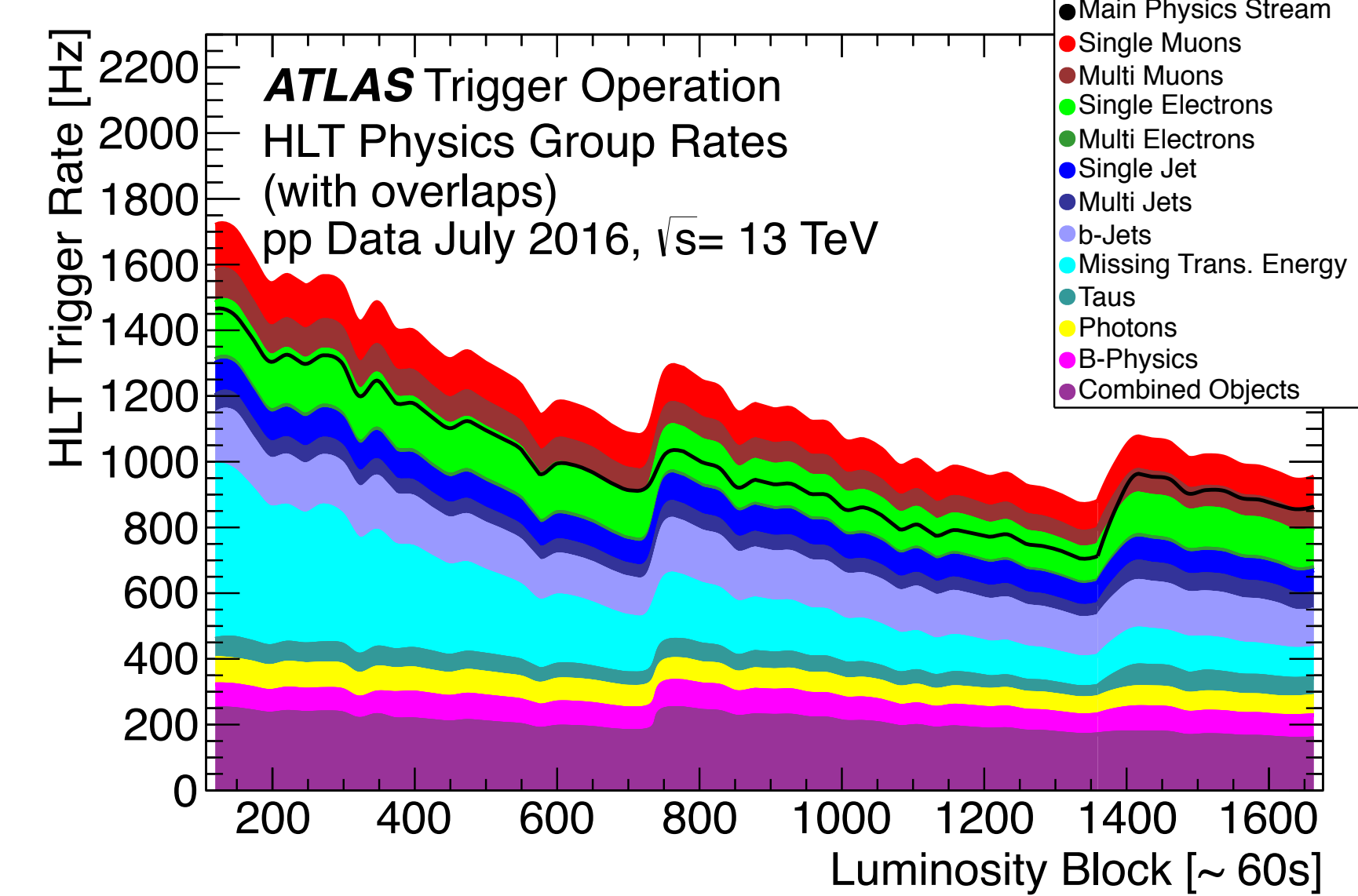
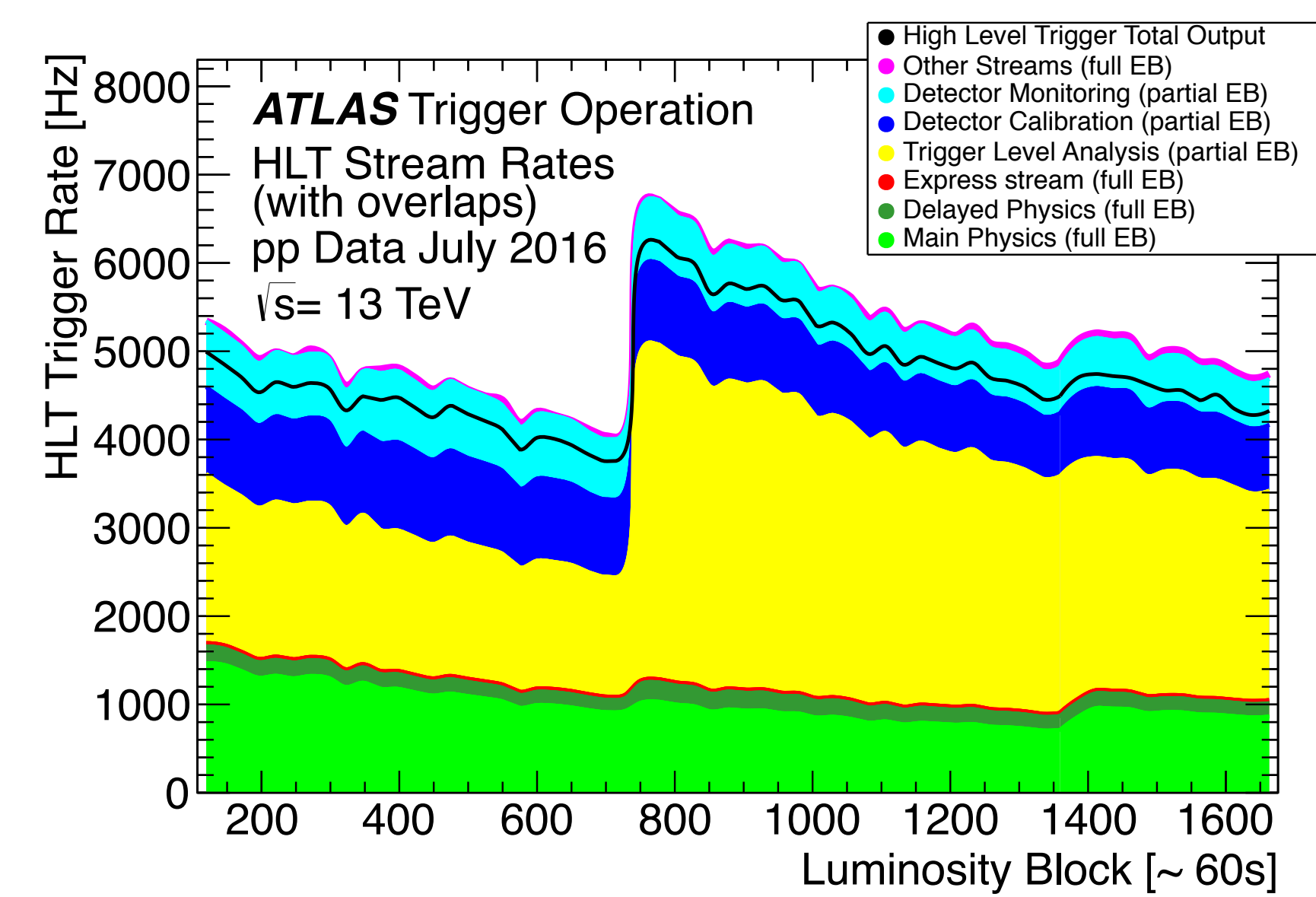

L1 Topological trigger

- **L1 Topo**: new system commissioned in 2016, exploits topological information in order to greatly reduce L1 rates with minimal impact on physics
- Can exploit angular distances, di-object mass, transverse mass, etc.
- Example: di-muon trigger with additional $\Delta R_{\mu\mu}$ and $m_{\mu\mu}$ cut achieves a factor 4 rate reduction with only ~10% loss in efficiency selecting B-hadron candidates

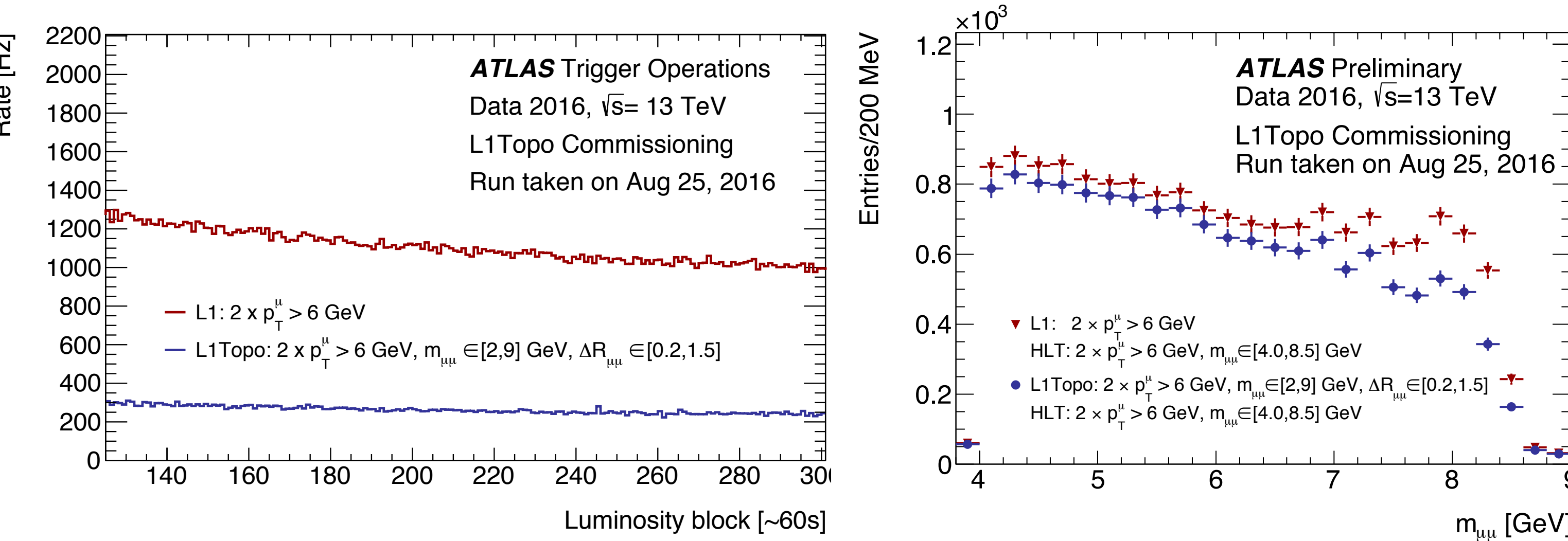

Trigger performance at high pileup

- The noise filters for Level-1 Calo were updated for an optimal performance at peak luminosity. This update reduced the rate of L1 $E_{T,miss}$ and low- p_T jet triggers, with minimal impact on the trigger turn-on
- Inefficiency at high pile-up in isolated muon triggers, was reduced with tighter $|z_0|$ selection on tracks used for isolation, at the cost of increased HLT rate

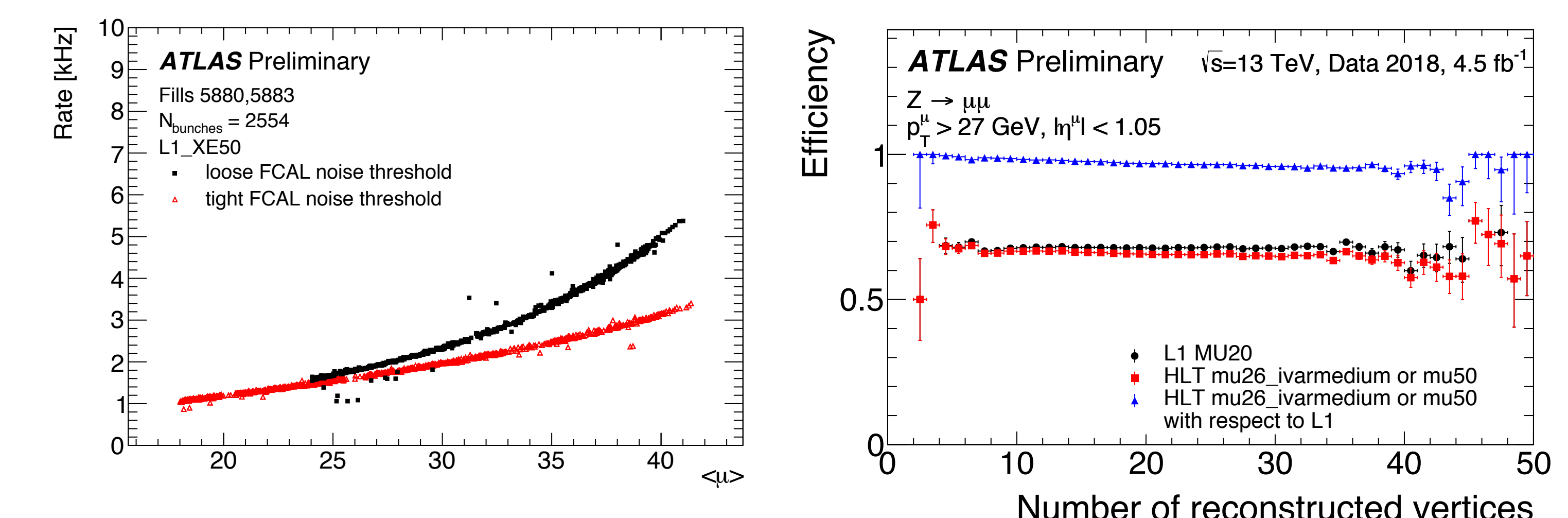

Trigger menu at high luminosity

- During the 2018 run ATLAS intends to maintain constant the p_T thresholds of the trigger menu deployed in 2017
- Several improvements were introduced, both at L1 and HLT, to allow the main physics chains to remain unprescaled up to higher luminosities
- New L1 Muon-Calorimeter (Tile) coincidence in muon system gap gives 10% rate reduction
- Decommissioning of non-L1Topo backup triggers
- Extensive use of alternative options such as delayed stream and end-of-fill triggers
- New default $E_{T,miss}$ algorithm (*pufit+cell*) combines two different reconstruction strategies. Reduced HLT rate with same $E_{T,miss}$ threshold
 - *pufit*: $E_{T,miss}$ reconstructed from hard-scatter clusters. Identify clusters as hard-scatter or pileup based on a threshold that depends on the total event energy
 - *cell*: $E_{T,miss}$ reconstructed from calorimeter cells above noise threshold

