



AIDA 2020

Advanced European Infrastructures
for Detectors at Accelerators

Ion microbeam facility at RBI as a tool for detector characterization



N. Skukan, **M. Jakšić**, I. Bogdanović-Radović, T. Tadić, **S. Fazinić**, Z. Siketić, I. Zamboni, I. Božičević Mihalić, **I. Sudić**, D. Španja, Ž. Periša, A. Kovačević
(**Veljko Grilj**)

Ruđer Bošković Institute, Bijenička c. 54, 10000 Zagreb, Croatia



This project has received funding from the European Union's Horizon 2020 research and innovation programme under grant agreement No 654168.



- 1. Facility
- 2. Statistics in brief
- 3. Ion Beam Induced Charge
- 4. Some AIDA runs



- **8 TA projects** have been already **approved**
- **7 TA access** have been **completed** by 30th March 2017
(on schedule –completed)
- Users from **6 countries supported**

RBI	User Projects		Total users	TA units
	Submissions	Selected		
M1-M22	8	8	<u>17 (11 supported)</u>	<u>280</u>
M1-M48	16		24	640



RBI	User-projects		Total no. of users benefitting from the TA	Units of access (RBI=beam operation hour)
	Eligible submissions	Selected		
Period 1 (M1-M18)	5	5	11 (8 received financial support)	200
Foreseen for project (M1-M48)	16		24 (with the financial support)	640

RBI	User-projects		Total no. of users benefitting from the TA	Units of access (RBI=beam operation hour)
	Eligible submissions	Selected		
Mid-term (foreseen*) (M1-M24)	8	8	19 (12 with the financial support)	320
Foreseen for project (M1-M48)	16		24 (with the financial support)	640

* i.e. assuming that recently approved project AIDA-2020-RBI-2017-1 will be implemented in April.



Periodic Report	Researcher			Employing organisation/Home institution			TA project acronym	Activity Domain (Discipline)
	Name	Gender	Nationality	Name	Legal status	Country		
2015								
P1	Jerzy Pietraszko	Male	Poland	GSI Helmholtzzentrum für Schwerionenforschung	RES	Germany	AIDA-2020-RBI-2015-1	Physics
P1	Michal Pomorski	Male	Poland	CEA - Commissariat à l'énergie atomique et aux énergies alternatives	RES	France	AIDA-2020-RBI-2015-2	Physics
P1	Jacques de Sanoit	Male	France	CEA-Commissariat à l'Energie Atomique et aux Energies Alternatives	RES	France	AIDA-2020-RBI-2015-2	Physics, Chemistry,
P1	Michael Kokkoris	Male	Greece	National Technical University of Athens	UNI	Greece	AIDA-2020-RBI-2015-3	Physics
P1	Srdjan Petrović	Male	Serbia	Vinča Institute of Nuclear Sciences	RES	Serbia	AIDA-2020-RBI-2015-3	Physics
P1	Iain Haughton	Male	UK	The University of Manchester	UNI	UK	AIDA-2020-RBI-2015-4	Physics
P1	Steven Murphy	Male	UK	The University of Manchester	UNI	UK	AIDA-2020-RBI-2015-4	Physics
2016								
P1	Claudio Verona	Male	Italy	University of Rome "Tor Vergata"	UNI	Italy	AIDA-2020-RBI-2016-1	Physics
P1	Gianluca Verona Rinati	Male	Italy	University of Rome "Tor Vergata"	UNI	Italy	AIDA-2020-RBI-2016-1	Physics
P1	Giulio Magrin	Male	Austria	EBG MedAustron	RES	Austria	AIDA-2020-RBI-2016-1	Physics
P1	Mandy Bandorf	Female	Austria	EBG MedAustron	RES	Austria	AIDA-2020-RBI-2016-1	Physics
P1	Giulio Magrin	Male	Italy	EBG MedAustron	Profit or not profit Pr	Austria	AIDA-2020-RBI-2016-2	Physics
P1	Alberto Fazzi	Male	Italy	Politecnico di Milano	UNI		AIDA-2020-RBI-2016-2	Physics
P1	Sofia Colombi	Female	Italy	Politecnico di Milano	UNI		AIDA-2020-RBI-2016-2	Physics
P1	Michael Kokkoris	Male	Greece	National Technical University of Athens	UNI		AIDA-2020-RBI-2016-3	Physics
P1	Konstantinos Preketes-Sig	Male	Greece	National Technical University of Athens	UNI		AIDA-2020-RBI-2016-3	Physics
P1	Srdjan Petrović	Male	Serbia	Vinča Institute of Nuclear Sciences	RES		AIDA-2020-RBI-2016-3	Physics



• PUBLICATIONS

➤ 4 Oral contributions to conferences :

Jerzy Pietraszko et al., "Radiation damage in scCVD diamond material measured with relativistic Au ions for future CBM/HADES experiments at FAIR" 4th ADAMAS Workshop at GSI, December 4, 2015, GSI Helmholtzzentrum für Schwerionenforschung,, Germany

➤ Jerzy Pietraszko et al., DPG Spring Meeting, Darmstadt, 14 - 18 March 2016 "Systematic study of radiation hardness of single crystal CVD diamond material investigated with an Au beam and IBIC method."

➤ Veljko Grilj et al., 15. ICNMTA 2016, 31. Jul-5. Aug 2016 "Radiation hardness study on multi-strip diamond sensor", invited

➤ Alex Oh "3D diamond detectors for particle tracking and dosimetry", invited talk, European Materials Research Society Symposium Materials for electronics and optoelectronic applications, Warsaw, Poland, 19-22 September 2016.

➤ 1 paper publication

M. Erich et al, EBS/C proton spectra from a virgin diamond crystal, NIMB 381 (2016)96-102.

➤ 3 papers in preparation

➤ + several posters



Laboratory for ion beam interactions

Accelerator facility

1.0 MV HVE Tandatron
accelerator



6.0 MV EN Tandem Van
de Graaff accelerator





AIDA 2020

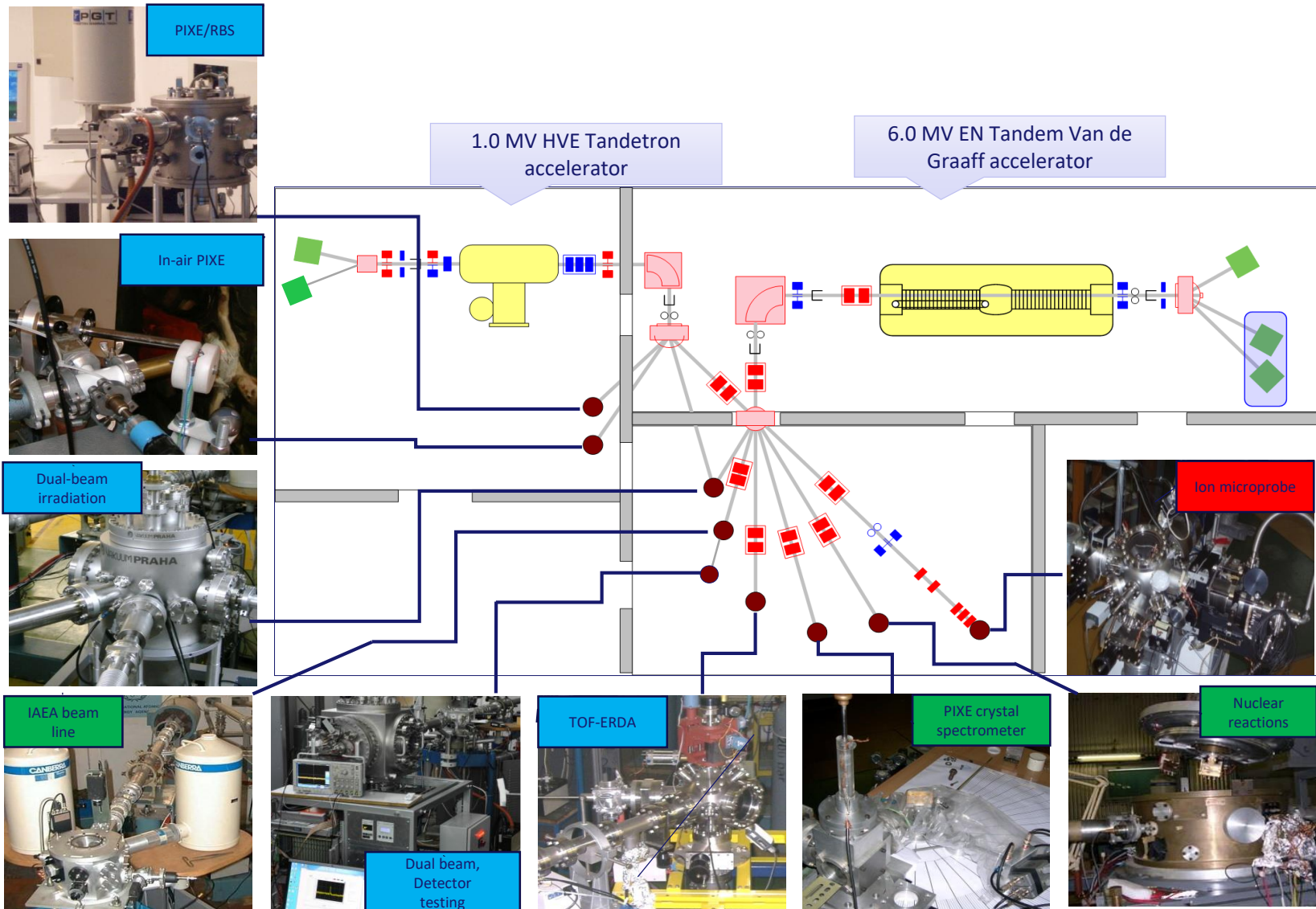



Ion Beam Induced Charge

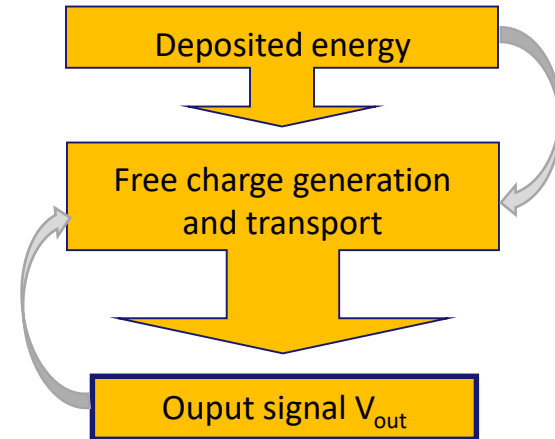
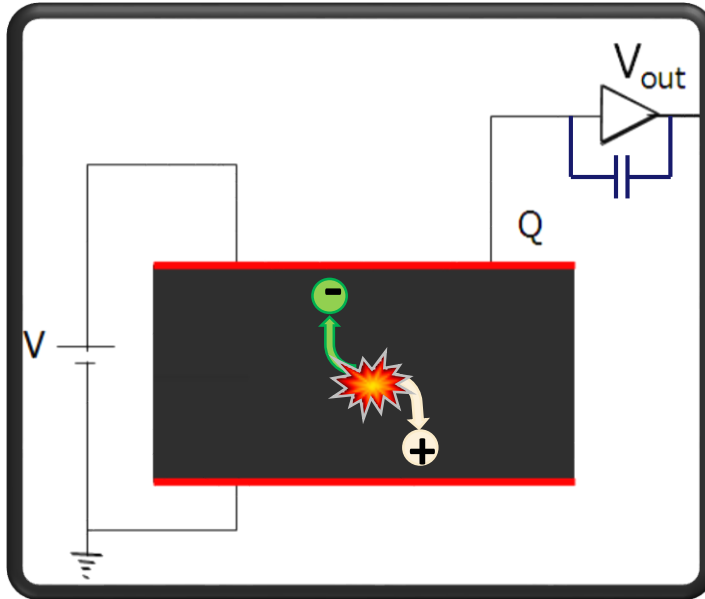

Gunn's Theorem:
$$i_i = -q\vec{v} \frac{\partial \vec{E}(\vec{r}(t))}{\partial V_i} \Big|_{V_j = \text{const.}}$$

$V_{\text{out}} = F$ (deposited energy, free carrier transport)



What is needed for IBIC?

③ IONS

- p, α , Li, C, O,...

④ RANGE

- 1 to 1000 μm

② POSITION

- Focusing and scanning

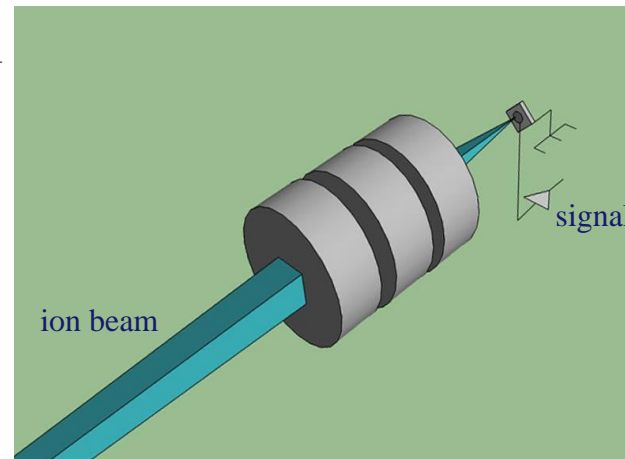
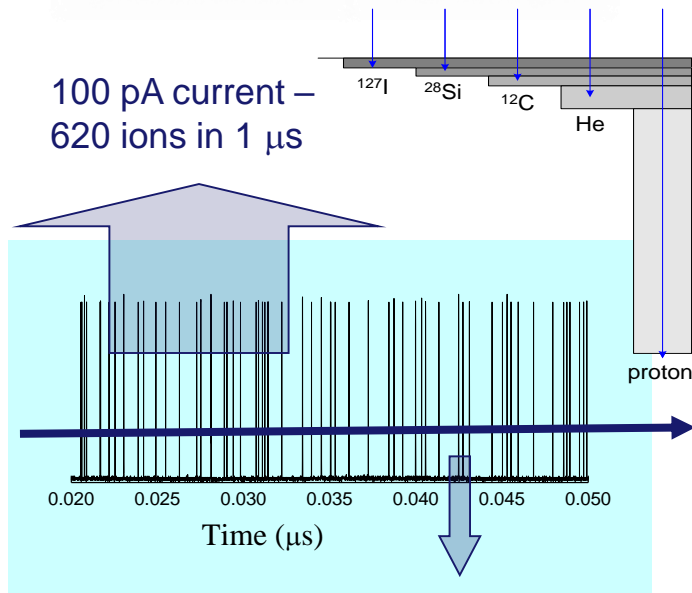

① RATE

- 0 - 10^6 p/s

0.1 fA current – 620 ions/second

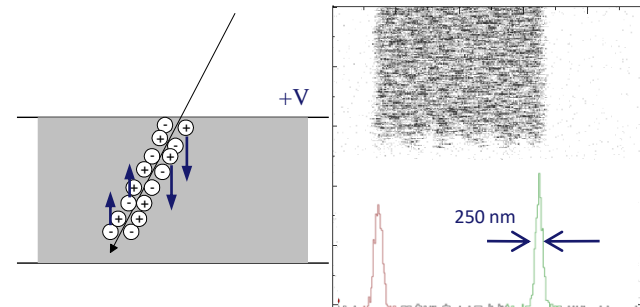



Nuclear microprobe

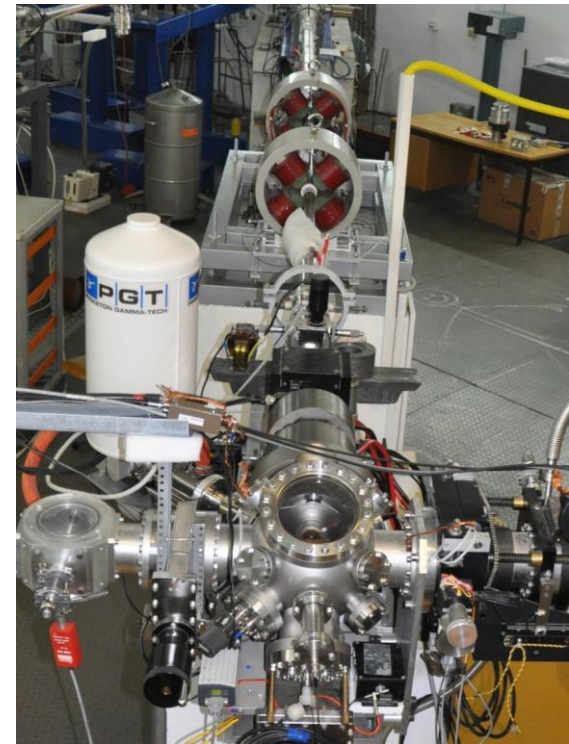
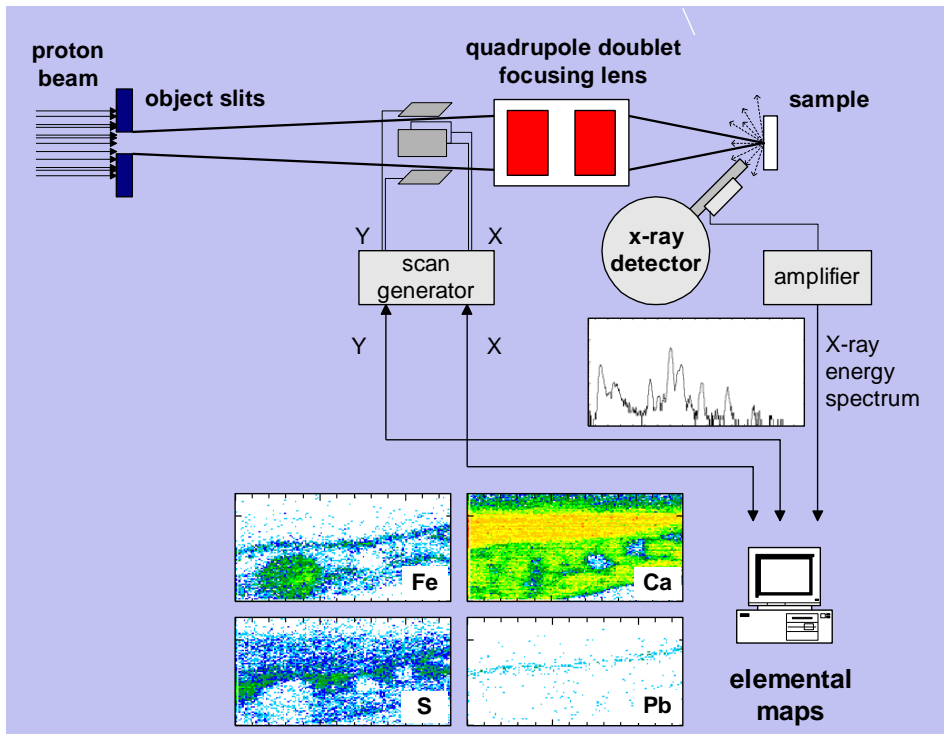



IBIC imaging

Configurations:

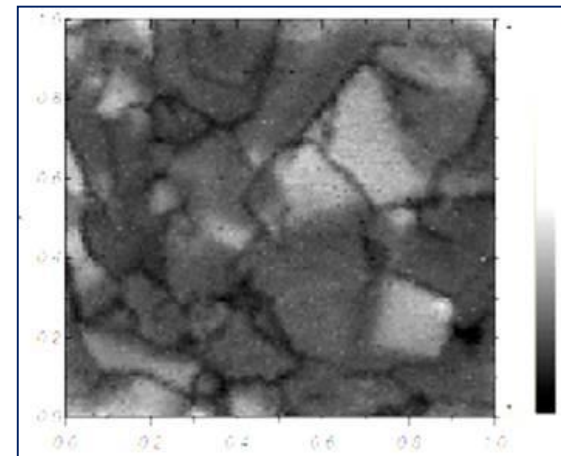
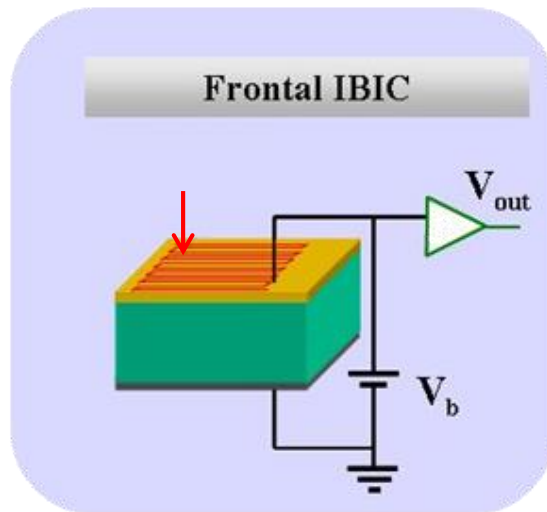



IBIC imaging

Configurations:

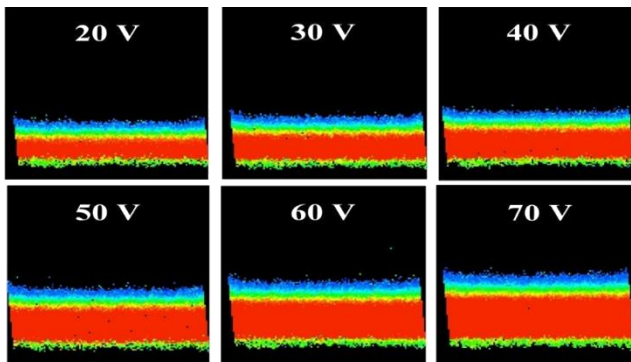

2 MeV p⁺

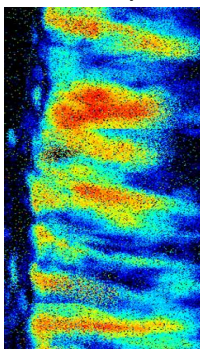

2 MeV He⁺

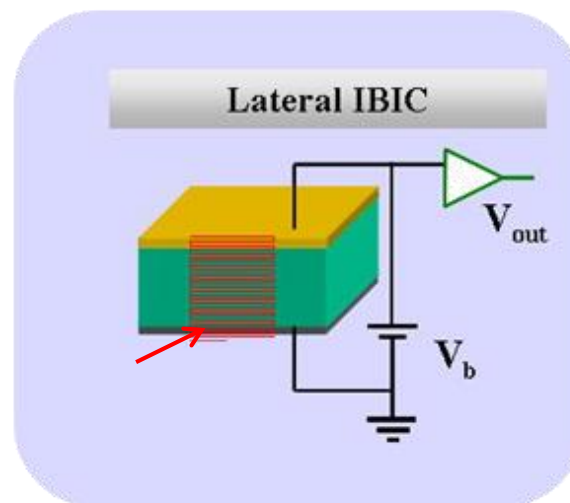
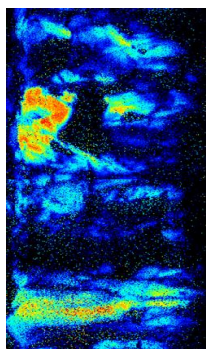



Examples – defects mapping

<http://www.unito.it/>

Lateral damage creation

- frontal IBIC defect mapping
- Bragg peak clearly visible

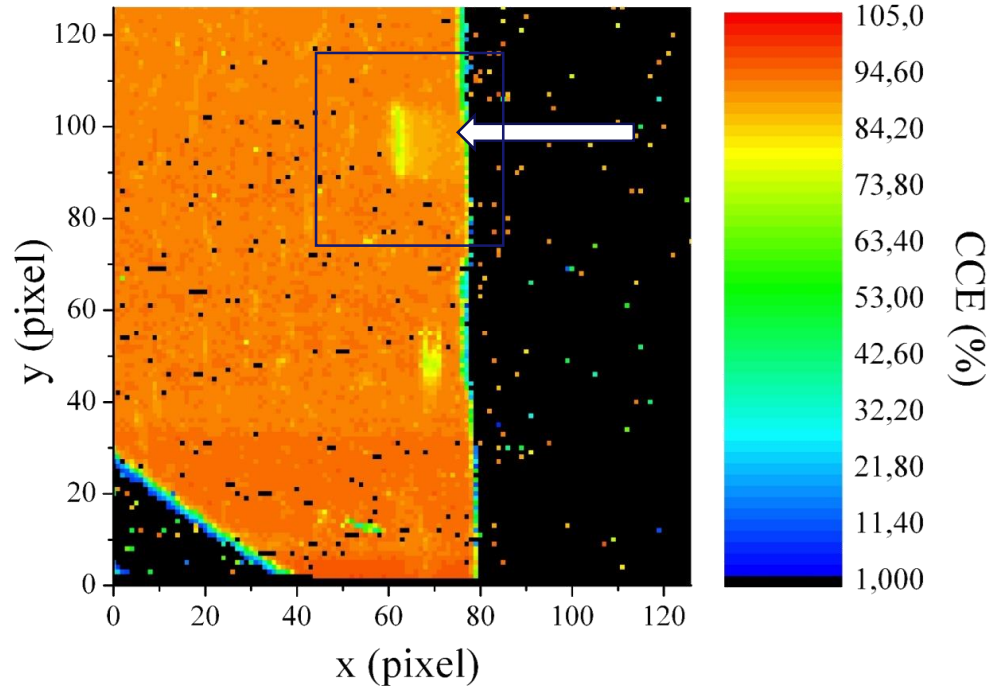



Examples – radiation hardness tests

An ion microprobe allows for:

➤ selective damage introduction

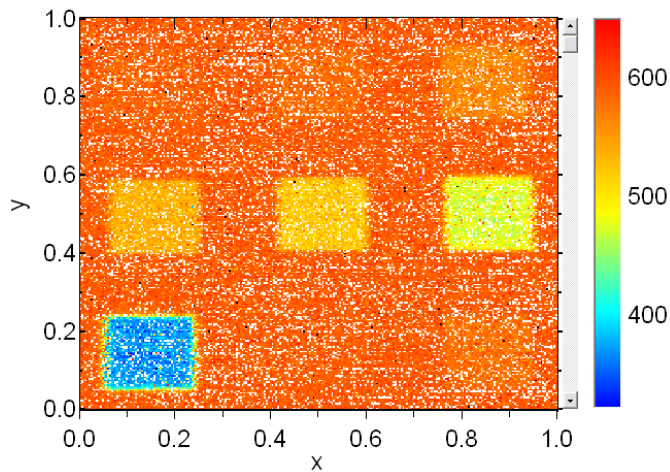

➤ on-line monitoring of CCE degradation and total fluence

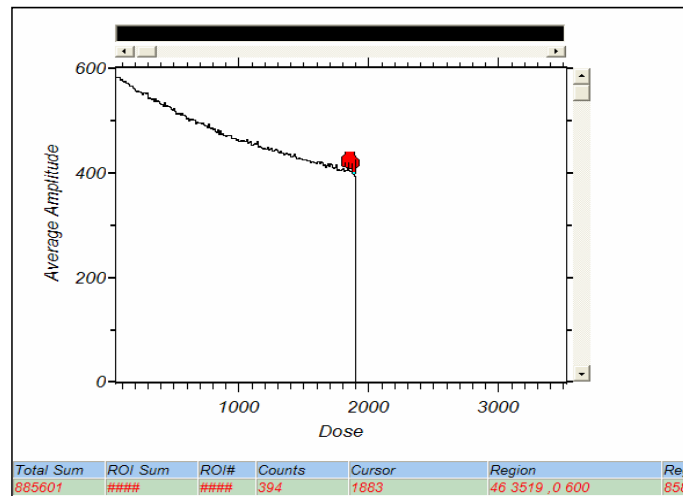



Charge transient spectroscopy (QTS) setup

(similar to DLTS)

- CoolFET preamplifier
+WaveMaster
8500A oscilloscope
- Target temperatures:
-100°C to +700°C
- Achieved:
-40°C to 600°C
- Stability $\pm 0.5^\circ\text{C}$

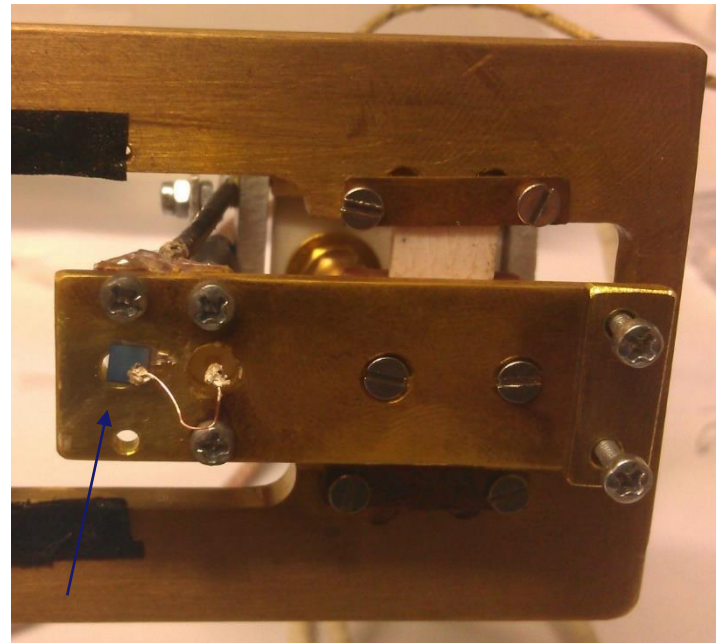

NDT sample mounted on QTS setup

QTS trace analysis- NDT HPHT sample

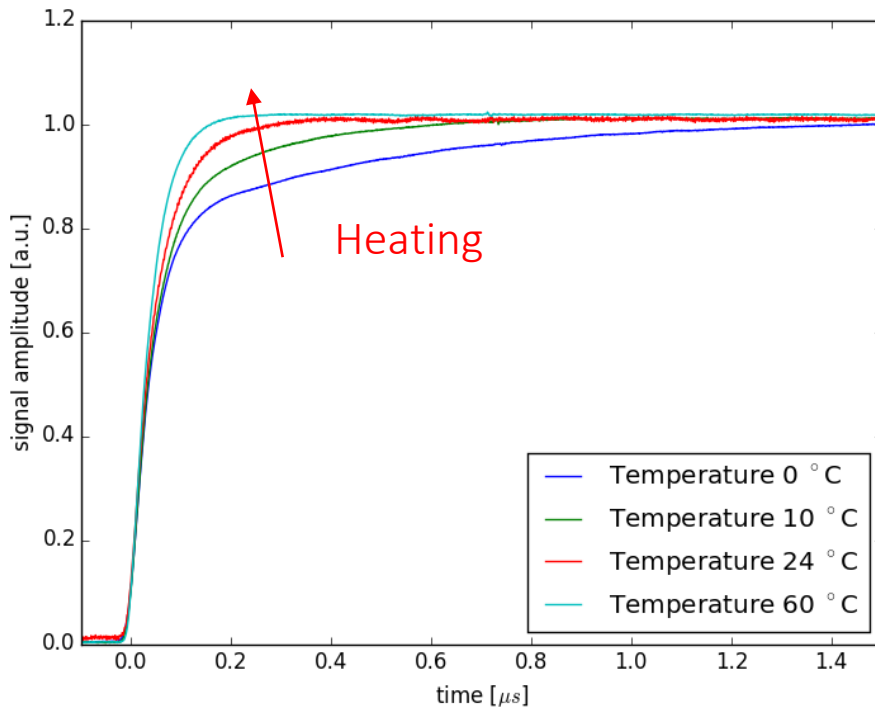

$$A = A_0(1 - e^{-e_1 t})$$

$$e_1 \sim \sigma N_D e^{-\frac{\Delta E}{kT}}$$

- Traps in whole sample:
 - $\Delta E = 0.53 \text{ eV} \pm 0.1 \text{ eV}$
 - σN_D is lower
 - Boron? Arsenic?

- Traps close to the edge:
 - $\Delta E = 0.43 \text{ eV} \pm 0.04 \text{ eV}$
 - σN_D is higher
 - Boron? Arsenic?



Time resolved IBIC (AKA mapped TCT)

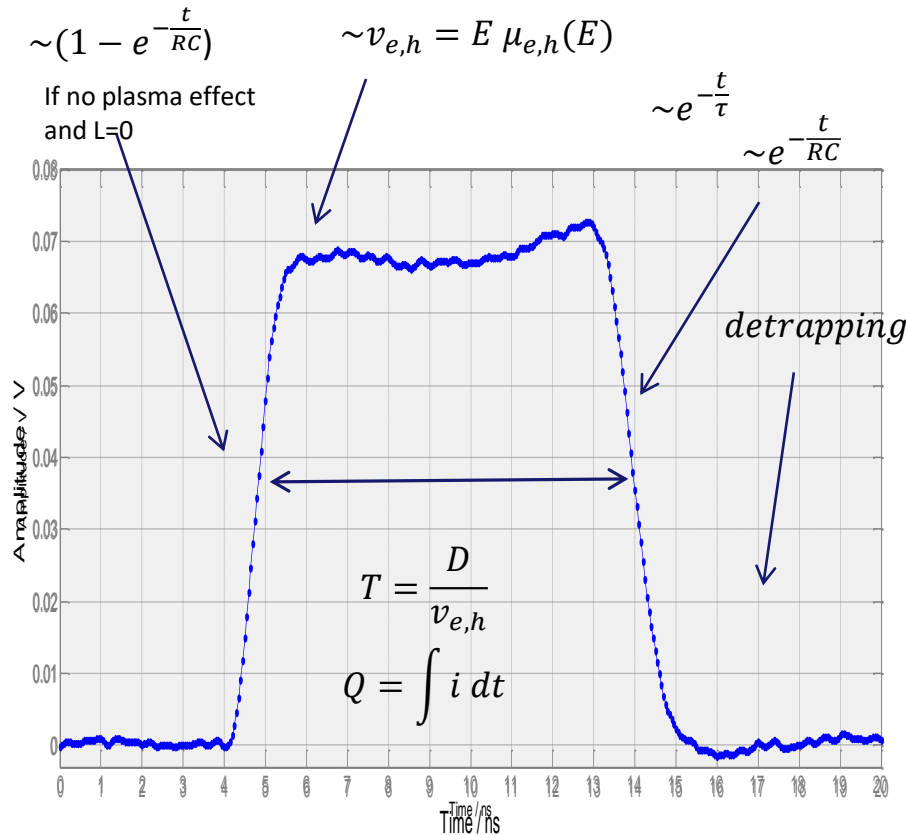

TCT gives different information about physical parameters of the sample depending on the beam and energy chosen

Coupled with beam scanning, possible to characterize the sample spatially

scCVD diamond
Ideal case

➤ AIDA-2020-RBI-2015-4

3D diamond, Alexander Oh, University of Manchester, UK

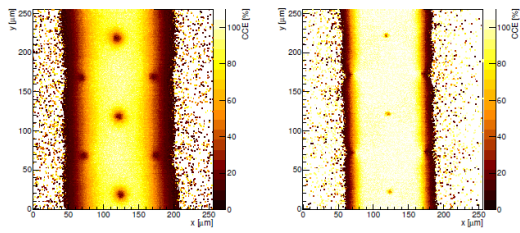
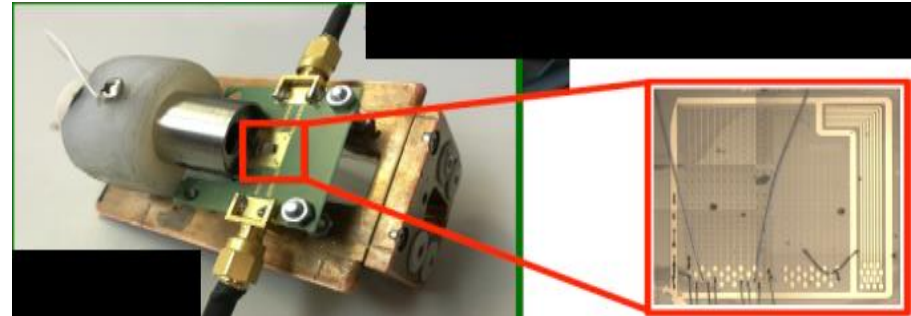
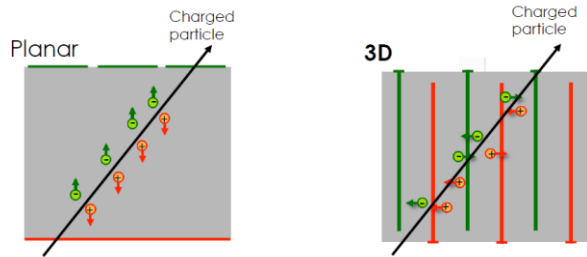

(a)

(b)

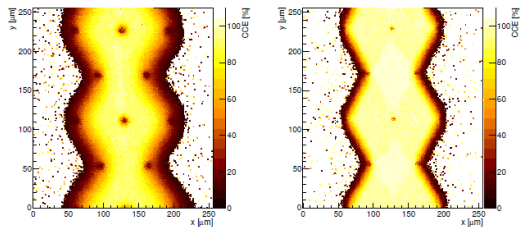

(c)

(d)

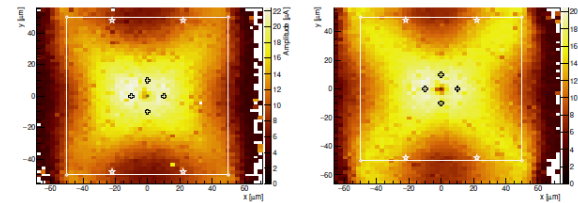

(a)

(b)

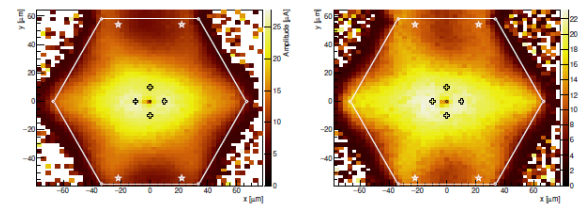

(c)

(d)

CCE maps for different biases and geometries

TRIBIC (TCT) amplitude maps



➤ AIDA-2020-RBI-2016-1

IBIC characterization of single crystal diamond based Shottky diodes for microdosimetry application, Claudio Verona, 'Tor Vergata' University, Italy

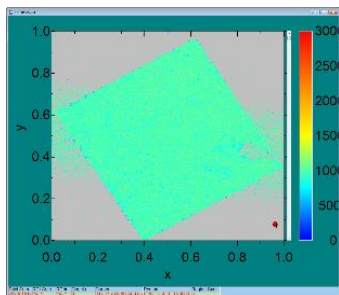
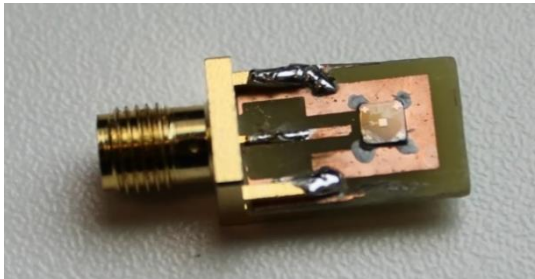

➤ AIDA-2020-RBI-2016-2

Microbeam tests of silicon telescope for clyncal dosimetry, G. Magrin, Austron, Austria

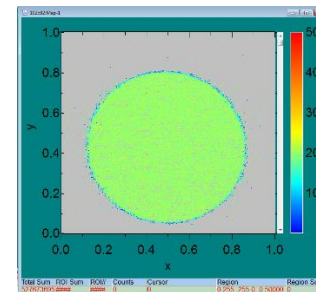



➤ AIDA-2020-RBI-2015-2

Diamond Membranes for Radioisotope Batteries BATDiam, Michal Pomorski, CEA, LIST, France

Generation of power by coupling a beta source to a semiconductor junction device

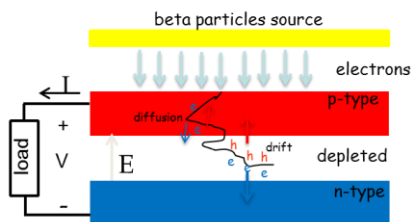

α instead of β
particles

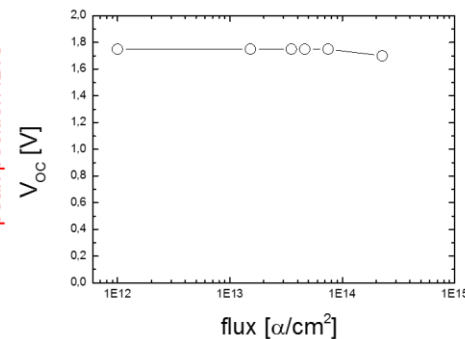
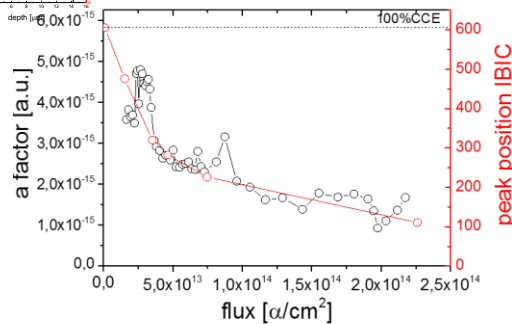
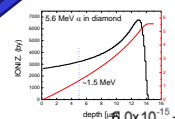
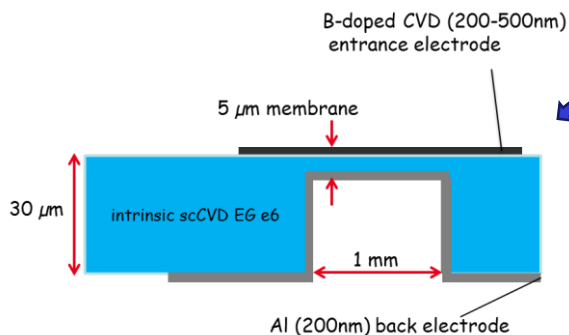
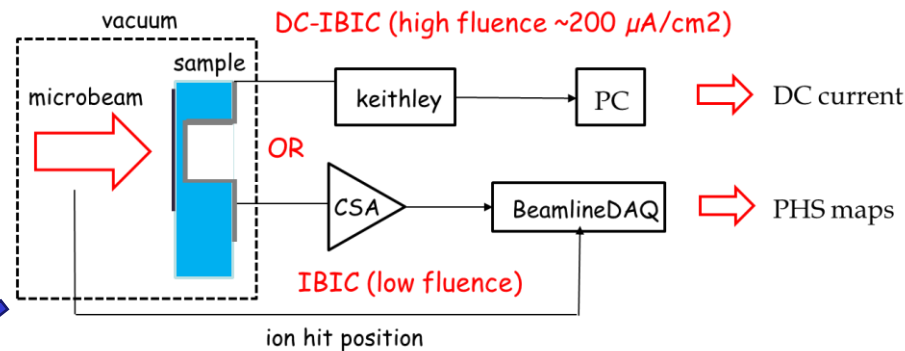



➤ AIDA-2020-RBI-2015-1

Systematic study of radiation damage in scCVD diamond material irradiated with relativistic Au beams, Jerzy Pietraszko, GSI Darmstadt, HADES, Germany

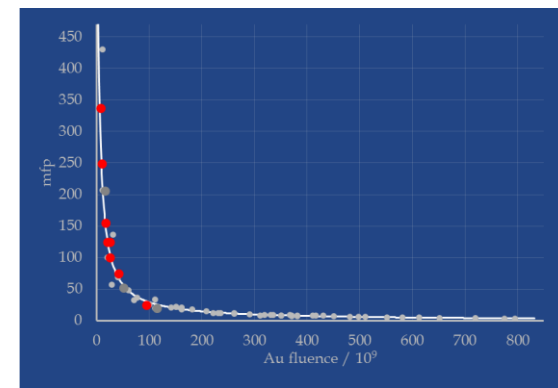
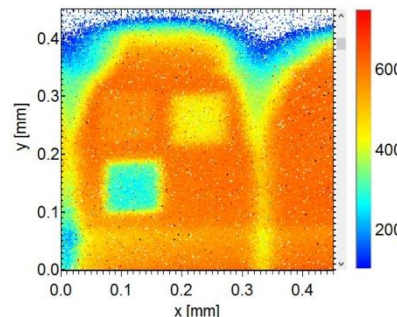
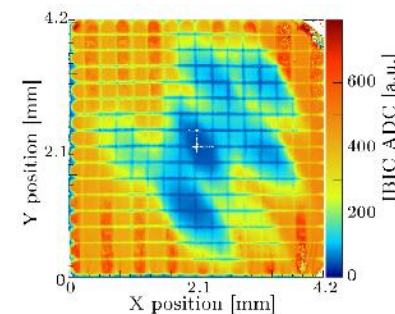
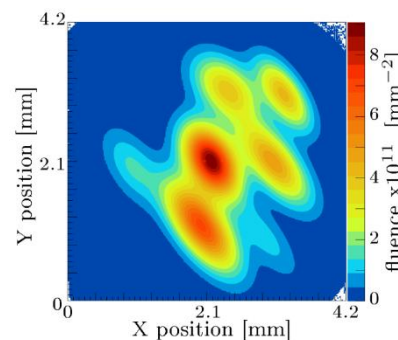
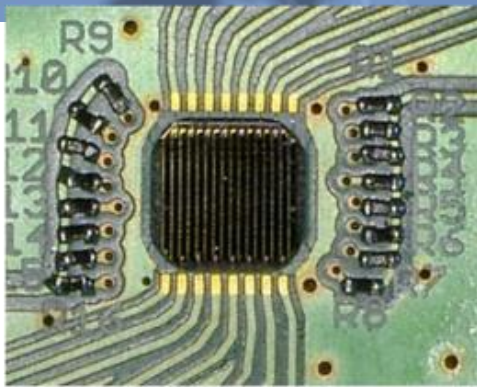
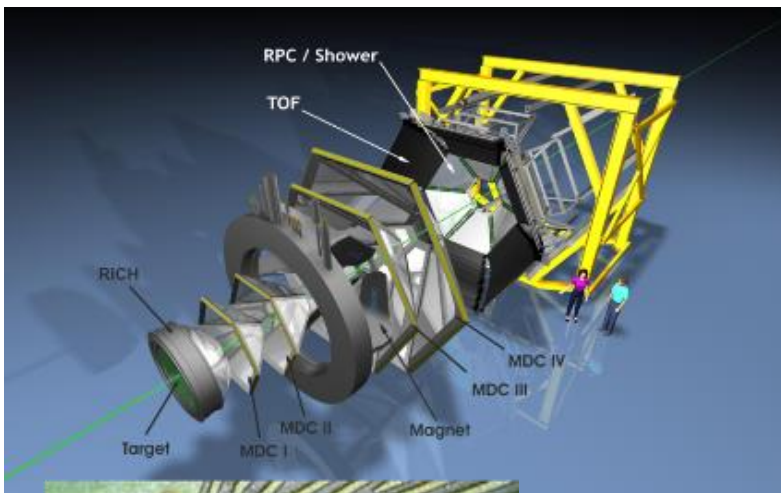

Number of traps:

$$\text{Au} / p_{4.5\text{MeV}} / p_{24\text{GeV}} = 1 / 30 / 2430$$

$$p_{4.5\text{MeV}} / p_{24\text{GeV}} = 81$$

Correlating fluences from different sources and detector degradation scCVD diamond strip detector

To conclude:

- RBI accelerator facility hosts microbeam line used for IBIC and semiconductor modification among other uses
- Ion Beam Induced Charge/Current is efficient method for mapping basic properties of semiconductor and insulator detector materials
- Several different setups of IBIC exist: Lateral, Frontal, TRIBIC (TCT), Temperature dependent...
- So far 7 (+1 in the following month) different characterizations carried out through AIDA transnational access program



AIDA²⁰²⁰

Thank you for attention!

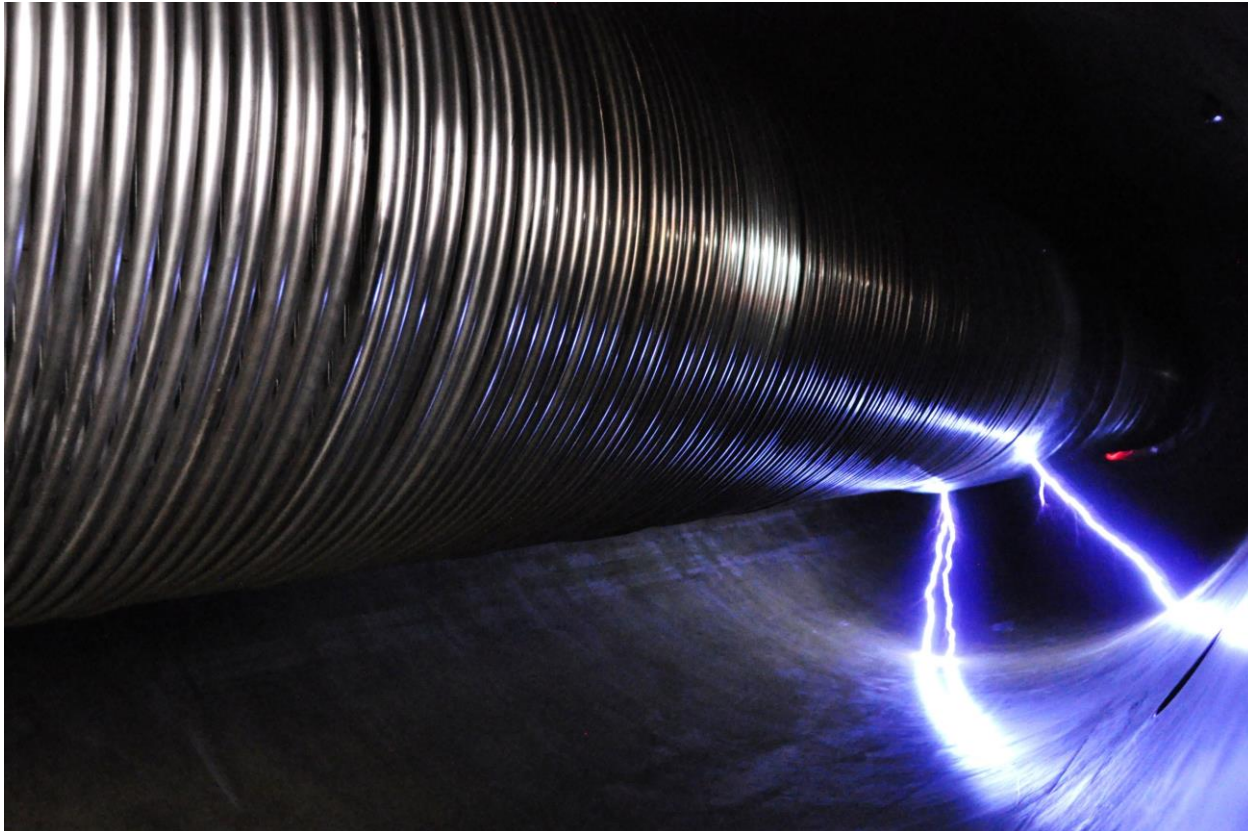



- **TA completed:**

- **AIDA-2020-RBI-2015-1**

Systematic study of radiation damage in scCVD diamond material irradiated with relativistic Au beams, Jerzy Pietraszko, GSI Darmstadt, HADES, **Germany**.

- **AIDA-2020-RBI-2015-2**

Diamond Membranes for Radioisotope Batteries BATDiam, Michal Pomorski, CEA, LIST, **France**

- **AIDA-2020-RBI-2015-3**

Investigation of channeling depth profiles of high energy carbon and silicon ions implanted in diamond and SiC crystals for detector characterization, Michael Kokkoris, National Technical University of Athens, **Greece**

- **AIDA-2020-RBI-2015-4**

3D diamond, Alexander Oh, University of Manchester, **UK**

- **AIDA-2020-RBI-2016-1**

IBIC characterization of single crystal diamond based Shottky diodes for microdosimetry application, Claudio Verona, 'Tor Vergata' University, **Italy**

- **AIDA-2020-RBI-2016-2**

Microbeam tests of silicon telescope for clinical dosimetry, G. Magrin, Austron, **Austria**

- **AIDA-2020-RBI-2016-3**

Investigation of channeling depth profiles of high energy carbon and silicon ions implanted in SiC /Si crystals for detector characterization, University of Athens, **Greece**



- **The last TA proposal submitted and approved in March 2017:**

- **AIDA-2020-RBI-2017-1**

Diamond Membrane Microdosimeter, Michal Pomorski, CEA, LIST, **France**

expected two users; one or both supported by the project

Realization expected before the end of April (although there is high possibility to delay the experiment due to some problems in the sample preparation as reported recently by the PI).



AIDA

2020



AIDA 2020

Advanced European Infrastructures for
Detectors at Accelerators

[Home](#) [Project](#) [Activities](#) [Transnational Access](#) [Events](#) [Results](#) [AIDA](#) [Contact](#)

Transnational Access

AIDA-2020 Transnational Access supports small teams to carry out experiments and tests at one of the 10 European facilities listed below:

Type of facility	Access provider	Infrastructure	Country	Facility Coordinator Contact
Beam test	CERN	PS&SPS	International Organisation	Henric Wilkens ✉
	DESY	DESY-II	Germany	Marcel Stanitzki ✉
Irradiation test	CERN	IRRAD	International Organisation	Michael Moll ✉
	CERN	GIF++	International Organisation	Michael Moll ✉
	JSI	TRIGA Reactor	Slovenia	Vladimir Cindro ✉
	KIT	KAZ	Germany	Alexander Dierlamm ✉
	UCLouvain	CRC	Belgium	Eduardo Cortina Gil ✉
	UoB	MC40 Cyclotron	UK	David Parker ✉
Detector characterisation	RBI	RBI-AF	Croatia	Stjepko Fazinić ✉
	ITAINNOVA	EMClab	Spain	Fernando Arteché ✉



Ion beam analysis

